

OPERATING INSTRUCTIONS ^{CE}

Multi jet vane wheel water meters: wet type (WM) and dry type (WS-CE).
DN15÷50*



Congratulations on choosing our product. Below we present the operating instruction of multi jet vane wheel water meters, introduced for usage/sale by Apator Powogaz S.A. in Poznań, according to the procedures of an Integrated system of quality, environment and safety management. Please, read the instruction thoroughly before installing the device in order to ensure usage according to its intended use.

1. The subject of the instruction

This instruction defines the criteria of correct choice, the conditions of correct installation, operation and maintenance as well as the rules regarding safety, environment protection and disposal of water meters designed for measurement of volume of potable water used for business and industrial purposes which flows in closed circuits (pipelines).

Table 1 – Types of water meters and their intended uses

type	use
WS – dry type (DN15÷50) WM – wet type (DN15÷40)	<ul style="list-style-type: none"> • Cold water min. 0.1°C - max 50°C • Operating pressure max 1.6Mpa (16bar)
WS-NK; WS-NKP; (DN15÷50) WM-NK; WM-NKP; (DN15÷40)	<ul style="list-style-type: none"> • Cold water min. 0.1°C - max 50°C • Operating pressure max 1.6Mpa (16bar) • NK – reed switch transmitter • NKP – a counter adapted to a reed switch transmitter (a standard design for WS)

Table 2 – Installation positions

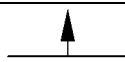
Water meter type	Installation orientation			Counter location
	Horizontal	Vertical	Diagonal	
WS-NKP	✘	-	-	 counter face up
WM	✘	-	-	 counter face up

Sample WS and WM water meter marking:

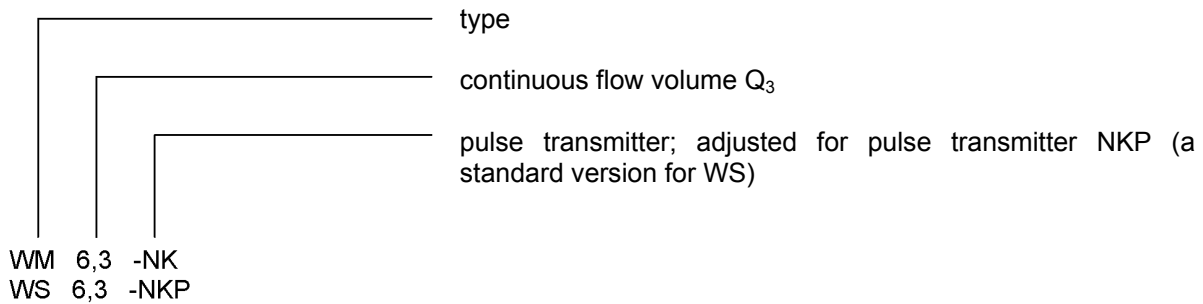

Table 3 – Values of constant flow volume Q_3

Water meter type	WS-NKP	WM	Parameter
Size	Q_3		Length – Thread
[mm]	[dm ³]		[mm] – [“]
15	2.5		165 i 190 – G ³ / ₄ “
20	2.5		165 and 190 – G1”
20	4		190 – G1”
25	6.3		260 – G1 ¹ / ₄ “
32	10		260 – G1 ¹ / ₂ “
40	16		300 – G2“
50*	25	-	300 – G2 ¹ / ₂ “

2. Technical data – standards and regulations

Technical data is included in the specification sheets for each type of water meter.

Water meters comply with the following standards and regulations:

1. MID directive 2004/22/EC of 31.03.2004 on measuring instruments.
2. PN-EN-14154 standards harmonised with a directive 2004/22/EC of the European parliament and the European council of 31 march 2004. MID (Measuring Instruments Directive)
3. PN-ISO 4064 – Measurement of water flow in conduits. Water meters for cold potable water.
4. Ordinance of the Minister of Economy of 18.12.2006 on basic requirements for measurement instruments, as amended.
5. Ordinance of the Minister of Economy of 07.01.2008 on legally required metrologic control of measurement instruments.
6. Ordinance of the Minister of Economy of 21.12.2007 on requirements to be fulfilled by heat meters and their components for detailed range of tests performed during legal metrologic inspection of the measurement instruments.
7. Ordinance of the Minister of Economy of 13.02.2004 on metrologic requirements regarding water heat meters and their components.

Manufactured water meters may have other installation lengths than the ones provided in PN-ISO-14154 standard. It is so because of specific user needs.

The basic requirements regarding the installation of water meters can be found in standards:

PN-B-10720 – Water supply systems Installation of water meter sets in water supply systems.

Requirements and testing upon receipt.

PN-EN-14154 – 2: Installation and operating conditions.

3. Description of proper water meter operation

Multi jet dry type water meter

Multi jet water meter rotor is propelled by a couple of (multiple) water jets evenly pushing the rotor vanes along the wheel perimeter and it is the only moving part which is submerged in water. Rotor rotation is conveyed by a magnetic head clutch, through the sealing plate. Dry counter, sealed air-tight in a separate module, sums the flow of measured water and displays the result in a digital, easy to read manner. Counter is fitted with a motion detector which makes it possible to automate

regulation and legalisation. The regulating device is protected from tampering by a lead seal. Thanks to a special design of rotor bearings and the choice of corrosion and abrasion resistant materials, the water meter is characterised by high durability.

Multi jet wet type water meter

Multi jet water meter rotor is propelled by a couple of (multiple) water jets evenly pushing the rotor vanes along the wheel perimeter. The parts submerged in water are: rotor and a counting mechanism with rolls or, for a version with separate rolls space, are submerged in glycerine. Rotor rotation is transmitted via a gear transmission through a hole in the lower plate of a counting mechanism. Counter module sums up the flow of measured water and displays the result in a digital, easy to read manner. Counter is fitted with a motion detector which makes it possible to automate regulation and legalisation. The regulating device is protected from tampering by a lead seal. Thanks to a special design of rotor bearings and the choice of corrosion and abrasion resistant materials, the water meter is characterised by high durability.

4. Choosing the right water meter size

The main criterion for choosing the right water meter size (nominal diameter) should always be the water meter working conditions, that is the average and maximum value of a passing water working flow.

When a water meter is too large, it does not only increase the investment cost, but also has lower accuracy in cases of small water flow.

A too small water meter can cause its overload, and simultaneously quicken the wear of its active parts.

In order to ensure that the water meter works within its measurement range and the acceptable accuracy error ranges, you have to specify the scope of its work during the day, or define this scope based on the monthly water consumption, taking into account current, minimum and maximum values of jet flow.

It is recommended to choose the size of the water meter so that the size of the largest expected jet flow in the system is between 0.45 and 0.6 of the water meter constant jet flow Q_3 .

Values of constant jet flow for a given type of water meter were provided in table 3.

5. Testing at the receipt

The water meter supplied by the manufacturer should be checked for possible external damage which occurred during transport, especially the body, threaded connectors and the counter cover, as well as the electrical cable (in the design with the transmitter).

Also, check the condition of lead seals for legalising info, securing features and quality of fastening, as well as the labelling of a water meter.

The following markings are located on the counter disc, plaque or a body of the water meter:

- name and marking of a manufacturer,
- mark of test type according to MID,
- manufacturer's mark of type,
- water meter number,
- metrologic marking consists of an upper-case M and two last digits of *the water meter year of production* when the marking was placed on the measurement instrument,
- flow direction, as an arrow,
- H marking for water meters for horizontal pipes,
- jet flow value Q_3 per m^3/h ,
- marking of measurement unit in m^3 (on the counter dial),
- value of the maximum pressure loss Δp ,
- value of the upper pressure limit: PN 16,

6. Conditions of correct installation of a water meter

6.1. Place of installation for water meters should be easily accessible for installation, deinstallation and operation, reading indications, separated from utility and industrial rooms. Protected from negative atmospheric conditions and protected from the influence of electrical and gas installations. In case there is no such place, the water meter may be installed in the water meter well, and additionally the water meter and its equipment should be installed far enough from the well bottom. The well should be fitted with a settling pond or a water outlet.

6.2. In the location of installation, the water meter cannot be at risk of being hit or be subjected to vibrations caused by other devices in the vicinity, or subjected to high ambient air temperature, contamination, flooding

and corrosive action of the surroundings. Temperature in the installation location should not be lower than 4°C. The water meter should be protected from influence of such hydraulic phenomena such as cavitation or hydrodynamic water hammering.

6.3. Before, and after the water meter, provide the valves in order to cut off the water supply if there is need for deinstallation or repair. Use valves which can entirely reveal the cross-section of a water pipe.

6.4. In case of expected water contamination during the time of operation install a filter or a settling tank between a valve and a straight pipe section and before the water meter.

6.5. For an installation of a water meter which does not cause strain in the body it is recommended to use compensative connectors installed at the output, which enable for the length reduction by extending the telescopic connector sleeve.

6.6. The pipe in the installation location should be shaped so that there is no possibility for an air pocket to be created in the water meter. Water meter has to be entirely filled with water, so the water pipe after the water meter cannot decline (Fig. 1).

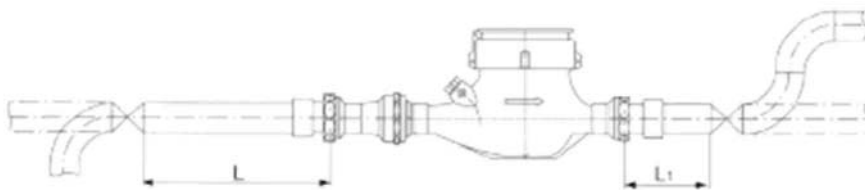

Fig.1

6.7. Water meter should not be under risk of excessive strain caused by pipelines and equipment. If necessary, install it on a pedestal or in a grip. What is more, the pipes connecting on the inlet and outlet side should be adequately fastened, so that no part of the system is dislocated by the water when the water meter is deinstalled or disconnected from one side.

6.8. During installing a meter in the water network, observe the correct water meter orientation according to the design: horizontal (Table 2).

6.9. When using typical connectors, using other straight sections before (U0) and after (D0) the device is not required.

However, in case of installing devices after a double elbow, non-return valve or a pump, provide a straight pipe section $L=5 \times DN$ (device nominal diameter) before the device (U5), and after the device $L1=3 \times DN$ (D3) (Fig.1).

6.10. Pipe sections before and after the water meter should be coaxial. Gaskets should be placed concentrically in relation to the pipe. Eccentric installation of a water meter in a pipe is not permitted, in particular the dislocation of gaskets between the water meter and the pipe so that they cover a part of the free pipe cross-section at the water meter and interrupt the flow. In order for the connector ends to be introduced in the right threaded connector projection, the pipeline should be able to spring back about 3 mm.

6.11. Water flow through the water meter should correspond to the direction of arrows placed on both sides of the body.

WARNING!!! When the water meter is connected, performing welding works is not allowed, as it will cause it to be damaged.

7. Filling with water and start-up of a water meter.

7.1. Before installing the water meter, the pipeline should be flushed in order to remove contamination, and the filter (if it is used) should be cleaned. During flushing, use a spigot to replace the water meter.

7.2. Before installation, check the operation of a water meter by starting a rotating motion of a rotor while observing the rotation or the rotation of the counter indicators. Check the lead seal condition.

7.3. Before installing the water meter, water should be supplied freely to the pipeline, with the vents open so that the air that leaves the system does not cause excessive water meter rotations, which causes the device damage.

7.4. During operation, the valves before and after the water meter should be entirely open.

7.5. After performing all the actions related to the start-up, check the water meter operation by observing the increase of the counter indication.

7.6. During operation, check whether the actual operating conditions correspond to the water meter intended use, in particular in terms of permitted pressure, temperature and flow.

8. Maintenance, inspections and repairs

Water meter is an instrument which measurement capacity changes over time. Moreover, the deterioration of this capacity is generally a result of aggressive water influence or jamming the rotor by solid dirt. That is why, in case of irregularities in operation, every water meter should be deinstalled and, without damaging the lead seals, the dirt should be removed by rinsing the measurement unit with a water jet with medium strength. If this fails, give the water meter to a servicing point.

In the servicing point it is recommended to thoroughly check its indication accuracy for the purpose of comparison, and only after this is done, start the disassembly and cleaning. Do not use cleaning chemicals which have harmful influence on the materials from which the water meter elements are made of. It is unacceptable to use for cleaning any chemical reagents which cause corrosion of materials or which are solutions, particularly for plastics, or which cause accelerated ageing of gaskets.

Repairs should be performed in specially prepared water meter repair stations, or in service plants.

When the repair necessitates replacement of parts, use only original spare parts supplied by Apator Powogaz S.A. After the repair, the water meters are checked according to the current regulations. Expiry dates of the compliance assessments (legalisation periods) are specified in the metrologic regulations.

9. Storage and transport

Water meters received from deliveries or deinstalled from the mains should be stored with counter face up or on the side, in a closed room free from caustic, stinking vapours etc. which have a destructive effect on the water meter condition. The room temperature should be between 5 and 30°C, and air relative humidity no more than 80%. Both during transport and storage, the devices should be protected from vibrations and in particular from shock which may cause damage of body or internal elements. The transport should take place with covered means of transport in manufacturer's packaging or a substitutive package which entirely protects the product from damage.

10. Malfunctions and removing them

If the counter does not indicate anything as the water flows, check whether the rotor is not jammed by dirt. If the water meter does not work after cleaning and in any other case it is not working, give it to be repaired. Remember to share your observations. If the pulse transmitter is not working, notify the supplier. If after the consultation with the supplier the fault cannot be removed, the water meter should be left at a service.

11. Safety requirements and environmental aspects

11.1. The water meter is a measurement device which is safe to use if installation and operation requirements adequate for the intended use are observed.

11.2. During installation, handling and operation there may be threats relating to the water meter itself:

Mechanical threats:

- if carried improperly, it may fall.
- water leaks and flooding due to installation of the product which does not agree with installation requirements or excessive water pressure;

11.3. To counteract the mechanical threats, the devices have handy grips which enable them to be conveniently grabbed.

11.4. In order to install and use the device, choose a well lit, easily accessible place with a hardened floor

surface which prevents fall.

11.5 Water meter components do not contain substances harmful for health and the environment. All cold water meters are hygienically approved for potable water contact.

11.6 Counter seals and other design solutions to protect the water meter from negative influence of steam condensation on correct reading of indication or transmitter operation.

11.7 Classification of environmental requirements

- Classification of mechanical environmental requirements – class M1 – acc. to Ordinance of the Minister of Economy as of 18.12.2006.
- Classification of climatic and mechanical environmental requirements – class B – acc. to PN-EN-14154-3:2005+A1
- Classification of environmental electromagnetic requirements – class E1 – acc. to Ordinance of the Minister of Economy as of 18.12.2006.

12 Value of water meter pulse and a connection diagram

12.1 The value of water meter pulse in basic design (standard) for a contact transmitter

Table 4

Size [mm]	Water meter type		Pulse value [dm ³]
	WS-NKP	WM	
15	Q3 [dm ³ /h]		1
20	2.5		10
20	4		10
25	6.3		10
32	10		10
40	16		100
50	25	-	100

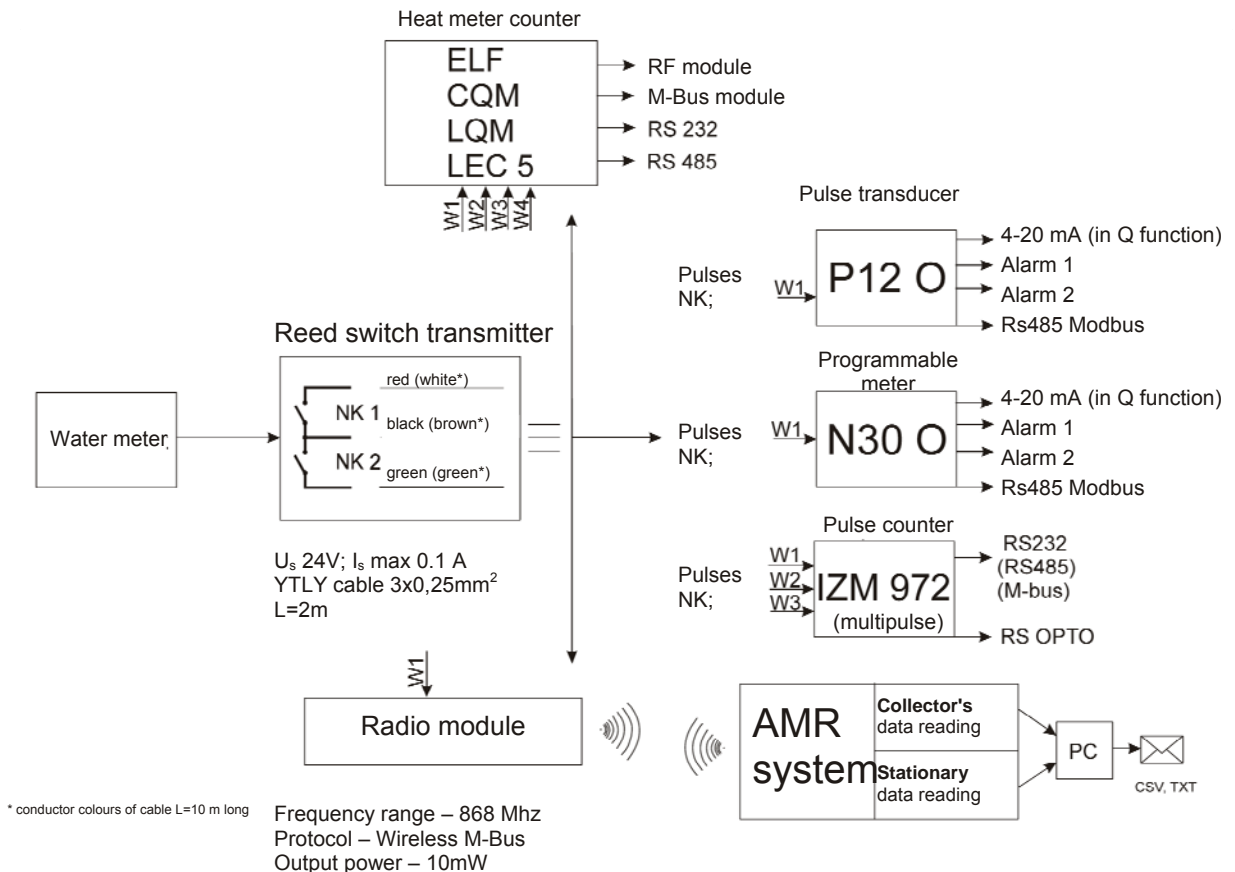

Fig. 2

Example connection scheme for remote transfer of readings

12.2. Other pulse values than in the basic design (standard) may be ordered as well for the reed switch transmitter, data available according to specification sheets. In case of such order, pulse values will be according to the client requirements specified in the order.

12.3. Extension of transmitter cable

In order to extend the standard transmitter cable, use a cable with a single conductor diameter of at least 0.75 mm² taking into account the recommendation, that the total impedance of the extended section should not be higher than 500 Ohm. See to it that the extended cable does not cross with the existing layout of power supply or automatic control cables

Warning: Use possibly the shortest extensions.

13. What to do with used product packages

The package is made of recyclable corrugated board. You can dispose of it in every waste paper purchase point. Additional information regarding the re-cycling of particular materials which the water meters are built of as well as proper disposal methods can be obtained in relevant company departments.

14. User's evaluation

The operating instructions are constantly updated. You can help us optimize the operating instruction to better suit the users' needs by sending us your suggestions. Please, send all the remarks regarding the operating instruction as well as the use of water meters to the manufacturer's address.

WARNING!!!

Within the range of technological progress, the manufacturer reserves the right to introduce changes to the manufactured products without marking them in the operating instruction. We send a spare parts catalogue upon the client's request.



ul. Klemensa Janickiego 23/25
60-542 Poznań, tel. 061 8418100
<http://www.powogaz.com.pl>
Sales Department:
tel. 061 8418148, fax 061 8472548
e-mail: handel@powogaz.com.pl