

**Nidec**  
All for dreams

## *Control User Guide*

---

# ***Digitax HD M750***

---

Variable Speed AC drive for  
Servo and Induction motors

Part Number: 0478-0530-01  
Issue: 1

## Original Instructions

For the purposes of compliance with the EU Machinery Directive 2006/42/EC, the English version of this manual is the Original Instructions. Manuals in other languages are Translations of the Original Instructions.

### Documentation

Manuals are available to download from the following locations: <http://www.drive-setup.com/ctdownloads>

The information contained in this manual is believed to be correct at the time of printing and does not form part of any contract. The manufacturer reserves the right to change the specification of the product and its performance, and the contents of the manual, without notice.

### Warranty and Liability

In no event and under no circumstances shall the manufacturer be liable for damages and failures due to misuse, abuse, improper installation, or abnormal conditions of temperature, dust, or corrosion, or failures due to operation outside the published ratings. The manufacturer is not liable for consequential and incidental damages. Contact the supplier of the dive for full details of the warranty terms.

### Environmental policy

Control Techniques Ltd operates an Environmental Management System (EMS) that conforms to the International Standard ISO 14001.

Further information on our Environmental Policy can be found at: <http://www.drive-setup.com/environment>

### Restriction of Hazardous Substances (RoHS)

The products covered by this manual comply with European and International regulations on the Restriction of Hazardous Substances including EU directive 2011/65/EU and the Chinese Administrative Measures for Restriction of Hazardous Substances in Electrical and Electronic Products.

### Disposal and Recycling (WEEE)



When electronic products reach the end of their useful life, they must not be disposed of along with domestic waste but should be recycled by a specialist recycler of electronic equipment. Control Techniques products are designed to be easily dismantled into their major component parts for efficient recycling. The majority of materials used in the product are suitable for recycling.

Product packaging is of good quality and can be re-used. Large products are packed in wooden crates. Smaller products are packaged in strong cardboard cartons which have a high recycled fibre content. Cartons can be re-used and recycled. Polythene, used in protective film and bags for wrapping the product, can be recycled. When preparing to recycle or dispose of any product or packaging, please observe local legislation and best practice.

### REACH legislation

EC Regulation 1907/2006 on the Registration, Evaluation, Authorisation and restriction of Chemicals (REACH) requires the supplier of an article to inform the recipient if it contains more than a specified proportion of any substance which is considered by the European Chemicals Agency (ECHA) to be a Substance of Very High Concern (SVHC) and is therefore listed by them as a candidate for compulsory authorisation.

Further information on our compliance with REACH can be found at: <http://www.drive-setup.com/reach>

### Registered Office

#### Nidec Control Techniques Ltd

The Gro

Newtown

Powys

SY16 3BE

UK

Registered in England and Wales. Company Reg. No. 01236886.

### Copyright

The contents of this publication are believed to be correct at the time of printing. In the interests of a commitment to a policy of continuous development and improvement, the manufacturer reserves the right to change the specification of the product or its performance, or the contents of the guide, without notice.

All rights reserved. No parts of this guide may be reproduced or transmitted in any form or by any means, electrical or mechanical including photocopying, recording or by an information storage or retrieval system, without permission in writing from the publisher.

Copyright © December 2018 Nidec Control Techniques Ltd

# How to use this guide

This guide is intended to be used in conjunction with the *Digitax HD M75X Series Installation and Technical Guide*. The *Installation and Technical Guide* gives information necessary to install the drive. This guide gives information on drive configuration, operation and optimization.

## NOTE

There are specific safety warnings throughout this guide, located in the relevant sections. In addition, Chapter 1 *Safety information* contains general safety information. It is essential that the warnings are observed and the information considered when working with or designing a system using the drive.

This map of the user guide helps to find the right sections for the task you wish to complete, but for specific information, refer to *Contents* on page 4:

	Quick Start / bench testing	Familiarisation	System design	Programming and commissioning	Troubleshooting
1 Safety information	●	●	●	●	●
2 Product information		●	●		
3 Mechanical Installation			●		
4 Electrical installation			●		
5 Getting started		●	●		
6 Basic parameters		●	●	●	
7 Running the motor	●	●	●	●	
8 Optimization			●	●	
9 Drive communication			●	●	
10 SD Card operation			●	●	
11 Onboard PLC			●	●	
12 Advanced parameters			●	●	
13 Diagnostics					●
14 UL listing information			●	●	

---

# Contents

---

<b>1</b>	<b>Safety information</b> .....	<b>8</b>	<b>6</b>	<b>Basic parameters</b> .....	<b>41</b>
1.1	Warnings, Cautions and Notes .....	8	6.1	Parameter ranges and variable minimum / maximums .....	41
1.2	Important safety information. Hazards. Competence of designers and installers .....	8	6.2	Menu 0: Basic parameters .....	41
1.3	Responsibility .....	8	6.3	Parameter descriptions .....	46
1.4	Compliance with regulations .....	8	6.4	Full descriptions .....	48
1.5	Electrical hazards .....	8	<b>7</b>	<b>Running the motor</b> .....	<b>57</b>
1.6	Stored electrical charge .....	8	7.1	Quick start connections .....	57
1.7	Mechanical hazards .....	8	7.2	Changing the operating mode .....	57
1.8	Access to equipment .....	8	7.3	Quick start commissioning / start-up .....	59
1.9	Environmental limits .....	8	7.4	Quick start commissioning / start-up using Connect .....	66
1.10	Hazardous environments .....	8	7.5	Setting up a feedback device .....	68
1.11	Motor .....	9	7.6	Encoder Simulation Output Set-up .....	73
1.12	Mechanical brake control .....	9	<b>8</b>	<b>Optimization</b> .....	<b>76</b>
1.13	Adjusting parameters .....	9	8.1	Motor map parameters .....	76
1.14	Electromagnetic compatibility (EMC) .....	9	8.2	Current limits .....	91
<b>2</b>	<b>Product information</b> .....	<b>10</b>	8.3	Motor thermal protection .....	91
2.1	Introduction .....	10	8.4	Switching frequency .....	91
2.2	Model number .....	10	8.5	High speed operation .....	92
2.3	Operating modes .....	11	<b>9</b>	<b>Drive communication</b> .....	<b>94</b>
2.4	Compatible position feedback devices .....	12	9.1	Ethernet communication .....	94
2.5	Nameplate description .....	12	9.2	CT Modbus TCP/IP specification .....	95
2.6	Options .....	13	9.3	RTMoE (Real Time Motion over Ethernet) .....	98
<b>3</b>	<b>Mechanical installation</b> .....	<b>15</b>	9.4	EtherNet/IP specification .....	100
3.1	SI-Option module installation .....	15	9.5	Profinet IO specification .....	113
3.2	KI-Compact Display installation .....	17	<b>10</b>	<b>SD Card Operation</b> .....	<b>117</b>
3.3	KI-Remote Keypad Adaptor installation .....	18	10.1	Introduction .....	117
<b>4</b>	<b>Electrical installation</b> .....	<b>19</b>	10.2	SD Card support .....	117
4.1	External 24 Vdc supply .....	19	10.3	Transferring data .....	118
4.2	Low voltage operation .....	20	10.4	Data block header information .....	119
4.3	Communication connections .....	21	10.5	NV Media / SD Card parameters .....	119
4.4	Control connections .....	21	10.6	SD Card trips .....	120
4.5	Position feedback connections .....	23	<b>11</b>	<b>Onboard PLC</b> .....	<b>121</b>
4.6	Safe Torque Off (STO) .....	29	11.1	Onboard PLC and Machine Control Studio .....	121
<b>5</b>	<b>Getting started</b> .....	<b>31</b>	11.2	Benefits .....	121
5.1	Display and Keypad operation .....	31	11.3	Features .....	121
5.2	KI-Remote Keypad operation .....	33	11.4	Onboard PLC parameters .....	121
5.3	Menu structure .....	35	11.5	Onboard PLC trips .....	122
5.4	Menu 0 .....	36			
5.5	Advanced menus .....	36			
5.6	KI-Remote Keypad changing the operating mode .....	38			
5.7	KI-Remote Keypad saving parameters .....	38			
5.8	Restoring parameter defaults .....	38			
5.9	Parameter access level and security .....	38			
5.10	Displaying parameters with non-default values only .....	39			
5.11	Displaying destination parameters only .....	39			
5.12	Communications .....	39			

<b>12</b>	<b>Advanced parameters .....</b>	<b>123</b>	<b>14</b>	<b>UL listing information .....</b>	<b>252</b>
12.1	Parameter ranges and Variable minimum/ maximums .....	126	14.1	Scope .....	252
12.2	Menu 1: Frequency / speed reference .....	136	14.2	Applicant and Listee .....	252
12.3	Menu 2: Ramps .....	140	14.3	Manufacturer .....	252
12.4	Menu 3: Frequency slaving, speed feedback and speed control .....	143	14.4	Model numbers .....	252
12.5	Menu 4: Torque and current control .....	154	14.5	Safety information .....	252
12.6	Menu 5: Motor control .....	158	14.6	Adjustments .....	252
12.7	Menu 6: Sequencer and clock .....	165	14.7	Ratings .....	252
12.8	Menu 7: Analog I/O / Temperature Monitoring ..	169	14.8	Short circuit current rating .....	252
12.9	Menu 8: Digital I/O .....	172	14.9	Overvoltage category .....	252
12.10	Menu 9: Programmable logic, motorized pot, binary sum and timers .....	176	14.10	Input current, fuse ratings and cable sizes .....	252
12.11	Menu 10: Status and trips .....	182	14.11	Motor cable size and maximum length .....	252
12.12	Menu 11: General drive set-up .....	184	14.12	Multiple wiring arrangements .....	252
12.13	Menu 12: Threshold detectors, variable selectors and brake control function .....	186	14.13	External 24 V supply .....	252
12.14	Menu 13: Standard motion controller .....	196	14.14	Common DC bus systems .....	252
12.15	Menu 14: User PID controller .....	200	14.15	Solid state short circuit protection .....	253
12.16	Menus 15, 16 and 17: Option module set-up .....	204	14.16	Motor overload protection .....	253
12.17	Menu 17: Ethernet Interface - Set-up .....	205	14.17	Motor overload protection and thermal memory retention .....	253
12.18	Menu 18: Application menu 1 .....	205	14.18	Enclosure rating .....	253
12.19	Menu 19: Application menu 2 .....	205	14.19	Mounting .....	253
12.20	Menu 20: Application menu 3 .....	205	14.20	Operating temperature .....	253
12.21	Menu 21: Second motor parameters .....	206	14.21	Pollution degree .....	253
12.22	Menu 22: Additional Menu 0 set-up .....	207	14.22	Plenum rating .....	253
12.23	Slot 3 Menu 0: Ethernet set-up .....	208			
12.24	Slot 3 Menu 2: Ethernet configuration .....	209			
12.25	Slot 3 Menu 9: Resources .....	209			
12.26	Slot 3 Menu 10: Easy Mode .....	210			
12.27	Slot 3 Menu 11: Synchronization .....	212			
12.28	Slot 3 Menu 15: Modbus .....	212			
12.29	Slot 3 Menu 20: EtherNet/IP .....	213			
12.30	Slot 3 Menu 21: EtherNet/IP In Mappings .....	214			
12.31	Slot 3 Menu 22: EtherNet/IP Out Mappings .....	215			
12.32	Slot 3 Menu 23: EtherNet/IP Fault Values .....	216			
12.33	Slot 3 Menu 24: Profinet Set-up .....	216			
<b>13</b>	<b>Diagnostics .....</b>	<b>217</b>			
13.1	Status modes (KI-Compact Display, KI-Remote Keypad and drive LED status) .....	217			
13.2	Trip indications .....	218			
13.3	Identifying a trip / trip source .....	218			
13.4	Trips, Sub-trip numbers .....	220			
13.5	Internal / Hardware trips .....	249			
13.6	Alarm indications .....	250			
13.7	Status indications .....	250			
13.8	Programming error indications .....	250			
13.9	Displaying the trip history .....	251			
13.10	Behaviour of the drive when tripped .....	251			

# EU Declaration of Conformity

**Nidec Control Techniques Ltd, The Gro, Newtown, Powys, SY16 3BE, UK.**

This declaration is issued under the sole responsibility of the manufacturer. The object of the declaration is in conformity with the relevant European Union harmonization legislation. The declaration applies to the variable speed drive products shown below:

Model number	Interpretation	Nomenclature aaaa - bbc ddddde
aaaa	Basic series	M100, M101, M200, M201, M300, M400, M600, M700, M701, M702, M708, M709, M750, M751, M753, M754, F300, H300, E200, E300, HS30, HS70, HS71, HS72, M000, RECT
bb	Frame size	01, 02, 03, 04, 05, 06, 07, 08, 09, 10, 11
c	Voltage rating	1 = 100 V, 2 = 200 V, 4 = 400 V, 5 = 575 V, 6 = 690 V
dddd	Current rating	Example 01000 = 100 A
e	Drive format	A = 6P Rectifier + Inverter (internal choke), D = Inverter, E = 6P Rectifier + Inverter (external choke), T = 12P Rectifier + Inverter (external choke)

The model number may be followed by additional characters that do not affect the ratings.

The variable speed drive products listed above have been designed and manufactured in accordance with the following European harmonized standards:

EN 61800-5-1:2007	Adjustable speed electrical power drive systems - Part 5-1: Safety requirements - Electrical, thermal and energy
EN 61800-3: 2004+A1:2012	Adjustable speed electrical power drive systems - Part 3: EMC requirements and specific test methods
EN 61000-6-2:2005	Electromagnetic compatibility (EMC) - Part 6-2: Generic standards - Immunity for industrial environments
EN 61000-6-4: 2007+ A1:2011	Electromagnetic compatibility (EMC) - Part 6-4: Generic standards - Emission standard for industrial environments
EN 61000-3-2:2014	Electromagnetic compatibility (EMC) - Part 3-2: Limits for harmonic current emissions (equipment input current ≤ 16 A per phase)
EN 61000-3-3:2013	Electromagnetic compatibility (EMC) - Part 3-3: Limitation of voltage changes, voltage fluctuations and flicker in public, low voltage supply systems, for equipment with rated current ≤ 16 A per phase and not subject to conditional connection

EN 61000-3-2:2014 Applicable where input current < 16 A. No limits apply for professional equipment where input power ≥ 1 kW.

These products comply with the Restriction of Hazardous Substances Directive (2011/65/EU), the Low Voltage Directive (2014/35/EU) and the Electromagnetic Compatibility Directive (2014/30/EU).



**Jonathan Holman-White**  
**Director of Research and Development**  
**Date: 13th August 2018**

**These electronic drive products are intended to be used with appropriate motors, controllers, electrical protection components and other equipment to form complete end products or systems. Compliance with safety and EMC regulations depends upon installing and configuring drives correctly, including using the specified input filters.**

**The drives must be installed only by professional installers who are familiar with requirements for safety and EMC. Refer to the Product Documentation. An EMC data sheet is available giving detailed information. The assembler is responsible for ensuring that the end product or system complies with all the relevant laws in the country where it is to be used.**

# EU Declaration of Conformity (including 2006 Machinery Directive)

**Nidec Control Techniques Ltd, The Gro, Newtown, Powys. UK. SY16 3BE**

This declaration is issued under the sole responsibility of the manufacturer. The object of the declaration is in conformity with the relevant Union harmonization legislation. The declaration applies to the variable speed drive products shown below:

Model No.	Interpretation	Nomenclature aaaa - bbc ddddde
aaaa	Basic series	M600, M700, M701, M702, M708, M709, M750, M751, M753, M754, F300, H300, E200, E300, HS70, HS71, HS72, M000, RECT
bb	Frame size	01, 02, 03, 04, 05, 06, 07, 08, 09, 10, 11
c	Voltage rating	1 = 100 V, 2 = 200 V, 4 = 400 V, 5 = 575 V, 6 = 690 V
dddd	Current rating	Example 01000 = 100 A
e	Drive format	A = 6P Rectifier + Inverter (internal choke), D = Inverter, E = 6P Rectifier + Inverter (external choke), T = 12P Rectifier + Inverter (external choke)

The model number may be followed by additional characters that do not affect the ratings.

**This declaration relates to these products when used as a safety component of a machine. Only the Safe Torque Off function may be used for a safety function of a machine. None of the other functions of the drive may be used to carry out a safety function.**

These products fulfil all the relevant provisions of the Machinery Directive 2006/42/EC and the Electromagnetic Compatibility Directive (2014/30/EU). EC type examination has been carried out by the following notified body:

TUV Rheinland Industrie Service GmbH  
Am Grauen Stein  
D-51105 Köln  
Germany

Notified body identification number: 0035  
The harmonized standards used are shown below:  
EC type-examination certificate numbers:  
01/205/5270.02/17 dated 2017-08-28

EN 61800-5-2:2016	Adjustable speed electrical power drive systems - Part 5-2: Safety requirements - Functional
EN 61800-5-1:2016 (in extracts)	Adjustable speed electrical power drive systems - Part 5-1: Safety requirements - Electrical, thermal and energy
EN 61800-3: 2004+A1:2012	Adjustable speed electrical power drive systems - Part 3: EMC requirements and specific test methods
EN ISO 13849-1:2015	Safety of Machinery, Safety-related parts of control systems, General principles for design
EN 62061:2005 + AC:2010 + A1:2013 + A2:2015	Safety of machinery, Functional safety of safety related electrical, electronic and programmable electronic control systems
IEC 61508 Parts 1 - 7:2010	Functional safety of electrical/ electronic/programmable electronic safety-related systems

Person authorised to complete the technical file:

P Knight  
Conformity Engineer  
Newtown, Powys, UK

**DoC authorised by:**



**Jonathan Holman-White**  
**Director of Research and Development**


**Date: 13th August 2018**

## IMPORTANT NOTICE

These electronic drive products are intended to be used with appropriate motors, controllers, electrical protection components and other equipment to form complete end products or systems. It is the responsibility of the installer to ensure that the design of the complete machine, including its safety-related control system, is carried out in accordance with the requirements of the Machinery Directive and any other relevant legislation. The use of a safety-related drive in itself does not ensure the safety of the machine. Compliance with safety and EMC regulations depends upon installing and configuring drives correctly, including using the specified input filters. The drive must be installed only by professional installers who are familiar with requirements for safety and EMC. The assembler is responsible for ensuring that the end product or system complies with all relevant laws in the country where it is to be used. For more information regarding Safe Torque Off, refer to the Product Documentation.


# 1 Safety information

## 1.1 Warnings, Cautions and Notes



A Warning contains information which is essential for avoiding a safety hazard.

**WARNING**



A Caution contains information which is necessary for avoiding a risk of damage to the product or other equipment.

**CAUTION**

**NOTE**

A Note contains information which helps to ensure correct operation of the product.

## 1.2 Important safety information. Hazards. Competence of designers and installers

This guide applies to products which control electric motors either directly (drives) or indirectly (controllers, option modules and other auxiliary equipment and accessories). In all cases the hazards associated with powerful electrical drives are present, and all safety information relating to drives and associated equipment must be observed.

Specific warnings are given at the relevant places in this guide.

Drives and controllers are intended as components for professional incorporation into complete systems. If installed incorrectly they may present a safety hazard. The drive uses high voltages and currents, carries a high level of stored electrical energy, and is used to control equipment which can cause injury. Close attention is required to the electrical installation and the system design to avoid hazards either in normal operation or in the event of equipment malfunction. System design, installation, commissioning/start-up and maintenance must be carried out by personnel who have the necessary training and competence. They must read this safety information and this guide carefully.

## 1.3 Responsibility

It is the responsibility of the installer to ensure that the equipment is installed correctly with regard to all instructions given in this guide. They must give due consideration to the safety of the complete system, so as to avoid the risk of injury both in normal operation and in the event of a fault or of reasonably foreseeable misuse.

The manufacturer accepts no liability for any consequences resulting from inappropriate, negligent or incorrect installation of the equipment.

## 1.4 Compliance with regulations

The installer is responsible for complying with all relevant regulations, such as national wiring regulations, accident prevention regulations and electromagnetic compatibility (EMC) regulations. Particular attention must be given to the cross-sectional areas of conductors, the selection of fuses or other protection, and protective ground (earth) connections. This guide contains instructions for achieving compliance with specific EMC standards.

All machinery to be supplied within the European Union in which this product is used must comply with the following directives:

2006/42/EC Safety of machinery.

2014/30/EU: Electromagnetic Compatibility.

## 1.5 Electrical hazards

The voltages used in the drive can cause severe electrical shock and/or burns, and could be lethal. Extreme care is necessary at all times when working with or adjacent to the drive. Hazardous voltage may be present in any of the following locations:

- AC and DC supply cables and connections
- Output cables and connections
- Many internal parts of the drive, and external option units

Unless otherwise indicated, control terminals are single insulated and must not be touched.

The supply must be disconnected by an approved electrical isolation device before gaining access to the electrical connections.

The STOP and Safe Torque Off functions of the drive do not isolate dangerous voltages from the output of the drive or from any external option unit.

The drive must be installed in accordance with the instructions given in this guide. Failure to observe the instructions could result in a fire hazard.

## 1.6 Stored electrical charge

The drive contains capacitors that remain charged to a potentially lethal voltage after the AC supply has been disconnected. If the drive has been energized, the AC supply must be isolated at least ten minutes before work may continue.

## 1.7 Mechanical hazards

Careful consideration must be given to the functions of the drive or controller which might result in a hazard, either through their intended behaviour or through incorrect operation due to a fault. In any application where a malfunction of the drive or its control system could lead to or allow damage, loss or injury, a risk analysis must be carried out, and where necessary, further measures taken to reduce the risk - for example, an over-speed protection device in case of failure of the speed control, or a fail-safe mechanical brake in case of loss of motor braking.

**With the sole exception of the Safe Torque Off function, none of the drive functions must be used to ensure safety of personnel, i.e. they must not be used for safety-related functions.**

The Safe Torque Off function may be used in a safety-related application. The system designer is responsible for ensuring that the complete system is safe and designed correctly according to the relevant safety standards.

The design of safety-related control systems must only be done by personnel with the required training and experience. The Safe Torque Off function will only ensure the safety of a machine if it is correctly incorporated into a complete safety system. The system must be subject to a risk assessment to confirm that the residual risk of an unsafe event is at an acceptable level for the application.

## 1.8 Access to equipment

Access must be restricted to authorized personnel only. Safety regulations which apply at the place of use must be complied with.

## 1.9 Environmental limits

Instructions in this guide regarding transport, storage, installation and use of the equipment must be complied with, including the specified environmental limits. This includes temperature, humidity, contamination, shock and vibration. Drives must not be subjected to excessive physical force.

## 1.10 Hazardous environments

The equipment must not be installed in a hazardous environment (i.e. a potentially explosive environment).

## 1.11 Motor

The safety of the motor under variable speed conditions must be ensured.

To avoid the risk of physical injury, do not exceed the maximum specified speed of the motor.

Low speeds may cause the motor to overheat because the cooling fan becomes less effective, causing a fire hazard. The motor should be installed with a protection thermistor. If necessary, an electric forced vent fan should be used.

The values of the motor parameters set in the drive affect the protection of the motor. The default values in the drive must not be relied upon. It is essential that the correct value is entered in the Motor Rated Current parameter.

## 1.12 Mechanical brake control

Any brake control functions are provided to allow well co-ordinated operation of an external brake with the drive. While both hardware and software are designed to high standards of quality and robustness, they are not intended for use as safety functions, i.e. where a fault or failure would result in a risk of injury. In any application where the incorrect operation of the brake release mechanism could result in injury, independent protection devices of proven integrity must also be incorporated.

## 1.13 Adjusting parameters

Some parameters have a profound effect on the operation of the drive. They must not be altered without careful consideration of the impact on the controlled system. Measures must be taken to prevent unwanted changes due to error or tampering.

## 1.14 Electromagnetic compatibility (EMC)

Installation instructions for a range of EMC environments are provided in the *Digitax HD M75X Series Installation and Technical Guide*. If the installation is poorly designed or other equipment does not comply with suitable standards for EMC, the product might cause or suffer from disturbance due to electromagnetic interaction with other equipment. It is the responsibility of the installer to ensure that the equipment or system into which the product is incorporated complies with the relevant EMC legislation in the place of use.

## 2 Product information

The Digitax HD M75X series is a range of high performance servo drives used as a standalone single axis or easily configured for multi-axis systems. Functionality also allows for this range of drives to be reconfigured for high performance universal AC motor control.

### 2.1 Introduction

#### Servo and Universal AC drive

This product family consists of the following variants:

- Digitax HD M750 Ethernet
- Digitax HD M751 Base
- Digitax HD M753 EtherCAT

#### Common features (Digitax HD M750, M751 and M753)

- Universal high performance open and closed loop control for induction, servo, permanent magnet and linear motors using Unidrive M motor control algorithms.
- Onboard IEC 61131-3 programmable automation and motion control
- Flexibility with speed and position measurement, supporting multiple devices and all common interfaces
- SD Media Card slot for parameter copying and data storage.
- Dual channel Safe Torque Off (STO) input.
- Simplified wiring and networking for multi-axis arrangements.
- Connect support for quick start commissioning/start up (downloadable from <http://www.drive-setup.com>).
- Option module connectable.

#### Variant description summary (Digitax HD M750, M751 and M753)

##### Digitax HD M750 Ethernet

- Ethernet fieldbus communications.
- Integrated 2 port Ethernet switch.

##### Digitax HD M751 Base

- EIA-485 serial communications interface
- Option module support as standard for configuration and flexibility

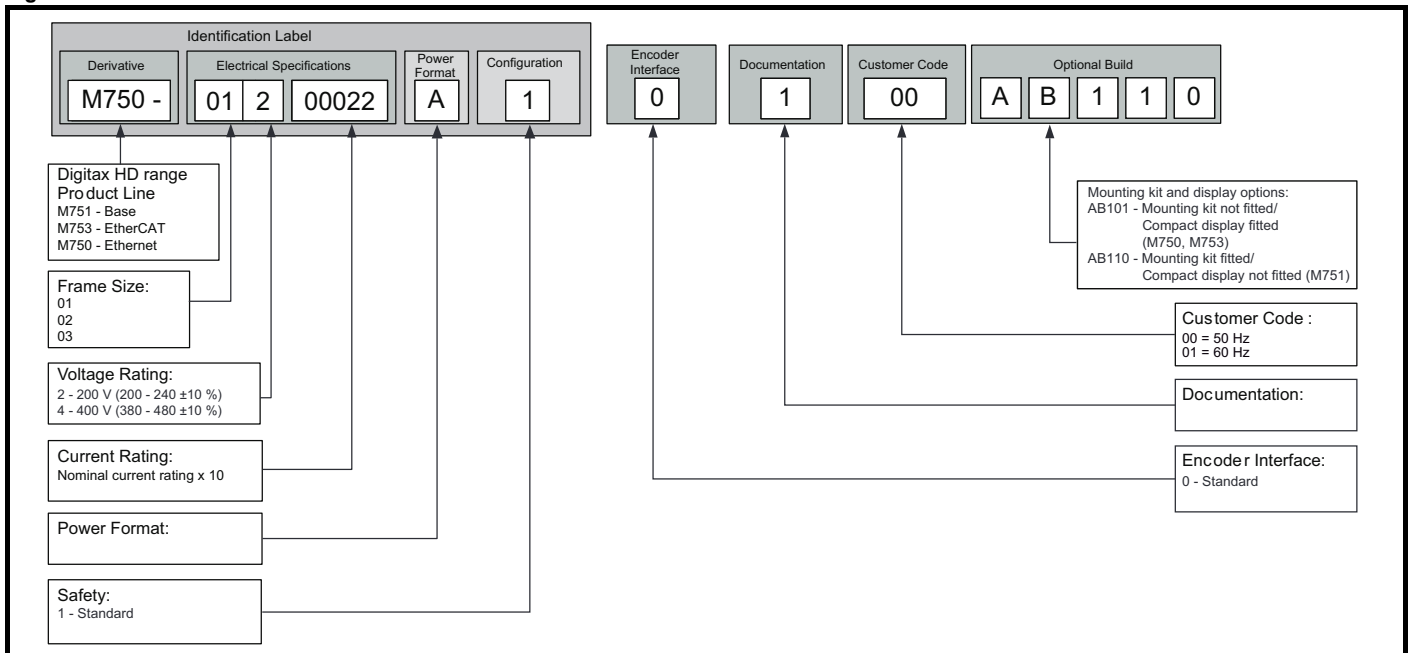
##### Digitax HD M753 EtherCAT

- Onboard EtherCAT slave for centralized motion control and accurate synchronization applications.
- 2 integrated EtherCAT ports

### 2.2 Model number

The way in which the model numbers for the Digitax HD M75X series product range are formed is illustrated below:

Figure 2-1 Model number



## 2.3 Operating modes

The drive is designed to operate in any of the following modes:

1. RFC - S
  - With position feedback sensor
  - Without position feedback sensor (Sensorless)
2. Open loop mode
  - Open loop vector mode
  - Fixed V/F mode (V/Hz)
  - Quadratic V/F mode (V/Hz)
3. RFC - A
  - With position feedback sensor
  - Without position feedback sensor (Sensorless)

As a range of high performance servo drives, the Digitax HD M75X series are initially factory configured for RFC-S mode. The operating mode will need to be re-configured for AC induction motor control (open loop or RFC-A mode).

### 2.3.1 RFC - S

Rotor Flux Control for Synchronous (permanent magnet brushless) motors (**RFC-S**) provides closed loop control with position feedback device.

#### With position feedback

For use with permanent magnet brushless motors with a feedback device installed.

The drive directly controls the speed of the motor using the feedback device to ensure the rotor speed is exactly as demanded.

Absolute position information is required from the feedback device to ensure the output voltage is accurately matched to the back EMF of the motor. Full torque is available across the entire speed range.

#### Without position feedback (Sensorless)

For permanent magnet brushless motor control without a feedback device, using current, voltages and key motor parameters for motor control.

### 2.3.2 Open loop mode

The drive applies power to the motor at frequencies varied by the user. The motor speed is a result of the output frequency of the drive and slip due to the mechanical load. The drive can improve the speed control of the motor by applying slip compensation. The performance at low speed depends on whether V/F mode or open loop vector mode is selected.

#### Open loop vector mode

The voltage applied to the motor is directly proportional to the frequency except at low speed where the drive uses motor parameters to apply the correct voltage to keep the flux constant under varying load conditions.

Typically 100 % torque is available down to 1 Hz for a 50 Hz motor.

#### Fixed V/F mode

The voltage applied to the motor is directly proportional to the frequency except at low speed where a voltage boost is provided which is set by the user. This mode can be used for multi-motor applications.

Typically 100 % torque is available down to 4 Hz for a 50 Hz motor.

#### Quadratic V/F mode

The voltage applied to the motor is directly proportional to the square of the frequency except at low speed where a voltage boost is provided which is set by the user. This mode can be used for running fan or pump applications with quadratic load characteristics or for multi-motor applications.

This mode is not suitable for applications requiring a high starting torque.

### 2.3.3 RFC-A mode

Rotor Flux Control for Asynchronous (induction) motors (**RFC-A**) encompasses closed loop vector control with a position feedback device.

#### With position feedback

For use with induction motors with a feedback device installed. The drive directly controls the speed of the motor using the feedback device to ensure the rotor speed exactly as demanded. Motor flux is accurately controlled at all times to provide full torque all the way down to zero speed.

#### Without position feedback (Sensorless)

Sensorless mode provides closed loop control without the need for position feedback by using current, voltages and key motor parameters to estimate the motor speed. It can eliminate instability traditionally associated with open loop control such as operating large motors with light loads at low frequencies.

## 2.4 Compatible position feedback devices

Table 2-1 Supported feedback devices

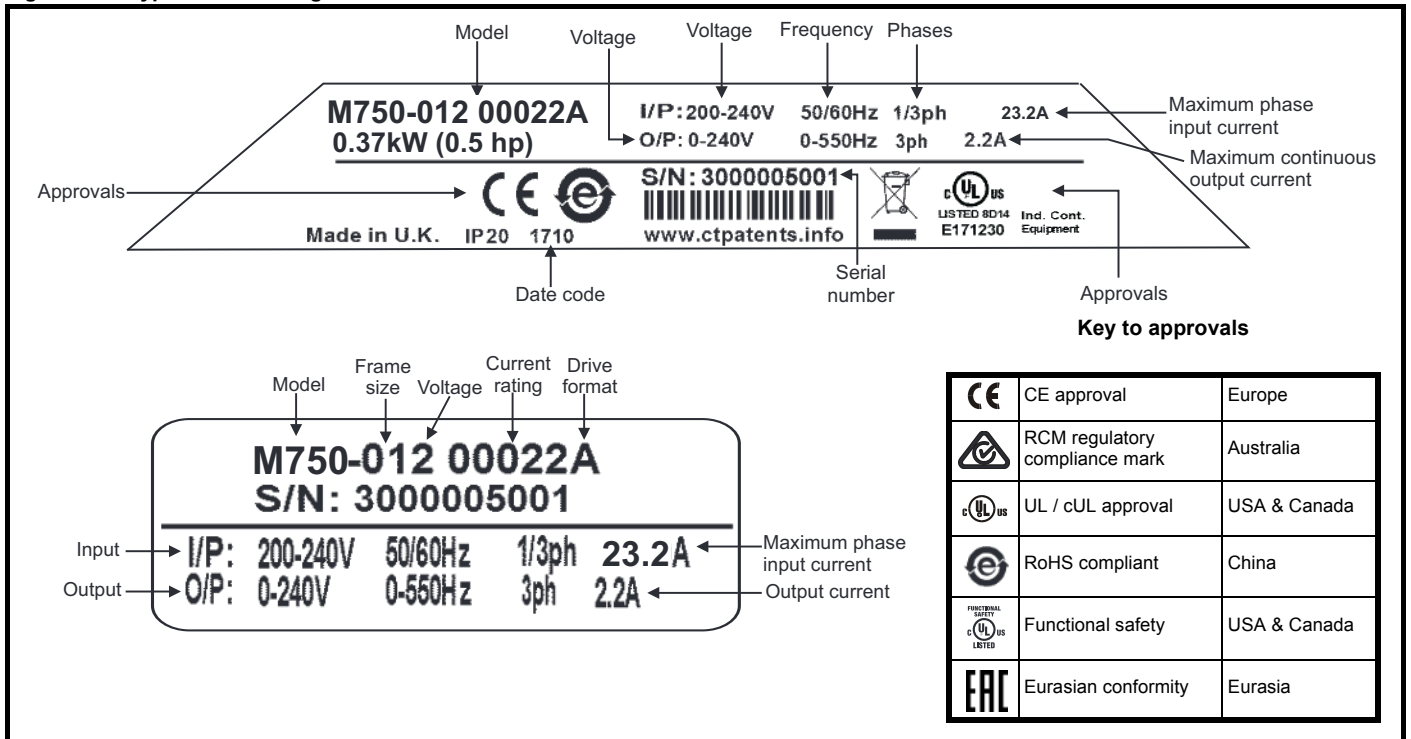
Encoder type	Pr 3.038 setting
Quadrature incremental encoders with or without marker pulse	AB (0)
Quadrature incremental encoders with UVW commutation signals for absolute position for permanent magnet motors with or without marker pulse	AB Servo (3)
Forward / reverse incremental encoders with or without marker pulse	FR (2)
Forward / reverse incremental encoders with UVW commutation signals for absolute position for permanent magnet motors with or without marker pulse	FR Servo (5)
Frequency and direction incremental encoders with or without marker pulse	FD (1)
Frequency and direction incremental encoders with UVW commutation signals for absolute position for permanent magnet motors with or without marker pulse	FD Servo (4)
Sincos incremental encoders	SC (6)
Sincos incremental with commutation signals	SC Servo (12)
Heidenhain sincos encoders with EnDat comms for absolute position	SC EnDat (9)
Stegmann sincos encoders with Hiperface comms for absolute position	SC Hiperface (7)
Sincos encoders with SSI comms for absolute position	SC SSI (11)
Sincos incremental with absolute position from single sin and cosine signals	SC SC (15)
SSI encoders (Gray code or binary)	SSI (10)
EnDat communication only encoders	EnDat (8)
Resolver	Resolver (14)
UVW commutation only encoders*	Commutation only (16)
BiSS communication only encoders	BiSS (13)
Sincos encoders with BiSS communications	SC BiSS (17)

\* This feedback device provides very low resolution feedback and should not be used for applications requiring a high level of performance.

## 2.5 Nameplate description

The following labels are attached to the drive.

Figure 2-2 Typical drive rating labels



### NOTE

#### Date code format



The date code is four numbers. The first two numbers indicate the year and the remaining numbers indicate the week of the year in which the drive was built.

Example: A date code of 1710 would correspond to week 10 of year 2017.

## 2.6 Options



All standard option modules are color-coded in order to make identification easy. All modules have an identification label on top of the module. Standard option modules can be installed to any of the available option slots on the drive. The following tables shows the color-code key and gives further details on their function.

**Table 2-2 Option module identification**

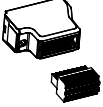
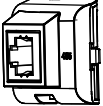
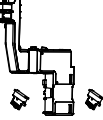
Type	Option module*	Color	Name	Further Details
Fieldbus		Purple	SI-PROFIBUS	<b>PROFIBUS option</b> PROFIBUS adapter for communications with the drive
		Medium Grey	SI-DeviceNet	<b>DeviceNet option</b> DeviceNet adapter for communications with the drive
		Light Grey	SI-CANopen	<b>CANopen option</b> CANopen adapter for communications with the drive
		Beige	SI-Ethernet	External Ethernet module that supports EtherNet/IP, Modbus TCP/IP and RTMoE. The module can be used to provide high speed drive access, global connectivity and integration with IT network technologies, such as wireless networking
		Yellow Green	SI-PROFINET V2	<b>PROFINET V2 option</b> PROFINET V2 adapter for communications with the drive Note: PROFINET V2 replaces PROFINET RT.
		Brown Red	SI-EtherCAT	<b>EtherCAT option</b> EtherCAT adapter for communications with the drive
Automation (I/O expansion)		Orange	SI-I/O	<b>Extended I/O</b> Increases the I/O capability by adding the following combinations: <ul style="list-style-type: none"> <li>Digital I/O</li> <li>Digital Inputs</li> <li>Analog Inputs (differential or single ended)</li> <li>Analog Output</li> <li>Relays</li> </ul>
Feedback		Light Brown	SI-Encoder	Incremental encoder input interface module.
		Dark Brown	SI-Universal Encoder	Additional combined encoder input and output interface supporting Incremental, SinCos, HIPERFACE, EnDAT and SSI encoders.
Automation (Applications)		Moss Green	MCI200	<b>Machine Control Studio Compatible Applications Processor</b> 2nd processor for running pre-defined and/or customer created application software.
		Moss Green	MCI210	<b>Machine Control Studio Compatible Applications Processor (with Ethernet communications)</b> 2nd processor for running pre-defined and/or customer created application software with Ethernet communications.
		Black	SI-Applications Compact	<b>SyTPPro Compatible Applications Processor (with CTNet)</b> 2nd processor for running pre-defined and/or customer created application software with CTNet support.

\*Additional SI option mounting kit required when connecting option modules where not already fitted.

**Table 2-3 Display / Keypad identification**

Type	Keypad	Name	Further Details
Display		KI-Compact display	<b>Single segment display option</b> Compact display with single character code drive status representation, node address setting and a push button reset
Keypad		Remote-Keypad RTC	<b>Remote LCD keypad option</b> Remote Keypad with a LCD display and a real time clock

**Table 2-4 Additional options**

Type	Option	Name	Further Details
Feedback		Encoder breakout kit (82700000020200)	<b>Drive encoder breakout kit</b> Provides screw terminal interface for encoder wiring.
Accessory		KI-Compact 485 adaptor (82700000020300)	<b>KI-Compact 485 adaptor</b> The M75X Remote Keypad Adaptor provides an EIA-485 port for permanent connection to a KI-Remote Keypad or the temporary attachment for PC tool connection
Accessory		SI-Option Mounting kit (9500-1055)	<b>SI-Option Mounting kit</b> When connecting SI-option modules, an additional SI-Option Mounting kit is required, when the drive is not supplied with a SI-Option Mounting kit fitted.

## 3 Mechanical installation

### 3.1 SI-Option module installation



Remove the AC/DC power as well as the 24 Vdc supply to the drive before installing / removing the option module. Failure to do so may result in damage to the product.

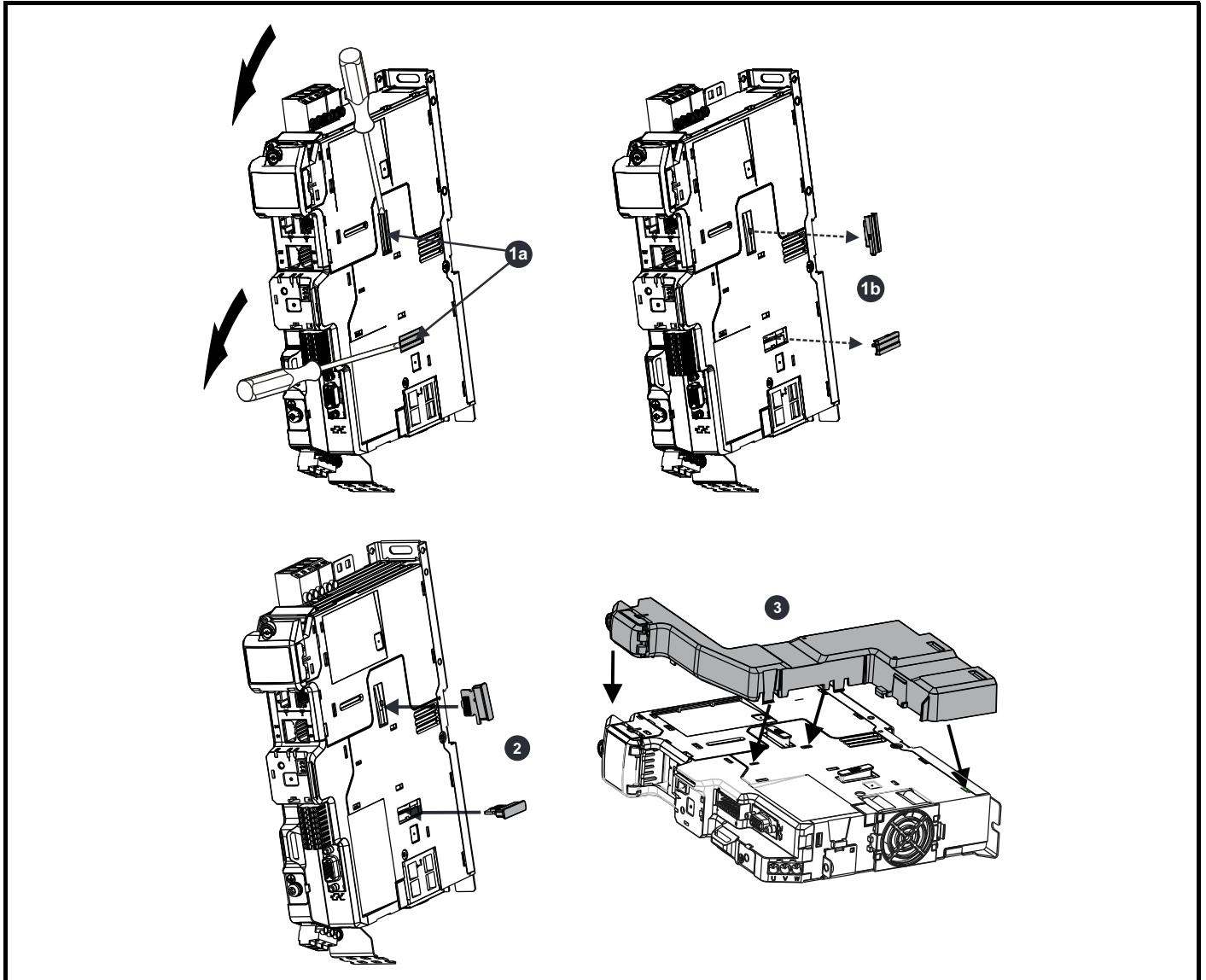


Care must be taken when handling the option module interface card to avoid contaminating the gold contacts. Gold contacts must not be touched directly, handle the interface card using the protective cover provided in the mounting kit.

When connecting SI-option modules, an additional SI-Option mounting kit is required. If the drive is not supplied with a mounting kit fitted, it can be ordered from the supplier of the drive. Refer to Table 2-4 on page 14.

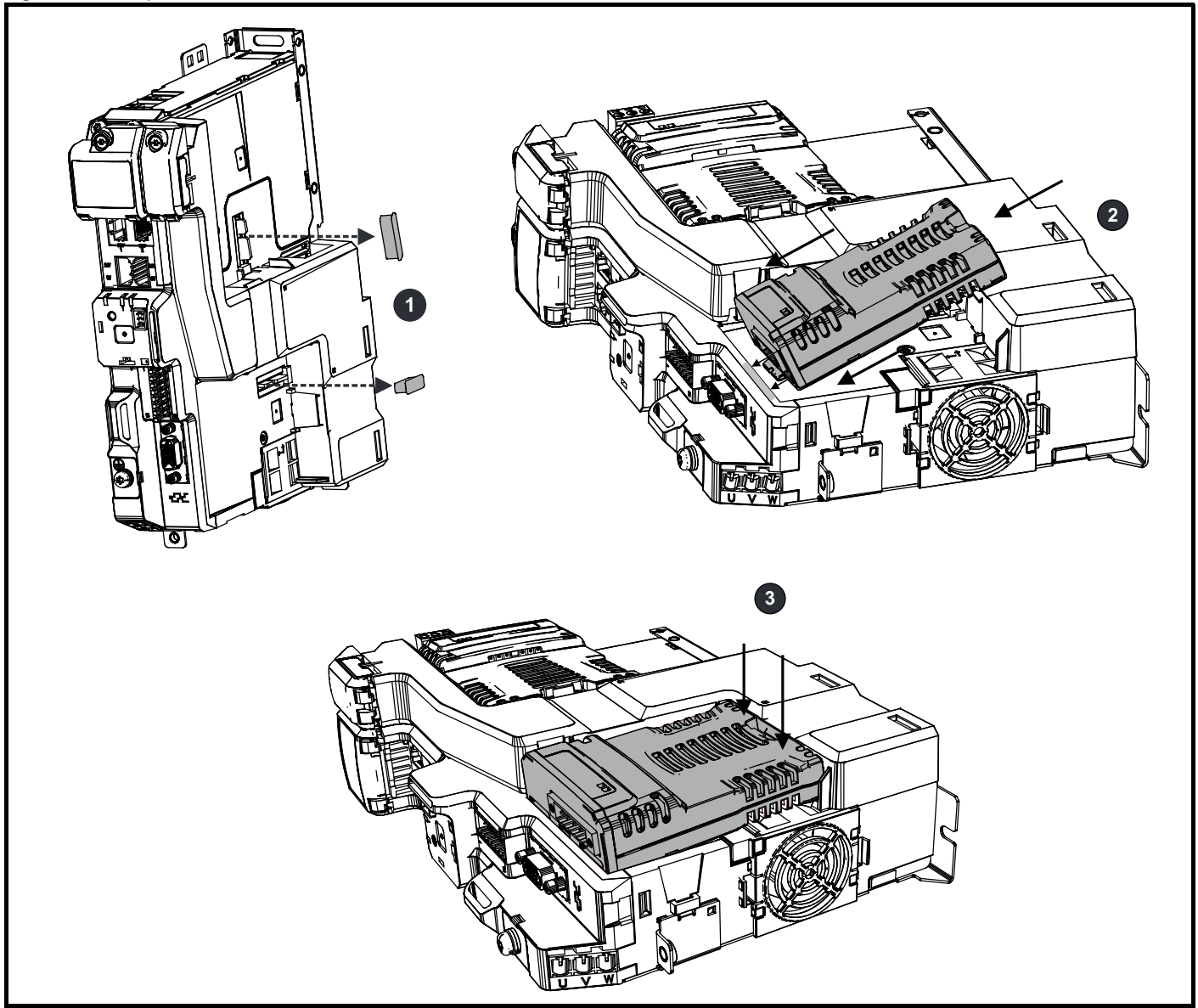
For fitting instructions, refer to Figure 3-1.

**Figure 3-1 SI-Option mounting kit Installation**



- 1a. Insert a flat head terminal screwdriver underneath the option module slot covers and prise both out in the direction shown as highlighted (1b).
2. Install the interface card into the option module slot (do not remove the protective cover). The interface card will remain at an angle with respect to the plastic.
3. Line up and clip the SI-option module support mounting frame to the drive in the direction shown.

Figure 3-2 SI-Option module installation



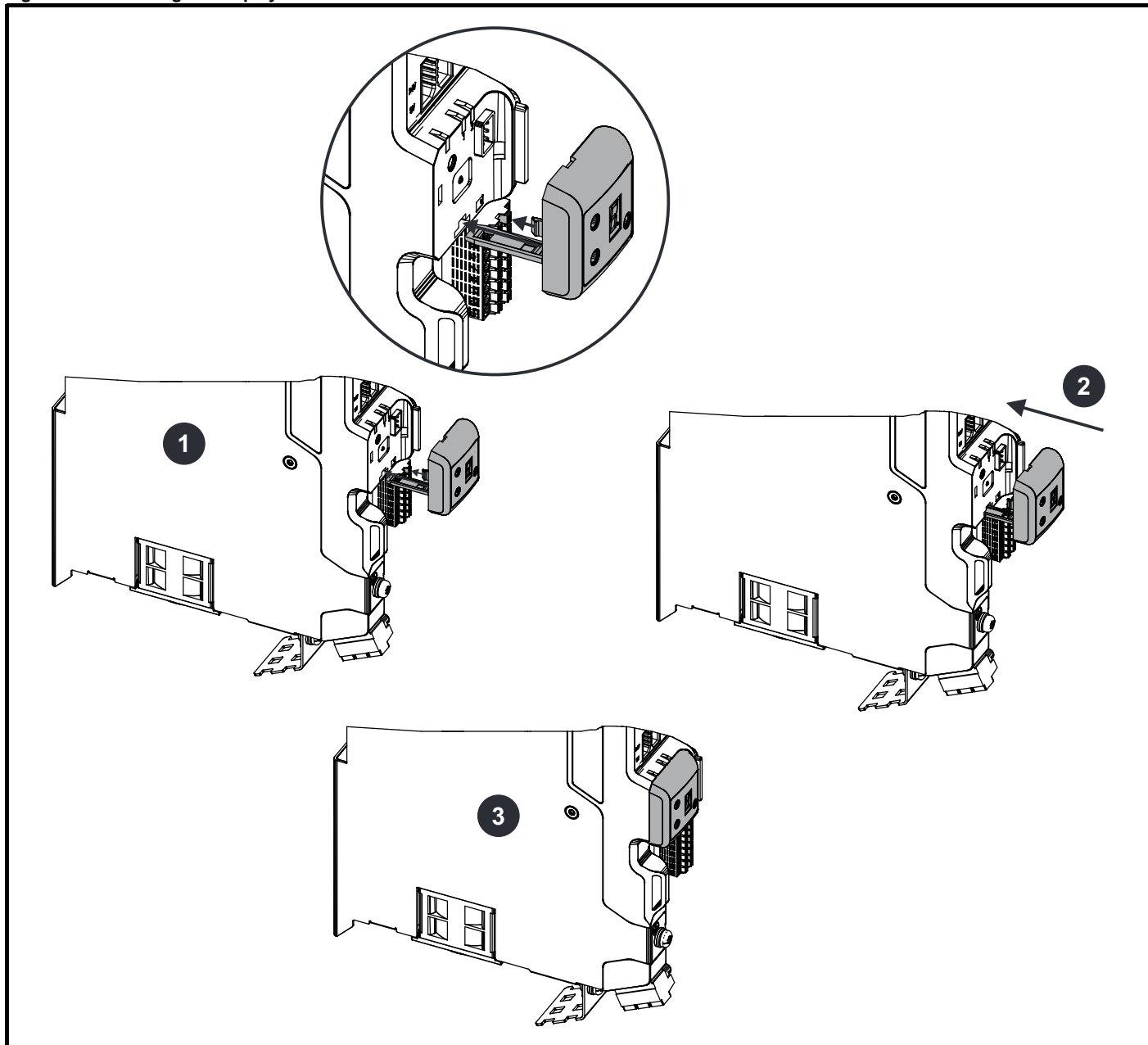
1. Remove the protective interface card cover.
2. Align and insert the option module tab into the slot on the drive plastic.
3. Once the option module tab is located into the slot on the drive, push down at the rear of the option module until it clicks into place.

**NOTE**

Once fitted, the SI-option module remains at an angle with respect to the drive.

## 3.2 KI-Compact Display installation

Figure 3-3 Installing the display

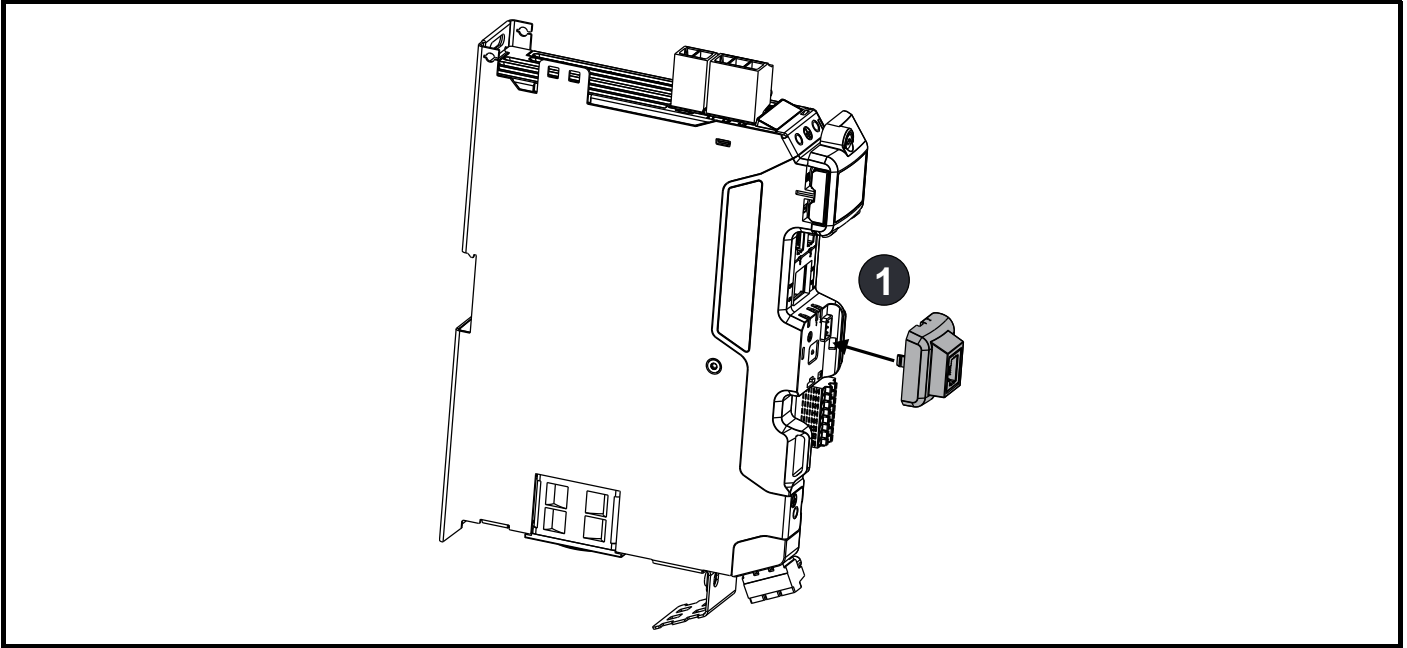


1. Align display tether with slot.
2. Slide the display and tether in the direction shown.
3. Push display until it clicks into position.

### 3.3 KI-Remote Keypad Adaptor installation

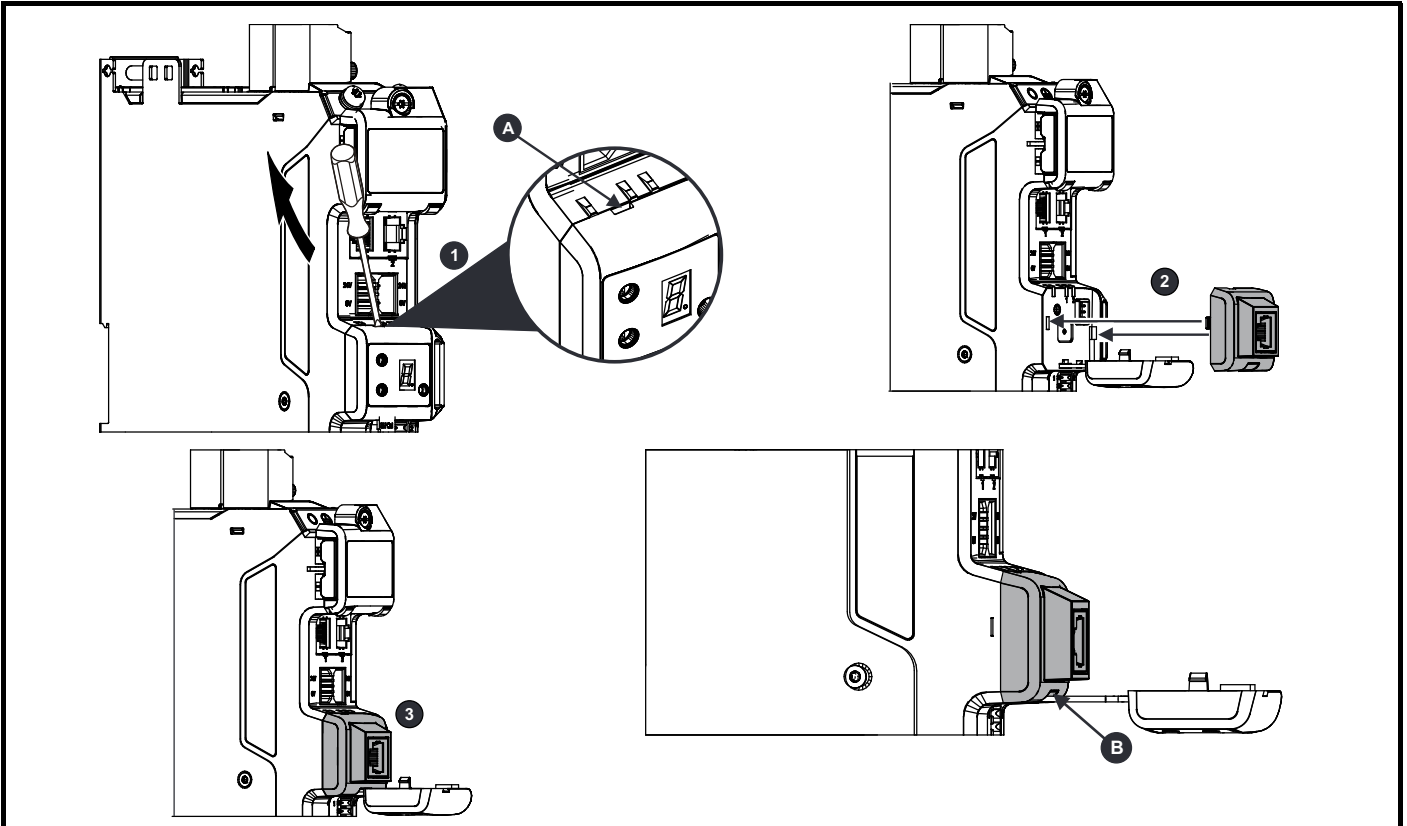
The M75X Remote Keypad Adaptor provides an EIA-485 port for permanent connection to a KI-Remote Keypad or the temporary attachment for PC tool connection. The KI-Remote Keypad Adaptor is available from the supplier of the drive. Refer to Table 2-4 *Additional options* on page 14.

**Figure 3-4** Installing the KI-Remote Keypad Adaptor without display fitted



1. Align the KI-Remote Keypad Adaptor to the display housing and push on until it clicks into place.

**Figure 3-5** Installing the KI-Remote Keypad Adaptor with display fitted



1. Unclip and pull the display away from the front cover. The tether keeps the display associated to the drive and should not be removed. A small terminal screwdriver maybe required to unclip the display. A slot in the drive plastic is provided for this purpose (A).
2. Align the Remote Keypad Adaptor with the display housing noting the position of the notch (See view B above). Install the Remote Keypad Adaptor over the display tether.
3. Push the Remote Keypad Adaptor into the housing until it clicks into place.

## 4 Electrical installation

### 4.1 External 24 Vdc supply



The drive will power down and reset if the external 24 Vdc is removed.

An external 24 Vdc supply is required to power all the low voltage circuits within the drive.

The cable length between the 24 Vdc power supply and the drive should not exceed 10 m.

The 0V connection of the external 24 Vdc power supply should be connected to the same ground connection as the drive. Where this is not possible the 0V connection of the 24 Vdc power supply should be floating.

The working voltage range of the drive 24 V power circuit is as follows:

**Table 4-1 Working voltage range of the 24 Vdc supply**

<b>1</b>	<b>0V common</b>
<b>2</b>	<b>+24 Vdc</b>
<b>All frame sizes</b>	
Nominal operating voltage	24.0 Vdc
Minimum continuous operating voltage	20.4 V
Maximum continuous operating voltage	28.8 V
Minimum start up voltage	20.4 V
Maximum fuse rating	30 A

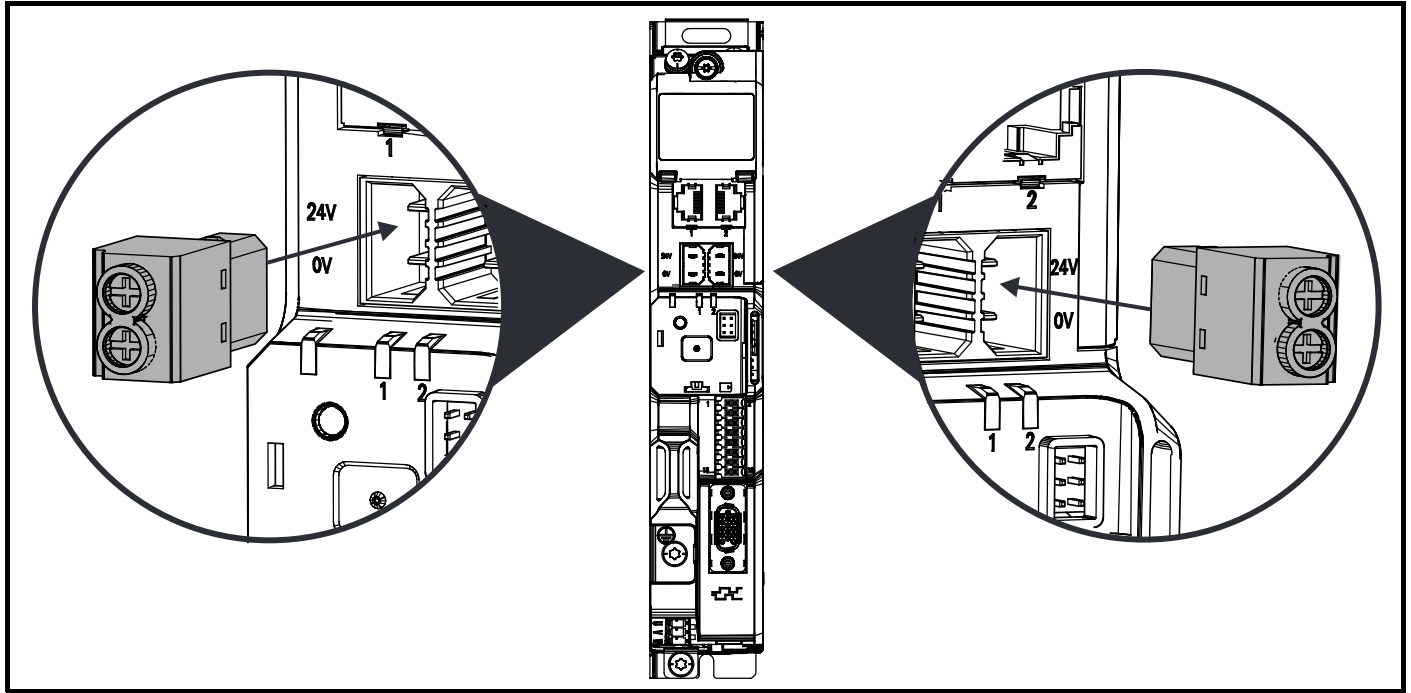
**Table 4-2 24 Vdc typical input current and power requirements**

Model / Option / Feature	Frame size	Typical input current (mA) @ 24 V	Typical input power (W)
Digitax HD M75X drive module	1, 2	894	21.5
	3	1039	25
SI-option module	Per module	450	11
High current brake output	All	1200	28.8
KI-Compact display	All	10	0.24
KI-Remote LCD keypad	All	73	1.75

**NOTE**

During start up of the external 24 Vdc supply, allow for an additional 1 A for 300 ms.

**Figure 4-1 Location of external 24 Vdc supply terminals**



**NOTE**

The 24 Vdc supply connector has been designed to allow wiring from either the left or right hand side of the drive. The same plug should be used but attention is required to the polarity of the wiring. If it is reversed, the drive will not power up but will not be damaged.

For stand alone drives connection to either terminal is permissible.

## 4.2 Low voltage operation

The drive is able to operate from a low voltage DC supply with a range from 24 Vdc to the maximum DC volts. It is possible for the drive to go from operating on a normal line power supply voltage to operating on a much lower supply voltage without interruption.

Going from low voltage operation to normal mains operation requires the inrush current to be controlled. This may be provided externally. If not, the drive supply can be interrupted to utilise the normal soft starting method in the drive.

To fully exploit the new low voltage mode of operation, the under voltage trip level is now user programmable. For application data, contact the supplier of the drive.

The working voltage range of the low voltage DC power supply is as follows:

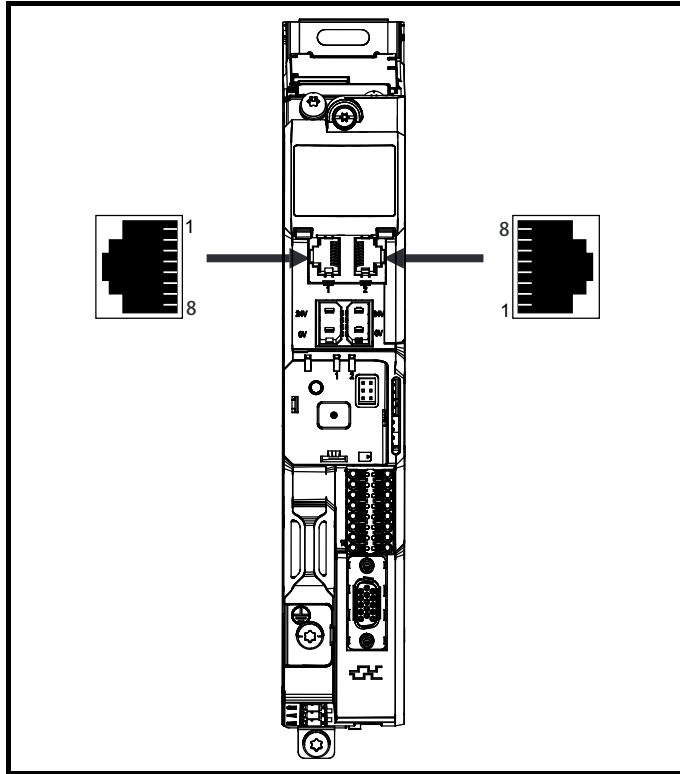
Minimum continuous operating voltage:	26 Vdc
Minimum start up voltage:	32 Vdc
Maximum over voltage trip threshold:	230 Vac drives: 415 Vdc
	400 Vac drives: 830 Vdc

### 4.3 Communication connections

The Digitax HD M750 drive offers Ethernet fieldbus communications. This enables the drive set-up, operation and monitoring to be carried out with a PC or controller if required.

Care must be taken to ensure the correct interface is fitted before a connection is made to the interface, failure to ensure this may result in damage to the interface and/or communication device.

**Figure 4-2 Location of the comms connectors**



The M750 provides two RJ45 connections with an Ethernet switch for easy network creation.

Standard UTP (unshielded twisted pair) or STP (shielded twisted pair) cables are supported. It is recommended that a minimum specification CAT5e is used in new installations. As the drive supports the 'Auto cross-over detection' a cross-over cable is not required.

The shell of the RJ45 connector is capacitively coupled to ground.

**Table 4-3 Ethernet port pin-outs**

Pin	Description
1	Transmit +
2	Transmit -
3	Receive +
4	Not used
5	Not used
6	Receive -
7	Not used
8	Not used

### 4.4 Control connections

#### 4.4.1 Digitax HD M75X control connections

**Table 4-4 The control connections consist of:**

Function	Qty	Control parameters available	Terminal number
Differential analog input	1	Offset, invert, scaling	9, 10
Digital input	2	Destination, invert, logic select	11, 13
Digital output	2	Source, invert, logic select	14, 16
Drive enable (Safe Torque Off)	2		2, 6
+24 V User output	1	Source, invert	12
0V common	7		1, 3, 4, 5, 7, 8, 15

**Key:**

Destination parameter:	Indicates the parameter which is being controlled by the terminal / function
Source parameter:	Indicates the parameter being output by the terminal

All analog terminal functions can be programmed in menu 7.

All digital terminal functions can be programmed in menu 8.



**WARNING**

The control circuits are isolated from the power circuits in the drive by basic insulation (single insulation) only. The installer must ensure that the external control circuits are insulated from human contact by at least one layer of insulation (supplementary insulation) rated for use at the AC supply voltage.



**WARNING**

If the control circuits are to be connected to other circuits classified as Safety Extra Low Voltage (SELV) (e.g. to a personal computer), an additional isolating barrier must be included in order to maintain the SELV classification.



**CAUTION**

If any of the digital inputs (including the drive enable input) are connected in parallel with an inductive load (i.e. contactor or motor brake) then suitable suppression (i.e. diode or varistor) should be used on the coil of the load. If no suppression is used then over voltage spikes can cause damage to the digital inputs and outputs on the drive.

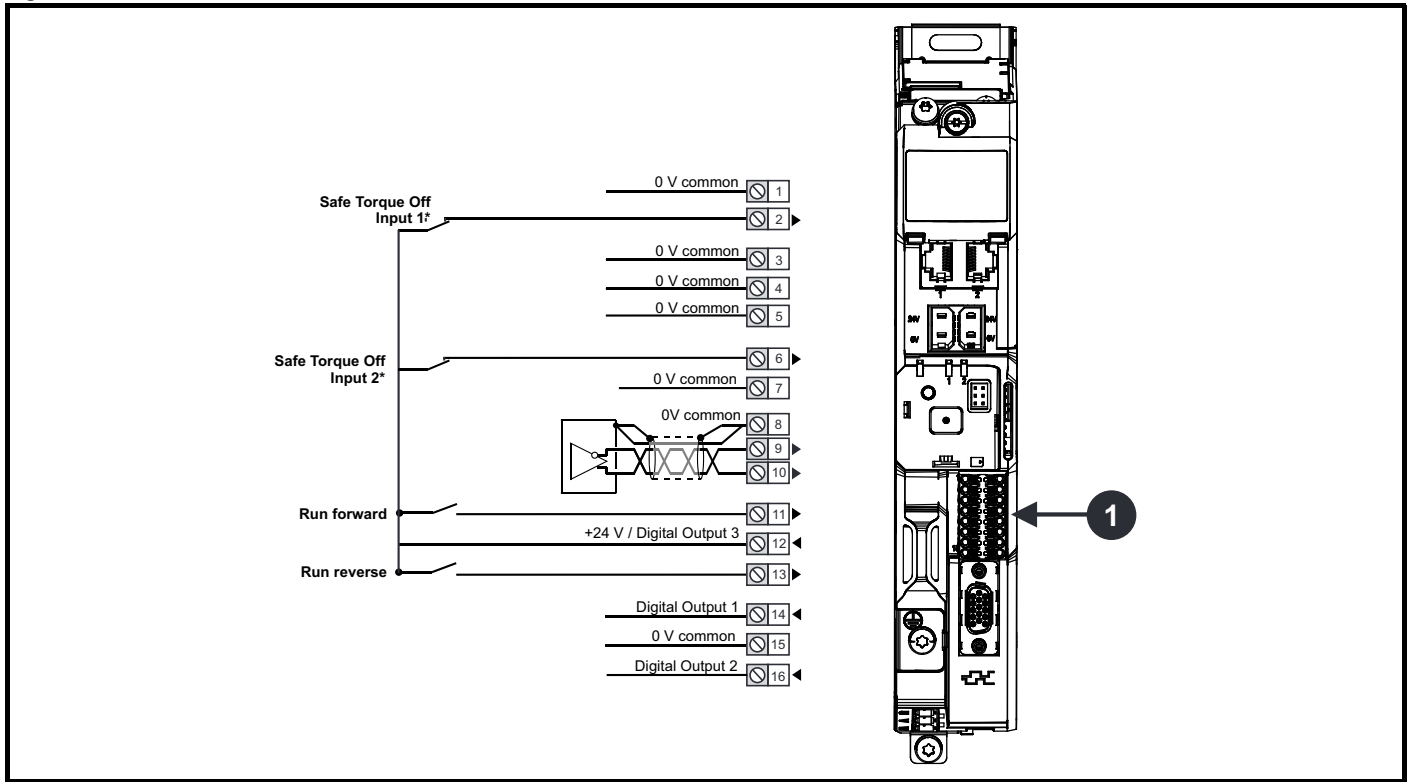
**NOTE**

Any signal cables which are carried inside the motor cable (i.e. motor thermistor, motor brake) will pick up large pulse currents via the cable capacitance. The shield of these signal cables must be connected to ground close to the point of exit of the motor cable, to avoid this noise current spreading through the control system.

**NOTE**

The control circuits are isolated from the power circuits in the drive by reinforced insulation.

**Figure 4-3 Default control terminal functions**



1. Polarized signal connections.

\* The Safe Torque Off / Drive enable terminal is a positive logic input only

#### 4.4.2 Digitax HD M75X control terminal specification

1	0V common
3	0V common
4	0V common
5	0V common
7	0V common
8	0V common
15	0V common
Function	Common connection for all external devices. Internally connected to ground.

<b>2</b>	<b>Safe Torque Off function input 1 (drive enable)</b>
<b>6</b>	<b>Safe Torque Off function input 2 (drive enable)</b>
Type	Positive logic only digital input
Voltage range	0V to +24 V
Absolute maximum applied voltage	30 V
Logic Threshold	10 V ±5 V
Low state maximum voltage for disable to SIL3 and PL e	5 V
Impedance	> 4 mA @15 V (IEC 61131-2, type 1, 3.3 kΩ)
Low state maximum current for disable to SIL3 and PL e	< 0.5 mA
Response time	Nominal: 8 ms Maximum: 20 ms
The Safe Torque Off function may be used in a safety-related application in preventing the drive from generating torque in the motor to a high level of integrity. The system designer is responsible for ensuring that the complete system is safe and designed correctly according to the relevant safety standards. If the Safe Torque Off function is not required, these terminals are used for enabling the drive.	

Refer to section 4.6 *Safe Torque Off (STO)* on page 29 for further information.

Analog input	
<b>9</b>	Inverting input
<b>10</b>	Non-inverting input
Default function	Frequency/speed reference
Type of input	Bipolar differential analog voltage
Mode controlled by:	Pr <b>07.007</b>
Operating in Voltage mode	
Full scale voltage range	$\pm 10\text{ V} \pm 2\%$
Maximum offset	$\pm 10\text{ mV}$
Absolute maximum voltage range	$\pm 36\text{ V}$ relative to 0V
Absolute maximum differential input voltage	$\pm 36\text{ V}$
Working common mode voltage range	$\pm 13\text{ V}$ relative to 0V
Input resistance	$\geq 100\text{ k}\Omega$
Monotonic	Yes (including 0V)
Dead band	None (including 0V)
Jumps	None (including 0V)
Maximum offset	20 mV
Maximum non linearity	0.3 % of input
Maximum gain asymmetry	0.5 %
Input filter bandwidth single pole	$\sim 3\text{ kHz}$
Resolution	12 bits (11 bits plus sign)
Sample / update period	250 $\mu\text{s}$ with destinations Pr <b>01.036</b> , Pr <b>01.037</b> , Pr <b>03.022</b> or Pr <b>04.008</b> in RFC-A and RFC-S modes. 4 ms for open loop mode and all other destinations in RFC-A or RFC-S modes.

11 Digital Input 4	
13 Digital Input 5	
Terminal 11 default function	RUN FORWARD input
Terminal 13 default function	RUN REVERSE input
Type	Negative or positive logic digital inputs
Voltage range	0V to +24 V
Absolute maximum applied voltage range	-3 V to +30 V
Impedance	$> 2\text{ mA} @ 15\text{ V}$ (IEC 61131-2, type 1)
Input thresholds	$10\text{ V} \pm 0.8\text{ V}$ (IEC 61131-2, type 1)
Sample / Update period	250 $\mu\text{s}$ when configured as an input with destinations Pr <b>06.035</b> or Pr <b>06.036</b> . 600 $\mu\text{s}$ when configured as an input with destination Pr <b>06.029</b> . 2 ms in all other cases.

12 +24 V user output / Digital Output 3 (selectable)	
Terminal 12 default function	+24 V user output
Programmability	Can be switched on or off to act as a third digital output (positive logic only) by setting the source Pr <b>08.028</b> and source invert Pr <b>08.018</b>
Nominal output current	100 mA
Maximum output current	100 mA 200 mA (total including DO1)
Protection	Current limit and trip
Sample / update period	2 ms when configured as an output (output will only change at the update rate of the source parameter if slower).

14 Digital Output 1	
Terminal 14 default function	AT ZERO SPEED output
Type	Positive logic voltage source outputs
Operating as an output	
Nominal maximum output current	100 mA
Maximum output current	200 mA (combined with +24 V user output/DO3)
Voltage range	0V to +24 V
Sample / Update period	2 ms (output will only change at the update rate of the source parameter)

16 Digital Output 2	
Terminal 16 default function	High current motor brake output
Type	Positive logic voltage source outputs
Operating as an output	
Nominal output current	1 A (1.3 A max)
Voltage range	0V to +24 V
Sample / Update period	2 ms (output will only change at the update rate of the source parameter)

## 4.5 Position feedback connections

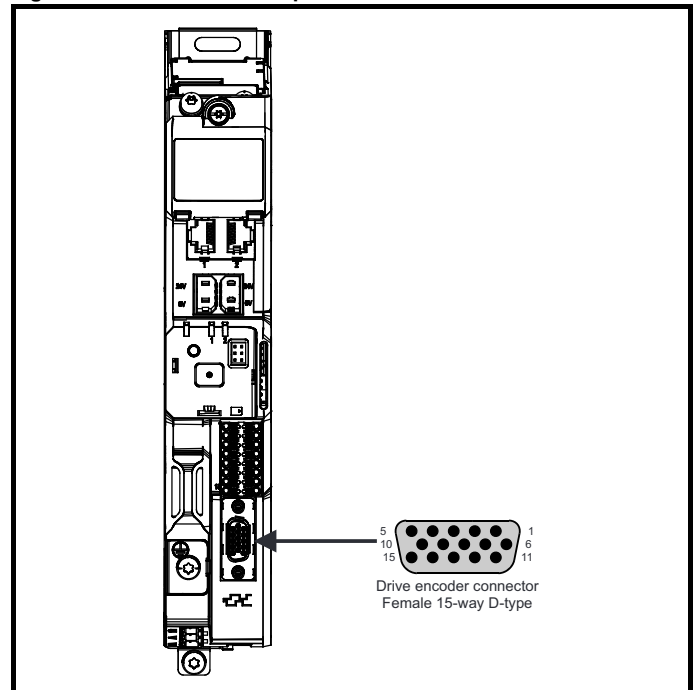
The following functions are provided via the 15-way high density D-type connector on the drive:

- Two position feedback interfaces (P1 and P2).
- One encoder simulation output.
- Two freeze trigger inputs (marker inputs).
- One thermistor input.

The P1 position interface is always available but the availability of the P2 position interface and the encoder simulation output depends on the position feedback device used on the P1 position interface, as shown in Table 4-7.

### 4.5.1 Location of position feedback connector

Figure 4-4 Location of the position feedback



## 4.5.2 Compatible position feedback devices

**Table 4-5 Supported feedback devices on the P1 position interface**

Encoder type	Pr 03.038 setting
Quadrature incremental encoders with or without marker pulse	AB (0)
Quadrature incremental encoders with UVW commutation signals for absolute position for permanent magnet motors with or without marker pulse	AB Servo (3)
Forward / reverse incremental encoders with or without marker pulse	FR (2)
Forward / reverse incremental encoders with UVW commutation signals for absolute position for permanent magnet motors with or without marker pulse	FR Servo (5)
Frequency and direction incremental encoders with or without marker pulse	FD (1)
Frequency and direction incremental encoders with UVW commutation signals for absolute position for permanent magnet motors with or without marker pulse	FD Servo (4)
Sincos incremental encoders	SC (6)
Sincos incremental with commutation signals	SC Servo (12)
Heidenhain sincos encoders with EnDat comms for absolute position	SC EnDat (9)
Stegmann sincos encoders with Hiperface comms for absolute position	SC Hiperface (7)
Sincos encoders with SSI comms for absolute position	SC SSI (11)
Sincos incremental with absolute position from single sin and cosine signals	SC SC (15)
SSI encoders (Gray code or binary)	SSI (10)
EnDat communication only encoders	EnDat (8)
Resolver	Resolver (14)
UVW commutation only encoders*	Commutation only (16)
BiSS communication only encoders	BiSS (13)
Sincos encoders with BiSS communications	SC BiSS (17)

\* This feedback device provides very low resolution feedback and should not be used for applications requiring a high level of performance

**Table 4-6 Supported feedback devices on the P2 position interface**

Encoder type	Pr 03.138 setting
Quadrature incremental encoders with or without marker pulse	AB (1)
Frequency and direction incremental encoders with or without marker pulse	FD (2)
Forward / reverse incremental encoders with or without marker pulse	FR (3)
EnDat communication only encoders	EnDat (4)
SSI encoders (Gray code or binary)	SSI (5)
BiSS communication only encoders	BiSS (6)

Table 4-7 shows the possible combinations of position feedback device types connected to the P1 and P2 position interfaces and the availability of the encoder simulation output.

**Table 4-7 Availability of the P2 position feedback interface and the encoder simulation output**

Functions		
P1 Position feedback interface	P2 Position feedback interface	Encoder Simulation Output
AB Servo FD Servo FR Servo SC Servo SC SC Commutation only	None	None
AB FD FR SC Resolver SC Hiperface	AB, FD, FR EnDat, SSI, BiSS	None
	None	Full
SC EnDat SC SSI SC BiSS	AB, FD, FR (No Z marker pulse input) EnDat, SSI (with freeze input), BiSS	None
	None	No Z marker pulse output
EnDat SSI BiSS	AB, FD, FR EnDat, SSI (with freeze input), BiSS	None
	None	Full
	EnDat, SSI, BiSS	No Z marker pulse output

The priority of the position feedback interfaces and the encoder simulation output on the 15-way D-type is assigned in the following order from the highest priority to the lowest.

- P1 position interface (highest)
- Encoder simulation output
- P2 position interface (lowest)

For example, if an AB Servo type position feedback device is selected for use on the P1 position interface, then both the encoder simulation output and the P2 position interface will not be available as this device uses all connections of the 15-way D-type connector. Also, if an AB type position feedback device is selected for use on the P1 position interface and Pr **03.085** is set to a valid source for the encoder simulation output, then the P2 position interface will not be available.

Depending on the device type used on the P1 position interface, the encoder simulation output may not be able support a marker pulse output (e.g. SC EnDat or SC SSI device types). Pr **03.086** shows the status of the encoder simulation output indicating whether the output is disabled, no marker pulse is available or full encoder simulation is available.

**NOTE**

When using the P1 and P2 position interfaces and the encoder simulation output together, the P2 position interface uses alternative connections on the 15-way D-type connector. Pr **03.172** shows the status of the P2 position interface and indicates if alternative connections are being used for the P2 position interface.

### 4.5.3 Position feedback connection details

Table 4-8 P1 Position feedback connection details

P1 Position feedback interface Pr 03.038	Connections														
	1	2	3	4	5	6	7	8	9	10	11	12	13	14	15
AB (0)	A	A\	B	B\	Z	Z\									
FD (1)	F	F\	D	D\	Z	Z\									
FR (2)	F	F\	R	R\	Z	Z\									
AB Servo (3)	A	A\	B	B\	Z	Z\	U	U\	V	V\	W	W\			
FD Servo (4)	F	F\	D	D\	Z	Z\	U	U\	V	V\	W	W\			
FR Servo (5)	F	F\	R	R\	Z	Z\	U	U\	V	V\	W	W\			
SC (6)	A (Cos)	A\ (Cos\)	B (Sin)	B\ (Sin\)	Z	Z\									
SC Hiperface (7)	Cos	Cosref	Sin	Sinref	DATA	DATA\									
EnDat (8)	DATA	DATA\	CLK	CLK\	Freeze	Freeze\									
SC EnDat (9)	A	A\	B	B\	DATA	DATA\					CLK	CLK\	+V	0V	Th
SSI (10)	DATA	DATA\	CLK	CLK\	Freeze	Freeze\									
SC SSI (11)	A (Cos)	A\ (Cos\)	B (Sin)	B\ (Sin\)	DATA	DATA\					CLK	CLK\			
SC Servo (12)	A (Cos)	A\ (Cos\)	B (Sin)	B\ (Sin\)	Z	Z\	U	U\	V	V\	W	W\			
BiSS (13)	DATA	DATA\	CLK	CLK\	Freeze	Freeze\									
Resolver (14)	Cos H	Cos L	Sin H	Sin L	Ref H	Ref L									
SC SC (15)	A (Cos)	A\ (Cos\)	B (Sin)	B\ (Sin\)	Z	Z\	C*1	C\*1	D*2	D\*2	Freeze2	Freeze2\			
Commutation Only (16)							U	U\	V	V\	W	W\			
SC BiSS (17)	A (Cos)	A\ (Cos\)	B (Sin)	B\ (Sin\)	DATA	DATA\					CLK	CLK\			

\*1 - One cosine wave per revolution

\*2 - One sine wave per revolution

Greyed cells are for P2 position feedback connections or simulated encoder outputs.

**NOTE**

Freeze and Freeze\ on terminals 5 and 6 are for Freeze input 1. Freeze2 and Freeze2\ on terminals 11 and 12 are for Freeze input 2.

**Table 4-9 P2 Position feedback and encoder simulation output connection details**

P1 Position feedback interface Pr 03.038	P2 Position feedback interface Pr 03.138	Encoder Simulation Output	Connections							
			5	6	7	8	9	10	11	12
AB (0) FD (1) FR (2) SC (6) SC Hiperface (7) Resolver (14)	AB (1)	Disabled*1			A	A\	B	B\	Z	Z\
	FD (2)				F	F\	D	D\	Z	Z\
	FR (3)				F	F\	R	R\	Z	Z\
	EnDat (4) SSI (5) BiSS (6)				DATA	DATA\	CLK	CLK\	Freeze2	Freeze2\
	None (0)	AB			Asim	Asim\	Bsim	Bsim\	Zsim	Zsim\
		FD			Fsim	Fsim\	Dsim	Dsim\	Zsim	Zsim\
		FR			Fsim	Fsim\	Rsim	Rsim\	Zsim	Zsim\
		SSI			DATAsim	DATAsim\	CLKsim	CLKsim\		
SC EnDat (9) SC SSI (11) SC BiSS (17)	AB (1)	Disabled*1			A	A\	B	B\		
	FD (2)				F	F\	D	D\		
	FR (3)				F	F\	R	R\		
	EnDat (4) SSI (5) BiSS (6)				DATA	DATA\	CLK	CLK\		
	None (0)	AB			Asim	Asim\	Bsim	Bsim\		
		FD			Fsim	Fsim\	Dsim	Dsim\		
		FR			Fsim	Fsim\	Rsim	Rsim\		
		SSI			DATAsim	DATAsim\	CLKsim	CLKsim\		
EnDat (8) SSI (10) BiSS (13)	AB (1)	Disabled*1			A	A\	B	B\	Z	Z\
	FD (2)				F	F\	D	D\	Z	Z\
	FR (3)				F	F\	R	R\	Z	Z\
	EnDat (4) SSI (5) BiSS (6)				DATA	DATA\	CLK	CLK\	Freeze2	Freeze2\
	None (0)	AB			Asim	Asim\	Bsim	Bsim\	Zsim	Zsim\
		FD			Fsim	Fsim\	Dsim	Dsim\	Zsim	Zsim\
		FR			Fsim	Fsim\	Rsim	Rsim\	Zsim	Zsim\
		SSI			DATAsim	DATAsim\	CLKsim	CLKsim\		
EnDat (8) SSI (10) BiSS (13) (with no Freeze inputs)	EnDat (4) SSI (5) BiSS (6)	AB	DATA	DATA\	Asim	Asim\	Bsim	Bsim\	CLK	CLK\
		FD	DATA	DATA\	Fsim	Fsim\	Dsim	Dsim\	CLK	CLK\
		FR	DATA	DATA\	Fsim	Fsim\	Rsim	Rsim\	CLK	CLK\
		SSI	DATA	DATA\	DATAsim	DATAsim\	CLKsim	CLKsim\	CLK	CLK\

\*1 The encoder simulation output is disabled when Pr 03.085 is set to zero.

**NOTE**

The termination resistors are always enabled on the P2 position interface. Wire break detection is not available when using AB, FD or FR position feedback device types on the P2 position interface.

#### 4.5.4 Position feedback terminal specifications

<b>1</b>	<b>A, F, Cosref, Data, Cos H</b>
<b>2</b>	<b>A, F, Cosref, Data, Cos L</b>
<b>AB (0), FD (1), FR (2), AB Servo (3), FD Servo(4), FR Servo (5)</b>	
Type	EIA-485 differential receivers
Maximum input frequency	500 kHz
Line loading	< 2 unit loads
Line termination components	120 Ω (switchable)
Working common mode range	-7 V to +12 V
<b>SC Hiperface (7), SC EnDat (9), SC SSI (11), SC Servo (12), SC SC (15), SC BiSS (17)</b>	
Type	Differential voltage
Maximum Signal level	1.25 V peak to peak (sin with regard to sinref and cos with regard to cosref)
Maximum input frequency	See Table 4-10.
Maximum applied differential voltage and common mode voltage range	±4 V
<b>Resolution:</b> The sine wave frequency can be up to 500 kHz but the resolution is reduced at high frequency. Table 4-10 shows the number of bits of interpolated information at different frequencies and with different voltage levels at the drive encoder port.	
<b>EnDat (8), SSI (10), BiSS (13)</b>	
Type	EIA-485 differential receivers
Maximum input frequency	4 MHz
Line termination components	120 Ω (switchable)
Working common mode range	-7 V to +12 V
<b>Resolver (14)</b>	
Type	2 Vrms sinusoidal signal
Operating Frequency	6 - 8 kHz
Input voltage	0.6 Vrms
Minimum impedance	85 Ω
<b>Common to All</b>	
Absolute maximum applied voltage relative to 0V	-9 V to 14 V
Maximum differential voltage between terminals (with termination resistors enabled)	±6 V

**NOTE**

The position feedback input will accept 5 V TTL differential signals.

<b>3</b>	<b>B, D, R Sinref, Clock, Sin H</b>
<b>4</b>	<b>B, D, R, Sinref, Clock, Sin L</b>
<b>AB (0), FD (1), FR (2), AB Servo (3), FD Servo(4), FR Servo (5)</b>	
Type	EIA-485 differential receivers
Maximum input frequency	500 kHz
Line loading	< 2 unit loads
Line termination components	120 Ω (switchable)
Working common mode range	-7 V to +12 V
<b>SC Hiperface (7), SC EnDat (9), SC SSI (11), SC Servo (12), SC SC (15), SC BiSS (17)</b>	
Type	Differential voltage
Maximum Signal level	1.25 V peak to peak (sin with regard to sinref and cos with regard to cosref)
Maximum input frequency	See Table 4-10.
Maximum applied differential voltage and common mode voltage range	±4 V
<b>Resolution:</b> The sine wave frequency can be up to 500 kHz but the resolution is reduced at high frequency. Table 4-10 shows the number of bits of interpolated information at different frequencies and with different voltage levels at the drive encoder port.	
<b>EnDat (8), SSI (10), BiSS (13)</b>	
Type	EIA-485 differential receivers
Maximum input frequency	4 MHz
Line termination components	120 Ω (switchable)
Working common mode range	-7 V to +12 V
<b>Resolver (14)</b>	
Type	2 Vrms sinusoidal signal
Operating Frequency	6 - 8 kHz
Input voltage	0.6 Vrms
Minimum impedance	85 Ω
<b>Common to All</b>	
Absolute maximum applied voltage relative to 0V	-9 V to 14 V
Maximum differential voltage between terminals (with termination resistors enabled)	±6 V

<b>5</b>	<b>Z, Data, Freeze, Ref H</b>
<b>6</b>	<b>ZI, Data, FreezeI, Ref L</b>
<b>AB (0), FD (1), FR (2), AB Servo (3), FD Servo(4), FR Servo (5), SC SC (15)</b>	
Type	EIA-485 differential receivers
Maximum input frequency	512 kHz
Line loading	< 2 unit loads
Line termination components	120 Ω (switchable)
Working common mode range	-7 V to +12 V
<b>SC Hiperface (7), SC EnDat (9), SC SSI (11), SC Servo (12), SC BiSS (17)</b>	
Type	EIA-485 differential receivers
Maximum input frequency	4 MHz
Line termination components	120 Ω (switchable)
Working common mode range	-7 V to +12 V
<b>EnDat (8), SSI (10)</b>	
Type	EIA-485 differential receivers
Maximum input frequency	4 MHz
Line termination components	120 Ω (switchable)
Working common mode range	-7 V to +12 V
<b>Resolver (14)</b>	
Type	Differential voltage
Nominal voltage	0 – 2 Vrms depending on turns ratio
Operating frequency	6 - 8 KHz
Minimum impedance	85 Ω
<b>Common to All</b>	
Absolute maximum applied voltage relative to 0V	-9 V to 14 V
Maximum differential voltage between terminals (with termination resistors enabled)	±6 V

<b>7</b>	<b>U, C, Not used, Not used</b>
<b>8</b>	<b>UI, CI, Not used, Not used</b>
<b>AB Servo (3), FD Servo(4), FR Servo (5), SC Servo (12)</b>	
Type	EIA-485 differential receivers
Maximum input frequency	512 kHz
Line loading	1 unit load
Line termination components	120 Ω (switchable)
Working common mode range	-7 V to +12 V
<b>SC SC (15)</b>	
Type	Differential voltage
Maximum Signal level	1.25 V peak to peak (sin with regard to sinref and cos with regard to cosref)
Maximum input frequency	See Table 4-10.
Maximum applied differential voltage and common mode voltage range	±4 V
<b>EnDat (8), SSI (10), BiSS (13)</b>	
Not used	
<b>Resolver (14)</b>	
Not used	
<b>Common to All</b>	
Absolute maximum applied voltage relative to 0V	-9 V to 14 V
Maximum differential voltage between terminals (with termination resistors enabled)	±6 V

<b>9</b>	<b>V, D, Not used, Not used</b>
<b>10</b>	<b>VI, DI, Not used, Not used</b>
<b>AB Servo (3), FD Servo(4), FR Servo (5), SC Servo (12)</b>	
Type	EIA-485 differential receivers
Maximum input frequency	512 kHz
Line loading	1 unit load
Line termination components	120 Ω (switchable)
Working common mode range	-7 V to +12 V
<b>SC SC (15)</b>	
Type	Differential voltage
Maximum Signal level	1.25 V peak to peak (sin with regard to sinref and cos with regard to cosref)
Maximum input frequency	See Table 4-10.
Maximum applied differential voltage and common mode voltage range	±4 V
<b>EnDat (8), SSI (10), BiSS (13)</b>	
Not used	
<b>Resolver (14)</b>	
Not used	
<b>Common to All</b>	
Absolute maximum applied voltage relative to 0V	-9 V to 14 V
Maximum differential voltage between terminals (with termination resistors enabled)	±6 V

<b>11</b>	<b>W, Clock, Not used, Not used</b>
<b>12</b>	<b>W, Clock, Not used, Not used</b>
<b>AB Servo (3), FD Servo(4), FR Servo (5), SC Servo (12)</b>	
Type	EIA-485 differential receivers
Maximum input frequency	512 kHz
Line loading	1 unit load
Line termination components	120 Ω (switchable)
Working common mode range	-7 V to +12 V
<b>SC EnDat (9), SC SSI (11)</b>	
Type	Differential voltage
Maximum Signal level	1.25 V peak to peak (sin with regard to sinref and cos with regard to cosref)
Maximum input frequency	See Table 4-10.
Maximum applied differential voltage and common mode voltage range	±4 V
<b>EnDat (8), SSI (10), BiSS (13)</b>	
Not used	
<b>Resolver (14)</b>	
Not used	
<b>Common to All</b>	
Absolute maximum applied voltage relative to 0V	-9 V to 14 V
Maximum differential voltage between terminals (with termination resistors enabled)	±6 V

**Common to all Feedback types**

<b>13</b>	<b>Feedback device supply</b>
Supply voltage	5.15 V ±2 %, 8 V ±5 % or 15 V ± 5 %
Maximum output current	300 mA for 5 V and 8 V 200 mA for 15 V
The voltage on Terminal 13 is controlled by Pr <b>03.036</b> . The default for this parameter is 5 V (0) but this can be set to 8 V (1) or 15 V (2). Setting the encoder voltage too high for the encoder could result in damage to the feedback device. The termination resistors should be disabled if the outputs from the encoder are higher than 5 V.	

<b>14</b>	<b>0V Common</b>
-----------	------------------

<b>15</b>	<b>Motor thermistor input</b>
Thermistor type is selected in <i>P1 Thermistor Type</i> ( <b>03.118</b> ).	

**Sincos encoder resolution**

The sine wave frequency can be up to 500 kHz but the resolution is reduced at high frequency. Table 4-10 shows the number of bits of interpolated information at different frequencies and with different voltage levels at the drive encoder port. The total resolution in bits per revolution is the ELPR plus the number of bits of interpolated information. Although it is possible to obtain 11 bits of interpolation information, the nominal design value is 10 bits.

**Table 4-10 Feedback resolution based on frequency and voltage level**

Volt/Freq	1 kHz	5 kHz	50 kHz	100 kHz	200 kHz	500 kHz
1.2	11	11	10	10	9	8
1.0	11	11	10	9	9	7
0.8	10	10	10	9	8	7
0.6	10	10	9	9	8	7
0.4	9	9	9	8	7	6

**4.6 Safe Torque Off (STO)**

The Safe Torque Off function provides a means for preventing the drive from generating torque in the motor, with a very high level of integrity. It is suitable for incorporation into a safety system for a machine. It is also suitable for use as a conventional drive enable input.

The safety function is active when the STO input is in the logic-low state as specified in the control terminal specification. The function is defined according to EN 61800-5-2 and IEC 61800-5-2 as follows. (In these standards a drive offering safety-related functions is referred to as a PDS(SR)):

*'Power that can cause rotation (or motion in the case of a linear motor) is not applied to the motor. The PDS(SR) will not provide energy to the motor which can generate torque (or force in the case of a linear motor)'*

This safety function corresponds to an uncontrolled stop in accordance with stop category 0 of IEC 60204-1.

The Safe Torque Off function makes use of the special property of an inverter drive with an induction motor, which is that torque cannot be generated without the continuous correct active behaviour of the inverter circuit. All credible faults in the inverter power circuit cause a loss of torque generation.

**Note on the use of servo motors, other permanent-magnet motors, reluctance motors and salient-pole induction motors:**

When the drive is disabled through Safe Torque Off, a possible (although highly unlikely) failure mode is for two power devices in the inverter circuit to conduct incorrectly.

This fault cannot produce a steady rotating torque in any AC motor. It produces no torque in a conventional induction motor with a cage rotor.

If the rotor has permanent magnets and/or saliency, then a transient alignment torque may occur. The motor may briefly try to rotate by up to 180° electrical, for a permanent magnet motor, or 90° electrical, for a salient pole induction motor or reluctance motor. This possible failure mode must be allowed for in the machine design.

The Safe Torque Off function is fail-safe, so when the Safe Torque Off input is disconnected the drive will not operate the motor, even if a combination of components within the drive has failed. Most component failures are revealed by the drive failing to operate. Safe Torque Off is also independent of the drive firmware. This meets the requirements of the following standards, for the prevention of operation of the motor.

## Machinery Applications

The Safe Torque Off function is suitable for use as a safety component of a machine:

### Safety Parameters

According to IEC 61508-1 to 7 / EN 61800-5-2 / EN 62061

Type	Value	Percentage of SIL 3 allowance
Proof test interval	20 years	
High demand or a continuous mode of operation		
PFH (1/h)	$4.21 \times 10^{-11}$ 1/h	<1 %
Low demand mode of operation (not EN 61800-5-2)		
PFDavg	$3.68 \times 10^{-6}$	< 1 %

According to EN ISO 13849-1

Type	Value	Classification
Category	4	
Performance Level (PL)	e	
MTTF <sub>D</sub> (STO1)	>2500 years	High
MTTF <sub>D</sub> (STO2)	>2500 years	High
MTTFD (Single channel STO)	>2500 years	High
DC <sub>avg</sub>	≥99 %	High
Mission time	20 years	

#### NOTE

Logic levels comply with IEC 61131-2:2007 for type 1 digital inputs rated at 24 V. Maximum level for logic low to achieve SIL3 and PL e 5 V and 0.5 mA.

### Two-channel Safe Torque Off

The Digitax HD M75X series has dual channel Safe Torque Off.

The dual channel STO has two fully independent channels.

Each input meets the requirements of the standards as defined above.

If either or both inputs are set at a logic low state, there are no single faults in the drive which can permit the motor to be driven.

It is not necessary to use both channels to meet the requirements of the standards. The purpose of the two channels is to allow connection to machine safety systems where two channels are required, and to facilitate protection against wiring faults.

For example, if each channel is connected to a safety-related digital output of a safety related controller, computer or PLC, then on detection of a fault in one output the drive can still be disabled safely through the other output.

Under these conditions, there are no single wiring faults which can cause a loss of the safety function, i.e. inadvertent enabling of the drive.

In the event that the two-channel operation is not required, the two inputs can be connected together to form a single Safe Torque Off input.

### One-channel Safe Torque Off (Including Two-channel Safe Torque off with the inputs connected together).

In a single channel Safe torque Off application there are no single faults in the drive which can permit the motor to be driven. Therefore it is not necessary to have a second channel to interrupt the power connection, nor a fault detection circuit.

It is important to note that a single short-circuit from the Safe Torque Off input to a DC supply of > 5V could cause the drive to be enabled.

This might occur through a fault in the wiring. This can be excluded according to EN ISO 13849-2 by the use of protected wiring. The wiring can be protected by either of the following methods:

- By placing the wiring in a segregated cable duct or other enclosure.
- or
- By providing the wiring with a grounded (0V of the Drive) shield in a positive-logic grounded control circuit. The shield is provided to avoid a hazard from an electrical fault. It may be grounded by any convenient method; no special EMC precautions are required.

### Note on response time of Safe Torque Off, and use with safety controllers with self-testing outputs:

Safe Torque Off has been designed to have a response time of greater than 1 ms so that it is compatible with safety controllers whose outputs are subject to a dynamic test with a pulse width not exceeding 1 ms.



WARNING

The design of safety-related control systems must only be done by personnel with the required training and experience. The Safe Torque Off function will only ensure the safety of a machine if it is correctly incorporated into a complete safety system. The system must be subject to a risk assessment to confirm that the residual risk of an unsafe event is at an acceptable level for the application.



WARNING

Safe Torque Off inhibits the operation of the drive, this includes inhibiting braking. If the drive is required to provide both braking and Safe Torque Off in the same operation (e.g. for emergency stop) then a safety timer relay or similar device must be used to ensure that the drive is disabled a suitable time after braking. The braking function in the drive is provided by an electronic circuit which is not fail-safe. If braking is a safety requirement, it must be supplemented by an independent fail-safe braking mechanism.



WARNING

Safe Torque Off does not provide electrical isolation. The supply to the drive must be disconnected by an approved isolation device before gaining access to power connections.



WARNING

It is essential to observe the maximum permitted voltage of 5 V for a safe low (disabled) state of Safe Torque Off. The connections to the drive must be arranged so that voltage drops in the 0 V wiring cannot exceed this value under any loading condition. It is strongly recommended that the Safe Torque Off circuit be provided with a dedicated 0 V conductor which should be connected to either terminals 1, 3, 4, 5, 7 or 15 at the drive.

### Safe Torque Off over-ride

The drive does not provide any facility to over-ride the Safe Torque Off function, for example for maintenance purposes.

### Lift (Elevator) Applications

The Safe Torque Off function is suitable for use as a safety component in lift (elevator) applications:

The Safe Torque Off function can be used to eliminate electromechanical contactors, including special safety contactors, which would otherwise be required for safety applications.

For further information, contact the supplier of the drive.

## 5 Getting started

This chapter introduces the user interfaces, menu structure and security levels of the drive.

### 5.1 Display and Keypad operation

The drive can be directly fitted with a KI-Compact Display.

Or

A Remote-Keypad RTC connected to the drive via a KI-Remote keypad adaptor.

#### 5.1.1 KI-Compact Display

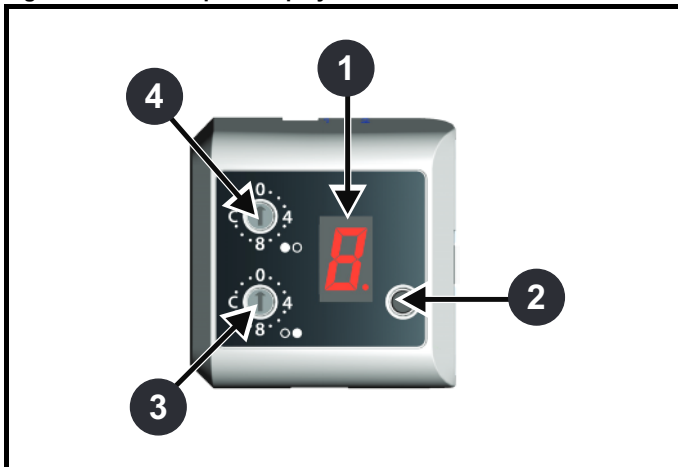
The M75X display provides the following features:

- Displays drive status information.
- Allows the drive to be identified with a unique IP address configured via dials on the front of the display.
- A push button to reset drive trips.

If not already fitted, the display can be ordered from the supplier of the drive. Refer to Table 2-3 *Display / Keypad identification* on page 14.

#### 5.1.2 Drive state representation

Figure 5-1 KI-Compact Display



1. Single Character display.
2. Reset switch.
3. Rotary dial for station alias setting (least significant).
4. Rotary dial for station alias setting (Most significant).

The display provides the following drive status information:

A single character code is used to indicate non tripped drive states as a non flashing display, refer to Table 5-1 for further information.

Table 5-1 Single character status indication codes (non tripped drive state)

Display character	Drive status LED	Description	Drive output stage
	Non flashing (RED)	Inhibit state	Disabled
	Flashing (RED)	Communications to drive lost for > 10 seconds	N/A
	Non flashing (RED)	Ready state	Disabled
	Non flashing (RED)	Under the following status indicators: Stop Scan Run Supply Loss Deceleration DC injection Position Active Heat Phasing	Enabled
	Non flashing (RED)	Under voltage	Disabled

The decimal point on the display is used to alert the user to either of two situations:

- The SD card is being accessed.  
The decimal point on the display will be illuminated constantly whenever the drive is accessing the SD card.
- The drive has an active alarm.  
The decimal point will flash if the drive has an active alarm.

#### 5.1.3 IP Address configuration

When a Digitax HD M750 is fitted with a KI-Compact Display the two rotary dials on the display allow the final octet (host component) of the IP address to be configured when set to a non zero value and a 24 bit subnet (255.255.255.0), see Table 5-2.

Table 5-2 Address components

Address class	IP Address	Subnet component	Host
C	w.x.y.z	w.x.y	z

The final octet of the IP address configured using the KI-Compact Display is an 8 bit value (decimal 1 to 255). The most significant nibble is set by adjusting the top dial and the least significant nibble is set by the bottom dial (see Figure 5-1 *KI-Compact Display*).

Dial settings and equivalent decimal values are shown in Table 5-3.

**Table 5-3 Dial settings and equivalent decimal value**

Most significant nibble		Least significant nibble	
Dial setting	Decimal value	Dial setting	Decimal value
1	16	1	1
2	32	2	2
3	48	3	3
4	64	4	4
5	80	5	5
6	96	6	6
7	112	7	7
8	128	8	8
9	144	9	9
A	160	A	10
B	176	B	11
C	192	C	12
D	208	D	13
E	224	E	14
F	240	F	15

The final octet of the IP address will be set to the sum of the most significant nibble and the least significant nibble (in decimal).

As the dials are adjusted each setting is shown on the display. Once the dials are set to the desired configurations the display will confirm the dial settings in hexadecimal followed by the final octet of the IP address in decimal, dial settings and IP address settings are separated with a hyphen (-).

Once the desired dial configurations have been set, the KI-Compact Display will transfer the value to Pr **11.017 Keypad defined node address** and if the value is not zero Pr **3.00.010 Active IP Address** is updated with the chosen address.

The drive will use Pr **3.00.006 IP Address** as the source for the IP address when the dial setting is a zero value. Any non zero rotary dial setting will result in Pr **3.00.006 IP Address** being ignored and Pr **3.00.010 Active IP Address** becoming the chosen address.

**Example:**

To set a node address of 55 via the display, with reference to Table 5-3, set the most significant dial to 3 (decimal 48) and the least significant dial to 7 (decimal 7).

**NOTE**

The IP address setting can be configured from the rotary dials of the KI-Compact Display with no power applied to the drive (with the exception of a zero value setting). Non zero configured settings will be transferred to the drive on the next power up.

**NOTE**

The KI-Compact Display can be installed/removed while the drive is powered. A delay of 10 seconds should be maintained following power up or following a node address dial adjustment before the KI-Compact Display can be removed from the drive, to ensure correct transfer of IP address configuration data.

**NOTE**

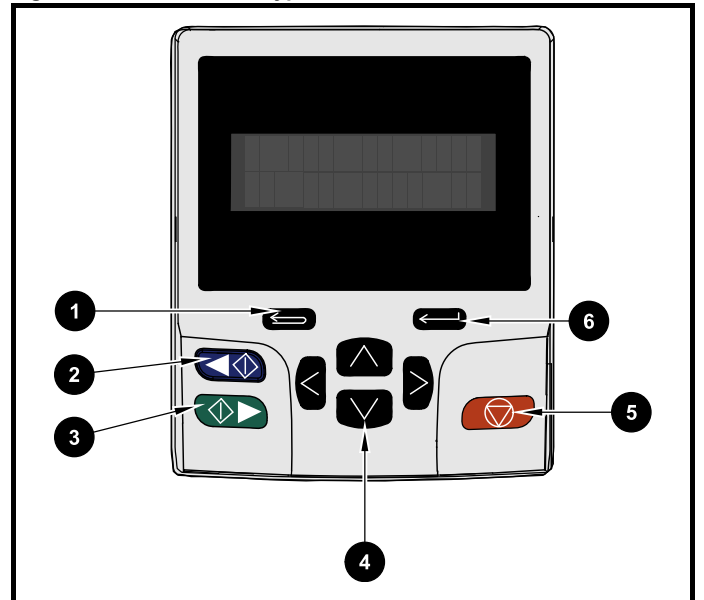
The rotary dials have no effect when the Profinet interface is enabled (Pr **3.02.018** = ProfiNet).

**5.1.4 KI-Remote Keypad RTC**

The KI-Remote Keypad RTC display consists of two rows of text. The upper row shows the drive status or the menu and parameter number currently being viewed. The lower row of the display line shows the parameter value or the specific trip type. The last two characters on the first row may display special indications. If more than one of these indications is active then the indications are prioritized as shown in Table 5-5.


When the drive is powered up the lower row will show the power up parameter defined by *Parameter Displayed At Power-Up* (11.022).

**Figure 5-2 KI-Remote Keypad RTC**



1. Escape button
2. Start reverse (Auxiliary button)
3. Start forward
4. Navigation keys (x4)
5. Stop / Reset (red) button
6. Enter button

**NOTE**



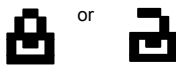




The red stop  button is also used to reset the drive.

The parameter value is correctly displayed in the lower row of the keypad display, see table below.

**Table 5-4 Keypad display formats**

Display formats	Value
IP Address	127.000.000.000
MAC Address	01ABCDEF2345
Time	12:34:56
Date	31-12-11 or 12-31-11
Version number	01.02.02.00
Character	ABCD
32 bit number with decimal point	21474836.47
16 bit binary number	0100001011100101
Text	M600
Number	1.5 Hz

**Table 5-5 Active action icon**

Active action icon	Description	Row (1=top)	Priority in row
	Accessing non-volatile media card	1	1
	Alarm active	1	2
	Keypad real-time clock battery low	1	3
	Drive security active and locked or unlocked	1	4
	Motor map 2 active	2	1
	User program running	3	1
	Keypad reference active	4	1
	No entry - read only parameter cannot be edited	1	1

## 5.2 KI-Remote Keypad operation

### 5.2.1 Control buttons

The keypad consists of:

- Navigation Keys - Used to navigate the parameter structure and change parameter values.
- Enter / Mode button - Used to toggle between parameter edit and view mode.
- Escape / Exit button - Used to exit from parameter edit or view mode. In parameter edit mode, if parameter values are edited and the exit button pressed the parameter value will be restored to the value it had on entry to edit mode.
- Start forward button - Use to provide a 'Run' command if keypad mode is selected.
- Start reverse button - Used to control the drive if keypad mode is selected and the reverse button is activated. If *Enable Auxiliary Key* (06.013) = 1, then the keypad reference is toggled between run forward and run reverse each time the button is pressed. If *Enable Auxiliary Key* (06.013) = 2, then the button functions as a run reverse key.
- Stop / Reset button - Used to reset the drive. In keypad mode can be used for 'Stop'.

#### NOTE


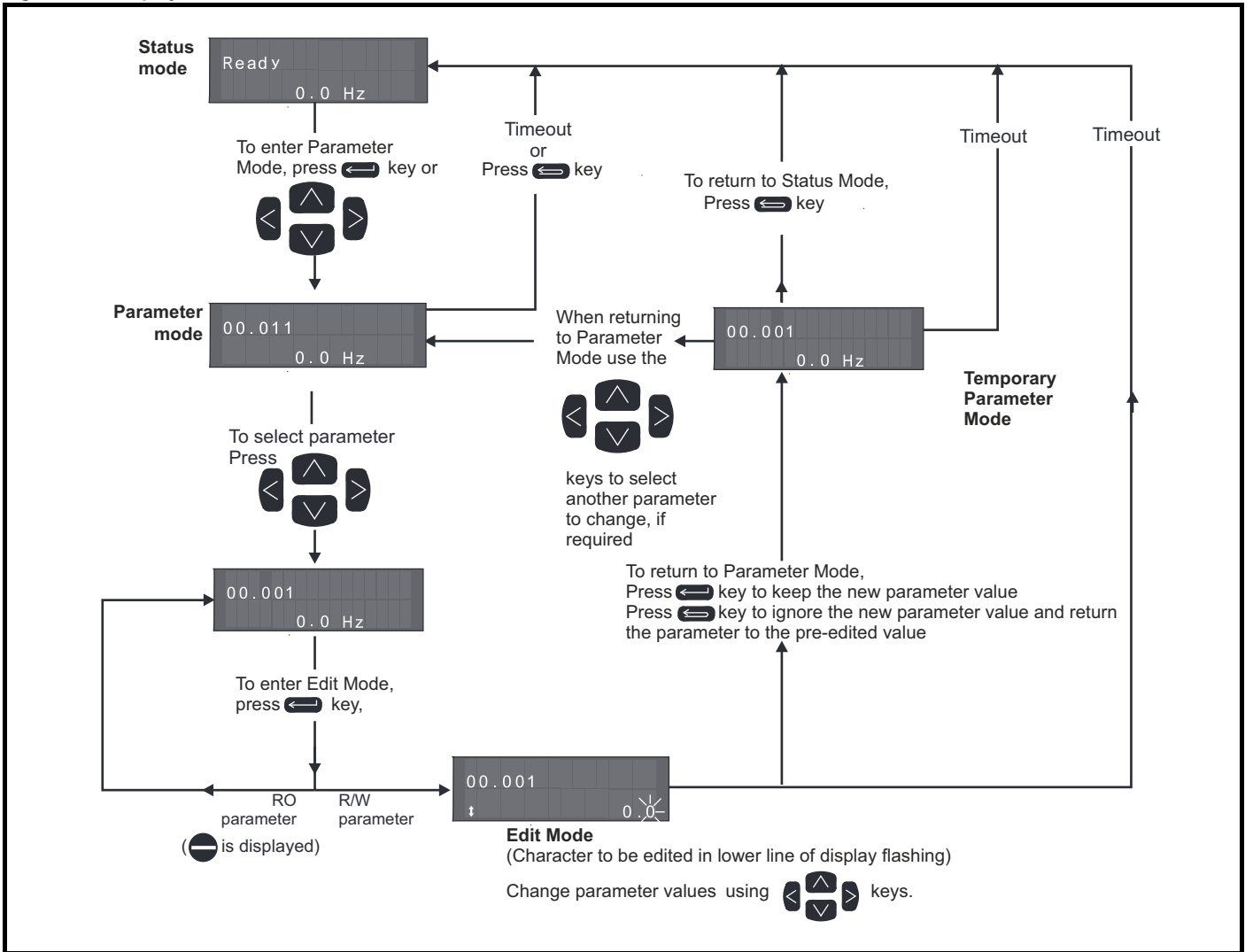
Low battery voltage is indicated by  low battery symbol on the keypad display.

Figure 5-3 overleaf shows an example on moving between menus and editing parameters.

**Figure 5-3 Display modes**



**NOTE**

The navigation keys can only be used to move between menus if Pr **00.049** has been set to show 'All Menus'. Refer to section 5.9 *Parameter access level and security* on page 38.

**5.2.2 Quick access mode**

The quick access mode allows direct access to any parameter without scrolling through menus and parameters.

To enter the quick access mode, press and hold the Enter button on the keypad while in 'parameter mode'.

**Figure 5-4 Quick access mode**



**5.2.3 KI-Remote Keypad shortcuts**

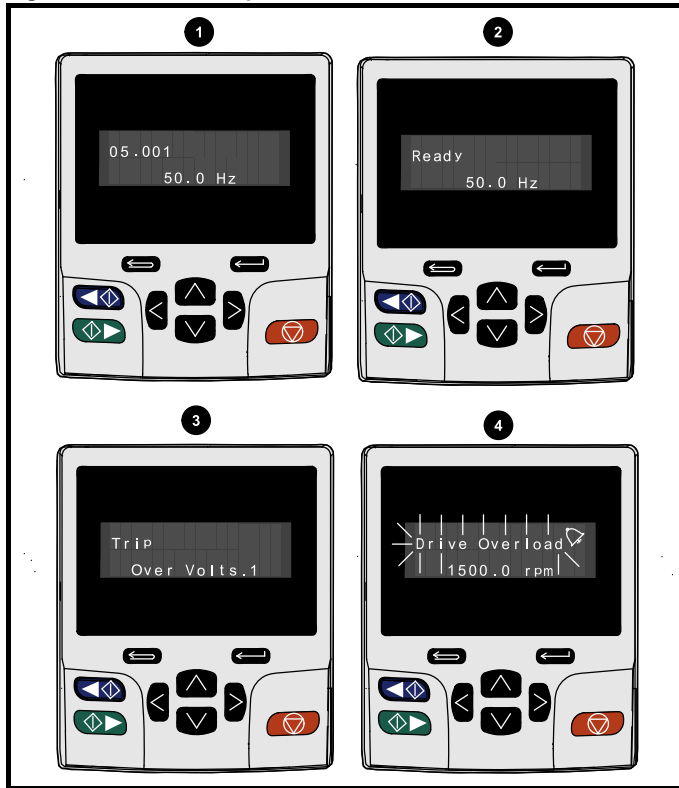
**In 'parameter mode':**

- If the up and down keypad buttons are pressed together, then the keypad display will jump to the start of the parameter menu being viewed, i.e. Pr **05.005** being viewed, when the above buttons pressed together will jump to Pr **05.000**.
- If the left and right keypad buttons are pressed together, then the keypad display will jump to the last viewed parameter in Menu 0.

**In 'parameter edit mode':**

- If the up and down keypad buttons are pressed together, then the parameter value of the parameter being edited will be set to 0.
- If the left and right keypad buttons are pressed together, the least significant digit (furthest right) will be selected on the keypad display for editing.

**Figure 5-5 Mode examples**



- 1. Parameter view mode: Read write or Read only**
- 2. Status mode: Drive OK status**  
If the drive is ok and the parameters are not being edited or viewed, the upper row of the display will show one of the following:
  - 'Inhibit', 'Ready' or 'Run'.
- 3. Status mode: Trip status**  
When the drive is in trip condition, the upper row of the display will indicate that the drive has tripped and the lower row of the display will show the trip code. For further information regarding trip codes. refer to Table 13-4 *Trip indications* on page 220.

- 4. Status mode: Alarm status**  
During an 'alarm' condition the upper row of the display flashes between the drive status (Inhibit, Ready or Run, depending on what is displayed) and the alarm.



Do not change parameter values without careful consideration; incorrect values may cause damage or a safety hazard.

**NOTE**

When changing the values of parameters, make a note of the new values in case they need to be entered again.

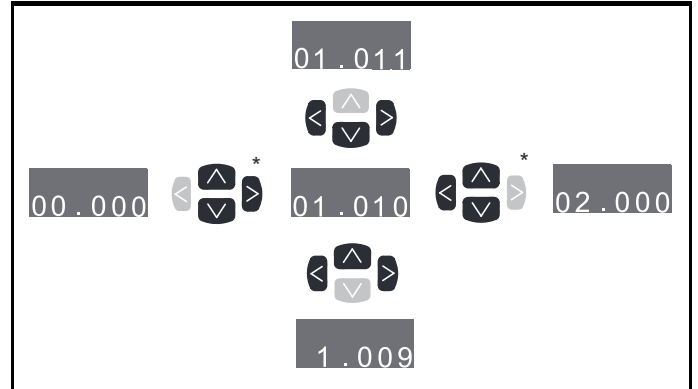
**NOTE**

For new parameter-values to apply after the line power supply to the drive is interrupted, new values must be saved. Refer to section 5.7 *KI-Remote Keypad saving parameters* on page 38.

## 5.3 Menu structure

The drive parameter structure consists of menus and parameters. The drive initially powers up so that only Menu 0 can be viewed. The up and down arrow buttons are used to navigate between parameters and once Pr **00.049** has been set to 'All Menus' the left and right buttons are used to navigate between menus. For further information, refer to section 5.9 *Parameter access level and security* on page 38.

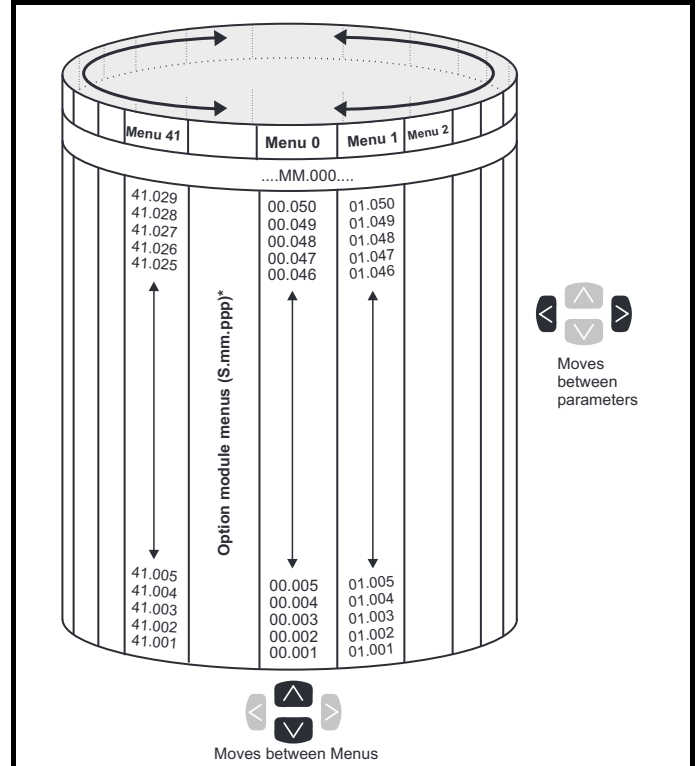
**Figure 5-6 Parameter navigation**



\* Can only be used to move between menus if all menus have been enabled (Pr **00.049**). Refer to section 5.9 *Parameter access level and security* on page 38.

The menus and parameters roll over in both directions. i.e. if the last parameter is displayed, a further press will cause the display to rollover and show the first parameter. When changing between menus the drive remembers which parameter was last viewed in a particular menu and thus displays that parameter.

**Figure 5-7 Menu structure**



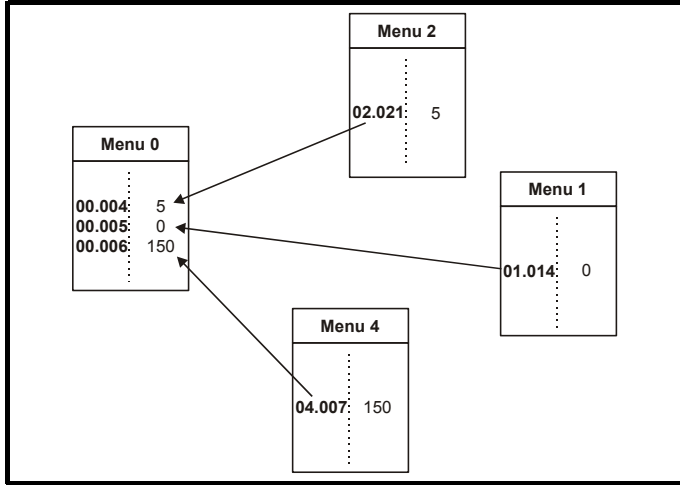
\* The option module menus (S.mm.ppp) are only displayed if option modules are installed. Where S signifies the option module slot number and the mm.ppp signifies the menu and the parameter number of the option module's internal menus and parameter.

## 5.4 Menu 0

Menu 0 is used to bring together various commonly used parameters for basic easy set up of the drive. The parameters displayed in Menu 0 can be configured in Menu 22. Appropriate parameters are copied from the advanced menus into Menu 0 and thus exist in both locations.

For further information, refer to Chapter 6 *Basic parameters* on page 41.

**Figure 5-8 Menu 0 copying**



## 5.5 Advanced menus

The advanced menus consist of groups or parameters appropriate to a specific function or feature of the drive. Menus 0 to 41 can be viewed on the Remote Keypad RTC.


The option module menus (S.mm.ppp) are only displayed if option modules are installed. Where S signifies the option module slot number and the mm.ppp signifies the menu and parameter number of the option module's internal menus and parameter.




**Table 5-6 Advanced menu descriptions**

Menu	Description
0	Commonly used basic set up parameters for quick / easy programming
1	Frequency / Speed reference
2	Ramps
3	Frequency slaving, speed feedback and speed control
4	Torque and current control
5	Motor control
6	Sequencer and clock
7	Analog I/O
8	Digital I/O
9	Programmable logic, motorized pot, binary sum, timers and scope
10	Status and trips
11	Drive set-up and identification, serial communications
12	Threshold detectors and variable selectors
13	Standard motion control
14	User PID controller
15	Option module slot 1 set-up menu
16	Option module slot 2 set-up menu
17	Option module slot 3 set-up menu
18	General option module application menu 1
19	General option module application menu 2
20	General option module application menu 3
21	Second motor parameters
22	Menu 0 set-up
23	Not allocated
25	Option module slot 1 application parameters
26	Option module slot 2 application parameters
27	Option module slot 3 application parameters
29	Reserved menu
30	Onboard user programming application menu
31-41	Advanced motion controller set-up parameters
Slot 1	Slot 1 option menus**
Slot 2	Slot 2 option menus**
Slot 3	Slot 3 option menus**

\* Only displayed when the option modules are installed.

### 5.5.1 KI-Remote Keypad set-up menu

To enter the keypad set-up menu press and hold the escape  button on the keypad from status mode. All the keypad parameters are saved to the keypad non-volatile memory when exiting from the keypad set-up menu.

To exit from the keypad set-up menu press the escape  or  or  button. Below are the keypad set-up parameters.

**Table 5-7 KI-Remote Keypad RTC set-up parameters**

Parameters		Range	Type
Keypad.00	Language*	Classic English (0) English (1) German (2) French (3) Italian (4) Spanish (5) Chinese (6)	RW
Keypad.01	Show Units	Off (0), On (1)	RW
Keypad.02	Backlight Level	0 to 100 %	RW
Keypad.03	Keypad Date	01.01.10 to 31.12.99	RO
Keypad.04	Keypad Time	00:00:00 to 23:59:59	RO
Keypad.05	Show Raw Text Parameter Values	Off (0), On (1)	RW
Keypad.06	Software Version	00.00.00.00 to 99.99.99.99	RO
Keypad. 07	Language version	00.00.00.00 to 99.99.99.99	RO
Keypad. 08	Font version	0 to 1000	RO
Keypad. 09	Show menu names	Off or on	RW

**NOTE**

It is not possible to access the keypad parameters via any communications channel.

**5.5.2 KI-Remote Keypad alarm indications**

An alarm is an indication given on the display by alternating the alarm string with the drive status string on the upper row and showing the alarm symbol in the last character in the upper row. Alarms strings are not displayed when a parameter is being edited, but the user will still see the alarm character on the upper row.

**Table 5-8 Alarm indications**

Alarm string	Description
<b>Brake Resistor</b>	Brake resistor overload. <i>Braking Resistor Thermal Accumulator</i> (10.039) in the drive has reached 75.0 % of the value at which the drive will trip.
<b>Motor Overload</b>	<i>Motor Protection Accumulator</i> (04.019) in the drive has reached 75.0 % of the value at which the drive will trip and the load on the drive is > 100 %.
<b>Ind Overload</b>	Regen inductor overload. <i>Inductor Protection Accumulator</i> (04.019) in the drive has reached 75.0 % of the value at which the drive will trip and the load on the drive is > 100 %.
<b>Drive Overload</b>	Drive over temperature. <i>Percentage Of Drive Thermal Trip Level</i> (07.036) in the drive is greater than 90 %.
<b>Auto Tune</b>	The autotune procedure has been initialized and an autotune in progress.
<b>Limit Switch</b>	Limit switch active. Indicates that a limit switch is active and that is causing the motor to be stopped.

**5.5.3 KI-Remote Keypad display messages**

The following tables indicate the various possible mnemonics which can be displayed by the drive and their meaning.

**Table 5-9 Status indications**

Upper row string	Description	Drive output stage
<b>Inhibit</b>	The drive is inhibited and cannot be run. The Safe Torque Off signal is not applied to Safe Torque Off terminals or Pr <b>06.015</b> is set to 0. The other conditions that can prevent the drive from enabling are shown as bits in <i>Enable Conditions</i> (06.010).	Disabled
<b>Ready</b>	The drive is ready to run. The drive enable is active, but the drive inverter is not active because the final drive run is not active.	Disabled
<b>Stop</b>	The drive is stopped / holding zero speed.	Enabled
<b>Run</b>	The drive is active and running.	Enabled
<b>Scan</b>	The drive is enabled in Regen mode and is trying to synchronize to the supply.	Enabled
<b>Supply Loss</b>	Supply loss condition has been detected.	Enabled
<b>Deceleration</b>	The motor is being decelerated to zero speed / frequency because the final drive run has been deactivated.	Enabled
<b>dc injection</b>	The drive is applying dc injection braking.	Enabled
<b>Position</b>	Positioning / position control is active during an orientation stop.	Enabled
<b>Trip</b>	The drive has tripped and no longer controlling the motor. The trip code appears in the lower display.	Disabled
<b>Active</b>	The Regen unit is enabled and synchronized to the supply.	Enabled
<b>Under Voltage</b>	The drive is in the under voltage state either in low voltage or high voltage mode.	Disabled
<b>Heat</b>	The motor pre-heat function is active.	Enabled
<b>Phasing</b>	The drive is performing a 'phasing test on enable'.	Enabled

**Table 5-10 Option module and SD card and other status indications at power-up**

First row string	Second row string	Status
Booting	Parameters	Parameters are being loaded
Drive parameters are being loaded from an SD Card.		
Booting	User Program	User program being loaded
User program is being loaded from an SD Card to the drive.		
Booting	Option Program	User program being loaded
User program is being loaded from an SD Card to the option module in slot X.		
Writing To	NV Card	Data being written to SD Card
Data is being written to an SD Card to ensure that its copy of the drive parameters is correct because the drive is in Auto or Boot mode.		
Waiting For	Power System	Waiting for power stage
The drive is waiting for the processor in the power stage to respond after power-up.		
Waiting For	Options	Waiting for an option module
The drive is waiting for the options modules to respond after power-up.		
Uploading From	Options	Loading parameter database
At power-up it may be necessary to update the parameter database held by the drive because an option module has changed or because an applications module has requested changes to the parameter structure. This may involve data transfer between the drive an option modules. During this period 'Uploading From Options' is displayed.		

## 5.6 KI-Remote Keypad changing the operating mode

Changing the operating mode returns all parameters to their default value, including the motor parameters. *User security status* (00.049) and *User security code* (00.034) are not affected by this procedure).

### Procedure

Use the following procedure only if a different operating mode is required:

1. Ensure the drive is not enabled, i.e. terminals 2 and 6 are open or Pr **06.015** is Off (0)
2. Enter either of the following values in Pr **mm.000**, as appropriate:  
1253 (50 Hz AC supply frequency)  
1254 (60 Hz AC supply frequency)
3. Change the setting of Pr **0.048** as follows:

Pr 00.048 setting		Operating mode
	1	Open-loop
	2	RFC-A
	3	RFC-S

The figures in the second column apply when serial communications are used.

4. Either:

- Press the red reset button
- Toggle the reset digital input
- Carry out a drive reset through serial communications by setting Pr **10.038** to 100.

### NOTE

Entering 1253 or 1254 in Pr **mm.000** will only load defaults if the setting of Pr **00.048** has been changed.

## 5.7 KI-Remote Keypad saving parameters

When changing a parameter in Menu 0, the new value is saved when pressing the Enter button to return to parameter view mode from parameter edit mode.

If parameters have been changed in the advanced menus, then the change will not be saved automatically. A save function must be carried out.

### Procedure

1. Select 'Save Parameters' in Pr **mm.000** (alternatively enter a value of 1001 in Pr **mm.000**)
2. Either:
  - Press the red reset button
  - Toggle the reset digital input, or
  - Carry out a drive reset through serial communications by setting Pr **10.038** to 100

## 5.8 Restoring parameter defaults

Restoring parameter defaults by this method saves the default values in the drives memory. *User security status* (00.049) and *User security code* (00.034) are not affected by this procedure).

### Procedure

1. Ensure the drive is not enabled, i.e. terminal 2 & 6 are open or Pr **06.015** is Off (0)
2. Select 'Reset 50 Hz Defs' or 'Reset 60 Hz Defs' in Pr **mm.000**. (alternatively, enter 1233 (50 Hz settings) or 1244 (60 Hz settings) in Pr **mm.000**).
3. Either:
  - Press the red reset button on the KI-Compact Display or KI-Remote Keypad.
  - Toggle the reset digital input.
  - Carry out a drive reset through serial communications by setting Pr **10.038** to 100

## 5.9 Parameter access level and security

The parameter access level determines whether the user has access to Menu 0 only or to all the advanced menus (Menus 1 to 41) in addition to Menu 0.

The User Security determines whether the access to the user is read only or read write.

Both the User Security and Parameter Access Level can operate independently of each other as shown in Table 5-11.

**Table 5-11 Parameter access level and security**

User security status (11.044)	Access level	User security	Menu 0 status	Advanced menu status
0	Menu 0	Open	RW	Not visible
		Closed	RO	Not visible
1	All Menus	Open	RW	RW
		Closed	RO	RO
2	Read-only Menu 0	Open	RO	Not visible
		Closed	RO	Not visible
3	Read-only	Open	RO	RO
		Closed	RO	RO
4	Status only	Open	Not visible	Not visible
		Closed	Not visible	Not visible
5	No access	Open	RW	Not visible
		Closed	Not visible	Not visible

The default settings of the drive are Parameter Access Level Menu 0 and user Security Open i.e. read / write access to Menu 0 with the advanced menus not visible.

### 5.9.1 User Security Level / Access Level

The drive provides a number of different levels of security that can be set by the user via *User Security Status* (11.044); these are shown below.

User Security Status (Pr 11.044)	Description
Menu 0 (0)	All writable parameters are available to be edited but only parameters in Menu 0 are visible.
All menus (1)	All parameters are visible and all writable parameters are available to be edited.
Read-only Menu 0 (2)	Access is limited to Menu 0 parameters only. All parameters are read-only.
Read-only (3)	All parameters are read-only however all menus and parameters are visible.
Status only (4)	The keypad remains in status mode and no parameters can be viewed or edited.
No access (5)	The keypad remains in status mode and no parameters can be viewed or edited. Drive parameters cannot be accessed via a comms/ fieldbus interface in the drive or any option module.

### 5.9.2 Changing the User Security Level / Access Level


The security level is determined by the setting of Pr **00.049** or Pr **11.044**. The Security Level can be changed through the KI-Remote Keypad even if the User Security Code has been set.


### 5.9.3 User Security Code

The User Security Code, when set, prevents write access to any of the parameters in any menu.



#### Setting User Security Code

Enter a value between 1 and 2147483647 in Pr **00.034** and press the

 button; the security code has now been set to this value. In order to activate the security, the Security level must be set to desired level in Pr **00.049**. When the drive is reset, the security code will have been


activated and the drive returns to Menu 0 and the  symbol is displayed in the right hand corner of the keypad display. The value of Pr **00.034** will return to 0 in order to hide the security code.

### Unlocking User Security Code

Select a parameter that need to be edited and press the  button, the upper display will now show 'Security Code'. Use the arrow buttons to set the security code and press the  button. With the correct security code entered, the display will revert to the parameter selected in edit mode.

If an incorrect security code is entered, the following message 'Incorrect security code' is displayed, then the display will revert to parameter view mode.

### Disabling User Security

Unlock the previously set security code as detailed above. Set Pr **00.034** to 0 and press the  button. The User Security has now been disabled, and will not have to be unlocked each time the drive is powered up to allow read / write access to the parameters.

## 5.10 Displaying parameters with non-default values only

By selecting 'Show non-default' in Pr **mm.000** (Alternatively, enter 12000 in Pr **mm.000**), the only parameters that will be visible to the user will be those containing a non-default value. This function does not require a drive reset to become active. In order to deactivate this function, return to Pr **mm.000** and select 'No action' (alternatively enter a value of 0). Please note that this function can be affected by the access level enabled, refer to section 5.9 *Parameter access level and security* on page 38 for further information regarding access level.

## 5.11 Displaying destination parameters only

By selecting 'Destinations' in Pr **mm.000** (Alternatively enter 12001 in Pr **mm.000**), the only parameters that will be visible to the user will be destination parameters. This function does not require a drive reset to become active. In order to deactivate this function, return to Pr **mm.000** and select 'No action' (alternatively enter a value of 0).

Please note that this function can be affected by the access level enabled, refer to section 5.9 *Parameter access level and security* on page 38 for further information regarding access level.

## 5.12 Communications

The Digitax HD M750 drives offer Ethernet fieldbus Communications. This enables the drive set-up, operation and monitoring to be carried out with a PC or controller if required.

### 5.12.1 Digitax M750 - Ethernet communications

The drive offers fieldbus communications via Ethernet, this enables the drive set-up, operation and monitoring to be carried out with a PC or controller. The drive provides two RJ45 connections with an Ethernet switch for easy network creation. The Ethernet option provides support for the following protocols:

- Modbus TCP
- EtherNet/IP or Profinet IO
- Web pages\*
- Email\*\*
- Synchronization with IEEE1588
- RTMoE

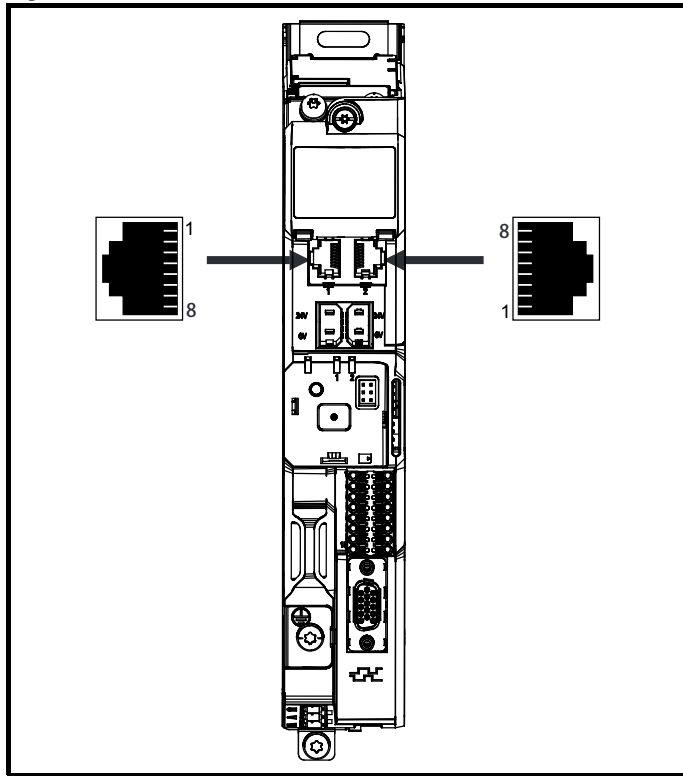
\*Basic Web page functionality only

\*\*Features have not been implemented but will be available soon.

In addition to two RJ45 connectors, each port provides a status LED for diagnostic / information purposes.

LED status	Description
Off	Ethernet connection not detected
Solid green	Ethernet connection detected but no data
Flashing green	Ethernet connection detected and data flow

**Figure 5-9 Location of the comms connectors**



**NOTE**

The shell of the RJ45 connector is isolated from the 0V of the drive control terminals but it is connected to ground.

**NOTE**

Modbus TCP/IP has a maximum number of 4 client connections. Refer to Pr 3.15.006 (Maximum Connections) in the *Parameter Reference Guide*. The default value of Pr 3.15.006 is 2 client connections, but the maximum number of client connections is 10.

**Recommended cable**

It is recommended that a minimum specification of CAT5e is used in new installations. If the existing cabling is used this may limit the maximum data rate depending on the cable ratings. In noisy environments the use of STP cable will offer additional noise immunity.

**Maximum network lengths**

The main restriction imposed on the Ethernet cabling is the length of a single segment of the cable, for Copper - UTP/STP CAT 5 cable type, maximum trunk cable length should be limited to 100 m. If distances greater than this are required it may be possible to extend the network with additional switches.

**Ethernet set-up parameters**

This section covers the parameters necessary to establish an Ethernet connection to the drive.

**Table 5-12 Key to parameter table coding**

RW	Read / Write	ND	No default value
RO	Read only	NC	Not copied
Num	Number parameter	PT	Protected parameter
Bit	Bit parameter	RA	Rating dependant
Txt	Text string	US	User save
Bin	Binary parameter	PS	Power-down save
Fl	Filtered	DE	Destination
IP	IP Address	Mac	Mac Address
Date	Date parameter	Time	Time parameter
Chr	Character parameter		

<b>3.00.007 {17.007} Reset</b>	
RW	Bit
↕	Off (0) or On (1)
⇒	Off (0)

Changes to the Ethernet set-up parameters will not take effect until a *Reset* (3.00.007) has been performed.

<b>3.00.010 {17.010} Active IP Address</b>	
RO	IP
↕	000.000.000.000 to 255.255.255.255
⇒	

This parameter displays the Active IP Address.

<b>3.02.005 DHCP Enable</b>	
RW	Bit
↕	Off (0) or On (1)
⇒	On (1)

If *DHCP Enable* (3.02.005) is set to On (1), the IP address is acquired from the DHCP server and written to *IP Address* (3.02.006).

**NOTE**

When using manual / static IP address configuration, ensure *Subnet Mask* (3.02.007) and *Default Gateway* (3.02.008) should also be set manually.

**NOTE**

If *Protocol Mode Select* (3.02.018) is set to Profinet (2) and the IP address is assigned to a Profinet Controller, *DHCP Enable* (3.02.005) will be ignored and set to Off (0) on initialisation.

<b>3.02.006 IP Address</b>	
RW	IP
↕	000.000.000.000 to 255.255.255.255
⇒	192.168.001.100

This parameter controls and displays the IP address of the drive. If *DHCP Enable* (3.02.005) is set to On (1) this parameter will become read-only.

<b>3.02.007 Subnet Mask</b>	
RW	IP
↕	000.000.000.000 to 255.255.255.255
⇒	255.255.255.000

This parameter controls and displays the *Subnet Mask* (3.02.007) of the drive.

<b>3.02.008 Default Gateway</b>	
RW	IP
↕	000.000.000.000 to 255.255.255.255
⇒	192.168.1.254

This parameter controls and displays the *Default Gateway* (3.02.008) of the drive.

**PC Tools support**

The discovery protocol feature, which is supported by the Digitax HD PC tools, is able to discover the drives that are connected to a PC, independent of above parameter settings.

## 6 Basic parameters

Menu 0 is used to bring together various commonly used parameters for basic easy set up of the drive. All the parameters in Menu 0 appear in other menus in the drive (denoted by {...}). Menus 22 can be used to configure the parameters in Menu 0.

### 6.1 Parameter ranges and variable minimum / maximums

Some parameters in the drive have a variable range with a variable minimum and a variable maximum value which is dependent on one of the following:

- The settings of other parameters
- The drive rating
- The drive mode
- Combination of any of the above

For more information, refer to section 12.1 *Parameter ranges and Variable minimum/maximums* on page 126.

### 6.2 Menu 0: Basic parameters

Parameter	Range			Default			Type									
	OL	RFC-A	RFC-S	OL	RFC-A	RFC-S										
00.001	Minimum Reference Clamp	{01.007}	VM_NEGATIVE_REF_CLAMP1 Hz / rpm			0.0 Hz	0.0 rpm			RW	Num				US	
00.002	Maximum Reference Clamp	{01.006}	VM_POSITIVE_REF_CLAMP1 Hz / rpm			50 Hz default: 50.0 Hz 60 Hz default: 60.0 Hz	50 Hz default: 1500.0 rpm 60 Hz default: 1800.0 rpm	3000.0 rpm			RW	Num				US
00.003	Acceleration Rate 1	{02.011}	0.0 to VM_ACCEL_RATE s/100 Hz	0.000 to VM_ACCEL_RATE s/1000 rpm		5.0 s/100 Hz	2.000 s/1000 rpm	0.200 s/1000 rpm			RW	Num				US
00.004	Deceleration Rate 1	{02.021}	0.0 to VM_ACCEL_RATE s/100 Hz	0.000 to VM_ACCEL_RATE s/1000 rpm		10.0 s/100 Hz	2.000 s/1000 rpm	0.200 s/1000 rpm			RW	Num				US
00.005	Reference Selector	{01.014}	A1 A2 (0), A1 Preset (1), A2 Preset (2), Preset (3), Keypad (4), Precision (5), Keypad Ref (6)			A1 Preset (1)			RW	Txt						US
00.006	Symmetrical Current Limit	{04.007}	0.0 to VM_MOTOR1_CURRENT_LIMIT %			165.0 %	250 %			RW	Num		RA			US
00.007	Open-loop Control Mode	{05.014}	Ur S (0), Ur I (1), Fixed (2), Ur Auto (3), Ur I (4), Square (5)			Ur I (4)			RW	Txt						US
	Speed Controller Proportional Gain Kp1	{03.010}	0.0000 to 200.000 s/rad			0.0300 s/rad			0.0100 s/rad	RW	Num					US
00.008	Low Frequency Voltage Boost	{05.015}	0.0 to 25.0 %			1 %			RW	Num						US
	Speed Controller Integral Gain Ki1	{03.011}	0.00 to 655.35 s <sup>2</sup> /rad			0.10 s <sup>2</sup> /rad			1.00 s <sup>2</sup> /rad	RW	Num					US
00.009	Dynamic V to F Select	{05.013}	Off (0) or On (1)			Off (0)			RW	Bit						US
	Speed Controller Differential Feedback Gain Kd 1	{03.012}	0.00000 to 0.65535 1/rad			0.00000 1/rad			RW	Num						US
00.010	Motor Rpm	{05.004}	±180000 rpm						RO	Bit						US
	Speed Feedback	{03.002}	VM_SPEED rpm						RO	Num	ND	NC	PT	FI		
00.011	Output Frequency	{05.001}	VM_SPEED_FREQ_REF Hz	± 2000.0 Hz					RO	Num	ND	NC	PT	FI		
	P1 Position	{03.029}	0 to 65535						RO	Num	ND	NC	PT	FI		
00.012	Current Magnitude	{04.001}	0.000 to VM_DRIVE_CURRENT_UNIPOLAR A						RO	Bit	ND	NC	PT	FI		
00.013	Torque Producing Current	{04.002}	VM_DRIVE_CURRENT A						RO	Bit	ND	NC	PT	FI		
00.014	Torque Mode Selector	{04.011}	0 or 1	0 to 5		0			RW	Num						US
00.015	Ramp Mode	{02.004}	Fast (0), Standard (1), Std boost (2)	Fast (0), Standard (1)		Standard (1)	Fast (0)			RW	Txt					US
00.016	Ramp Enable	{02.002}	Off (0) or On (1)			On (1)			RW	Bit						US
00.017	Current Reference Filter 1 Time Constant	{04.012}	0.0 to 25.0 ms			0.0 ms			RW	Num						US
00.018	P1 Thermistor Fault Detection	{03.123}	None (0), Temperature (1), Temp or Short (2)			None (0)		Temperature (1)	RW	Txt						US
00.022	Bipolar Reference Enable	{01.010}	Off (0) or On (1)			Off (0)	On (1)			RW	Bit					US
00.023	Jog Reference	{01.005}	0.0 to 400.0 Hz	0.0 to 4000.0 rpm		0.0			RW	Num						US
00.024	Preset Reference 1	{01.021}	VM_SPEED_FREQ_REF			0.0			RW	Num						US
00.025	Preset Reference 2	{01.022}	VM_SPEED_FREQ_REF			0.0			RW	Num						US
00.026	Preset Reference 3	{01.023}	VM_SPEED_FREQ_REF Hz			0.0				RW	Num					US
	Overspeed Threshold	{03.008}	0 to 40000 rpm			0.0			RW	Num						US
00.027	Preset Reference 4	{01.024}	VM_SPEED_FREQ_REF Hz			0.0				RW	Num					US
	P1 Rotary Lines Per Revolution	{03.034}	1 to 100000			1024			4096	RW	Num					US
00.028	Enable Auxiliary Key	{06.013}	Disabled (0), Forward/Reverse (1), Run Reverse (2)			Disabled (0)			RW	Txt						US
00.029	NV Media Card File Previously Loaded	{11.036}	0 to 999						RO	Num		NC	PT			

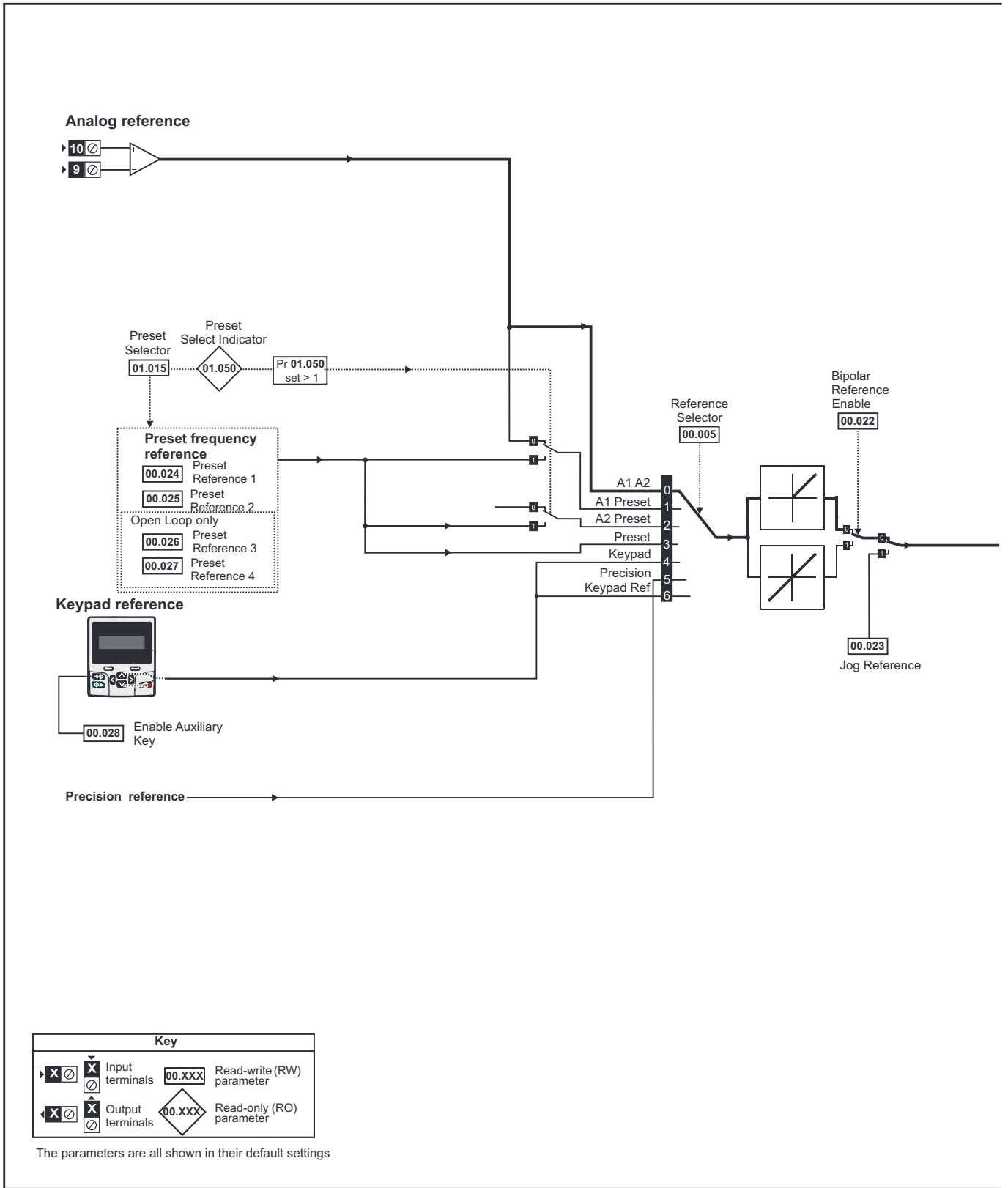
Parameter	Range			Default			Type						
	OL	RFC-A	RFC-S	OL	RFC-A	RFC-S							
00.030	Parameter Cloning	{11.042}	None (0), Read (1), Program (2), Auto (3), Boot (4)			None (0)			RW	Txt		NC	US
00.031	Drive Rated Voltage	{11.033}	200 V (0), 400 V (1)						RO	Txt	ND	NC	PT
00.032	Maximum Heavy Duty Rating	{11.032}	0.000 to 99999.999 A						RO	Num	ND	NC	PT
00.033	Catch A Spinning Motor	{06.009}	Disable (0), Enable (1), Fwd Only (2), Rev Only (3)			Disable (0)			RW	Txt			US
	Rated Speed Optimisation Select	{05.016}	Disabled (0), Classic Slow (1), Classic Fast (2), Combined (3), VARs Only (4), Voltage Only (5)				Disabled (0)		RW	Txt			US
00.034	User Security Code	{11.030}	0 to 2 <sup>31</sup> -1			0			RW	Num	ND	NC	PT
00.038	Current Controller Kp Gain	{04.013}	0 to 30000			20	150		RW	Num			US
00.039	Current Controller Ki Gain	{04.014}	0 to 30000			40	2000		RW	Num			US
00.040	Auto-tune	{05.012}	0 to 2	0 to 5	0 to 6	0			RW	Num		NC	
00.041	Maximum Switching Frequency	{05.018}	2 kHz (0), 3 kHz (1), 4 kHz (2), 6 kHz (3), 8 kHz (4), 12 kHz (5), 16 kHz (6)			8 kHz (4)			RW	Txt		RA	US
00.042	Number Of Motor Poles	{05.011}	Automatic (0) to 480 Poles (240)			Automatic (0)		6 Poles (3)	RW	Num			US
00.043	Rated Power Factor*	{05.010}	0.000 to 1.000				0.850		RW	Num		RA	US
	Position Feedback Phase Angle	{03.025}			0.0 to 359.9°			0.0°	RW	Num	ND		US
00.044	Rated Voltage	{05.009}	0 to VM_AC_VOLTAGE_SET V			200 V drive: 230 V 50 Hz default 400V drive: 400 V 60 Hz default 400V drive: 460 V			RW	Num		RA	US
00.045	Rated Speed	{05.008}	0 to 33000 rpm	0.00 to 33000.00 rpm		50 Hz default: 1500 rpm 60 Hz default: 1800rpm	50 Hz default: 1450.00 rpm 60 Hz default: 1750.00 rpm	3000.00 rpm	RW	Num			US
00.046	Rated Current	{05.007}	0.000 to VM_RATED_CURRENT A			Maximum Heavy Duty Rating (11.032)			RW	Num		RA	US
00.047	Rated Frequency	{05.006}	0.0 to 550.0 Hz				50 Hz default: 50.0 Hz 60 Hz default: 60.0 Hz		RW	Num			US
	Volts Per 1000 rpm	{05.033}			0 to 10,000 V			98	RW	Num			US
00.048	User Drive Mode	{11.031}	Open-loop (1), RFC-A (2), RFC-S (3), Regen (4)			Open-loop (1)	RFC-A (2)	RFC-S (3)	RW	Txt	ND	NC	PT
00.049	User Security Status	{11.044}	Menu 0 (0), All Menus (1), Read-only Menu 0 (2), Read-only (3), Status Only (4), No Access (5)			Menu 0 (0)			RW	Txt	ND		PT
00.050	Software Version	{11.029}	0 to 999999999						RO	Num	ND	NC	PT
00.051	Action On Trip Detection	{10.037}	0 to 31			0			RW	Bin			US
00.053	Motor Thermal Time Constant 1	{04.015}	1.0 to 3000.0 s			89.0 s			RW	Num			US

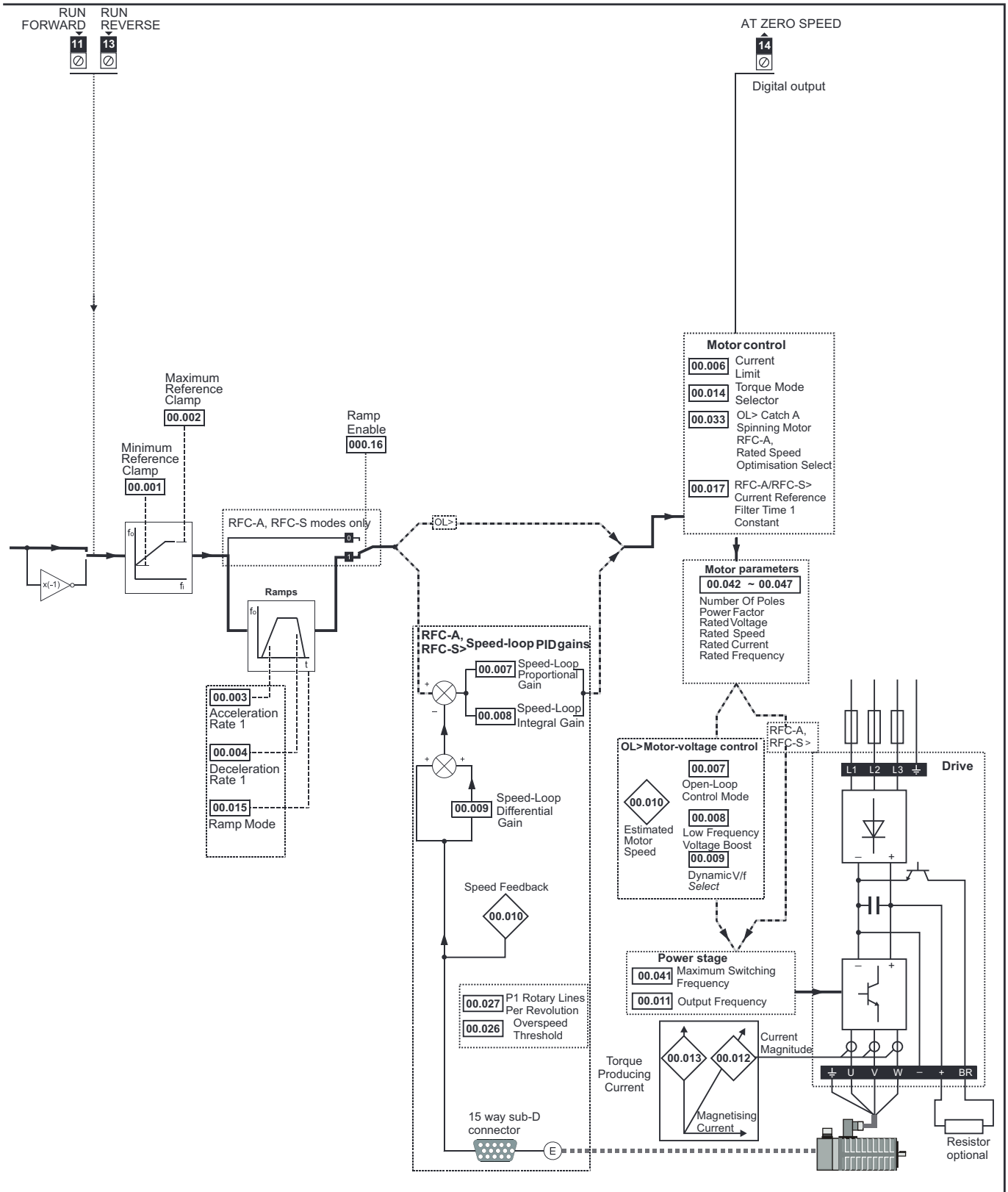
\* Following a rotating autotune Pr 00.043 {05.010} is continuously written by the drive, calculated from the value of Stator Inductance (Pr 05.025). To manually enter a value into Pr 00.043 {05.010}, Pr 05.025 will need to be set to 0. Please refer to the description of Pr 05.010 in the *Parameter Reference Guide* for further details.

RW	Read / Write	RO	Read only	Num	Number parameter	Bit	Bit parameter	Txt	Text string	Bin	Binary parameter	FI	Filtered
ND	No default value	NC	Not copied	PT	Protected parameter	RA	Rating dependent	US	User save	PS	Power-down save	DE	Destination
IP	IP address	Mac	Mac address	Date	Date parameter	Time	Time parameter						

Safety information	Product information	Mechanical installation	Electrical installation	Getting started	<b>Basic parameters</b>	Running the motor	Optimization	Drive communication	SD Card Operation	Onboard PLC	Advanced parameters	Diagnostics	UL listing information
--------------------	---------------------	-------------------------	-------------------------	-----------------	-------------------------	-------------------	--------------	---------------------	-------------------	-------------	---------------------	-------------	------------------------

Figure 6-1 Menu 0 logic diagram





## 6.3 Parameter descriptions

### 6.3.1 Pr mm.000

Pr mm.000 is available in all menus, commonly used functions are provided as text strings in Pr mm.000 shown in Table 6-1. The functions in Table 6-1 can also be selected by entering the appropriate numeric values (as shown in Table 6-2) in Pr mm.000. For example, enter 4001 in Pr mm.000 to store drive parameters on an SD Card.

**Table 6-1 Commonly used functions in xx.000**

Value	Equivalent value	String	Action
0	0	[No Action]	
1001	1	[Save parameters]	Save parameters under all conditions
6001	2	[Load file 1]	Load the drive parameters or user program file from SD Card file 001
4001	3	[Save to file 1]	Transfer the drive parameters to parameter file 001
6002	4	[Load file 2]	Load the drive parameters or user program file from SD Card file 002
4002	5	[Save to file 2]	Transfer the drive parameters to parameter file 002
6003	6	[Load file 3]	Load the drive parameters or user program file from SD Card file 003
4003	7	[Save to file 3]	Transfer the drive parameters to parameter file 003
12000	8	[Show non-default]	Displays parameters that are different from defaults
12001	9	[Destinations]	Displays parameters that are set
1233	10	[Reset 50Hz defs]	Load parameters with standard (50 Hz) defaults
1244	11	[Reset 60Hz defs]	Load parameters with US (60 Hz) defaults
1070	12	[Reset modules]	Reset all option modules
11001	13	[Read enc. NP P1]	Transfer electronic nameplate motor parameters to the drive from the P1 encoder
11051	14	[Read enc. NP P2]	Transfer electronic nameplate motor parameters to the drive from the P2 encoder

**Table 6-2 Functions in Pr mm.000**

Value	Action
1000	Save parameters when <i>Under Voltage Active</i> (Pr <b>10.016</b> ) is not active and <i>Low Under Voltage Threshold Select</i> mode (Pr <b>06.067</b> = Off) is not active.
1001	Save parameters under all conditions
1070	Reset all option modules
1233	Load standard (50 Hz) defaults
1234	Load standard (50 Hz) defaults to all menus except option module menus (i.e 15 to 20 and 24 to 28)
1244	Load US (60 Hz) defaults
1245	Load US (60 Hz) defaults to all menus except option module menus (i.e 15 to 20 and 24 to 28)
1253	Change drive mode and load standard (50 Hz) defaults
1254	Change drive mode and load US (60 Hz) defaults
1255	Change drive mode and load standard (50 Hz) defaults except for menus 15 to 20 and 24 to 28
1256	Change drive mode and load US (60 Hz) defaults except for menus 15 to 20 and 24 to 28
1299	Reset {Stored HF} trip.
2001*	Create a boot file on a non-volatile media card based on the present drive parameters including all Menu 20 parameters
4yyy*	SD card: Transfer the drive parameters to parameter file xxx
5yyy*	SD card: Transfer the onboard user program to onboard user program file xxx
6yyy*	SD card: Load the drive parameters from parameter file xxx or the onboard user program from onboard user program file xxx
7yyy*	SD card: Erase file xxx
8yyy*	SD card: Compare the data in the drive with file xxx
9555*	SD card: Clear the warning suppression flag
9666*	SD card: Set the warning suppression flag
9777*	SD card: Clear the read-only flag
9888*	SD card: Set the read-only flag
59999	Delete onboard user program
110S0	Transfer electronic nameplate motor object parameters from the drive to an encoder connected to the drive or an option module.
110S1	Transfer electronic nameplate motor objects parameters from an encoder connected to the drive or option module to the drive parameters.
110S2	As 110S0, but for performance object 1
110S3	As 110S1, but for performance object 1
110S4	As 110S0, but for performance object 2
110S5	As 110S1, but for performance object 2
110S6	Transfer electronic nameplate motor object parameters from the drive to an encoder connected to the drive or an option module in the Unidrive SP format.
12000**	Only display parameters that are different from their default value. This action does not require a drive reset.
12001**	Only display parameters that are used to set-up destinations (i.e. DE format bit is 1). This action does not require a drive reset.
15xxx*	Transfer the user program in an option module installed in slot 1 to a non-volatile media card file xxx
16xxx*	Transfer the user program in an option module installed in slot 2 to a non-volatile media card file xxx
17xxx*	Transfer the user program in an option module installed in slot 3 to a non-volatile media card file xxx
18xxx*	Transfer the user program from file xxx in a non-volatile media card to an option module installed in slot 1.
19xxx*	Transfer the user program from file xxx in a non-volatile media card to an option module installed in slot 2.
20xxx*	Transfer the user program from file xxx in a non-volatile media card to an option module installed in slot 3.

\* See Chapter 10 *SD Card Operation* on page 117 for more information on these functions.

\*\* These functions do not require a drive reset to become active. All other functions require a drive reset to initiate the function. Equivalent values and strings are also provided in the table above.

## 6.4 Full descriptions

Table 6-3 Key to parameter table coding

Coding	Attribute
<b>RW</b>	Read/Write: can be written by the user
<b>RO</b>	Read only: can only be read by the user
<b>Bit</b>	1 bit parameter. 'On' or 'Off' on the display
<b>Num</b>	Number: can be uni-polar or bi-polar
<b>Txt</b>	Text: the parameter uses text strings instead of numbers.
<b>Bin</b>	Binary parameter
<b>IP</b>	IP Address parameter
<b>Mac</b>	Mac Address parameter
<b>Date</b>	Date parameter
<b>Time</b>	Time parameter
<b>Chr</b>	Character parameter
<b>FI</b>	Filtered: some parameters which can have rapidly changing values are filtered when displayed on the drive keypad for easy viewing.
<b>DE</b>	Destination: This parameter selects the destination of an input or logic function.
<b>RA</b>	Rating dependent: this parameter is likely to have different values and ranges with drives of different voltage and current ratings. Parameters with this attribute will be transferred to the destination drive by non-volatile storage media when the rating of the destination drive is different from the source drive and the file is a parameter file. However, the values will be transferred if only the current rating is different and the file is a difference from default type file.
<b>ND</b>	No default: The parameter is not modified when defaults are loaded
<b>NC</b>	Not copied: not transferred to or from non-volatile media during copying.
<b>PT</b>	Protected: cannot be used as a destination.
<b>US</b>	User save: parameter saved in drive EEPROM when the user initiates a parameter save.
<b>PS</b>	Power-down save: parameter automatically saved in drive EEPROM when the under volts (UV) state occurs.

### 6.4.1 Parameter x.00

00.000 {mm.000}		Parameter zero										
RW	Num						ND	NC	PT			
↕	0 to 65,535											

### 6.4.2 Speed limits

00.001 {01.007}		Minimum Reference Clamp										
RW	Num											US
<b>OL</b>												0.0 Hz
<b>RFC-A</b>	↕											0.0 rpm
<b>RFC-S</b>												

(When the drive is jogging, [00.001] has no effect.)

#### Open-loop

Set Pr **00.001** at the required minimum output frequency of the drive for both directions of rotation. The drive speed reference is scaled between Pr **00.001** and Pr **00.002**. [00.001] is a nominal value; slip compensation may cause the actual frequency to be higher.

#### RFC-A / RFC-S

Set Pr **00.001** at the required minimum motor speed for both directions of rotation. The drive speed reference is scaled between Pr **00.001** and Pr **00.002**.

00.002 {01.006}		Maximum Reference Clamp										
RW	Num											US
<b>OL</b>												50Hz default: 50.0 Hz 60Hz default: 60.0 Hz
<b>RFC-A</b>	↕											50Hz default: 1500.0 rpm 60Hz default: 1800.0 rpm
<b>RFC-S</b>												3000.0 rpm

(The drive has additional over-speed protection).

#### Open-loop

Set Pr **00.002** at the required maximum output frequency for both directions of rotation. The drive speed reference is scaled between Pr **00.001** and Pr **00.002**. [00.002] is a nominal value; slip compensation may cause the actual frequency to be higher.

#### RFC-A / RFC-S

Set Pr **00.002** at the required maximum motor speed for both directions of rotation. The drive speed reference is scaled between Pr **00.001** and Pr **00.002**.

For operating at high speeds see section 8.5 *High speed operation* on page 92.

### 6.4.3 Ramps, speed reference selection, current limit

00.003 {02.011}		Acceleration Rate 1											
RW	Num											US	
<b>OL</b>												0.0 to VM_ACCEL_RATE s/100 Hz	5.0 s/100 Hz
<b>RFC-A</b>	↕											0.000 to VM_ACCEL_RATE s/1000 rpm	2.000 s/1000 rpm
<b>RFC-S</b>													0.200 s/1000 rpm

Set Pr **00.003** at the required rate of acceleration.

Note that larger values produce lower acceleration. The rate applies in both directions of rotation.

00.004 {02.021}		Deceleration Rate 1											
RW	Num											US	
<b>OL</b>												0.0 to VM_ACCEL_RATE s/100 Hz	10.0 s/100 Hz
<b>RFC-A</b>	↕											0.000 to VM_ACCEL_RATE s/1000 rpm	2.000 s/1000 rpm
<b>RFC-S</b>													0.200 s/1000 rpm

Set Pr **00.004** at the required rate of deceleration.

Note that larger values produce lower deceleration. The rate applies in both directions of rotation.

00.005 {01.014}		Reference Selector										
RW	Txt											US
<b>OL</b>												A1 Preset (1)
<b>RFC-A</b>	↕											
<b>RFC-S</b>												

Use Pr **00.005** to select the required frequency/speed reference as follows:

Setting	Description
A1 A2	0 Analog input 1 OR analog input 2 selectable by digital input, terminal 28
A1 Preset	1 Analog input 1 OR preset frequency/speed
A2 Preset	2 Analog input 2 OR preset frequency/speed
Preset (3)	3 Pre-set frequency/speed
Keypad (4)	4 Keypad mode
Precision (5)	5 Precision reference
Keypad Ref (6)	6 Keypad Reference

00.006 {04.007} Symmetrical Current Limit	
RW	Num
OL	165 %
RFC-A	0.0 to VM_MOTOR1_CURRENT_LIMIT %
RFC-S	250 %

Pr **00.006** limits the maximum output current of the drive (and hence maximum motor torque) to protect the drive and motor from overload. Set Pr **00.006** at the required maximum torque as a percentage of the rated torque of the motor, as follows:

$$[00,006] = \frac{T_R}{T_{RATED}} \times 100 (\%)$$

Where:

$T_R$  Required maximum torque  
 $T_{RATED}$  Motor rated torque

Alternatively, set Pr **00.006** at the required maximum active (torque-producing) current as a percentage of the rated active current of the motor, as follows:

$$[00,006] = \frac{I_R}{I_{RATED}} \times 100 (\%)$$

Where:

$I_R$  Required maximum active current  
 $I_{RATED}$  Motor rated active current

### 6.4.4 Voltage boost, (open-loop), Speed-loop PID gains (RFC-A / RFC-S)

00.007 {05.014} Open-loop Control Mode (OL)	
00.007 {03.010} Speed Controller Proportional Gain Kp1 (RFC)	
RW	Txt/Num
OL	Ur S (0), Ur (1), Fixed (2), Ur Auto (3), Ur I (4), Square (5)
RFC-A	0.0300 s/rad
RFC-S	0.0100 s/rad

#### Open-loop

There are six voltage modes available, which fall into two categories, vector control and fixed boost. For further details, refer to ???section Pr 00.007 {05.014} Open Loop Control Mode on page 82.

#### RFC-A/ RFC-S

Pr **00.007 (03.010)** operates in the feed-forward path of the speed-control loop in the drive. See Figure 12-4 on page 144 for a schematic of the speed controller. For information on setting up the speed controller gains, refer to Chapter 8 *Optimization* on page 76.

00.008 {05.015} Low Frequency Voltage Boost (OL)	
00.008 {03.011} Speed Controller Integral Gain Ki1 (RFC)	
RW	Num
OL	0.0 to 25.0 %
RFC-A	0.10 s <sup>2</sup> /rad
RFC-S	1.00 s <sup>2</sup> /rad

#### Open-loop

When *Open-loop Control Mode* (00.007) is set at **Fd** or **SrE**, set Pr **00.008 (05.015)** at the required value for the motor to run reliably at low speeds.

Excessive values of Pr **00.008** can cause the motor to be overheated.

#### RFC-A/ RFC-S

Pr **00.008 (03.011)** operates in the feed-forward path of the speed-control loop in the drive. See Figure 12-4 on page 144 for a schematic of the speed controller. For information on setting up the speed controller gains, refer to Chapter 8 *Optimization* on page 76.

00.009 {05.013} Dynamic V to F Select (OL)	
00.009 {03.012} Speed Controller Differential Feedback Gain Kd 1 (RFC)	
RW	Bit
OL	Off (0) or On (1)
RFC-A	0.00000 to 0.65535 1/rad
RFC-S	0.00000 1/rad

#### Open-loop

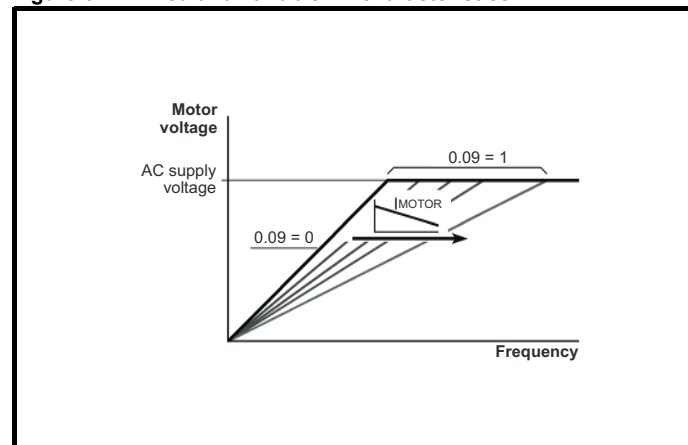
Set Pr **00.009 (05.013)** at 0 when the V/f characteristic applied to the motor is to be fixed. It is then based on the rated voltage and frequency of the motor.

Set Pr **00.009** at 1 when reduced power dissipation is required in the motor when it is lightly loaded. The V/f characteristic is then variable resulting in the motor voltage being proportionally reduced for lower motor currents. Figure 6-2 shows the change in V/f slope when the motor current is reduced.

#### RFC-A / RFC-S

Pr **00.009 (03.012)** operates in the feedback path of the speed-control loop in the drive. See Figure 12-4 *Menu 3 RFC-A, RFC-S logic diagram* on page 144 for a schematic of the speed controller. For information on setting up the speed controller gains, refer to Chapter 8 *Optimization* on page 76.

Figure 6-2 Fixed and variable V/f characteristics



## 6.4.5 Monitoring

00.010 {05.004} Motor Rpm									
RO	Bit								US
OL	↕	±180000 rpm		⇒					

### Open-loop

Pr **00.010 (05.004)** indicates the value of motor speed that is estimated from the following:

**02.001** Post Ramp Reference

**00.042** Number Of Motor Poles

00.010 {03.002} Speed Feedback									
RO	Num	FI			ND	NC	PT		
RFC-A	↕	VM_SPEED rpm		⇒					
RFC-S									

### RFC-A / RFC-S

Pr **00.010 (03.002)** indicates the value of motor speed that is obtained from the speed feedback.

00.011 {05.001} Output Frequency (OL)									
00.011 {03.029} P1 Position (RFC)									
RO	Num	FI			ND	NC	PT		
OL	↕	VM_SPEED_FREQ_REF Hz		⇒					
RFC-A									
RFC-S	↕	0 to 65535		⇒					

### Open-loop and RFC-A

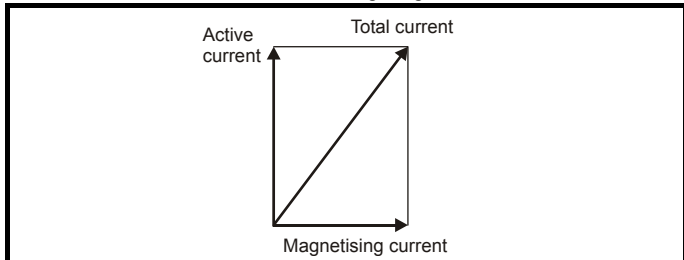
Pr **00.011** displays the frequency at the drive output.

### RFC-S

Pr **00.011** displays the position of the encoder in mechanical values of 0 to 65,535. There are 65,536 units to one mechanical revolution.

00.012 {04.001} Current Magnitude									
RO	Bit	FI			ND	NC	PT		
OL	↕	0.000 to VM_DRIVE_CURRENT_UNIPOLAR A		⇒					
RFC-A									
RFC-S									

Pr **00.012** displays the rms value of the output current of the drive in each of the three phases. The phase currents consist of an active component and a reactive component, which can form a resultant current vector as shown in the following diagram.



The active current is the torque producing current and the reactive current is the magnetizing or flux-producing current.

00.013 {04.002} Torque Producing Current									
RO	Bit	FI			ND	NC	PT		
OL	↕	VM_DRIVE_CURRENT A		⇒					
RFC-A									
RFC-S									

When the motor is being driven below its rated speed, the torque is proportional to [00.013].

## 6.4.6 Jog reference, Ramp mode selector, Stop and torque mode selectors

Pr **00.014** is used to select the required control mode of the drive as follows:

00.014 {04.011} Torque Mode Selector									
RW	Num								US
OL	↕	0 or 1		⇒	0				
RFC-A	↕	0 to 5		⇒	0				
RFC-S									

Setting	Open-Loop	RFC-A/S
0	Frequency control	Speed control
1	Torque control	Torque control
2		Torque control with speed override
3		Coiler/uncoiler mode
4		Speed control with torque feed-forward
5		Bi-directional torque control with speed override

00.015 {02.004} Ramp Mode Select									
RW	Txt								US
OL	↕	Fast (0), Standard (1), Std boost (2)		⇒	Standard (1)				
RFC-A	↕	Fast (0), Standard (1)		⇒	Fast (0)				
RFC-S									

Pr **00.015** sets the ramp mode of the drive as shown below:

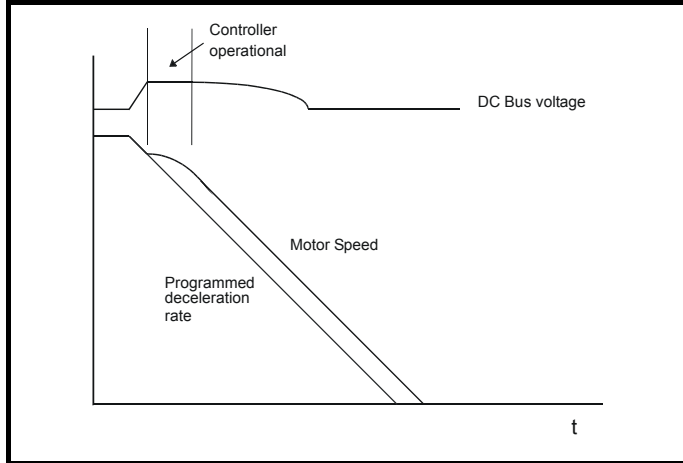
### 0: Fast ramp

Fast ramp is used where the deceleration follows the programmed deceleration rate subject to current limits. This mode must be used if a braking resistor is connected to the drive.

### 1: Standard ramp

Standard ramp is used. During deceleration, if the voltage rises to the standard ramp level (Pr **02.008**) it causes a controller to operate, the output of which changes the demanded load current in the motor. As the controller regulates the link voltage, the motor deceleration increases as the speed approaches zero speed. When the motor deceleration rate reaches the programmed deceleration rate the controller ceases to operate and the drive continues to decelerate at the programmed rate. If the standard ramp voltage (Pr **02.008**) is set lower than the nominal DC bus level the drive will not decelerate the motor, but it will coast to rest.

The output of the ramp controller (when active) is a current demand that is fed to the frequency changing current controller (Open-loop modes) or the torque producing current controller (RFC-A or RFC-S modes). The gain of these controllers can be modified with Pr **00.038** and Pr **00.039**.



## 2: Standard ramp with motor voltage boost

This mode is the same as normal standard ramp mode except that the motor voltage is boosted by 20 %. This increases the losses in the motor, dissipating some of the mechanical energy as heat giving faster deceleration.

00.016 {02.002} Ramp Enable	
RW	Bit
OL	↕
RFC-A	↕
RFC-S	↕
	Off (0) or On (1)
	⇒
	On (1)

Setting Pr **00.016** to 0 allows the user to disable the ramps. This is generally used when the drive is required to closely follow a speed reference which already contains acceleration and deceleration ramps.

00.017 {04.012} Current Reference Filter Time Constant	
RW	Num
RFC-A	↕
RFC-S	↕
	0.0 to 25.0 ms
	⇒
	0.0 ms

### RFC-A / RFC-S

A first order filter, with a time constant defined by Pr **00.017**, is provided on the current demand to reduce acoustic noise and vibration produced as a result of position feedback quantisation noise. The filter introduces a lag in the speed loop, and so the speed loop gains may need to be reduced to maintain stability as the filter time constant is increased.

00.018 {03.123} P1 Thermistor Fault Detection	
RW	Bit
OL	↕
RFC-A	↕
RFC-S	↕
	None (0), Temperature (1), Temp and short (2)
	⇒
	None (0)
	Temperature (1)

Defines the fault detection for the P1 thermistor input:



P1 Thermistor Fault Detection (03.123)	Fault detection
0: None	No detection active
1: Temperature	Over temperature detection
2: Temp and short	Over temperature and short circuit detection

If over temperature detection is enabled a *Thermistor.001* trip is initiated if *P1 Thermistor Feedback* (03.119) is above the level defined by *P1 Thermistor Trip Threshold* (03.120). The trip cannot be reset until *P1 Thermistor Feedback* (03.119) is below *P1 Thermistor Reset Threshold* (03.121).

If short circuit detection is enabled then a *Th Short Circuit.001* is initiated if *P1 Thermistor Feedback* (03.119) is below 50 Ohms.

00.022 {01.010} Bipolar Reference Enable	
RW	Bit
OL	↕
RFC-A	↕
RFC-S	↕
	OFF (0) or On (1)
	⇒
	OFF (0)

Pr **00.022** determines whether the reference is uni-polar or bi-polar as follows:

Pr 00.022	Function
0	Unipolar speed/frequency reference 
1	Bipolar speed/frequency reference 

00.023 {01.005} Jog Reference	
RW	Num
OL	↕
RFC-A	↕
RFC-S	↕
	0.0 to 400.0 Hz
	⇒
	0.0
	0.0 to 4000.0 rpm
	⇒
	0.0

Enter the required value of jog frequency/speed.

The frequency/speed limits affect the drive when jogging as follows:

Frequency-limit parameter	Limit applies
Pr <b>00.001</b> Minimum reference clamp	No
Pr <b>00.002</b> Maximum reference clamp	Yes

00.024 {01.021} Preset Reference 1	
RW	Num
OL	↕
RFC-A	↕
RFC-S	↕
	VM_SPEED_FREQ_REF
	⇒
	0.0

00.025 {01.022} Preset Reference 2	
RW	Num
OL	↕
RFC-A	↕
RFC-S	↕
	VM_SPEED_FREQ_REF
	⇒
	0.0

<b>00.026 {01.023}</b>	<b>Preset Reference 3 (OL)</b>												
<b>00.026 {03.008}</b>	<b>Overspeed Threshold (RFC)</b>												
RW	Num											US	
<b>OL</b>	↕	VM_SPEED_FREQ_REF Hz											
<b>RFC-A</b>													0.0
<b>RFC-S</b>	↕	0 to 40000 rpm											

**Open-loop**

If the preset reference has been selected (see Pr **00.005**), the speed at which the motor runs is determined by these parameters.

**RFC-A / RFC-S**

If the speed feedback (Pr **00.010**) exceeds this level in either direction, an overspeed trip is produced. If this parameter is set to zero, the overspeed threshold is automatically set to 120 % x SPEED\_FREQ\_MAX.

<b>00.027 {01.024}</b>	<b>Preset Reference 4 (OL)</b>												
<b>00.027 {03.034}</b>	<b>P1 Rotary Lines Per Revolution (RFC)</b>												
RW	Num											US	
<b>OL</b>	↕	VM_SPEED_FREQ_REF Hz											0.0
<b>RFC-A</b>													1024
<b>RFC-S</b>	↕	1 to 100000											4096

**Open-loop**

Refer to Pr **00.024** to Pr **00.026**.

**RFC-A / RFC-S**

Enter in Pr **00.027** the number of lines per revolution of the drive encoder.

<b>00.028 {06.013}</b>	<b>Enable Auxiliary Key</b>												
RW	Txt												US
<b>OL</b>													
<b>RFC-A</b>	↕	Disabled (0), Forward/Reverse (1), Run Reverse (2)											Disabled (0)
<b>RFC-S</b>													

When a keypad is installed, this parameter enables the forward/reverse key.

<b>00.029 {11.036}</b>	<b>NV Media Card File Previously Loaded</b>												
RO	Num						NC	PT					
<b>OL</b>													
<b>RFC-A</b>	↕	0 to 999											
<b>RFC-S</b>													

This parameter shows the number of the data block last transferred from an SD Card to the drive.

<b>00.030 {11.42}</b>	<b>Parameter Cloning</b>												
RW	Txt							NC				US*	
<b>OL</b>													
<b>RFC-A</b>	↕	None (0), Read (1), Program (2), Auto (3), Boot (4)											None (0)
<b>RFC-S</b>													

\* Only a value of 3 or 4 in this parameter is saved.

**NOTE**

If Pr **00.030** is equal to 1 or 2 this value is not transferred to the EEPROM or the drive. If Pr **00.030** is set to a 3 or 4 the value is transferred.

Pr String	Pr value	Comment
None	0	Inactive
Read	1	Read parameter set from the SD Card
Program	2	Programming a parameter set to the SD Card
Auto	3	Auto save
Boot	4	Boot mode

For further information, please refer to Chapter 10 *SD Card Operation* on page 117.

<b>00.031 {11.033}</b>	<b>Drive Rated Voltage</b>												
RO	Txt							ND	NC	PT			
<b>OL</b>													
<b>RFC-A</b>	↕	200 V (0), 400 V (1)											
<b>RFC-S</b>													

Pr **00.031** indicates the voltage rating of the drive.

<b>00.032 {11.032}</b>	<b>Maximum Heavy Duty Rating</b>												
RO	Num							ND	NC	PT			
<b>OL</b>													
<b>RFC-A</b>	↕	0.000 to 99999.999 A											
<b>RFC-S</b>													

Pr **00.032** indicates the maximum continuous Heavy Duty current rating.

<b>00.033 {06.009}</b>	<b>Catch A Spinning Motor (OL)</b>												
<b>00.033 {05.016}</b>	<b>Rated Speed Optimisation Select (RFC-A)</b>												
RW	Txt												US
<b>OL</b>	↕	Disable (0), Enable (1), Fwd Only (2), Rev Only (3)											Disable (0)
<b>RFC-A</b>	↕	Disabled (0), Classic Slow (1), Classic Fast (2), Combined (3), VARs Only (4), Voltage Only (5)											Disabled (0)

**Open-loop**

When the drive is enabled with Pr **00.033** = 0, the output frequency starts at zero and ramps to the required reference. When the drive is enabled when Pr **00.033** has a non-zero value, the drive performs a start-up test to determine the motor speed and then sets the initial output frequency to the synchronous frequency of the motor.

Restrictions may be placed on the frequencies detected by the drive as follows:

Pr 00.033	Pr string	Function
0	Disable	Disabled
1	Enable	Detect all frequencies
2	Fwd only	Detect positive frequencies only
3	Rev only	Detect negative frequencies only

## RFC-A

The *Rated Frequency* (00.047) and *Rated Speed* (00.045) are used to define the rated slip of the motor. The rated slip is used in sensorless mode (*Sensorless Mode Active* (03.078) = 1) to correct the motor speed with load. When this mode is active *Rated Speed Optimisation Select* (00.033) has no effect.

If sensorless mode is not active (*Sensorless Mode Active* (03.078) = 0) the rated slip is used in the motor control algorithm and an incorrect value of slip can have a significant effect on the motor performance. If *Rated Speed Optimisation Select* (00.033) = 0 then the adaptive control system is disabled. However, if *Rated Speed Optimisation Select* (00.033) is set to a non-zero value the drive can automatically adjust the *Rated Speed* (00.045) to give the correct value of rated slip.

*Rated Speed* (00.045) is not saved at power-down, and so when the drive is powered-down and up again it will return to the last value saved by the user. The rate of convergence and the accuracy of the adaptive controller reduces at low output frequency and low load. The minimum frequency is defined as a percentage of *Rated Frequency* (00.047) by *Rated Speed Optimisation Minimum Frequency* (05.019). The minimum load is defined as a percentage of rated load by *Rated Speed Optimisation Minimum Load* (05.020). The adaptive controller is enabled when a motoring or regenerative load rises above *Rated Speed Optimisation Minimum Load* (05.020) + 5 %, and is disabled again when it falls below *Rated Speed Optimisation Minimum Load* (05.020). For best optimisation results the correct values of *Stator Resistance* (05.017), *Transient Inductance* (05.024), *Stator Inductance* (05.025), *Saturation Breakpoint 1* (05.029), *Saturation Breakpoint 2* (05.062), *Saturation Breakpoint 3* (05.030) and *Saturation Breakpoint 4* (05.063) should be used.

00.034 {11.030}		User security code							
RW	Num				ND	NC	PT	US	
OL									
RFC-A	⇕	0 to 2 <sup>31</sup> -1				⇒	0		
RFC-S									

If any number other than 0 is programmed into this parameter, user security is applied so that no parameters except Pr **00.049** can be adjusted with the keypad. When this parameter is read via a keypad it appears as zero. For further details refer to section 5.9.3 *User Security Code* on page 39.

00.038 {04.013}		Current Controller Kp Gain							
RW	Num							US	
OL								20	
RFC-A	⇕	0 to 30000				⇒	150		
RFC-S									

00.039 {04.014}		Current Controller Ki Gain							
RW	Num							US	
OL	⇕							40	
RFC-A	⇕	0 to 30000				⇒	2000		
RFC-S									

These parameters control the proportional and integral gains of the current controller used in the open loop drive. The current controller either provides current limits or closed loop torque control by modifying the drive output frequency. The control loop is also used in its torque mode during line power supply loss, or when the controlled mode standard ramp is active and the drive is decelerating, to regulate the flow of current into the drive.

00.040 {05.012}		Auto-tune							
RW	Num						NC		
OL	⇕	0 to 2				⇒	0		
RFC-A	⇕	0 to 4				⇒			
RFC-S	⇕	0 to 5				⇒			

## Open-Loop

There are two autotune tests available in open loop mode, a stationary and a rotating test. A rotating autotune should be used whenever possible so the measured value of power factor of the motor is used by the drive.

- A stationary autotune can be used when the motor is loaded and it is not possible to remove the load from the motor shaft. The stationary test measures the *Stator Resistance* (05.017), *Transient Inductance* (05.024), *Maximum Deadtime Compensation* (05.059) and *Current At Maximum Deadtime Compensation* (05.060) which are required for good performance in vector control modes (see *Open Loop Control Mode* (00.007), later in this table). The stationary autotune does not measure the power factor of the motor so the value on the motor nameplate must be entered into Pr **00.043**. To perform a Stationary autotune, set Pr **00.040** to 1, and provide the drive with both an enable signal (terminal 2 and 6) and a run signal (terminal 11 or 13).
- A rotating autotune should only be used if the motor is unloaded. A rotating autotune first performs a stationary autotune, as above, then a rotating test is performed in which the motor is accelerated with currently selected ramps up to a frequency of *Rated Frequency* (05.006) x 2/3, and the frequency is maintained at that level for 4 seconds. *Stator Inductance* (05.025) is measured and this value is used in conjunction with other motor parameters to calculate *Rated Power Factor* (00.043). To perform a Rotating autotune, set Pr **00.040** to 2, and provide the drive with both an enable signal (terminal 2 and 6) and a run signal (terminal 11 or 13).

Following the completion of an autotune test the drive will go into the inhibit state. The drive must be placed into a controlled disable condition before the drive can be made to run at the required reference. The drive can be put in to a controlled disable condition by removing the Safe Torque Off signal from terminal 2 and 6, setting the *Drive Enable* (06.015) to OFF (0) or disabling the drive via the *Control Word* (06.042) and *Control Word Enable* (06.043).

## RFC-A

There are four autotune tests available in RFC-A mode, a stationary test, a rotating test, two mechanical load measurement tests. A stationary autotune will give moderate performance whereas a rotating autotune will give improved performance as it measures the actual values of the motor parameters required by the drive. A mechanical load measurement test should be performed separately to a stationary or rotating autotune.

### NOTE

It is highly recommended that a rotating autotune is performed (Pr **00.040** set to 2).

- A stationary autotune can be used when the motor is loaded and it is not possible to remove the load from the motor shaft. The stationary autotune measures the *Stator Resistance* (05.017) and *Transient Inductance* (05.024) of the motor. These are used to calculate the current loop gains, and at the end of the test the values in Pr **00.038** and Pr **00.039** are updated. A stationary autotune does not measure the power factor of the motor so the value on the motor nameplate must be entered into Pr **00.043**. To perform a Stationary autotune, set Pr **00.040** to 1, and provide the drive with both an enable signal (terminal 2 and 6) and a run signal (terminal 11 or 13).

- A rotating autotune should only be used if the motor is unloaded. A rotating autotune first performs a stationary autotune, a rotating test is then performed which the motor is accelerated with currently selected ramps up to a frequency of *Rated Frequency* (00.047) x 2/3, and the frequency is maintained at the level for up to 40 s. During the rotating autotune the *Stator Inductance* (05.025), and the motor saturation breakpoints (Pr **05.029**, Pr **05.030**, Pr **06.062** and Pr **05.063**) are modified by the drive. The *Motor Rated Power Factor* (00.043) is also modified by the *Stator Inductance* (05.025). The No-Load motor core losses are measured and written to *No-Load Core Loss* (04.045). To perform a Rotating autotune, set Pr **00.040** to 2, and provide the drive with both an enable signal (terminal 2 and 6) and a run signal (terminal 11 or 13).

Following the completion of an autotune test the drive will go into the inhibit state. The drive must be placed into a controlled disable condition before the drive can be made to run at the required reference. The drive can be put in to a controlled disable condition by removing the Safe Torque Off signal from terminal 2 and 6, setting the *Drive Enable* (06.015) to OFF (0) or disabling the drive via the control word (Pr **06.042** & Pr **06.043**).

### RFC-S

There are five autotune tests available in RFC-S mode, a stationary autotune, a rotating autotune, two mechanical load measurement tests and a locked rotor test to measure load dependent parameters.

#### Stationary Autotune

The stationary autotune can be used when the motor is loaded and it is not possible uncouple the load from motor shaft. This test can be used to measure all the necessary parameters for basic control. During the stationary autotune, a test is performed to locate the flux axis of the motor. However this test may not be able to calculate such an accurate value for the Position Feedback Phase Angle (00.043) as compared to rotating autotune. A stationary test is performed to measure *Stator Resistance* (05.017), *Ld* (05.024), *Maximum Deadtime Compensation* (05.059), *Current At Maximum Deadtime Compensation* (05.060), *No Load Lq* (05.072). If *Enable Stator Compensation* (05.049) = 1 then *Stator Base Temperature* (05.048) is made equal to *Stator Temperature* (05.046). The *Stator Resistance* (05.017) and the *Ld* (05.024) are then used to set up *Current controller Kp Gain* (00.038) and *Current Controller Ki Gain* (00.039). If sensorless mode is not selected then *Position Feedback Phase Angle* (00.043) is set up for the position from the position feedback interface selected with *Motor Control Feedback Select* (03.026). To perform a Stationary autotune, set Pr **00.040** to 1, and provide the drive with both an enable signal (terminal 2 and 6) and a run signal (terminal 11 or 13).

#### Rotating Autotune

The rotating autotune must be performed on unloaded motor. This test can be used to measure all the necessary parameters for the basic control and parameters for cancelling the effects of the cogging torque. During the rotating autotune, *Rated Current* (00.046) is applied and the motor is rotated by 2 electrical revolutions (i.e. up to 2 mechanical revolutions) in the required direction. If sensorless mode is not selected then the *Position Feedback Phase Angle* (00.043) is set-up for the position from the position feedback interface selected with *Motor Control Feedback Select* (03.026). A stationary test is then performed to measure *Stator Resistance* (05.017), *Ld* (05.024), *Maximum Deadtime Compensation* (05.059), *Current At Maximum Deadtime Compensation* (05.060) and *No Load Lq* (05.072). *Stator Resistance* (05.017) and *Ld* (05.024) are used to set up *Current Controller Kp Gain* (00.038) and *Current Controller Ki Gain* (00.039). This is only done once during the test, and so the user can make further adjustments to the current controller gains if required. To perform a Rotating autotune, set Pr **00.040** to 2, and provide the drive with both an enable signal (terminal 2 and 6) and a run signal (terminal 11 or 13).

00.041 {05.018}		Maximum Switching Frequency						
RW	Txt	RA	NC					
OL	↕	2 kHz (0), 3 kHz (1), 4 kHz (2), 6 kHz (3), 8 kHz (4), 12 kHz (5), 16 kHz (6)				⇒		8 kHz (4)
RFC-A								
RFC-S								

This parameter defines the required switching frequency. The drive may automatically reduce the actual switching frequency (without changing this parameter) if the power stage becomes too hot. A thermal model of the IGBT junction temperature is used based on the heatsink temperature and an instantaneous temperature drop using the drive output current and switching frequency. The estimated IGBT junction temperature is displayed in Pr **07.034**. If the temperature exceeds 135 °C the switching frequency is reduced if this is possible (i.e > 3 kHz). Reducing the switching frequency reduces the drive losses and the junction temperature displayed in Pr **07.034** also reduces. If the load condition persists the junction temperature may continue to rise again above 145 °C and the drive cannot reduce the switching frequency further the drive will initiate an 'OHT Inverter' trip. Every second the drive will attempt to restore the switching frequency to the level set in Pr **00.041**.

See section 8.4 *Switching frequency* on page 91, for the maximum available switching frequency for each drive rating.

## 6.4.7 Motor parameters

00.042 {05.011}		Number Of Motor Poles						
RW	Num						US	
OL	↕	Automatic (0) to 480 Poles (240)				⇒		Automatic (0)
RFC-A								
RFC-S								

### Open-loop

This parameter is used in the calculation of motor speed, and in applying the correct slip compensation. When Automatic (0) is selected, the number of motor poles is automatically calculated from the *Rated Frequency* (00.047) and the *Rated Speed rpm* (00.045). The number of poles = 120 \* rated frequency / rpm rounded to the nearest even number.

### RFC-A

This parameter must be set correctly for the vector control algorithms to operate correctly. When Automatic (0) is selected, the number of motor poles is automatically calculated from the *Rated Frequency* (00.047) and the *Rated Speed* (00.045) rpm. The number of poles = 120 \* rated frequency / rpm rounded to the nearest even number.

### RFC-S

This parameter must be set correctly for the vector control algorithms to operate correctly. When Automatic (0) is selected the number of poles is set to 6.

00.043 {05.010}		Rated Power Factor (OL)						
00.043 {03.025}		Position Feedback Phase Angle (RFC)						
RW	Num						US	
OL	↕	0.000 to 1.000				⇒		0.850
RFC-A	↕	0.000 to 1.000				⇒		0.850
RFC-S	↕	0.0 to 359.9°				⇒		0.0°

The power factor is the true power factor of the motor, i.e. the angle between the motor voltage and current.

### Open-loop

The power factor is used in conjunction with the motor rated current (Pr **00.046**) to calculate the rated active current and magnetizing current of the motor. The rated active current is used extensively to control the drive, and the magnetizing current is used in vector mode Rs compensation. It is important that this parameter is set up correctly.

This parameter is obtained by the drive during a rotational autotune. If a stationary autotune is carried out, then the nameplate value should be entered in Pr **00.043**.

#### RFC-A

If the stator inductance (Pr **05.025**) contains a non-zero value, the power factor used by the drive is continuously calculated and used in the vector control algorithms (this will not update Pr **00.043**).

If the stator inductance is set to zero (Pr **05.025**) then the power factor written in Pr **00.043** is used in conjunction with the motor rated current and other motor parameters to calculate the rated active and magnetizing currents which are used in the vector control algorithm.

This parameter is obtained by the drive during a rotational autotune. If a stationary autotune is carried out, then the nameplate value should be entered in Pr **00.043**.

#### RFC-S

The phase angle between the rotor flux in a servo motor and the encoder position is required for the motor to operate correctly. If the phase angle is known it can be set in this parameter by the user. Alternatively the drive can automatically measure the phase angle by performing a phasing test (see autotune in RFC-S mode Pr **00.040**). When the test is complete the new value is written to this parameter. The encoder phase angle can be modified at any time and becomes effective immediately. This parameter has a factory default value of 0.0°, but is not affected when defaults are loaded by the user.

00.044 {05.009} Rated Voltage		RW	Num	RA	US
OL					
RFC-A	↕		0 to VM_AC_VOLTAGE_SET	⇒	200 V drive: 230 V 50Hz default 400 V drive: 400 V 60Hz default 400 V drive: 460 V
RFC-S					

Enter the value from the rating plate of the motor.

00.045 {05.008} Rated Speed		RW	Num	US
OL	↕		0 to 33000 rpm	⇒ 50 Hz default: 1500 rpm 60 Hz default: 1800 rpm
RFC-A	↕		0.00 to 33000.00 rpm	⇒ 50 Hz default: 1450.00 rpm 60 Hz default: 1750.00 rpm
RFC-S	↕			⇒ 3000.00 rpm

#### Open-loop

This is the speed at which the motor would rotate when supplied with its base frequency at rated voltage, under rated load conditions (= synchronous speed - slip speed). Entering the correct value into this parameter allows the drive to increase the output frequency as a function of load in order to compensate for this speed drop.

Slip compensation is disabled if Pr **00.045** is set to 0 or to synchronous speed, or if Pr **05.027** is set to 0.

If slip compensation is required this parameter should be set to the value from the rating plate of the motor, which should give the correct rpm for a hot machine. Sometimes it will be necessary to adjust this when the drive is commissioned because the nameplate value may be inaccurate. Slip compensation will operate correctly both below base speed and within the field weakening region. Slip compensation is normally used to correct for the motor speed to prevent speed variation with load. The rated load rpm can be set higher than synchronous speed to deliberately introduce speed droop. This can be useful to aid load sharing with mechanically coupled motors.

#### RFC-A

Rated speed is used with motor rated frequency to determine the full load slip of the motor which is used by the vector control algorithm. Incorrect setting of this parameter can result in the following:

- Reduced efficiency of motor operation
- Reduction of maximum torque available from the motor
- Failure to reach maximum speed
- Over-current trips
- Reduced transient performance
- Inaccurate control of absolute torque in torque control modes

The nameplate value is normally the value for a hot machine, however, some adjustment may be required when the drive is commissioned if the nameplate value is inaccurate.

The rated speed rpm can be optimized by the drive (For further information, refer to section 8.1.4 *RFC-A mode* on page 84).

#### RFC-S

*Rated Speed* (00.045) is used as follows:

1. Operation without position feedback, i.e. Sensorless Mode Active (03.078) = 1.
2. Where the motor operates above this speed and flux weakening is active.
3. In the motor thermal model.

The units for *Rated Speed* (00.045) are always rpm even if a linear motor is used and *Linear Speed Select* (01.055) = 1.

00.046 {05.007} Rated Current		RW	Num	RA	US
OL					
RFC-A	↕		0.000 to VM_RATED_CURRENT	⇒	Maximum Heavy Duty Rating (00.032)
RFC-S					

Enter the name-plate value for the motor rated current.

00.047 {05.006} Rated Frequency (OL, RFC-A)		RW	Num	US
OL	↕		0.0 to 550.0 Hz	⇒ 50 Hz default: 50.0 Hz 60 Hz default: 60.0 Hz
RFC-A	↕		0.0 to 550.0 Hz	
RFC-S	↕		0 to 10000 V / 1000 rpm	⇒ 98 V / 1000 rpm

#### Open-loop and RFC-A

Enter the value from the rating plate of the motor.

### 6.4.8 Operating-mode selection

00.048 {11.031} User Drive Mode		RW	Txt	ND	NC	PT
OL				⇒		Open-loop (1)
RFC-A	↕		Open-loop (1), RFC-A (2), RFC-S (3)	⇒		RFC-A (2)
RFC-S				⇒		RFC-S (3)

The settings for Pr **00.048** are as follows:

Setting	Operating mode
1	Open-loop
2	RFC-A
3	RFC-S

This parameter defines the drive operating mode. Pr **mm.000** must be set to '1253' (European defaults) or '1254' (USA defaults) before this parameter can be changed. When the drive is reset to implement any change in this parameter, the default settings of all parameters will be

set according to the drive operating mode selected and saved in memory.

## 6.4.9 Status information

00.049 {11.044} User Security Status										
RW	Txt					ND	PT			
OL		Menu 0 (0), All Menus (1), Read-only Menu 0 (2), Read-only (3), Status Only (4), No Access (5)				⇒	Menu 0 (0)			
RFC-A	⇕					⇒				
RFC-S										

This parameter controls access via the drive keypad as follows:

Security level	Description
0 (Menu 0)	All writable parameters are available to be edited but only parameters in Menu 0 are visible.
1 (All Menus)	All writable parameters are visible and available to be edited.
2 (Read-only Menu 0)	All parameters are read-only. Access is limited to Menu 0 parameters only.
3 (Read-only)	All parameters are read-only however all menus and parameters are visible.
4 (Status Only)	The keypad remains in status mode and no parameters can be viewed or edited.
5 (No Access)	The keypad remains in status mode and no parameters can be viewed or edited. Drive parameters cannot be accessed via a comms / fieldbus interface in the drive or any option module.

The keypad can adjust this parameter even when user security is set.

00.050 {11.029} Software Version										
RO	Num					ND	NC	PT		
OL		0 to 99999999				⇒				
RFC-A	⇕					⇒				
RFC-S										

The parameter displays the software version of the drive.

00.051 {10.037} Action On Trip Detection										
RW	Bin								US	
OL		0 to 31				⇒	0			
RFC-A	⇕					⇒				
RFC-S										

Each bit in this parameter has the following functions:

Bit	Function
0	Stop on non-important trips
1	Disable braking resistor overload detection
2	Disable phase loss stop
3	Disable braking resistor temperature monitoring
4	Disable parameter freeze on trip

### Example

Pr 00.051 = 8 (1000<sub>binary</sub>) Th Brake Res trip is disabled

Pr 00.051 = 12 (1100<sub>binary</sub>) Th Brake Res and phase loss trip is disabled

### Stop on non-important trips

If bit 0 is set to one the drive will attempt to stop before tripping if any of the following trip conditions are detected: I/O Overload, An Input 1 Loss, An Input 2 Loss or Keypad Mode.

### Disable braking resistor overload detection

For details of braking resistor overload detection mode see Pr 10.030.

### Disable phase loss trip

Normally the drive will stop when the input phase loss condition is detected. If this bit is set to 1 the drive will continue to run and will only trip when the drive is brought to a stop by the user.

### Disable braking resistor temperature monitoring

Size 3, 4 and 5 drives have an internal user install braking resistor with a thermistor to detect overheating of the resistor. As default bit 3 of Pr 00.051 is set to zero, and so if the braking resistor and its thermistor is not installed the drive will produce a trip (Th Brake Res) because the thermistor appears to be open-circuit. This trip can be disabled so that the drive can run by setting bit 3 of Pr 00.051 to one. If the resistor is installed then no trip is produced unless the thermistor fails, and so bit 3 of Pr 00.051 can be left at zero. This feature only applies to size 3, 4 and 5 drives. For example if Pr 00.051 = 8, then Th Brake Res trip will be disabled.

### Disable parameter freeze on trip

If this bit is 0 then the parameters listed below are frozen on trip until the trip is cleared. If this bit is 1 then this feature is disabled.

Open-loop mode	RFC-A and RFC-S modes
Reference Selected (01.001)	Reference Selected (01.001)
Pre-skip Filter Reference (01.002)	Pre-skip Filter Reference (01.002)
Pre-ramp Reference (01.003)	Pre-ramp Reference (01.003)
Post Ramp Reference (02.001)	Post Ramp Reference (02.001)
Frequency Slaving Demand (03.001)	Final Speed Reference (03.001)
	Speed Feedback (00.010)
	Speed Error (03.003)
	Speed Controller Output (03.004)
Current Magnitude (00.012)	Current Magnitude (00.012)
Torque Producing Current (00.013)	Torque Producing Current (00.013)
Magnetising Current (04.017)	Magnetising Current (04.017)
Output Frequency (00.011)	Output Frequency (00.011)
Output Voltage (05.002)	Output Voltage (05.002)
Output Power (05.003)	Output Power (05.003)
D.c. Bus Voltage (05.005)	D.c. Bus Voltage (05.005)
Analog Input 1 (07.001)	Analog Input 1 (07.001)

00.053 {04.015} Motor Thermal Time Constant										
RW	Num								US	
OL		1.0 to 3000.0 s				⇒	89.0 s			
RFC-A	⇕					⇒				
RFC-S										

Pr 00.053 is the motor thermal time constant of the motor, and is used (along with the motor rated current Pr 00.046, and total motor current Pr 00.012) in the thermal model of the motor in applying thermal protection to the motor.

For further details, refer to section 8.3 *Motor thermal protection* on page 91.

# 7 Running the motor

This chapter takes the new user through all the essential steps to running a motor for the first time, in each of the possible operating modes.

For information on tuning the drive for the best performance, see Chapter 8 *Optimization* on page 76.



Ensure that no damage or safety hazard could arise from the motor starting unexpectedly.



The values of the motor parameters affect the protection of the motor. The default values in the drive should not be relied upon. It is essential that the correct value is entered in Pr **00.046 Rated Current**. This affects the thermal protection of the motor.



If the drive is started using the keypad it will run to the speed defined by the keypad reference (Pr **01.017**). This may not be acceptable depending on the application. The user must check in Pr **01.017** and ensure that the keypad reference has been set to 0.



If the intended maximum speed affects the safety of the machinery, additional independent over-speed protection must be used.

## 7.1 Quick start connections

### 7.1.1 Basic requirements

This section shows the basic connections which must be made for the drive to run in the required mode. For minimal parameter settings to run in each mode please see the relevant part of section 7.3 *Quick start commissioning / start-up* on page 59.

**Table 7-1 Minimum control connection requirements for each control mode**

Drive control method	Requirements
Terminal mode	Drive enable Speed / Torque reference Run forward / Run reverse
Keypad mode	Drive enable
Serial communications	Drive enable Serial communications link

**Table 7-2 Minimum control connection requirements for each mode of operation**

Operating mode	Requirements
Open loop mode	Induction motor
RFC – A mode (with speed feedback)	Induction motor with speed feedback
RFC – S mode (with speed and position feedback)	Permanent magnet motor with speed and position feedback

### Speed feedback

Suitable devices are:

- Incremental encoder (A, B or F, D with or without Z).
- Incremental encoder with forward and reverse outputs (F, R with or without Z).
- SINCOS encoder (with, or without Stegmann Hiperface, EnDat, BiSS or SSI communications protocols).
- EnDat absolute encoder.
- BiSS absolute encoder.
- Resolver.

### Speed and position feedback

Suitable devices are:

- Incremental encoder (A, B or F, D with or without Z) with commutation signals (U, V, W).
- Incremental encoder with forward and reverse outputs (F, R with or without Z) and commutation outputs (U, V, W).
- SINCOS encoder (with Stegmann Hiperface, EnDat, BiSS or SSI communications protocols)
- EnDat absolute encoder.
- BiSS absolute encoder.
- Resolver.

## 7.2 Changing the operating mode

Changing the operating mode returns all parameters to their default value, including the motor parameters. *User Security Status* (Pr **00.049**) and *User Security Code* (Pr **00.034**) are not affected by this procedure.

### Procedure

Use the following procedure only if a different operating mode is required:

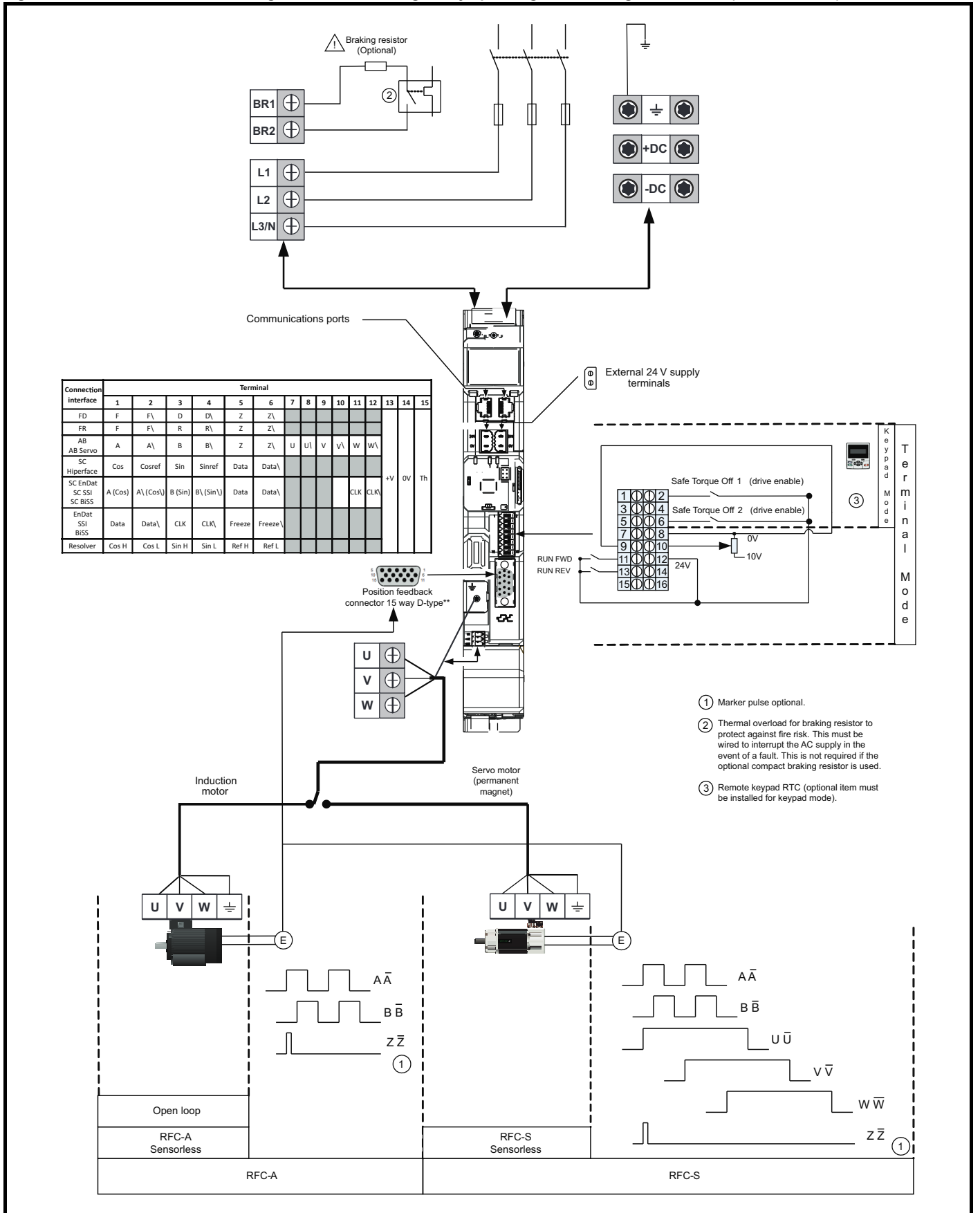
1. Enter either of the following values in Pr **mm.000**, as appropriate:  
1253 (50 Hz AC supply frequency)  
1254 (60 Hz AC supply frequency)
2. Change the setting of Pr **00.048** as follows:

Pr 00.048 setting		Operating mode
	1	Open-loop
	2	RFC-A
	3	RFC-S

The figures in the second column apply when serial communications are used.

3. Either:
  - Press the red reset button
  - Toggle the reset digital input
  - Carry out a drive reset through serial communications by setting Pr **10.038** to 100 (ensure that Pr **mm.000** returns to 0).

**Figure 7-1 Minimum connections to get the motor running in any operating mode for Digitax HD M75X (all frame sizes)**




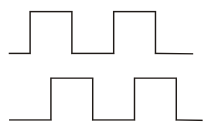
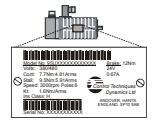
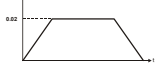
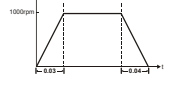




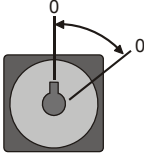


## 7.3 Quick start commissioning / start-up

### 7.3.1 RFC-S mode (with position feedback)

#### Permanent magnet motor with position feedback



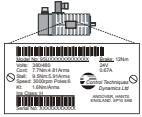
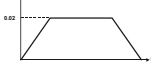
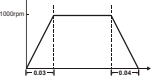
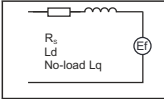


For simplicity only an incremental quadrature encoder with commutation outputs will be considered here. For information on setting up one of the other supported speed feedback devices, refer to section on page 66.

Action	Detail	
Before power-up	Ensure: <ul style="list-style-type: none"> <li>The drive enable signal is not given (terminal 2 &amp; 6).</li> <li>Run signal is not given.</li> <li>Motor and feedback device are connected.</li> </ul>	
Power-up the drive	Verify that RFC-S mode is displayed as the drive powers up. If the mode is incorrect see section 5.6 <i>KI-Remote Keypad changing the operating mode</i> on page 38. Ensure: <ul style="list-style-type: none"> <li>Drive displays 'inhibit'</li> </ul> If the drive trips, see Chapter 13 <i>Diagnostics</i> on page 217.	
Set motor feedback parameters	<b>Incremental encoder basic set-up</b> Enter: <ul style="list-style-type: none"> <li>Drive encoder type in Pr. <b>03.038</b> = AB Servo (3): Quadrature encoder with commutation outputs.</li> <li>Encoder power supply in Pr. <b>03.036</b> = 5 V (0), 8 V (1) or 15 V (2).</li> </ul> <p><b>NOTE</b></p> <p>If output voltage from the encoder is &gt;5 V, then the termination resistors must be disabled Pr <b>03.039</b> to 0.</p> <div style="border: 1px solid black; padding: 5px;">  <p>Setting the encoder voltage supply too high for the encoder could result in damage to the feedback device.</p> <p><b>CAUTION</b></p> </div> <ul style="list-style-type: none"> <li>Drive encoder Pulses Per Revolution in Pr <b>03.034</b> (set according to encoder)</li> <li>Drive encoder termination resistor setting in Pr <b>03.039</b>: <ul style="list-style-type: none"> <li><b>0</b> = A-A\, B-B\, Z-Z\ termination resistors disabled</li> <li><b>1</b> = A-A\, B-B\, termination resistors enabled, Z-Z\ termination resistors disabled</li> <li><b>2</b> = A-A\, B-B\, Z-Z\ termination resistors enabled</li> </ul> </li> </ul>	
Enter motor nameplate details	Enter: <ul style="list-style-type: none"> <li>Motor rated current in Pr <b>00.046</b> (A)</li> <li>Ensure that this equal to or less than the Heavy Duty rating of the drive otherwise 'Motor Too Hot' trips may occur during the autotune.</li> <li>Number of poles in Pr <b>00.042</b></li> <li>Motor rated voltage in Pr <b>00.044</b> (V)</li> </ul>	
Set maximum speed	Enter: <ul style="list-style-type: none"> <li>Maximum speed in Pr <b>00.002</b> (rpm)</li> </ul>	
Set acceleration / deceleration rates	Enter: <ul style="list-style-type: none"> <li>Acceleration rate in Pr <b>00.003</b> (s/1000 rpm)</li> <li>Deceleration rate in Pr <b>00.004</b> (s/1000 rpm) (If braking resistor installed, set Pr <b>00.015</b> = Fast. Also ensure Pr <b>10.030</b>, Pr <b>10.031</b> and Pr <b>10.061</b> are set correctly, otherwise premature 'Brake R Too Hot' trips may be seen).</li> </ul>	
Motor thermistor set-up	The motor thermistor connection is made through the drive encoder port (terminal 15). The thermistor type is selected in <i>P1 Thermistor Type</i> (03.118). Motor thermistor fault detection is enabled as default, it can be deselected in Pr <b>03.123</b> . Refer to Pr <b>03.123</b> for further information.	

Action	Detail	
Autotune	<p>The drive is able to perform either a stationary or a rotating autotune. The motor must be at a standstill before an autotune is enabled. A stationary autotune will give moderate performance whereas a rotating autotune will give improved performance as it measures the actual values of the motor parameters required by the drive. The drive is able to perform a stationary, rotating, mechanical load measurement or locked rotor test autotune. The motor must be at a standstill before an autotune is enabled. It is suggested that a rotating auto tune is used for accurate measurement for position feedback phase angle.</p> <ul style="list-style-type: none"> <li>A stationary autotune can be used when the motor is loaded and it is not possible to uncouple the load from the motor shaft. A stationary autotune is performed to locate the flux axis of the motor. The stationary autotune measures the stator resistance, inductance in flux axis, maximum deadtime compensation, inductance in torque axis with no load on the motor and current at maximum deadtime compensation of the motor. These are used to calculate the current loop gains, and at the end of the test the values in Pr <b>00.038</b> and Pr <b>00.039</b> are updated. If Sensorless mode is not selected then <i>Position Feedback Phase Angle</i> (00.043) is set-up for the selected position feedback.</li> <li>A rotating autotune should only be used if the motor is uncoupled. The rotating autotune will rotate the motor by up to 2 mechanical revolutions in the direction selected, regardless of the reference provided to obtain the position feedback phase angle. A stationary autotune is then performed to obtain stator resistance, inductance in flux axis, maximum deadtime compensation, inductance in torque axis with no load on the motor and current at maximum deadtime compensation of the motor. From the above obtained parameters the current loop gains are calculated, and at the end of the test the values in Pr <b>00.038</b> and Pr <b>00.039</b> are updated.</li> </ul> <div style="border: 1px solid black; padding: 5px;">  <p>The rotating autotune will rotate the motor by up to 2 mechanical revolutions in the direction selected, regardless of the reference provided. After a short delay, the motor is further rotated through a electrical revolution. The enable signal must be removed before the drive can be made to run at the required reference. The drive can be stopped at any time by removing the run signal or removing the drive enable.</p> </div> <p>To perform an autotune:</p> <ul style="list-style-type: none"> <li>Set Pr <b>00.040</b> = 1 for a stationary autotune, Pr <b>00.040</b> = 2 for a rotating autotune.</li> <li>Close the run signal (terminal 11 or 13).</li> <li>Close the drive enable signal (terminal 2 &amp; 6).</li> </ul> <p>The upper row of the display will flash 'Auto Tune' while the drive is performing the test.</p> <ul style="list-style-type: none"> <li>Wait for the drive to display 'Ready' or 'Inhibit' and for the motor to come to a standstill.</li> </ul> <p>If the drive trips it cannot be reset until the drive enable signal (terminal 2 &amp; 6) has been removed. See section 13 <i>Diagnostics</i> on page 217.</p> <ul style="list-style-type: none"> <li>Remove the drive enabled and run signal from the drive.</li> </ul>	
Save parameters	Select 'Save Parameters' in Pr <b>MM.000</b> (alternatively enter a value of 1001 in Pr <b>MM.000</b> ) and press red 	
Run	Drive is now ready to run	

### 7.3.2 RFC-S mode (Sensorless control)

#### Permanent magnet motor without position feedback

Action	Detail	
Before power-up	Ensure: <ul style="list-style-type: none"> <li>The drive enable signal is not given (terminal 2 &amp; 6).</li> <li>Run signal is not given</li> <li>Motor is connected</li> </ul>	
Power-up the drive	Verify that RFC-S mode is displayed as the drive powers up. If the mode is incorrect see section 5.6 <i>KI-Remote Keypad changing the operating mode</i> on page 38, otherwise restore parameter defaults (see section 5.8 <i>Restoring parameter defaults</i> on page 38). Ensure: <ul style="list-style-type: none"> <li>Drive displays 'inhibit'</li> </ul> If the drive trips, see Chapter 13 <i>Diagnostics</i> on page 217.	
Select RFC-S (Sensorless control) mode and disable encoder wirebreak trip	<ul style="list-style-type: none"> <li>Set Pr <b>03.024</b> = 1 or 3 to select RFC-S Sensorless mode.</li> <li>Set Pr <b>03.040</b> = 0000 to disable the wire break.</li> </ul>	
Enter motor nameplate details	Enter: <ul style="list-style-type: none"> <li>Motor rated current in Pr <b>00.046</b> (A) Ensure that this equal to or less than the Heavy Duty rating of the drive otherwise 'Motor Too Hot' trips may occur during the autotune.</li> <li>Number of poles in Pr <b>00.042</b></li> <li>Motor rated voltage in Pr <b>00.044</b> (V)</li> </ul>	
Set maximum speed	Enter: <ul style="list-style-type: none"> <li>Maximum speed in Pr <b>00.002</b> (rpm)</li> </ul>	
Set acceleration / deceleration rates	Enter: <ul style="list-style-type: none"> <li>Acceleration rate in Pr <b>00.003</b> (s/1000 rpm). It is recommended that the ramp rates are increased from the default value of 0.200 s/1000 rpm.</li> <li>Deceleration rate in Pr <b>00.004</b> (s/1000 rpm) (If braking resistor installed, set Pr <b>00.015</b> = Fast. Also ensure Pr <b>10.030</b>, Pr <b>10.031</b> and Pr <b>10.061</b> are set correctly, otherwise premature 'Brake R Too Hot' trips may be seen).</li> </ul>	
Set stop mode	Enter: <ul style="list-style-type: none"> <li>Set Stop Mode to Ramp in Pr <b>06.001</b></li> </ul>	
Set hold zero speed	Enter: <ul style="list-style-type: none"> <li>Set Hold Zero Speed to Off (0) in Pr <b>06.008</b>.</li> </ul>	
Autotune	<p>The drive is able to perform a stationary autotune. The motor must be at a standstill before an autotune is enabled. A stationary autotune will give moderate performance.</p> <ul style="list-style-type: none"> <li>A stationary autotune is performed to locate the flux axis of the motor. The stationary autotune measures the stator resistance, inductance in flux axis, inductance in torque axis with no load on the motor and values relating to deadtime compensation from the drive. Measured values are used to calculate the current loop gains, and at the end of the test the values in Pr <b>00.038</b> and Pr <b>00.039</b> are updated.</li> </ul> <p>To perform an autotune:</p> <ul style="list-style-type: none"> <li>Set Pr <b>00.040</b> = 1 or 2 for a stationary autotune. (Both perform the same tests).</li> <li>Close the run signal (terminal 11 or 13).</li> <li>Close the drive enable signal (terminal 2 &amp; 6).</li> </ul> <p>The upper row of the display will flash 'Auto Tune' while the drive is performing the test.</p> <ul style="list-style-type: none"> <li>Wait for the drive to display 'Ready' or 'Inhibit' and for the motor to come to a standstill.</li> </ul> <p>If the drive trips it cannot be reset until the drive enable signal (terminal 2 &amp; 6) has been removed. See Chapter 13 <i>Diagnostics</i> on page 217.</p> <ul style="list-style-type: none"> <li>Remove the drive enabled and run signal from the drive.</li> </ul>	
Check Saliency	<p>In sensorless mode, when the motor speed is below Pr <b>00.045</b> / 10, a special low speed algorithm must be used to control the motor. There are two modes available, with the mode chosen based on the saliency of the motor.</p> <p>The ratio No-load Lq (Pr <b>00.056</b>) / Ld (Pr <b>05.024</b>) provides a measure of the saliency. If this value is &gt; 1.1, then Injection (0) mode may be used. Current (2) mode may be used (but with limitations). If this value is &lt; 1.1, then Current (2) mode must be used (this is the default of Pr <b>05.064</b>).</p>	
Save parameters	Select 'Save Parameters' in Pr <b>mm.000</b> (alternatively enter a value of 1001 in Pr <b>mm.000</b> ) and press red  reset button or toggle the reset digital input.	
Run	Drive is now ready to run	




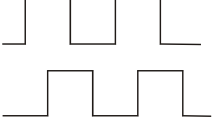
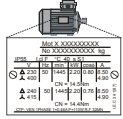

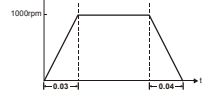


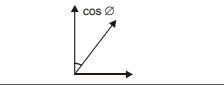
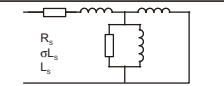
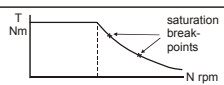
### 7.3.3 Open loop



Action	Detail	
Before power-up	Ensure: <ul style="list-style-type: none"> <li>The drive enable signal is not given (terminal 2 &amp; 6).</li> <li>Run signal is not given</li> <li>Motor is connected</li> </ul>	
Power-up the drive	Verify that Open Loop mode is displayed as the drive powers up. If the mode is incorrect see section 5.6 <i>KI-Remote Keypad changing the operating mode</i> on page 38. Ensure: <ul style="list-style-type: none"> <li>Drive displays 'Inhibit'</li> </ul> If the drive trips, see section 13 <i>Diagnostics</i> on page 217.	
Enter motor nameplate details	Enter: <ul style="list-style-type: none"> <li>Motor rated frequency in Pr <b>00.047</b> (Hz)</li> <li>Motor rated current in Pr <b>00.046</b> (A)</li> <li>Motor rated speed in Pr <b>00.045</b> (rpm)</li> <li>Motor rated voltage in Pr <b>00.044</b> (V) - check if <math>\Delta</math> or <math>\lambda</math> connection</li> </ul>	
Set maximum frequency	Enter: <ul style="list-style-type: none"> <li>Maximum frequency in Pr <b>00.002</b> (Hz)</li> </ul>	
Set acceleration / deceleration rates	Enter: <ul style="list-style-type: none"> <li>Acceleration rate in Pr <b>00.003</b> (s/100 Hz)</li> <li>Deceleration rate in Pr <b>00.004</b> (s/100 Hz) (If braking resistor installed, set Pr <b>00.015</b> = Fast. Also ensure Pr <b>10.030</b> and Pr <b>10.031</b> and Pr <b>10.061</b> are set correctly, otherwise premature 'Brake R Too Hot' trips may be seen).</li> </ul>	
Motor thermistor set-up	The motor thermistor connection is made through the drive encoder port (terminal 15). The thermistor type is selected in <i>P1 Thermistor Type</i> (03.118). The motor thermistor can be selected in Pr <b>03.123</b> . Refer to Pr <b>03.123</b> for further information.	
Autotune	<p>The drive is able to perform either a stationary or a rotating autotune. The motor must be at a standstill before an autotune is enabled. A rotating autotune should be used whenever possible so the measured value of power factor of the motor is used by the drive.</p> <div style="border: 1px solid black; padding: 5px;"> <p><b>WARNING</b> A rotating autotune will cause the motor to accelerate up to <math>\frac{2}{3}</math> base speed in the direction selected regardless of the reference provided. Once complete the motor will coast to a stop. The enable signal must be removed before the drive can be made to run at the required reference. The drive can be stopped at any time by removing the run signal or removing the drive enable.</p> </div> <ul style="list-style-type: none"> <li>A stationary autotune can be used when the motor is loaded and it is not possible to uncouple the load from the motor shaft. A stationary autotune measures the stator resistance and the transient inductance in the motor. These are required for good performance in vector control modes. A stationary autotune does not measure the power factor of the motor so the value on the motor nameplate must be entered into Pr <b>00.043</b>.</li> <li>A rotating autotune should only be used if the motor is uncoupled. A rotating autotune first performs a stationary autotune before rotating the motor at <math>\frac{2}{3}</math> base speed in the direction selected. The rotating autotune measures the power factor of the motor.</li> </ul> <p>To perform an autotune:</p> <ul style="list-style-type: none"> <li>Set Pr <b>00.040</b> = 1 for a stationary autotune or set Pr <b>00.040</b> = 2 for a rotating autotune</li> <li>Close the Drive Enable signal (terminal 2 &amp; 6). The drive will display 'Ready'.</li> <li>Close the run signal (terminal 11 or 13). The upper row of the display will flash 'Auto Tune' while the drive is performing the autotune.</li> <li>Wait for the drive to display 'Ready' or 'Inhibit' and for the motor to come to a standstill.</li> </ul> <p>If the drive trips, see Chapter 13 <i>Diagnostics</i> on page 217.</p> <ul style="list-style-type: none"> <li>Remove the drive enable and run signal from the drive.</li> </ul>	
Save parameters	Select 'Save Parameters' in Pr <b>mm.000</b> (alternatively enter a value of 1001 in Pr <b>mm.000</b> ) and press the red  reset button or toggle the reset digital input.	
Run	Drive is now ready to run	

### 7.3.4 RFC - A mode (with position feedback)

#### Induction motor with position feedback

For simplicity only an incremental quadrature encoder will be considered here. For information on setting up one of the other supported speed feedback devices, refer to section on page 66.



Action	Detail	
Before power-up	Ensure: <ul style="list-style-type: none"> <li>The drive enable signal is not given (terminal 2 &amp; 6).</li> <li>Run signal is not given</li> <li>Motor and feedback device are connected</li> </ul>	
Power-up the drive	Verify that RFC-A mode is displayed as the drive powers up. If the mode is incorrect see section 5.6 <i>KI-Remote Keypad changing the operating mode</i> on page 38. Ensure: <ul style="list-style-type: none"> <li>Drive displays 'Inhibit'</li> </ul> If the drive trips, see Chapter 13 <i>Diagnostics</i> on page 217.	
Set motor feedback parameters	<b>Incremental encoder basic set-up</b> Enter: <ul style="list-style-type: none"> <li>Drive encoder type in Pr <b>03.038</b> = AB (0): Quadrature encoder</li> <li>Encoder power supply in Pr. <b>03.036</b> = 5 V (0), 8 V (1) or 15 V (2).</li> </ul> <b>NOTE</b> If output voltage from the encoder is >5 V, then the termination resistors must be disabled Pr <b>03.039</b> to 0.   Setting the encoder voltage supply too high for the encoder could result in damage to the feedback device. <b>CAUTION</b> <ul style="list-style-type: none"> <li>Drive encoder Lines Per Revolution (LPR) in Pr <b>03.034</b> (set according to encoder)</li> <li>Drive encoder termination resistor setting in Pr <b>03.039</b>: <ul style="list-style-type: none"> <li><b>0</b> = A-A\, B-B\, Z-Z\ termination resistors disabled</li> <li><b>1</b> = A-A\, B-B\, termination resistors enabled, Z-Z\ termination resistors disabled</li> <li><b>2</b> = A-A\, B-B\, Z-Z\ termination resistors enabled</li> </ul> </li> </ul>	
Enter motor nameplate details	<ul style="list-style-type: none"> <li>Motor rated frequency in Pr <b>00.047</b> (Hz)</li> <li>Motor rated current in Pr <b>00.046</b> (A)</li> <li>Motor rated speed in Pr <b>00.045</b> (rpm)</li> <li>Motor rated voltage in Pr <b>00.044</b> (V) - check if <math>\Delta</math> or <math>\Lambda</math> connection</li> </ul>	
Set maximum speed	Enter: Maximum speed in Pr <b>00.002</b> (rpm)	
Set acceleration / deceleration rates	Enter: <ul style="list-style-type: none"> <li>Acceleration rate in Pr <b>00.003</b> (s/1000 rpm)</li> <li>Deceleration rate in Pr <b>00.004</b> (s/1000 rpm) (If braking resistor installed, set Pr <b>00.015</b> = Fast. Also ensure Pr <b>10.030</b>, Pr <b>10.031</b> and Pr <b>10.061</b> are set correctly, otherwise premature 'Brake R Too Hot' trips may be seen).</li> </ul>	
Motor thermistor set-up	The motor thermistor connection is made through the drive encoder port (terminal 15). The thermistor type is selected in <i>P1 Thermistor Type</i> (03.118). The motor thermistor can be selected in Pr <b>03.123</b> . Refer to Pr <b>03.123</b> for further information.	
Autotune	The drive is able to perform either a stationary or a rotating autotune. The motor must be at a standstill before an autotune is enabled. A stationary autotune will give moderate performance whereas a rotating autotune will give improved performance as it measures the actual values of the motor parameters required by the drive.   A rotating autotune will cause the motor to accelerate up to $2/3$ base speed in the direction selected regardless of the reference provided. Once complete the motor will coast to a stop. The enable signal must be removed before the drive can be made to run at the required reference. <b>WARNING</b> The drive can be stopped at any time by removing the run signal or removing the drive enable. <ul style="list-style-type: none"> <li>A stationary autotune can be used when the motor is loaded and it is not possible to uncouple the load from the motor shaft. The stationary autotune measures the stator resistance and transient inductance of the motor. These are used to calculate the current loop gains, and at the end of the test the values in Pr <b>00.038</b> and Pr <b>00.039</b> are updated. A stationary autotune does not measure the power factor of the motor so the value on the motor nameplate must be entered into Pr <b>00.043</b>.</li> <li>A rotating autotune should only be used if the motor is uncoupled. A rotating autotune first performs a stationary autotune before rotating the motor at <math>2/3</math> base speed in the direction selected. The rotating autotune measures the stator inductance of the motor and calculates the power factor.</li> </ul> To perform an autotune: <ul style="list-style-type: none"> <li>Set Pr <b>00.040</b> = 1 for a stationary autotune or set Pr <b>00.040</b> = 2 for a rotating autotune</li> <li>Close the drive enable signal (terminal 2 &amp; 6). The drive will display 'Ready'.</li> <li>Close the run signal (terminal 11 or 13). The upper row of the display will flash 'Auto Tune' while the drive is performing the autotune.</li> <li>Wait for the drive to display 'Ready' or 'Inhibit' and for the motor to come to a standstill</li> </ul> If the drive trips, see Chapter 13 <i>Diagnostics</i> on page 217. <ul style="list-style-type: none"> <li>Remove the drive enable and run signal from the drive.</li> </ul>	  

Action	Detail	
Save parameters	Select 'Save Parameters' in Pr <b>mm.000</b> (alternatively enter a value of 1001 in Pr <b>mm.000</b> ) and press red  reset button or toggle the reset digital input.	
Run	Drive is now ready to run	

### 7.3.5 RFC-A mode (Sensorless control)

#### Induction motor with sensorless control

Action	Detail	
Before power-up	Ensure: <ul style="list-style-type: none"> <li>The drive enable signal is not given (terminal 2 &amp; 6).</li> <li>Run signal is not given</li> <li>Motor is connected</li> </ul>	
Power-up the drive	Verify that RFC-A mode is displayed as the drive powers up. If the mode is incorrect see section 5.6 <i>KI-Remote Keypad changing the operating mode</i> on page 38. Ensure: <ul style="list-style-type: none"> <li>Drive displays 'Inhibit'</li> </ul> If the drive trips, see Chapter 13 <i>Diagnostics</i> on page 217.	
Select RFC-A (Sensorless control) mode and disable wire-encoder wire-break trip	<ul style="list-style-type: none"> <li>Set Pr <b>03.024</b> = 1 or 3 to select RFC-A Sensorless mode</li> <li>Set Pr <b>03.040</b> = 0000 to disable the wire break</li> </ul>	
Enter motor nameplate details	Enter: <ul style="list-style-type: none"> <li>Motor rated frequency in Pr <b>00.047</b> (Hz)</li> <li>Motor rated current in Pr <b>00.046</b> (A)</li> <li>Motor rated speed in Pr <b>00.045</b> (rpm)</li> <li>Motor rated voltage in Pr <b>00.044</b> (V) - check if <math>\Delta</math> or <math>\text{Y}</math> connection</li> </ul>	
Set maximum speed	Enter: <ul style="list-style-type: none"> <li>Maximum speed in Pr <b>00.002</b> (rpm)</li> </ul>	
Set acceleration / deceleration rates	Enter: <ul style="list-style-type: none"> <li>Acceleration rate in Pr <b>00.003</b> (s/1000rpm)</li> <li>Deceleration rate in Pr <b>00.004</b> (s/1000rpm) (If braking resistor installed, set Pr <b>00.015</b> = Fast. Also ensure Pr <b>10.030</b>, Pr <b>10.031</b> and Pr <b>10.061</b> are set correctly, otherwise premature 'Brake R Too Hot' trips may be seen).</li> </ul>	
Motor thermistor set-up	The motor thermistor connection is made through the drive encoder port (terminal 15). The thermistor type is selected in <i>P1 Thermistor Type</i> (03.118). The motor thermistor can be selected in Pr <b>03.123</b> . Refer to Pr <b>03.123</b> for further information.	
Select or deselect catch a spinning motor mode	If catch a spinning motor mode is not required then set Pr <b>06.009</b> to 0. If catch a spinning motor mode is required then leave Pr <b>06.009</b> at the default of 1, but depending on the size of the motor the value in Pr <b>05.040</b> may need to be adjusted. Pr <b>05.040</b> defines a scaling function used by the algorithm that detects the speed of the motor. The default value of Pr <b>05.040</b> is 1 which is suitable for small motors (< 4 kW). For larger motors the value in Pr <b>05.040</b> will need to be increased. Approximate values of Pr <b>05.040</b> for different motor sizes are as follows, 2 for 11 kW, 3 for 55 kW and 5 for 150 kW. If the value of Pr <b>05.040</b> is too large the motor may accelerate from standstill when the drive is enabled. If the value of this parameter is too small the drive will detect the motor speed as zero even if the motor is spinning.	
Autotune	<p>The drive is able to perform either a stationary or a rotating autotune. The motor must be at a standstill before an autotune is enabled. A stationary autotune will give moderate performance whereas a rotating autotune will give improved performance as it measures the actual values of the motor parameters required by the drive.</p> <p><b>NOTE</b> It is highly recommended that a rotating autotune is performed (Pr <b>00.040</b> set to 2).</p> <div style="border: 1px solid black; padding: 5px;"> <p><b>WARNING</b> A rotating autotune will cause the motor to accelerate up to <math>2/3</math> base speed in the direction selected regardless of the reference provided. Once complete the motor will coast to a stop. The enable signal must be removed before the drive can be made to run at the required reference. The drive can be stopped at any time by removing the run signal or removing the drive enable.</p> </div> <ul style="list-style-type: none"> <li>A stationary autotune can be used when the motor is loaded and it is not possible to uncouple the load from the motor shaft. The stationary autotune measures the stator resistance and transient inductance of the motor. These are used to calculate the current loop gains, and at the end of the test the values in Pr <b>00.038</b> and Pr <b>00.039</b> are updated. A stationary autotune does not measure the power factor of the motor so the value on the motor nameplate must be entered into Pr <b>00.043</b>.</li> <li>A rotating autotune should only be used if the motor is uncoupled. A rotating autotune first performs a stationary autotune before rotating the motor at <math>2/3</math> base speed in the direction selected. The rotating autotune measures the stator inductance of the motor and calculates the power factor.</li> </ul> <p>To perform an autotune:</p> <ul style="list-style-type: none"> <li>Set Pr <b>00.040</b> = 1 for a stationary autotune or set Pr <b>00.040</b> = 2 for a rotating autotune</li> <li>Close the drive enable signal (terminal 2 &amp; 6). The drive will display 'Ready' or 'Inhibit'.</li> <li>Close the run signal (terminal 11or13). The upper row of the display will flash 'Auto Tune' while the drive is performing the autotune.</li> <li>Wait for the drive to display 'Ready' or 'Inhibit' and for the motor to come to a standstill.</li> </ul> <p>If the drive trips, see Chapter 13 <i>Diagnostics</i> on page 217.</p> <ul style="list-style-type: none"> <li>Remove the drive enable and run signal from the drive.</li> </ul>	

Action	Detail	
Save parameters	Select 'Save Parameters' in Pr <b>MM.000</b> (alternatively enter a value of 1001 in Pr <b>MM.000</b> ) and press red  reset button or toggle the reset digital input.	
Run	Drive is now ready to run	

## 7.4 Quick start commissioning / start-up using Connect

Connect is a Windows™ based software commissioning / start-up tool for Digitax HD.

Connect can be downloaded from <http://www.drive-setup.com/ctdownloads>

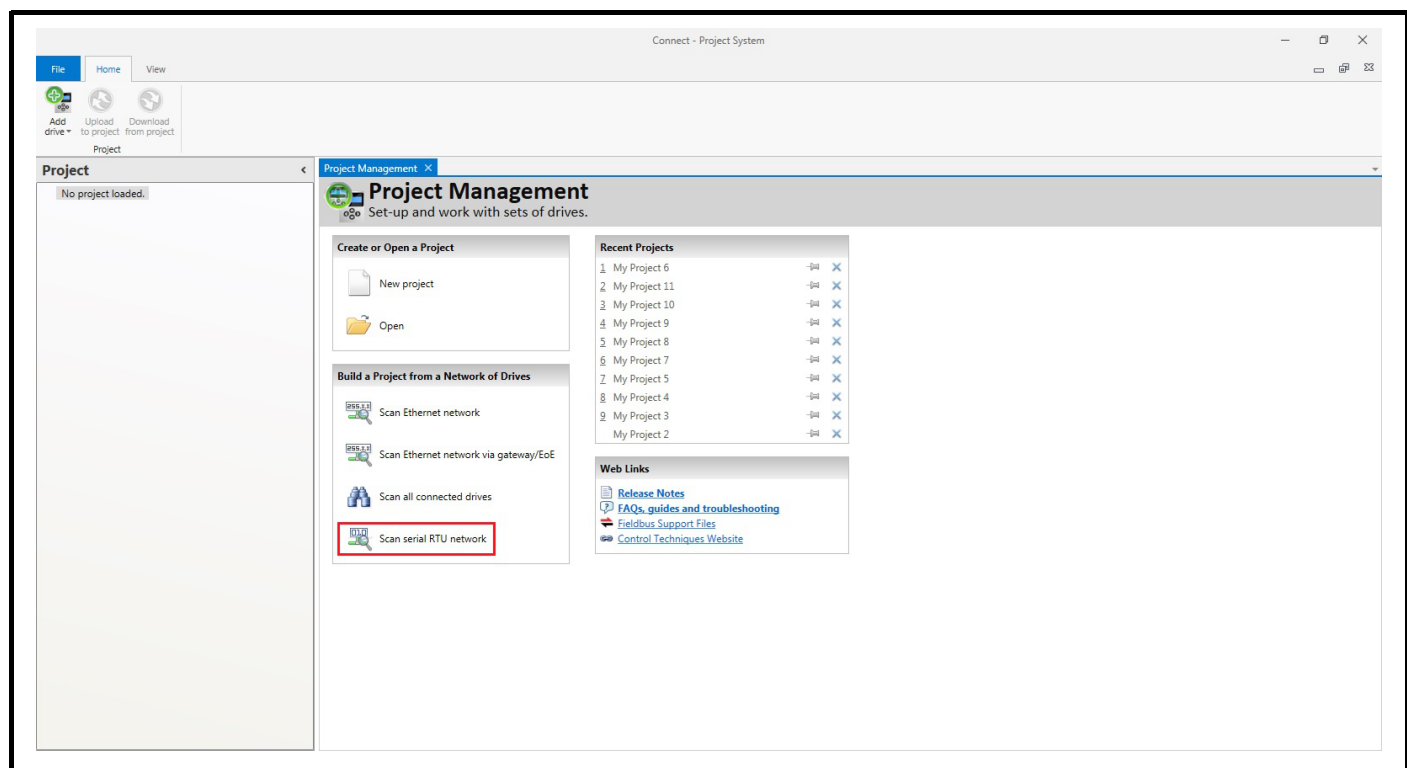
### Connect system requirements

- Windows 8, Windows 7 SP1, Windows Vista SP2, Windows XP SP3
- Minimum of 1280 x 1024 screen resolution with 256 colours
- Microsoft.Net Frameworks 4.0 (this is provided in the downloaded file)
- Note that you must have administrator rights to install Connect

Any previous copy of Connect should be uninstalled before proceeding with the installation (existing projects will not be lost).

### 7.4.1 Power-up the drive

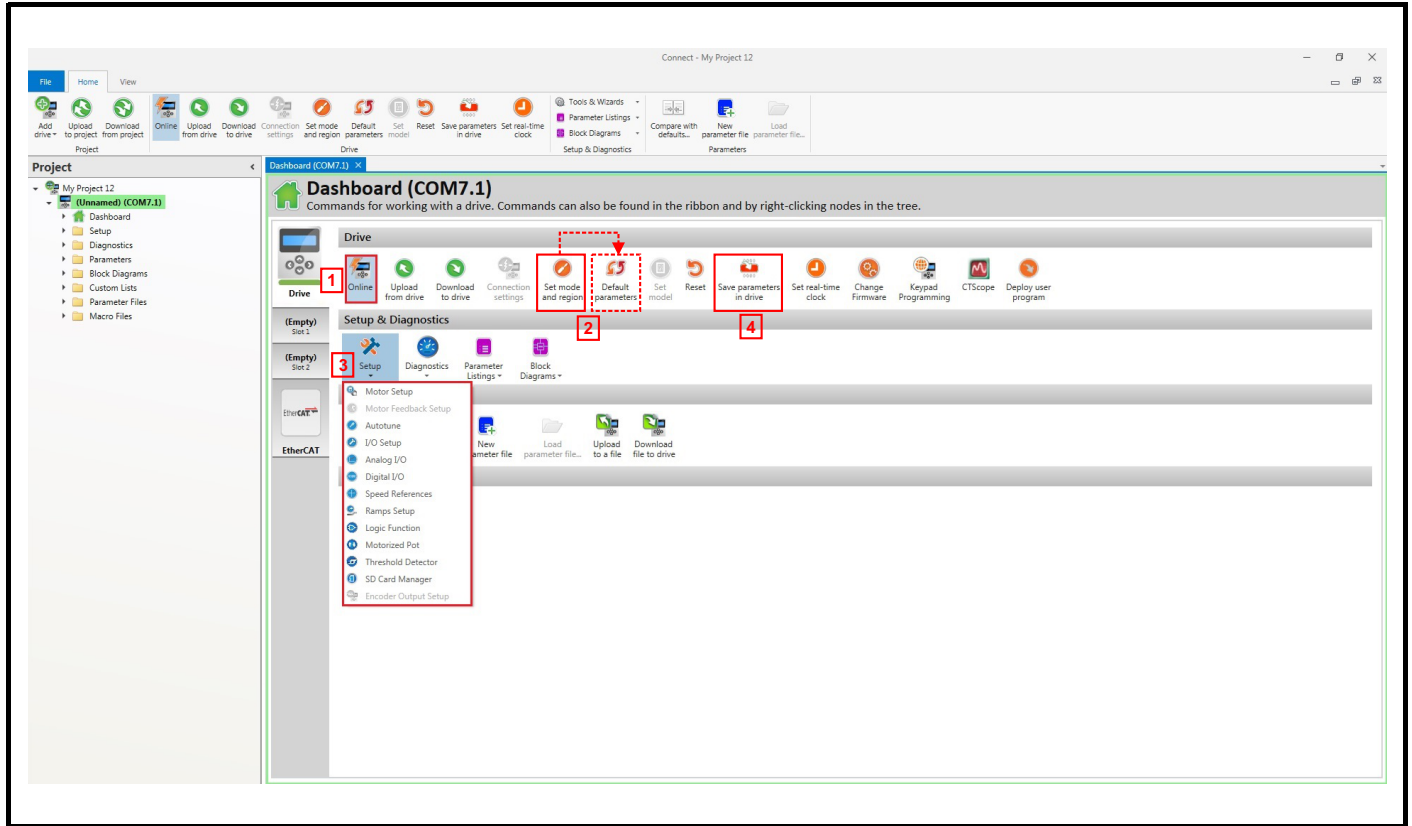
1. Start Connect, and on the 'Project Management' screen select 'Scan serial RTU network' (M751 only when connected to the drive communication port or all variants when connecting via the KI-Compact 485 adaptor), 'Scan Ethernet network' (M750 only or M753 when using Ethernet over EtherCAT protocol) or 'Scan all connected drives'. This example uses the 'Scan serial RTU network' option.




Select the discovered drive.

1. Select the 'Online' icon to connect with the drive. When a successful connection is made the icon will be highlighted blue.
2. Select 'Set mode and region'.  
If the required control mode is highlighted in the 'Drive Settings' dialog, then:
  - Change the supply frequency if required and select 'Apply', otherwise select 'Cancel'.
 If the required control mode is not highlighted in the 'Drive Settings' dialog then:
  - Select the required mode and supply frequency.
  - Select 'Apply'.

Select 'Default parameters' from the Dashboard and in the 'Default Parameters' dialog, select 'Apply'.



3. Select 'Setup' and perform the steps highlighted:

Action	Detail
Motor set-up	Connect contains a database for induction motors and permanent magnet motors. Provision is also made to enter motor nameplate data.
Motor feedback set-up	<p>This only needs to be performed in RFC-S and RFC-A (with feedback) modes. Enter the encoder type and encoder configuration data as prompted on screen.</p> <p><b>NOTE</b></p> <p>If output voltage from the encoder is &gt; 5 V, then the termination resistors must be disabled Pr <b>03.039</b> to 0.</p> <div style="border: 1px solid black; padding: 5px;">  <p>Setting the encoder voltage supply too high for the encoder could result in damage to the feedback device.</p> <p><b>CAUTION</b></p> </div>
Speed references	Enter preset speeds or a jog reference if required.
Ramps set-up	Enter the required Acceleration rate and Deceleration rate. Note: If a braking resistor is installed, set 'Ramp mode' to 'Fast'. Also ensure Pr <b>10.030</b> and Pr <b>10.031</b> and Pr <b>10.061</b> are set correctly, otherwise premature 'Brake R Too Hot' trips may be seen.
I/O set-up	Map I/O terminals to parameters (where non default configuration is required).
Analog I/O	Configure Analog input 1 and thermal monitoring parameters (where non default configuration is required).
Digital I/O	Allocate non default digital control functions to digital terminals where necessary.
Autotune	Follow the Autotune set up wizard to automatically tune the drive to the motor.

4. Select 'Save parameters in drive' to perform a parameter save. The drive is now ready to run.

## 7.5 Setting up a feedback device

### 7.5.1 P1 position interface

This section shows the parameter settings which must be made to use each of the compatible feedback device types with P1 position interface on the drive. For more information on the parameters listed here please refer to the *Parameter Reference Guide*.

**Table 7-3 Parameters required for feedback device set-up on the P1 position interface**

Parameter	AB, FD, FR, AB Servo, SC, SC Servo, SC SC FD Servo, FR Servo	SC Hiperface	SC EnDat	SC BiSS	SC SSI	SSI	EnDat	BiSS	Resolver
P1 Marker Mode (03.031)	✓								
P1 Rotary Turns Bits (03.033)		•	•	•	✓	✓	•	•	
P1 Rotary Lines Per Revolution (03.034)	✓	•	•	•	✓				
P1 Comms Bits (03.035)		•	•	•	✓	✓	•	•	
P1 Supply Voltage (03.036)*	✓	✓	✓	✓	✓	✓	✓	✓	
P1 Comms Baud Rate (03.037)			✓	✓	✓	✓	✓	✓	
P1 Device Type (03.038)	✓	✓	✓	✓	✓	✓	✓	✓	✓
P1 Auto-configuration Select (03.041)		✓	✓	✓			✓	✓	
P1 SSI Binary Mode (03.048)					✓	✓			
P1 Calculation time (03.060)							✓	✓	
P1 Resolver Poles (03.065)									✓
P1 Resolver Excitation (03.066)									✓
P1 Additional Configuration (03.074)				•				•	

✓ Information required to be entered by the user.

• Parameter can be set-up automatically by the drive through auto-configuration parameter. Must be set by the user if auto-configuration is disabled (i.e. Pr **03.041** = Disabled (0)).

\* Pr **03.036**: If the output voltage from the encoder is > 5 V, then termination resistors must be disabled by setting Pr **03.039** to 0.

Table 7-3 shows a summary of the parameters required to set-up each feedback device. More detailed information follows.

### 7.5.2 P1 position interface: Detailed feedback device commissioning / start-up information

Standard quadrature encoder with or without commutation signals (A, B, Z or A, B, Z, U, V, W), or  
 Sincos encoder with or without UVW commutation signals  
 Sincos encoder with absolute position from single sin and cosine signals

<i>Device Type</i> (03.038)	<b>AB</b> (0) for a quadrature encoder without commutation signals * <b>AB Servo</b> (3) for a quadrature encoder with commutation signals <b>SC</b> (6) for a Sincos encoder without commutation signals * <b>SC Servo</b> (12) for a Sincos encoder with commutation signals <b>SC SC</b> (15) for a Sincos encoder with absolute position from single sin and cosine signals																													
<i>Supply Voltage</i> (03.036)	<b>5 V</b> (0), <b>8 V</b> (1) or <b>15 V</b> (2) <b>NOTE</b> If output voltage from the encoder is >5 V, then the termination resistors must be disabled. Set Pr <b>03.039</b> to 0																													
<i>Rotary Line Per Revolution</i> (03.034)	Set to the number of lines or sine waves per revolution of the encoder.																													
<i>Termination Select</i> (03.039) (AB or AB Servo only)	<b>0</b> = A, B, Z termination resistors disabled <b>1</b> = A, B termination resistors enabled and Z termination resistors disabled <b>2</b> = A, B, Z termination resistors enabled																													
<i>Marker Mode</i> (03.031)	<table border="1"> <thead> <tr> <th colspan="4">Bit</th> <th rowspan="2">Description</th> </tr> <tr> <th>3</th> <th>2</th> <th>1</th> <th>0</th> </tr> </thead> <tbody> <tr> <td>x</td> <td>x</td> <td>x</td> <td>1</td> <td>No action is taken unless marker flag is zero before marker event occurs</td> </tr> <tr> <td>x</td> <td>x</td> <td>1</td> <td>x</td> <td>Pr <b>03.028</b> and Pr <b>03.058</b> are set to zero</td> </tr> <tr> <td>x</td> <td>1</td> <td>x</td> <td>x</td> <td>Pr <b>03.028</b>, Pr <b>03.029</b>, Pr <b>03.030</b> and the related part of Pr <b>03.058</b> are not reset. Pr <b>03.058</b> is transferred to Pr <b>03.059</b> and Pr <b>03.032</b> is set to 1.</td> </tr> <tr> <td>1</td> <td>x</td> <td>x</td> <td>x</td> <td>Undefined state region range is reduced from -30 mV to 30 mV. The marker pulse is only recognized if the pulse is 10 μs wide.</td> </tr> </tbody> </table>	Bit				Description	3	2	1	0	x	x	x	1	No action is taken unless marker flag is zero before marker event occurs	x	x	1	x	Pr <b>03.028</b> and Pr <b>03.058</b> are set to zero	x	1	x	x	Pr <b>03.028</b> , Pr <b>03.029</b> , Pr <b>03.030</b> and the related part of Pr <b>03.058</b> are not reset. Pr <b>03.058</b> is transferred to Pr <b>03.059</b> and Pr <b>03.032</b> is set to 1.	1	x	x	x	Undefined state region range is reduced from -30 mV to 30 mV. The marker pulse is only recognized if the pulse is 10 μs wide.
Bit				Description																										
3	2	1	0																											
x	x	x	1	No action is taken unless marker flag is zero before marker event occurs																										
x	x	1	x	Pr <b>03.028</b> and Pr <b>03.058</b> are set to zero																										
x	1	x	x	Pr <b>03.028</b> , Pr <b>03.029</b> , Pr <b>03.030</b> and the related part of Pr <b>03.058</b> are not reset. Pr <b>03.058</b> is transferred to Pr <b>03.059</b> and Pr <b>03.032</b> is set to 1.																										
1	x	x	x	Undefined state region range is reduced from -30 mV to 30 mV. The marker pulse is only recognized if the pulse is 10 μs wide.																										
<i>Error Detection Level</i> (03.040)	<table border="1"> <thead> <tr> <th colspan="4">Bit</th> <th rowspan="2">Description</th> </tr> <tr> <th>3</th> <th>2</th> <th>1</th> <th>0</th> </tr> </thead> <tbody> <tr> <td>x</td> <td>x</td> <td>x</td> <td>1</td> <td>Enable wire break detection</td> </tr> <tr> <td>1</td> <td>x</td> <td>x</td> <td>x</td> <td>Disable trips <i>Encoder 1 to Encoder 6</i></td> </tr> </tbody> </table>	Bit				Description	3	2	1	0	x	x	x	1	Enable wire break detection	1	x	x	x	Disable trips <i>Encoder 1 to Encoder 6</i>										
Bit				Description																										
3	2	1	0																											
x	x	x	1	Enable wire break detection																										
1	x	x	x	Disable trips <i>Encoder 1 to Encoder 6</i>																										

\* These settings should only be used in RFC-A mode. If used in RFC-S mode a phase offset test must be performed after every power up.

### Incremental encoder with Frequency and Direction (F and D) or Forward and Reverse (CW and CCW) signals with or without commutation signals.

<i>Device Type</i> (03.038)	<b>FD</b> (1) for frequency and direction signals without commutation signals* <b>FR</b> (3) for forward and reverse signals without commutation signals* <b>FD Servo</b> (4) for frequency and direction signals with commutation signals <b>FR Servo</b> (5) for forward and reverse signals with commutation signals																													
<i>Supply Voltage</i> (03.036)	<b>5 V</b> (0), <b>8 V</b> (1) or <b>15 V</b> (2) <b>NOTE</b> If output voltage from the encoder is > 5 V, then the termination resistors must be disabled. Set Pr <b>03.039</b> to 0																													
<i>Rotary Line Per Revolution</i> (03.034)	Set to the number of pulses per revolution of the encoder divided by 2.																													
<i>Termination Select</i> (03.039)	0 = F or CW, D or CCW, Z termination resistors disabled 1 = F or CW, D or CCW termination resistors enabled and Z termination resistors disabled 2 = For CW, D or CCW, Z termination resistors enabled																													
<i>Marker Mode</i> (03.031)	<table border="1"> <thead> <tr> <th colspan="4">Bit</th> <th rowspan="2">Description</th> </tr> <tr> <th>3</th> <th>2</th> <th>1</th> <th>0</th> </tr> </thead> <tbody> <tr> <td>x</td> <td>x</td> <td>x</td> <td>1</td> <td>No action is taken unless marker flag is zero before marker event occurs</td> </tr> <tr> <td>x</td> <td>x</td> <td>1</td> <td>x</td> <td>Pr <b>03.028</b> and Pr <b>03.058</b> are set to zero</td> </tr> <tr> <td>x</td> <td>1</td> <td>x</td> <td>x</td> <td>Pr <b>03.028</b>, Pr <b>03.029</b>, Pr <b>03.030</b> and the related part of Pr <b>03.058</b> are not reset. Pr <b>03.058</b> is transferred to Pr <b>03.059</b> and Pr <b>03.032</b> is set to 1.</td> </tr> <tr> <td>1</td> <td>x</td> <td>x</td> <td>x</td> <td>Undefined state region range is reduced from -30 mV to 30 mV. The marker pulse is only recognized if the pulse is 10 μs wide.</td> </tr> </tbody> </table>	Bit				Description	3	2	1	0	x	x	x	1	No action is taken unless marker flag is zero before marker event occurs	x	x	1	x	Pr <b>03.028</b> and Pr <b>03.058</b> are set to zero	x	1	x	x	Pr <b>03.028</b> , Pr <b>03.029</b> , Pr <b>03.030</b> and the related part of Pr <b>03.058</b> are not reset. Pr <b>03.058</b> is transferred to Pr <b>03.059</b> and Pr <b>03.032</b> is set to 1.	1	x	x	x	Undefined state region range is reduced from -30 mV to 30 mV. The marker pulse is only recognized if the pulse is 10 μs wide.
Bit				Description																										
3	2	1	0																											
x	x	x	1	No action is taken unless marker flag is zero before marker event occurs																										
x	x	1	x	Pr <b>03.028</b> and Pr <b>03.058</b> are set to zero																										
x	1	x	x	Pr <b>03.028</b> , Pr <b>03.029</b> , Pr <b>03.030</b> and the related part of Pr <b>03.058</b> are not reset. Pr <b>03.058</b> is transferred to Pr <b>03.059</b> and Pr <b>03.032</b> is set to 1.																										
1	x	x	x	Undefined state region range is reduced from -30 mV to 30 mV. The marker pulse is only recognized if the pulse is 10 μs wide.																										
<i>Error Detection Level</i> (03.040)	<table border="1"> <thead> <tr> <th colspan="4">Bit</th> <th rowspan="2">Description</th> </tr> <tr> <th>3</th> <th>2</th> <th>1</th> <th>0</th> </tr> </thead> <tbody> <tr> <td>x</td> <td>x</td> <td>x</td> <td>1</td> <td>Enable wire break detection</td> </tr> <tr> <td>1</td> <td>x</td> <td>x</td> <td>x</td> <td>Disable trips <i>Encoder 1 to Encoder 7</i></td> </tr> </tbody> </table>	Bit				Description	3	2	1	0	x	x	x	1	Enable wire break detection	1	x	x	x	Disable trips <i>Encoder 1 to Encoder 7</i>										
Bit				Description																										
3	2	1	0																											
x	x	x	1	Enable wire break detection																										
1	x	x	x	Disable trips <i>Encoder 1 to Encoder 7</i>																										

\* These settings should only be used in RFC-A mode. If used in RFC-S mode a phase offset test must be performed after every power up.

### Absolute Sincos encoder with Hiperface, EnDat or BiSS serial communication, or Absolute EnDat or BiSS communication only encoder

<i>Device Type</i> (03.038)	<b>SC Hiperface</b> (7) for a Sincos encoder with Hiperface serial communications <b>EnDat</b> (8) for an EnDat communications only encoder <b>SC EnDat</b> (9) for a Sincos encoder with EnDat serial communications <b>BiSS</b> (13) for an BiSS communications only encoder <b>SC BiSS</b> (17) for a Sincos encoder with BiSS serial communications																								
<i>Supply Voltage</i> (03.036)	<b>5 V</b> (0), <b>8 V</b> (1) or <b>15 V</b> (2)																								
<i>Auto-configuration Select</i> (03.041)	Auto-configuration is enabled at default and automatically sets up the following parameters. <i>Rotary Turns Bits</i> (03.033) <i>Rotary Lines Per Revolutions</i> (03.034) <i>Comms Bits</i> (03.035) These parameters can be entered manually when Pr <b>03.041</b> is set to Disabled (0).																								
<i>Comms Baud Rate</i> (03.037)	100 k, 200 k, 300 k, 400 k, 500 k, 1 M, 1.5 M, 2 M, 4 M																								
<i>Error Detection Level</i> (03.040)	<table border="1"> <thead> <tr> <th colspan="4">Bit</th> <th rowspan="2">Description</th> </tr> <tr> <th>3</th> <th>2</th> <th>1</th> <th>0</th> </tr> </thead> <tbody> <tr> <td>x</td> <td>x</td> <td>x</td> <td>1</td> <td>Enable wire break detection</td> </tr> <tr> <td>x</td> <td>x</td> <td>1</td> <td>x</td> <td>Enable phase error detection</td> </tr> <tr> <td>1</td> <td>x</td> <td>x</td> <td>x</td> <td>Disable trips <i>Encoder 1 to Encoder 6</i></td> </tr> </tbody> </table> <p>So for example, to enable the wire break and phase error detection, set Pr <b>03.040</b> to 0011.</p>	Bit				Description	3	2	1	0	x	x	x	1	Enable wire break detection	x	x	1	x	Enable phase error detection	1	x	x	x	Disable trips <i>Encoder 1 to Encoder 6</i>
Bit				Description																					
3	2	1	0																						
x	x	x	1	Enable wire break detection																					
x	x	1	x	Enable phase error detection																					
1	x	x	x	Disable trips <i>Encoder 1 to Encoder 6</i>																					

### Absolute SSI communications only encoder, or Absolute Sincos encoder with SSI communications

<i>Device Type</i> (03.038)	<b>SSI (10)</b> for a SSI communications only encoder <b>SC SSI (11)</b> for a Sincos encoder with SSI serial communications																													
<i>Supply Voltage</i> (03.036)	<b>5 V (0), 8 V (1) or 15 V (2)</b>																													
<i>Rotary Line Per Revolution</i> (03.034)	Set the number of sine waves per revolution of the encoder																													
<i>SSI Binary Mode</i> (03.048)	Off = Gray Code On = Binary Mode																													
<i>Rotary Turns Bits</i> (03.033)	Set to the number of turns bits for the encoder (this is normally 12 bits for a SSI encoder)																													
<i>Comms Bits</i> (03.035)	Total number of bits of position information (this is usually 25 bits for a SSI encoder)																													
<i>Comms Baud Rate</i> (03.037)	100 k, 200 k, 300 k, 400 k, 500 k, 1 M, 1.5 M, 2 M, 4 M																													
<i>Error Detection Level</i> (03.040)	<table border="1"> <thead> <tr> <th colspan="4">Bit</th> <th rowspan="2">Description</th> </tr> <tr> <th>3</th> <th>2</th> <th>1</th> <th>0</th> </tr> </thead> <tbody> <tr> <td>x</td> <td>x</td> <td>x</td> <td>1</td> <td>Enable wire break detection</td> </tr> <tr> <td>x</td> <td>x</td> <td>1</td> <td>x</td> <td>Enable phase error detection</td> </tr> <tr> <td>x</td> <td>1</td> <td>x</td> <td>x</td> <td>Enable SSI power supply alarm bit monitor</td> </tr> <tr> <td>1</td> <td>x</td> <td>x</td> <td>x</td> <td>Disable trips <i>Encoder 1</i> to <i>Encoder 6</i></td> </tr> </tbody> </table> <p>So for example, to enable the wire break and phase error detection, set Pr <b>03.040</b> to 0011.</p>	Bit				Description	3	2	1	0	x	x	x	1	Enable wire break detection	x	x	1	x	Enable phase error detection	x	1	x	x	Enable SSI power supply alarm bit monitor	1	x	x	x	Disable trips <i>Encoder 1</i> to <i>Encoder 6</i>
Bit				Description																										
3	2	1	0																											
x	x	x	1	Enable wire break detection																										
x	x	1	x	Enable phase error detection																										
x	1	x	x	Enable SSI power supply alarm bit monitor																										
1	x	x	x	Disable trips <i>Encoder 1</i> to <i>Encoder 6</i>																										

### UVW commutation signal only encoders\*

<i>Device Type</i> (03.038)	Commutation Only (16) for a quadrature encoder with commutation signals*
<i>Supply Voltage</i> (03.036)	<b>5 V (0), 8 V (1) or 15 V (2)</b>
<i>Error Detection Level</i> (03.040)	Set to zero to disable wire break detection

\* This feedback device provides very low resolution feedback and should not be used for applications requiring a high level of performance. Due to the low resolution of UVW communication only encoders, it is recommended that the *P1 Feedback Filter* (03.042) is set to its maximum value. A value of 1 ms to 2 ms may also be required in the *Current Reference Filter* (00.017) and it is also recommended that the speed loop gains are set to a low value to obtain stable operation.

### Resolver

<i>Device Type</i> (03.038)	Resolver (14)																			
<i>Resolver Poles</i> (03.065)	Set number of Resolver poles 2 poles (1) to 20 poles (10)																			
<i>Resolver Excitation</i> (03.066)	Set Resolver excitation voltage and frequency 6 kHz 3V (0), 8 kHz 3V (1), 6 kHz 2V (2), 8 kHz 2V (3)																			
<i>Error Detection Level</i> (03.040)	<table border="1"> <thead> <tr> <th colspan="4">Bit</th> <th rowspan="2">Description</th> </tr> <tr> <th>3</th> <th>2</th> <th>1</th> <th>0</th> </tr> </thead> <tbody> <tr> <td>x</td> <td>x</td> <td>x</td> <td>1</td> <td>Enable wire break detection</td> </tr> <tr> <td>1</td> <td>x</td> <td>x</td> <td>x</td> <td>Disable trips <i>Encoder 1</i> to <i>Encoder 6</i></td> </tr> </tbody> </table> <p>So for example, to enable the wire break error detection, set Pr <b>03.040</b> to 0001.</p>	Bit				Description	3	2	1	0	x	x	x	1	Enable wire break detection	1	x	x	x	Disable trips <i>Encoder 1</i> to <i>Encoder 6</i>
Bit				Description																
3	2	1	0																	
x	x	x	1	Enable wire break detection																
1	x	x	x	Disable trips <i>Encoder 1</i> to <i>Encoder 6</i>																

### 7.5.3 P2 position interface

This section shows the parameter settings which must be made to use each of the compatible feedback device types with the P2 position interface on the drive. For more information on the parameters listed here please refer to the *Parameter Reference Guide*. If the position feedback device connected to the P2 position interface is required to be used for motor control feedback then Pr **03.026** will need to be set to P2 Drive (1).

**Table 7-4 Parameters required for feedback device set-up on the P2 position interface**

Parameter	AB, FD, FR	EnDat	SSI	BiSS
P2 Marker Mode (03.131)	✓			
P2 Rotary Turns Bits (03.133)		•	•	•
P2 Rotary Lines Per Revolution (03.134)	✓	•	•	•
P2 Comms Bits (03.135)		•	•	•
P2 Comms Baud Rate (03.137)		✓	✓	✓
P2 Device Type (03.138)	✓	✓	✓	✓
P2 Auto-configuration Select (03.141)		✓		✓

✓ Information required to be entered by the user.

- Parameter can be set-up automatically by the drive through auto-configuration. Parameter must be set by the user if auto-configuration is disabled (i.e. Pr **03.141** = Disabled (0)).

The P2 position interface does not have its own independent power supply output. Therefore, any position feedback device connected to the P2 position interface must either share the P1 power supply output on pin 13 of the 15-way D-type, or be supplied from an external source.

#### NOTE

The termination resistors are always enabled on the P2 position interface. Wire break detection is not available when using AB, FD or FR position feedback device types on the P2 position interface.

Table 7-4 shows a summary of the parameters required to set-up each feedback device. More detailed information follows.

Standard quadrature encoder (A, B, Z)																														
Device Type (03.138)	AB (1) for a quadrature encoder																													
Rotary Line Per Revolution (03.134)	Set to the number of lines per revolution of the encoder																													
Marker Mode (03.131)	<table border="1"> <thead> <tr> <th colspan="4">Bit</th> <th rowspan="2">Description</th> </tr> <tr> <th>3</th> <th>2</th> <th>1</th> <th>0</th> </tr> </thead> <tbody> <tr> <td>x</td> <td>x</td> <td>x</td> <td>1</td> <td>No action is taken unless marker flag is zero before marker event occurs</td> </tr> <tr> <td>x</td> <td>x</td> <td>1</td> <td>x</td> <td>Pr <b>03.128</b> and Pr <b>03.158</b> are set to zero</td> </tr> <tr> <td>x</td> <td>1</td> <td>x</td> <td>x</td> <td>Pr <b>03.128</b>, Pr <b>03.129</b>, Pr <b>03.130</b> and the related part of Pr <b>03.158</b> are not reset. Pr <b>03.158</b> is transferred to Pr <b>03.159</b> and Pr <b>03.132</b> is set to 1.</td> </tr> <tr> <td>1</td> <td>x</td> <td>x</td> <td>x</td> <td>This Bit in has no effect.</td> </tr> </tbody> </table>	Bit				Description	3	2	1	0	x	x	x	1	No action is taken unless marker flag is zero before marker event occurs	x	x	1	x	Pr <b>03.128</b> and Pr <b>03.158</b> are set to zero	x	1	x	x	Pr <b>03.128</b> , Pr <b>03.129</b> , Pr <b>03.130</b> and the related part of Pr <b>03.158</b> are not reset. Pr <b>03.158</b> is transferred to Pr <b>03.159</b> and Pr <b>03.132</b> is set to 1.	1	x	x	x	This Bit in has no effect.
	Bit				Description																									
	3	2	1	0																										
	x	x	x	1	No action is taken unless marker flag is zero before marker event occurs																									
	x	x	1	x	Pr <b>03.128</b> and Pr <b>03.158</b> are set to zero																									
x	1	x	x	Pr <b>03.128</b> , Pr <b>03.129</b> , Pr <b>03.130</b> and the related part of Pr <b>03.158</b> are not reset. Pr <b>03.158</b> is transferred to Pr <b>03.159</b> and Pr <b>03.132</b> is set to 1.																										
1	x	x	x	This Bit in has no effect.																										

Incremental encoder with Frequency and Direction (F and D), or Forward and Reverse (CW and CCW) signals																														
Device Type (03.138)	FD (2) for frequency and direction signals without commutation signals FR (3) for forward and reverse signals without commutation signals																													
Rotary Line Per Revolution (03.134)	Set to the number of pulses per revolution of the encoder divided by 2																													
Marker Mode (03.131)	<table border="1"> <thead> <tr> <th colspan="4">Bit</th> <th rowspan="2">Description</th> </tr> <tr> <th>3</th> <th>2</th> <th>1</th> <th>0</th> </tr> </thead> <tbody> <tr> <td>x</td> <td>x</td> <td>x</td> <td>1</td> <td>No action is taken unless marker flag is zero before marker event occurs</td> </tr> <tr> <td>x</td> <td>x</td> <td>1</td> <td>x</td> <td>Pr <b>03.128</b> and Pr <b>03.158</b> are set to zero</td> </tr> <tr> <td>x</td> <td>1</td> <td>x</td> <td>x</td> <td>Pr <b>03.128</b>, Pr <b>03.129</b>, Pr <b>03.130</b> and the related part of Pr <b>03.158</b> are not reset. Pr <b>03.158</b> is transferred to Pr <b>03.159</b> and Pr <b>03.132</b> is set to 1.</td> </tr> <tr> <td>1</td> <td>x</td> <td>x</td> <td>x</td> <td>This Bit in has no effect.</td> </tr> </tbody> </table>	Bit				Description	3	2	1	0	x	x	x	1	No action is taken unless marker flag is zero before marker event occurs	x	x	1	x	Pr <b>03.128</b> and Pr <b>03.158</b> are set to zero	x	1	x	x	Pr <b>03.128</b> , Pr <b>03.129</b> , Pr <b>03.130</b> and the related part of Pr <b>03.158</b> are not reset. Pr <b>03.158</b> is transferred to Pr <b>03.159</b> and Pr <b>03.132</b> is set to 1.	1	x	x	x	This Bit in has no effect.
	Bit				Description																									
	3	2	1	0																										
	x	x	x	1	No action is taken unless marker flag is zero before marker event occurs																									
	x	x	1	x	Pr <b>03.128</b> and Pr <b>03.158</b> are set to zero																									
x	1	x	x	Pr <b>03.128</b> , Pr <b>03.129</b> , Pr <b>03.130</b> and the related part of Pr <b>03.158</b> are not reset. Pr <b>03.158</b> is transferred to Pr <b>03.159</b> and Pr <b>03.132</b> is set to 1.																										
1	x	x	x	This Bit in has no effect.																										

**Absolute EnDat communication only encoder**  
**Absolute BiSS communication only encoder**

<i>Device Type</i> (03.138)	<b>EnDat</b> (4) for an EnDat communications only encoder <b>BiSS</b> (6) for a BiSS communication only encoder														
<i>Auto-configuration Select</i> (03.141)	Auto-configuration is enabled at default and automatically sets up the following parameters: <i>Rotary Turns Bits</i> (03.133) <i>Comms Bits</i> (03.135) These parameters can be entered manually when Pr <b>03.141</b> is set to Disabled (0).														
<i>Comms Baud Rate</i> (03.137)	100 k, 200 k, 300 k, 400 k, 500 k, 1 M, 1.5 M, 2 M, 4 M														
<i>Error Detection Level</i> (03.140)	<table border="1"> <thead> <tr> <th colspan="4">Bit</th> <th rowspan="2">Description</th> </tr> <tr> <th>3</th> <th>2</th> <th>1</th> <th>0</th> </tr> </thead> <tbody> <tr> <td>1</td> <td>x</td> <td>x</td> <td>x</td> <td>Disable trips <i>Encoder 4 to Encoder 6</i></td> </tr> </tbody> </table>	Bit				Description	3	2	1	0	1	x	x	x	Disable trips <i>Encoder 4 to Encoder 6</i>
Bit				Description											
3	2	1	0												
1	x	x	x	Disable trips <i>Encoder 4 to Encoder 6</i>											

**Absolute SSI communications only encoder**

<i>Device Type</i> (03.138)	<b>SSI</b> (5) for a SSI communications only encoder																			
<i>SSI Binary Mode</i> (03.148)	<b>Off</b> (0) = Gray Code <b>On</b> (1) = Binary Mode																			
<i>Rotary Turns Bits</i> (03.133)	Set to the number of turns bits for the encoder (this is usually 12 bits for a multi-turn SSI encoder)																			
<i>Comms Bits</i> (03.135)	Total number of bits of position information for the encoder (this is usually 25 bits for a multi-turn SSI encoder)																			
<i>Comms Baud Rate</i> (03.137)	100 k, 200 k, 300 k, 400 k, 500 k, 1 M, 1.5 M, 2 M, 4 M																			
<i>Error Detection Level</i> (03.140)	<table border="1"> <thead> <tr> <th colspan="4">Bit</th> <th rowspan="2">Description</th> </tr> <tr> <th>3</th> <th>2</th> <th>1</th> <th>0</th> </tr> </thead> <tbody> <tr> <td>x</td> <td>1</td> <td>x</td> <td>x</td> <td><i>Enable SSI power supply alarm bit monitor</i></td> </tr> <tr> <td>1</td> <td>x</td> <td>x</td> <td>x</td> <td>Disable trips <i>Encoder 4 to Encoder 6</i></td> </tr> </tbody> </table>	Bit				Description	3	2	1	0	x	1	x	x	<i>Enable SSI power supply alarm bit monitor</i>	1	x	x	x	Disable trips <i>Encoder 4 to Encoder 6</i>
Bit				Description																
3	2	1	0																	
x	1	x	x	<i>Enable SSI power supply alarm bit monitor</i>																
1	x	x	x	Disable trips <i>Encoder 4 to Encoder 6</i>																

## 7.6 Encoder Simulation Output Set-up

The drive supports four modes of encoder simulation output.

- Hardware mode - Incremental signals (AB, FD, FR)
- Software mode - Incremental signals (AB, FD, FR)
- Software mode - Ratio
- Software mode - Absolute SSI data

The availability of the encoder simulation output on the 15-way D-type on the drive is dependent on the type of feedback device connected to the P1 position interface. See Table 4-7 on page 24 for more information on the availability of the encoder simulation output. The status of the encoder simulation output can be seen in *Encoder Simulation Status* (03.086) as follows:

- None (0) The encoder simulation output is not enabled or is not available
- Full (1) Full encoder simulation with marker output is available
- No Marker (2) Encoder simulation without marker output is available

This section shows the parameter settings which must be made to use the encoder simulation output on the drive. For more information on the parameters listed here please refer to the Parameter Reference Guide.

### 7.6.1 Hardware mode - Incremental signals (AB, FD, or FR)

Hardware mode provides incremental signals derived via hardware from the P1 position feedback interface on the drive, with negligible delay. The supported incremental output signals are AB, FD and FR. Hardware mode only produces an output when the input device connected to the P1 position interface is AB, FD, FR, SC, SC Hiperface, SC EnDat or SC SSI type devices. It should be noted that with a SINCOS source device the output is based on the zero crossings of the sine wave inputs and does not include interpolation.

Hardware mode set-up	
<i>Encoder Simulation Source</i> (03.085)	This parameter must be set to <b>03.029</b> to select the P1 position interface as the source.
<i>Encoder Simulation Mode</i> (03.088)	Set to a value of <b>Hardware (0)</b>
<i>Encoder Simulation Hardware Divider</i> (03.089)	This parameter defines the divider ratio between the device connected to the P1 position feedback interface and the output. <b>0</b> = 1/1 <b>1</b> = 1/2 <b>2</b> = 1/4 <b>3</b> = 1/8 <b>4</b> = 1/16 <b>5</b> = 1/32 <b>6</b> = 1/64 <b>7</b> = 1/128
<i>Encoder Simulation Hardware Marker Lock</i> (03.090)	<b>0</b> = The marker output is derived directly from the marker input <b>1</b> = The incremental output signals are adjusted on each marker event so that the A and B are high with an AB type output, or F is high with an FD or FR type output
<i>Encoder Simulation Output Mode</i> (03.098)	<b>AB/Gray (0)</b> for a AB quadrature output signals <b>FD/Binary (1)</b> for Frequency and Direction output signals <b>FR/Binary (2)</b> for Forward and Reverse output signals

### 7.6.2 Software mode - Incremental signals (AB, FD, or FR)

In software mode the encoder simulation output is derived via software from the selected source with a minimum delay of 250 µs which may be extended with *Encoder Simulation Sample Period* (03.087). For incremental output signals, the resolution of the output can be defined by either selecting the required output lines per revolution or by an output ratio.

#### Lines per revolution

The output resolution of the encoder simulation output is defined by *Encoder Simulation Output Lines Per Revolution* (03.092).

AB quadrature output signals, software mode setup – Lines per revolution	
<i>Encoder Simulation Source</i> (03.085)	Set to the parameter number of the position source Pr <b>03.029</b> to use the P1 position interface on the drive as the source. Pr <b>03.129</b> to use the P2 position interface on the drive as the source. This parameter can be set to any other valid position reference generated by the drive or an option module.
<i>Encoder Simulation Mode</i> (03.088)	Set to a value of <b>Lines Per Rev (1)</b>
<i>Encoder Simulation Output Lines Per Revolution</i> (03.092)	Set to the required output lines per revolution. The maximum output lines per revolution are 16384.
<i>Encoder Simulation Output Mode</i> (03.098)	<b>AB/Gray (0)</b> for a AB quadrature output signals

Frequency and Direction or Forward and Reverse output signals, software mode setup – Lines per revolution	
<i>Encoder Simulation Source</i> (03.085)	Set to the parameter number of the position source Pr <b>03.029</b> to use the P1 position interface on the drive as the source. Pr <b>03.129</b> to use the P2 position interface on the drive as the source. This parameter can be set to any other valid position reference generated by the drive or an option module.
<i>Encoder Simulation Mode</i> (03.088)	Set to a value of <b>Lines Per Rev (1)</b>
<i>Encoder Simulation Output Lines Per Revolution</i> (03.092)	Set to the required output pulse per revolution divided by 2. For example if 2000 pulses per revolution is required, set this parameter to 1000.
<i>Encoder Simulation Output Mode</i> (03.098)	<b>FD/Binary (1)</b> for Frequency and Direction output signals <b>FR/Binary (2)</b> for Forward and Reverse output signals

## Ratio

In ratio mode the resolution of the input source is based on a 16 bit position feedback device (i.e. equivalent to an AB quadrature encoder with a resolution of 16384 lines per revolution). The output resolution of the encoder simulation output is defined by the ratio of *Encoder Simulation Numerator* (03.093) and *Encoder Simulation Denominator* (03.094).

### AB quadrature output signals, software mode setup – Ratio Frequency and Direction or Forward and Reverse output signals, software mode setup

<i>Encoder Simulation Source</i> (03.085)	Set to the parameter number of the position source Pr <b>03.029</b> to use the P1 position interface on the drive as the source. Pr <b>03.129</b> to use the P2 position interface on the drive as the source. This parameter can be set to any other valid position reference generated by the drive or an option module.
<i>Encoder Simulation Mode</i> (03.088)	Set to a value of <b>Ratio (2)</b>
<i>Encoder Simulation Numerator</i> (03.093) and <i>Encoder Simulation Denominator</i> (03.094)	Set these two parameters to give the required output ratio.
<i>Encoder Simulation Output Mode</i> (03.098)	<b>AB/Gray</b> (0) for a AB quadrature output signals <b>FD/Binary</b> (1) for Frequency and Direction output signals <b>FR/Binary</b> (2) for Forward and Reverse output signals

## Software mode - Absolute SSI data

In software mode the encoder simulation output is derived via software from the selected source with a minimum delay of 250 µs which may be extended with *Encoder Simulation Sample Period* (03.087). In SSI output mode drive will simulate an SSI encoder, where the number of bits and the format of the position message can be adjusted.

### Absolute SSI data, software mode setup

<i>Encoder Simulation Source</i> (03.085)	Set to the parameter number of the position source Pr <b>03.029</b> to use the P1 position interface on the drive as the source. Pr <b>03.129</b> to use the P2 position interface on the drive as the source. This parameter can be set to any other valid position reference generated by the drive or an option module.
<i>Encoder Simulation Mode</i> (03.088)	Set to a value of <b>SSI (3)</b>
<i>Encoder Simulation SSI Turns Bits</i> (03.096)	Set to the number of bits representing the number of turns in the position message.
<i>Encoder Simulation SSI Comms Bits</i> (03.097)	Set to the number bits in the whole position message.
<i>Encoder Simulation Output Mode</i> (03.098)	<b>AB/Gray</b> (0) for position data in Gray code format <b>FD/Binary</b> (1) or <b>FR/Binary</b> (2) for position data in binary format


## 8 Optimization

This chapter takes the user through methods of optimizing the drive set-up and maximize the performance. The auto-tuning features of the drive simplify the optimization tasks.

### 8.1 Motor map parameters

#### 8.1.1 RFC-S mode

##### Permanent magnet motor with Position feedback

<b>Pr 00.046 {05.007} Rated Current</b>	<b>Defines the maximum motor continuous current</b>
The motor rated current parameter must be set to the maximum continuous current of the motor. The motor rated current is used in the following: <ul style="list-style-type: none"> <li>• Current limits (see section 8.2 <i>Current limits</i> on page 91, for more information)</li> <li>• Motor thermal overload protection (see section 8.3 <i>Motor thermal protection</i> on page 91, for more information)</li> </ul>	
<b>Pr 00.042 {05.011} Number Of Motor Poles</b>	<b>Defines the number of motor poles</b>
The number of motor poles parameter defines the number of electrical revolutions in one whole mechanical revolution of the motor. This parameter must be set correctly for the control algorithms to operate correctly. When Pr <b>00.042</b> is set to "Automatic" the number of poles is 6.	
<b>Pr 00.040 {05.012} Autotune</b>	
There are four autotune tests available in RFC-S mode, a stationary autotune, a rotating autotune, mechanical load measurement tests to measure load dependent parameters. <ul style="list-style-type: none"> <li>• <b>Stationary Autotune</b> The stationary autotune can be used when the motor is loaded and it is not possible uncouple the load from motor shaft. This test can be used to measure all the necessary parameters for basic control. During the stationary autotune, a test is performed to locate the flux axis of the motor. However this test may not be able to calculate such an accurate value for the <i>Position Feedback Phase Angle</i> (00.043) as compared to rotating autotune. A stationary test is performed to measure <i>Stator Resistance</i> (05.017), <i>Ld</i> (05.024), <i>Maximum Deadtime Compensation</i> (05.059), <i>Current At Maximum Deadtime Compensation</i> (05.060), <i>No Load Lq</i> (05.072). If <i>Enable Stator Compensation</i> (05.049) = 1 then <i>Stator Base Temperature</i> (05.048) is made equal to <i>Stator Temperature</i> (05.046). The <i>Stator Resistance</i> (05.017) and the <i>Ld</i> (05.024) are then used to set up <i>Current controller Kp Gain</i> (00.038) and <i>Current Controller Ki Gain</i> (00.039). If sensorless mode is not selected then <i>Position Feedback Phase Angle</i> (00.043) is set up for the position from the position feedback interface selected with <i>Motor Control Feedback Select</i> (03.026). To perform a Stationary autotune, set Pr <b>00.040</b> to 1, and provide the drive with both an enable signal (terminal 2 and 6) and a run signal (terminal 11 or 13).</li> <li>• <b>Rotating Autotune</b> The rotating autotune must be performed on unloaded motor. This test can be used to measure all the necessary parameters for the basic control and parameters for cancelling the effects of the cogging torque. During the rotating autotune, <i>Rated Current</i> (00.046) is applied and the motor is rotated by 2 electrical revolutions (i.e. up to 2 mechanical revolutions) in the required direction. If sensorless mode is not selected then the <i>Position Feedback Phase Angle</i> (00.043) is set-up for the position from the position feedback interface selected with <i>Motor Control Feedback Select</i> (03.026). A stationary test is then performed to measure <i>Stator Resistance</i> (05.017), <i>Ld</i> (05.024), <i>Maximum Deadtime Compensation</i> (05.059), <i>Current At Maximum Deadtime Compensation</i> (05.060) and <i>No Load Lq</i> (05.072). <i>Stator Resistance</i> (05.017) and <i>Ld</i> (05.024) are used to set up <i>Current Controller Kp Gain</i> (00.038) and <i>Current Controller Ki Gain</i> (00.039). This is only done once during the test, and so the user can make further adjustments to the current controller gains if required. To perform a Rotating autotune, set Pr <b>00.040</b> to 2, and provide the drive with both an enable signal (terminal 2 &amp; 6) and a run signal (terminal 11 or 13).</li> </ul>	
	
<ul style="list-style-type: none"> <li>• <b>Mechanical load measurement test using signal injection</b> The mechanical load measurement test using signal injection, measures the mechanical characteristic of the motor and load by rotating the motor at the speed defined by the present speed reference and injecting a series of speed test signals. This test should only be used provided all the basic control parameters (including <i>Torque Per Amp</i> (05.032)) have been set-up correctly and the speed controller parameters should be set to conservative levels, such as the default values, so that the motor is stable when it runs. The test measures the motor and load inertia, which can be used in automatic set-up of the speed controller gains and in producing a torque feed-forward term. If <i>Mechanical Load Test Level</i> (05.021) is left at its default value of zero then the peak level of the injection signal will be 1 % of the maximum speed reference subject to a maximum of 500 rpm. If a different test level is required then <i>Mechanical Load Test Level</i> (05.021) should be set to a non-zero value to define the level as a percentage of the maximum speed reference, again subject to a maximum of 500 rpm. The user defined speed reference which defines the speed of the motor should be set to a level higher than the test level, but not high enough for flux weakening to become active. In some cases, however it is possible to perform the test at zero speed provided the motor is free to move, but it may be necessary to increase the test signal from the default value. The test will give the correct results when there is a static load applied to the motor and in the presence of mechanical damping. This test should be used if possible, however for sensorless mode, or if the speed controller cannot be set up for stable operation an alternative test is provided (<i>Autotune</i> (00.040) = 4) where a series of torque levels are applied to accelerate and decelerate the motor to measure the inertia. <ol style="list-style-type: none"> <li>1. A rotating test is performed in which the motor is accelerated with the currently selected ramps up to the currently selected speed reference, and this speed is maintained for the duration of the test. <i>Motor And Load Inertia</i> (03.018) and <i>Inertia Times 1000</i> (04.033) are set up.</li> </ol> To perform this autotune test, set Pr <b>00.040</b> to 3 and provide the drive with both an enable signal (terminal 2 and 6) and a run signal (terminal 11 or 13). </li> <li>• <b>Mechanical load measurement using applied torque</b> Auto-tune test 3 should normally be used for mechanical load measurement, but under some circumstances this test may be used as an alternative. This test is likely to give incorrect results if standard ramp mode is active. A series of progressively larger torque levels are applied to the motor (20 %, 40 % ... 100 % of rated torque) to accelerate the motor up to 3/4 x <i>Rated Speed</i> (00.045) to determine the inertia from the acceleration/deceleration time. The test attempts to reach the required speed within 5s, but if this fails the next torque level is used. When 100 % torque is used the test allows 60 s for the required speed to be reached, but if this is unsuccessful, a trip is initiated. To reduce the time taken for the test it is possible to define the level of torque to be used for the test by setting <i>Mechanical Load Test Level</i> (05.021) to a non-zero value. When the test level is defined the test is only carried out at the defined test level and 60 s is allowed for the motor to reach the required speed. It should be noted that if the maximum speed allows for flux weakening then it may not be possible to achieve the required torque level to accelerate the motor fast enough. If this is the case, the maximum speed reference should be reduced. <ol style="list-style-type: none"> <li>1. The motor is accelerated in the required direction up to 3/4 of the maximum speed reference and then decelerated to zero speed.</li> <li>2. The test is repeated with progressively higher torques until the required speed is reached.</li> <li>3. <i>Motor And Load Inertia</i> (03.018) and <i>Inertia Times 1000</i> (04.033) are set up. To perform this autotune test, set Pr 00.040 to 4 and provide the drive with both an enable signal (terminal 2 and 6) and a run signal (terminal 11 or 13).</li> </ol> </li> </ul>	

### Pr 00.038 {04.013} / Pr 00.039 {04.014} Current Loop Gains

The current loop gains proportional (Kp) and integral (Ki) gains control the response of the current loop to a change in current (torque) demand. The default values give satisfactory operation with most motors. However, for optimal performance in dynamic applications it may be necessary to change the gains to improve the performance. The proportional gain (Pr 00.038) is the most critical value in controlling the performance. The values for the current loop gains can be calculated by performing a stationary or rotating autotune (see *Autotune* Pr 00.040, earlier in this table) the drive measures the *Stator Resistance* (05.017) and *Transient Inductance* (05.024) of the motor and calculates the current loop gains.

This will give a step response with minimum overshoot after a step change of current reference. The proportional gain can be increased by a factor of 1.5 giving a similar increase in bandwidth; however, this gives a step response with approximately 12.5 % overshoot. The equation for the integral gain gives a conservative value. In some applications where it is necessary for the reference frame used by the drive to dynamically follow the flux very closely (i.e. high speed Sensorless RFC-A induction motor applications) the integral gain may need to have a significantly higher value.

### Speed loop gains (Pr 00.007 {03.010}, Pr 00.008 {03.011}, Pr 00.009 {03.012})

The speed loop gains control the response of the speed controller to a change in speed demand. The speed controller includes proportional (Kp) and integral (Ki) feed forward terms, and a differential (Kd) feedback term. The drive holds two sets of these gains and either set may be selected for use by the speed controller with Pr 03.016. If Pr 03.016 = 0, gains Kp1, Ki1 and Kd1 (Pr 00.007 to Pr 00.009) are used, and if Pr 03.016 = 1, gains Kp2, Ki2 and Kd2 (Pr 03.013 to Pr 03.015) are used. Pr 03.016 may be changed when the drive is enabled or disabled. If the load is predominantly a constant inertia and constant torque, the drive can calculate the required Kp and Ki gains to give a required compliance angle or bandwidth dependant on the setting of Pr 03.017.

#### *Speed Controller Proportional Gain (Kp), Pr 00.007 {03.010} and Pr 03.013*

If the proportional gain has a value and the integral gain is set to zero the controller will only have a proportional term, and there must be a speed error to produce a torque reference. Therefore as the motor load increases there will be a difference between the reference and actual speeds. This effect, called regulation, depends on the level of the proportional gain, the higher the gain the smaller the speed error for a given load. If the proportional gain is too high either the acoustic noise produced by speed feedback quantization becomes unacceptable, or the stability limit is reached.

#### *Speed Controller Integral Gain (Ki), Pr 00.008 {03.011} and Pr 03.014*

The integral gain is provided to prevent speed regulation. The error is accumulated over a period of time and used to produce the necessary torque demand without any speed error. Increasing the integral gain reduces the time taken for the speed to reach the correct level and increases the stiffness of the system, i.e. it reduces the positional displacement produced by applying a load torque to the motor. Unfortunately increasing the integral gain also reduces the system damping giving overshoot after a transient. For a given integral gain the damping can be improved by increasing the proportional gain. A compromise must be reached where the system response, stiffness and damping are all adequate for the application.

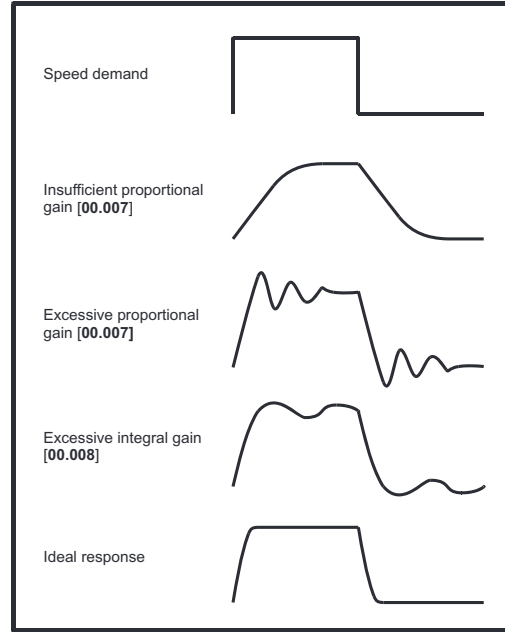
#### *Differential Gain (Kd), Pr 00.009 {03.012} and Pr 03.015*

The differential gain is provided in the feedback of the speed controller to give additional damping. The differential term is implemented in a way that does not introduce excessive noise normally associated with this type of function. Increasing the differential term reduces the overshoot produced by under-damping, however, for most applications the proportional and integral gains alone are sufficient.

### Speed loop gains (cont) (Pr 00.007 {03.010}, Pr 00.008 {03.011}, Pr 00.009 {03.012})

There are three methods of tuning the speed loop gains dependant on the setting of Pr 03.017:

- Pr 03.017 = 0, User set-up.  
This involves the connecting of an oscilloscope to analog output 1 to monitor the speed feedback.  
Give the drive a step change in speed reference and monitor the response of the drive on the oscilloscope.  
The proportional gain (Kp) should be set up initially. The value should be increased up to the point where the speed overshoots and then reduced slightly.  
The integral gain (Ki) should then be increased up to the point where the speed becomes unstable and then reduced slightly.  
It may now be possible to increase the proportional gain to a higher value and the process should be repeated until the system response matches the ideal response as shown.  
The diagram shows the effect of incorrect P and I gain settings as well as the ideal response.
- Pr 03.017 = 1, Bandwidth set-up  
If bandwidth based set-up is required, the drive can calculate Kp and Ki if the following parameters are set up correctly:  
Pr 03.020 - Required bandwidth,  
Pr 03.021 - Required damping factor,  
Pr 03.018 - Motor and load inertia.  
The drive can be made to measure the motor and load inertia by performing a mechanical load measurement autotune (see *Autotune* Pr 00.040, earlier in this table).
- Pr 03.017 = 2, Compliance angle set-up  
If compliance angle based set-up is required, the drive can calculate Kp and Ki if the following parameters are set up correctly:  
Pr 03.019 - Required compliance angle,  
Pr 03.021 - Required damping factor,  
Pr 03.018 - Motor and load inertia. The drive can be made to measure the motor and load inertia by performing a mechanical load autotune (see *Autotune* Pr 00.040, earlier in this table).
- Pr 03.017 = 3, Kp gains times 16  
If *Speed Controller Set-up Method* (03.017) = 3 the selected proportional gain used by the drive is multiplied by 16.



- Pr 03.017 = 4 - 6  
If *Speed Controller Set-up Method* (03.017) is set to a value from 4 to 6 the *Speed Controller Proportional Gain Kp1* (03.010) and *Speed Controller Integral Gain Ki1* (03.011) are automatically set up to give the bandwidths given in the table below and a damping factor of unity. These settings give low, standard or high performance.

Speed Controller Set-up Method (03.017)	Performance	Bandwidth
4	Low	5 Hz
5	Standard	25 Hz
6	High	100 Hz

- Pr 03.017 = 7  
If *Speed Controller Set-up Method* (03.017) = 7 then *Speed Controller Proportional Gain Kp1* (03.010), *Speed Controller Integral Gain Ki1* (03.011) and *Speed Controller Differential Feedback Gain Kd1* (03.012) are set up to give a closed-loop speed controller response that approximates to a first order system with a transfer function of  $1 / (s\tau + 1)$ , where  $\tau = 1/\omega_{bw}$  and  $\omega_{bw} = 2\pi \times \text{Bandwidth}$  (03.020). In this case the damping factor is meaningless, and *Damping Factor* (03.021) and *Compliance Angle* (03.019) have no effect.

## 8.1.2 RFC-S Sensorless mode

### Permanent magnet motor without Position feedback

<b>Pr 00.046 {05.007} Rated Current</b>	<b>Defines the maximum motor continuous current</b>
<p>The motor rated current parameter must be set to the maximum continuous current of the motor. The motor rated current is used in the following:</p> <ul style="list-style-type: none"> <li>• Current limits (see section 8.2 <i>Current limits</i> on page 91, for more information)</li> <li>• Motor thermal overload protection (see section 8.3 <i>Motor thermal protection</i> on page 91, for more information)</li> </ul>	
<b>Pr 00.042 {05.011} Number Of Motor Poles</b>	<b>Defines the number of motor poles</b>
<p>The number of motor poles parameter defines the number of electrical revolutions in one whole mechanical revolution of the motor. This parameter must be set correctly for the control algorithms to operate correctly. When Pr <b>00.042</b> is set to "Automatic" the number of poles is 6.</p>	
<b>Pr 00.040 {05.012} Autotune</b>	
<p>There are three autotune tests available in RFC-S sensorless mode, a stationary autotune and an inertia measurement test.</p> <ul style="list-style-type: none"> <li>• Stationary Autotune (Pr <b>00.040 {05.012}</b> = 1)</li> </ul> <p>The stationary autotune can be used to measure all the necessary parameters for basic control. The tests measures <i>Stator Resistance</i> (05.017), <i>Ld</i> (05.024), <i>No Load Lq</i> Pr <b>00.056 {05.072}</b>, <i>Maximum Deadtime Compensation</i> (05.059) and <i>Current At Maximum Deadtime Compensation</i> (05.060). If <i>Enable Stator Compensation</i> (05.049) = 1 then <i>Stator Base Temperature</i> (05.048) is made equal to <i>Stator Temperature</i> (05.046). The <i>Stator Resistance</i> (05.017) and <i>Ld</i> (05.024) are then used to set up <i>Current controller Kp Gain</i> Pr <b>00.038 {04.013}</b> and <i>Current Controller Ki Gain</i> Pr <b>00.039 {04.014}</b>. To perform a Stationary autotune, set Pr <b>00.040</b> to 1, and provide the drive with both an enable signal (terminal 2 &amp; 6) and a run signal (terminal 11 or 13).</p> <ul style="list-style-type: none"> <li>• Rotating Autotune (Pr <b>00.040 {05.012}</b> = 2)</li> </ul> <p>In sensorless mode, if Rotating autotune is selected (Pr <b>00.040</b> = 2), then a stationary autotune is performed.</p> <ul style="list-style-type: none"> <li>• Inertia measurement test (Pr <b>00.040 {05.012}</b> = 4)</li> </ul> <p><b>NOTE:</b> It is not possible to perform this test if, after autotune, the ratio <i>No load Lq</i> Pr <b>00.056 {05.072}</b> / <i>Ld</i> (05.024) &lt; 1.1 and Pr <b>00.054 {05.064}</b> has been set to Non-salient.</p> <p>The inertia measurement test can measure the total inertia of the load and the motor. This is used to set the speed loop gains (see <i>Speed loop gains</i>) and to provide torque feed-forwards when required during acceleration. The test may give inaccurate results, if the motor rated speed is not set to the correct value for the motor, or if standard ramp mode is active. During the inertia measurement test a series of progressively larger torque levels are applied to the motor (20 %, 40 % ... 100 % of rated torque) to accelerate the motor up to 3/4 x <i>Rated Speed</i> Pr <b>00.045 {05.008}</b> to determine the inertia from the acceleration/ deceleration time. The test attempts to reach the required speed within 5 s, but if this fails the next torque level is used. When 100 % torque is used the test allows 60 s for the required speed to be reached, but if this is unsuccessful an Autotune trip is initiated. To reduce the time taken for the test it is possible to define the level of torque to be used for the test by setting <i>Mechanical Load Test Level</i> (05.021) to a non-zero value. When the test level is defined the test is only carried out at the defined test level and 60 s is allowed for the motor to reach the required speed. It should be noted that if the maximum speed allows for flux weakening then it may not be possible to achieve the required torque level to accelerate the motor quickly enough. If this is the case, the maximum speed reference should be reduced. To perform an Inertia measurement autotune, set Pr <b>00.040</b> to 4, and provide the drive with both an enable signal (on terminal 2 &amp; 6) and a run signal (on terminal 11 or 13).</p> <p>Following the completion of an autotune test the drive will go into the inhibit state. The drive must be placed into a controlled disable condition before the drive can be made to run at the required reference. The drive can be put in to a controlled disable condition by removing the Safe Torque Off signal from terminal 2 &amp; 6, setting the drive Enable Parameter (<b>06.015</b>) to Off (0) or disabling the drive via the control word (Pr <b>06.042</b> &amp; Pr <b>06.043</b>).</p>	
<b>Pr 00.038 {04.013} / Pr 00.039 {04.014} Current Loop Gains</b>	
<p>The current loop gains proportional (Kp) and integral (Ki) gains control the response of the current loop to a change in current (torque) demand. The default values give satisfactory operation with most motors. However, for optimal performance in dynamic applications it may be necessary to change the gains to improve the performance. The proportional gain Pr <b>00.038 {04.013}</b> is the most critical value in controlling the performance. The values for the current loop gains can be calculated by performing a stationary or rotating autotune (see <i>Autotune</i> Pr <b>00.040</b>, earlier in this table) the drive measures the <i>Stator Resistance</i> (05.017) and <i>Transient Inductance</i> (05.024) of the motor and calculates the current loop gains.</p> <p>This will give a step response with minimum overshoot after a step change of current reference. The proportional gain can be increased by a factor of 1.5 giving a similar increase in bandwidth; however, this gives a step response with approximately 12.5 % overshoot. The equation for the integral gain gives a conservative value. In some applications where it is necessary for the reference frame used by the drive to dynamically follow the flux very closely the integral gain may need to have a significantly higher value.</p>	

### Speed Loop Gains (Pr 00.007 {03.010}, Pr 00.008 {03.011}, Pr 00.009 {03.012})

The speed loop gains control the response of the speed controller to a change in speed demand. The speed controller includes proportional (Kp) and integral (Ki) feed forward terms, and a differential (Kd) feedback term. The drive holds two sets of these gains and either set may be selected for use by the speed controller with Pr 03.016. If Pr 03.016 = 0, gains Kp1, Ki1 and Kd1 (Pr 00.007 to Pr 00.009) are used, and if Pr 03.016 = 1, gains Kp2, Ki2 and Kd2 (Pr 03.013 to Pr 03.015) are used. Pr 03.016 may be changed when the drive is enabled or disabled. If the load is predominantly a constant inertia and constant torque, the drive can calculate the required Kp and Ki gains to give a required compliance angle or bandwidth dependant on the setting of Pr 03.017.

**NOTE: In sensorless mode, the speed controller bandwidth may need to be limited to 10 Hz or less for stable operation.**

#### Speed Controller Proportional Gain (Kp), Pr 00.007 {03.010} and Pr 03.013

If the proportional gain has a value and the integral gain is set to zero the controller will only have a proportional term, and there must be a speed error to produce a torque reference. Therefore as the motor load increases there will be a difference between the reference and actual speeds. This effect, called regulation, depends on the level of the proportional gain, the higher the gain the smaller the speed error for a given load. If the proportional gain is too high either the acoustic noise produced by speed feedback quantization becomes unacceptable, or the stability limit is reached.

#### Speed Controller Integral Gain (Ki), Pr 00.008 {03.011} and Pr 03.014

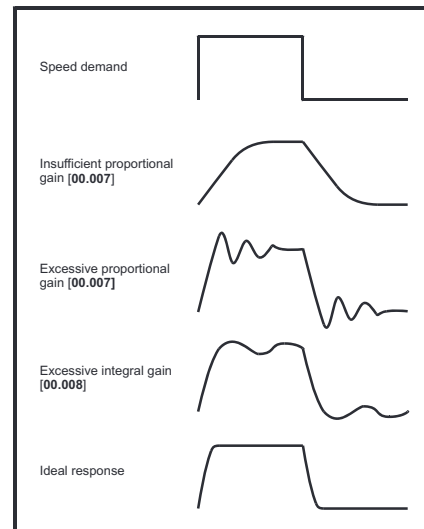
The integral gain is provided to prevent speed regulation. The error is accumulated over a period of time and used to produce the necessary torque demand without any speed error. Increasing the integral gain reduces the time taken for the speed to reach the correct level and increases the stiffness of the system, i.e. it reduces the positional displacement produced by applying a load torque to the motor. Unfortunately increasing the integral gain also reduces the system damping giving overshoot after a transient. For a given integral gain the damping can be improved by increasing the proportional gain. A compromise must be reached where the system response, stiffness and damping are all adequate for the application. For RFC-S Sensorless mode, it is unlikely that the integral gain can be increased much above 0.50.

#### Differential Gain (Kd), Pr 00.009 {03.012} and Pr 03.015

The differential gain is provided in the feedback of the speed controller to give additional damping. The differential term is implemented in a way that does not introduce excessive noise normally associated with this type of function. Increasing the differential term reduces the overshoot produced by under-damping, however, for most applications the proportional and integral gains alone are sufficient.

There are six methods of tuning the speed loop gains dependant on the setting of Pr 03.017:

1. Pr 03.017 = 0, User set-up.  
This involves the connecting of an oscilloscope to analog output 1 to monitor the speed feedback.  
Give the drive a step change in speed reference and monitor the response of the drive on the oscilloscope.  
The proportional gain (Kp) should be set up initially. The value should be increased up to the point where the speed overshoots and then reduced slightly.  
The integral gain (Ki) should then be increased up to the point where the speed becomes unstable and then reduced slightly.  
It may now be possible to increase the proportional gain to a higher value and the process should be repeated until the system response matches the ideal response as shown.  
The diagram shows the effect of incorrect P and I gain settings as well as the ideal response.
2. Pr 03.017 = 1, Bandwidth set-up  
If bandwidth based set-up is required, the drive can calculate Kp and Ki if the following parameters are set up correctly:  
Pr 03.020 - Required bandwidth,  
Pr 03.021 - Required damping factor,  
Pr 03.018 - Motor and load inertia.  
The drive can be made to measure the motor and load inertia by performing an inertia measurement autotune (see Autotune Pr 00.040, earlier in this table).
3. Pr 03.017 = 2, Compliance angle set-up  
If compliance angle based set-up is required, the drive can calculate Kp and Ki if the following parameters are set up correctly:  
Pr 03.019 - Required compliance angle,  
Pr 03.021 - Required damping factor,  
Pr 03.018 - Motor and load inertia  
The drive can be made to measure the motor and load inertia by performing an inertia measurement autotune (see Autotune Pr 00.040, earlier in this table).
4. Pr 03.017 = 3, Kp gains times 16  
If Speed Controller Set-up Method (03.017) = 3 the selected proportional gain used by the drive is multiplied by 16.



#### 5. Pr 03.017 = 4 - 6

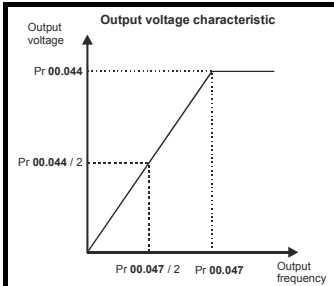
If Speed Controller Set-up Method (03.017) is set to a value from 4 to 6 the Speed Controller Proportional Gain Kp1 Pr 00.007 {03.010} and Speed Controller Integral Gain Ki1 Pr 00.008 {03.011} are automatically set up to give the bandwidths given in the table below and a damping factor of unity. These settings give low, standard or high performance.

Pr 03.017	Performance	Bandwidth
4	Low	5 Hz
5	Standard	25 Hz
6	High	100 Hz

#### 6. Pr 03.017 = 7

If Speed Controller Set-up Method (03.017) = 7 then Speed Controller Proportional Gain Kp1 Pr 00.007 {03.010}, Speed Controller Integral Gain Ki1 Pr 00.008 {03.011} and Speed Controller Differential Feedback Gain Kd1 Pr 00.009 {03.012} are set up to give a closed-loop speed controller response that approximates to a first order system with a transfer function of  $1 / (st + 1)$ , where  $t = 1/wbw$  and  $wbw = 2\pi \times \text{Bandwidth}$  (03.020). In this case the damping factor is meaningless, and Damping Factor (03.021) and Compliance Angle (03.019) have no effect.

### 8.1.3 Open loop motor control

<p><b>Pr 00.046 {05.007} Rated Current</b></p> <p>The motor rated current parameter must be set to the maximum continuous current of the motor. The motor rated current is used in the following:</p> <ul style="list-style-type: none"> <li>• Current limits (see section 8.2 <i>Current limits</i> on page 91, for more information)</li> <li>• Motor thermal overload protection (see section 8.3 <i>Motor thermal protection</i> on page 91, for more information)</li> <li>• Vector mode voltage control (see <i>Open Loop Control Mode</i> (00.007), later in this table)</li> <li>• Slip compensation (see <i>Enable Slip Compensation</i> (05.027), later in this table)</li> <li>• Dynamic V/F control</li> </ul>	<p><b>Defines the maximum continuous motor current</b></p>
<p><b>Pr 00.044 {05.009} Rated Voltage</b></p> <p><b>Pr 00.047 {05.006} Rated Frequency</b></p>	<p><b>Defines the voltage applied to the motor at rated frequency</b></p> <p><b>Defines the frequency at which rated voltage is applied</b></p>
<p>The <i>Rated Voltage</i> (00.044) and the <i>Rated Frequency</i> (00.047) are used to define the voltage to frequency characteristic applied to the motor (see <i>Open Loop Control Mode</i> (00.007), later in this table). The <i>Rated Frequency</i> (00.047) is also used in conjunction with the motor rated speed to calculate the rated slip for slip compensation (see <i>Rated Speed</i> (00.045), later in this table).</p>	
<p><b>Pr 00.045 {05.008} Rated Speed</b></p> <p><b>Pr 00.042 {05.011} Number Of Motor Poles</b></p>	<p><b>Defines the full load rated speed of the motor</b></p> <p><b>Defines the number of motor poles</b></p>
<p>The motor rated speed and the number of poles are used with the motor rated frequency to calculate the rated slip of induction machines in Hz.</p> $\text{Rated slip (Hz)} = \text{Motor rated frequency} - (\text{Number of pole pairs} \times [\text{Motor rated speed} / 60]) = \mathbf{00.047} = \left( \frac{\mathbf{00.042}}{2} \times \frac{\mathbf{00.045}}{60} \right)$ <p>If <b>Pr 00.045</b> is set to 0 or to synchronous speed, slip compensation is disabled. If slip compensation is required this parameter should be set to the nameplate value, which should give the correct rpm for a hot machine. Sometimes it will be necessary to adjust this when the drive is commissioned because the nameplate value may be inaccurate. Slip compensation will operate correctly both below base speed and within the field-weakening region. Slip compensation is normally used to correct for the motor speed to prevent speed variation with load. The rated load rpm can be set higher than synchronous speed to deliberately introduce speed droop. This can be useful to aid load sharing with mechanically coupled motors.</p> <p><b>Pr 00.042</b> is also used in the calculation of the motor speed display by the drive for a given output frequency. When <b>Pr 00.042</b> is set to 'Automatic', the number of motor poles is automatically calculated from the rated frequency <b>Pr 00.047</b>, and the motor rated speed <b>Pr 00.045</b>.</p> $\text{Number of poles} = 120 \times (\text{Rated Frequency (00.047)} / \text{Rated Speed (00.045)}) \text{ rounded to the nearest even number.}$	
<p><b>Pr 00.043 {05.010} Rated Power Factor</b></p>	<p><b>Defines the angle between the motor voltage and current</b></p> <p>The power factor is the true power factor of the motor, i.e. the angle between the motor voltage and current. The power factor is used in conjunction with the <i>Rated Current</i> (00.046), to calculate the rated active current and magnetising current of the motor. The rated active current is used extensively to control the drive, and the magnetising current is used in vector mode stator resistance compensation. It is important that this parameter is set up correctly. The drive can measure the motor rated power factor by performing a rotating autotune (see Autotune (Pr 00.040), overleaf).</p>
<p><b>Pr 00.040 {05.012} Autotune</b></p> <p>There are two autotune tests available in open loop mode, a stationary and a rotating test. A rotating autotune should be used whenever possible so the measured value of power factor of the motor is used by the drive.</p> <ul style="list-style-type: none"> <li>• A stationary autotune can be used when the motor is loaded and it is not possible to remove the load from the motor shaft. The stationary test measures the <i>Stator Resistance</i> (05.017), <i>Transient Inductance</i> (05.024), <i>Maximum Deadtime Compensation</i> (05.059) and <i>Current At Maximum Deadtime Compensation</i> (05.060) which are required for good performance in vector control modes (see <i>Open Loop Control Mode</i> (00.007), later in this table). The stationary autotune does not measure the power factor of the motor so the value on the motor nameplate must be entered into <b>Pr 00.043</b>. To perform a Stationary autotune, set <b>Pr 00.040</b> to 1, and provide the drive with both an enable signal (terminal 2 &amp; 6) and a run signal (terminal 11 or 13).</li> <li>• A rotating autotune should only be used if the motor is unloaded. A rotating autotune first performs a stationary autotune, as above, then a rotating test is performed in which the motor is accelerated with currently selected ramps up to a frequency of <i>Rated Frequency</i> (05.006) x 2/3, and the frequency is maintained at that level for 4 seconds. <i>Stator Inductance</i> (05.025) is measured and this value is used in conjunction with other motor parameters to calculate <i>Rated Power Factor</i> (05.010). To perform a Rotating autotune, set <b>Pr 00.040</b> to 2, and provide the drive with both an enable signal (terminal 2 &amp; 6) and a run signal (terminal 11 or 13).</li> </ul> <p>Following the completion of an autotune test the drive will go into the inhibit state. The drive must be placed into a controlled disable condition before the drive can be made to run at the required reference. The drive can be put in to a controlled disable condition by removing the Safe Torque Off signal from terminal 2 &amp; 6, setting the <i>Drive Enable</i> (06.015) to OFF (0) or disabling the drive via the <i>Control Word</i> (06.042) and <i>Control Word Enable</i> (06.043).</p>	

### Pr 00.007 {05.014} Open Loop Control Mode

There are several voltage modes available which fall into two categories, vector control and fixed boost.

#### Vector control

Vector control mode provides the motor with a linear voltage characteristic from 0 Hz to motor *Rated Frequency* (00.047), and then a constant voltage above motor rated frequency. When the drive operates between motor rated frequency/50 and motor rated frequency/4, full vector based stator resistance compensation is applied. When the drive operates between motor rated frequency/4 and motor rated frequency/2 the stator resistance compensation is gradually reduced to zero as the frequency increases. For the vector modes to operate correctly the *Rated Power Factor* (00.043), *Stator Resistance* (05.017) are all required to be set up accurately. The drive can be made to measure these by performing an autotune (see Pr 00.040 *Autotune*). The drive can also be made to measure the stator resistance automatically every time the drive is enabled or the first time the drive is enabled after it is powered up, by selecting one of the vector control voltage modes.

(0) **Ur S** = The stator resistance is measured and the parameter for the selected motor map is over-written each time the drive is made to run. This test can only be done with a stationary motor where the flux has decayed to zero. Therefore this mode should only be used if the motor is guaranteed to be stationary each time the drive is made to run. To prevent the test from being done before the flux has decayed there is a period of 1 second after the drive has been in the ready state during which the test is not done if the drive is made to run again. In this case, previously measured values are used. Ur S mode ensures that the drive compensates for any change in motor parameters due to changes in temperature. The new value of stator resistance is not automatically saved to the drive's EEPROM.

(1) **Ur** = The stator resistance is not measured. The user can enter the motor and cabling resistance into the *Stator Resistance* (05.017). However this will not include resistance effects within the drive inverter. Therefore if this mode is to be used, it is best to use an autotune test initially to measure the stator resistance.

(3) **Ur\_Auto** = The stator resistance is measured once, the first time the drive is made to run. After the test has been completed successfully the *Open Loop Control Mode* (00.007) is changed to Ur mode. The *Stator Resistance* (05.017) parameter is written to, and along with the *Open Loop Control Mode* (00.007), are saved in the drive's EEPROM. If the test fails, the voltage mode changes to Ur mode but *Stator Resistance* (05.017) is not updated.

(4) **Ur I** = The stator resistance is measured when the drive is first made to run after each power-up. This test can only be done with a stationary motor. Therefore this mode should only be used if the motor is guaranteed to be stationary the first time the drive is made to run after each power-up. The new value of stator resistance is not automatically saved to the drive's EEPROM.

### Pr 00.007 {05.014} Open Loop Control Mode (cont)

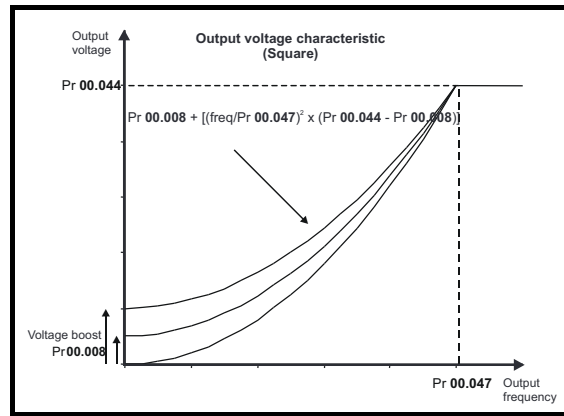
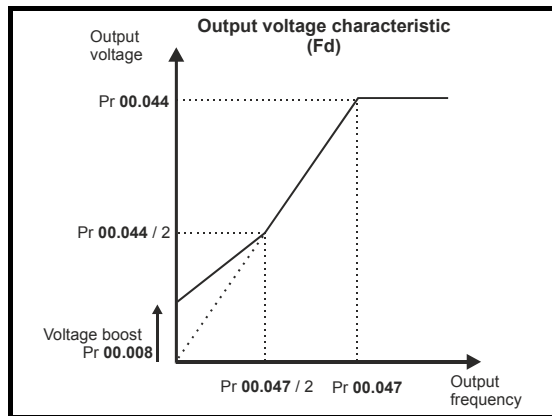
#### Fixed boost

The stator resistance is not used in the control of the motor, instead a fixed characteristic with low frequency voltage boost as defined by parameter Pr **00.008**, is used. Fixed boost mode should be used when the drive is controlling multiple motors. There are two settings of fixed boost available:

(2) **Fixed** = This mode provides the motor with a linear voltage characteristic from 0 Hz to *Rated Frequency* (00.047), and then a constant voltage above rated frequency.

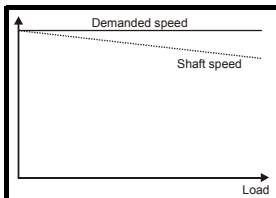
(5) **Square** = This mode provides the motor with a square law voltage characteristic from 0 Hz to *Rated Frequency* (00.047), and then a constant voltage above rated frequency. This mode is suitable for variable torque applications like fans and pumps where the load is proportional to the square of the speed of the motor shaft. This mode should not be used if a high starting torque is required.

For both these modes, at low frequencies (from 0Hz to 1/2 x Pr **00.047**) a voltage boost is applied defined by Pr **00.008** as shown below:



### Pr 05.027 Enable Slip Compensation

When a motor, being controlled in open loop mode, has load applied a characteristic of the motor is that the output speed droops in proportion to the load applied as shown:



In order to prevent the speed droop shown above slip compensation should be enabled. To enable slip compensation Pr **05.027** must be set to a 1 (this is the default setting), and the motor rated speed must be entered in Pr **00.045** (Pr **05.008**).

The motor rated speed parameter should be set to the synchronous speed of the motor minus the slip speed. This is normally displayed on the motor nameplate, i.e. for a typical 18.5 kW, 50 Hz, 4 pole motor, the motor rated speed would be approximately 1465 rpm. The synchronous speed for a 50 Hz, 4 pole motor is 1500 rpm, so therefore the slip speed would be 35 rpm. If the synchronous speed is entered in Pr **00.045**, slip compensation will be disabled. If too small a value is entered in Pr **00.045**, the motor will run faster than the demanded frequency. The synchronous speeds for 50 Hz motors with different numbers of poles are as follows:

2 pole = 3000 rpm, 4 pole = 1500 rpm, 6 pole = 1000 rpm, 8 pole = 750 rpm

## 8.1.4 RFC-A mode

### Induction motor with Position feedback

<b>Pr 00.046 {05.007} Motor Rated Current</b>	<b>Defines the maximum motor continuous current</b>
<p>The motor rated current parameter must be set to the maximum continuous current of the motor. The motor rated current is used in the following:</p> <ul style="list-style-type: none"> <li>• Current limits (see section 8.2 <i>Current limits</i> on page 91, for more information).</li> <li>• Motor thermal overload protection (see section 8.3 <i>Motor thermal protection</i> on page 91, for more information)</li> <li>• Vector control algorithm</li> </ul>	
<b>Pr 00.044 {05.009} Rated Voltage</b>	<b>Defines the voltage applied to the motor at rated frequency</b>
<b>Pr 00.047 {05.006} Rated Frequency</b>	<b>Defines the frequency at which rated voltage is applied</b>
<p>The <i>Rated Voltage</i> (00.044) and the <i>Rated Frequency</i> (00.047) are used to define the voltage to frequency characteristic applied to the motor (see <i>Open Loop Control Mode</i> (00.007), detailed in section 8.1.3). The motor rated frequency is also used in conjunction with the motor rated speed to calculate the rated slip for slip compensation (see motor <i>Rated Speed</i> (00.045), later in this table).</p>	
<p>The graph, titled 'Output voltage characteristic', plots Output voltage on the y-axis against Output frequency on the x-axis. A solid line starts at the origin (0,0) and rises linearly. A dashed vertical line at frequency <math>Pr\ 00.047 / 2</math> meets the line at a voltage of <math>Pr\ 00.044 / 2</math>. Another dashed vertical line at frequency <math>Pr\ 00.047</math> meets the line at a voltage of <math>Pr\ 00.044</math>. From this point, the line continues horizontally to the right, indicating constant output voltage for frequencies above the rated frequency.</p>	
<b>Pr 00.045 {05.008} Rated Speed</b>	<b>Defines the full load rated speed of the motor</b>
<b>Pr 00.042 {05.011} Number Of Motor Poles</b>	<b>Defines the number of motor poles</b>
<p>The motor rated speed and motor rated frequency are used to determine the full load slip of the motor which is used by the vector control algorithm. Incorrect setting of this parameter has the following effects:</p> <ul style="list-style-type: none"> <li>• Reduced efficiency of motor operation</li> <li>• Reduction of maximum torque available from the motor</li> <li>• Reduced transient performance</li> <li>• Inaccurate control of absolute torque in torque control modes</li> </ul> <p>The nameplate value is normally the value for a hot motor; however, some adjustment may be required when the drive is commissioned if the nameplate value is inaccurate. Either a fixed value can be entered in this parameter or an optimization system may be used to automatically adjust this parameter (see <i>Rated Speed Optimisation Select</i> (00.033), later in this table).</p> <p>When Pr <b>00.042</b> is set to 'Automatic', the number of motor poles is automatically calculated from the motor <i>Rated Frequency</i> (00.047), and the motor <i>Rated Speed</i> (00.045).</p> <p>Number of poles = <math>120 \times (\text{Motor Rated Frequency (00.047)} / \text{Motor Rated Speed (00.045)})</math> rounded to the nearest even number.</p>	
<b>Pr 00.043 {5.10} Rated Power Factor</b>	<b>Defines the angle between the motor voltage and current</b>
<p>The power factor is the true power factor of the motor, i.e. the angle between the motor voltage and current. If the <i>Stator Inductance</i> (05.025) is set to zero then the power factor is used in conjunction with the motor <i>Rated Current</i> (00.046) and other motor parameters to calculate the rated active and magnetising currents of the motor, which are used in the vector control algorithm. If the stator inductance has a non-zero value this parameter is not used by the drive, but is continuously written with a calculated value of power factor. The stator inductance can be measured by the drive by performing a rotating autotune (see <i>Autotune</i> (Pr <b>00.040</b>), later in this table).</p>	

## Pr 00.040 {05.012} Autotune

There are four autotune tests available in RFC-A mode, a stationary autotune, a rotating autotune, two mechanical load measurement tests. A stationary autotune will give moderate performance whereas a rotating autotune will give improved performance as it measures the actual values of the motor parameters required by the drive. A mechanical load measurement test should be performed separately to a stationary or rotating autotune.

### NOTE

It is highly recommended that a rotating autotune is performed (Pr 00.040 set to 2).

- A stationary autotune can be used when the motor is loaded and it is not possible to remove the load from the motor shaft. The stationary autotune measures the *Stator Resistance* (05.017) and *Transient Inductance* (05.024) of the motor. These are used to calculate the current loop gains, and at the end of the test the values in Pr 00.038 and Pr 00.039 are updated. A stationary autotune does not measure the power factor of the motor so the value on the motor nameplate must be entered into Pr 00.043. To perform a Stationary autotune, set Pr 00.040 to 1, and provide the drive with both an enable signal (terminal 2 & 6) and a run signal (terminal 11 or 13).
- A rotating autotune should only be used if the motor is unloaded. A rotating autotune first performs a stationary autotune, a rotating test is then performed which the motor is accelerated with currently selected ramps up to a frequency of *Rated Frequency* (00.047) x 2/3, and the frequency is maintained at the level for up to 40 s. During the rotating autotune the *Stator Inductance* (05.025), and the motor saturation breakpoints (Pr 05.029, Pr 05.030, Pr 06.062 and Pr 05.063) are modified by the drive. The *Motor Rated Power Factor* (00.043) is also modified by the *Stator Inductance* (05.025). The No-Load motor core losses are measured and written to *No-Load Core Losses* (04.045). To perform a Rotating autotune, set Pr 00.040 to 2, and provide the drive with both an enable signal (terminal 2 & 6) and a run signal (terminal 11 or 13).
- Mechanical load measurement test using signal injection.  
This test measures the mechanical characteristic of the motor and load by rotating the motor at the speed defined by the present speed reference and injecting a series of speed test signals. This test should only be used provided all the basic control parameters have been set-up correctly and the speed controller parameters should be set to conservative levels, such as the default values, so that the motor is stable when it runs. The test measures the motor and load inertia, which can be used in automatic set-up of the speed controller gains and in producing a torque feed-forward term. If *Mechanical Load Test Level* (05.021) is left at its default value of zero then the peak level of the injection signal will be 1 % of the maximum speed reference subject to a maximum of 500 rpm. If a different test level is required then *Mechanical Load Test Level* (05.021) should be set to a non-zero value to define the level as a percentage of the maximum speed reference, again subject to a maximum of 500 rpm. The user defined speed reference which defines the speed of the motor should be set to a level higher than the test level, but not high enough for flux weakening to become active. In some cases however, it is possible to perform the test at zero speed provided the motor is free to move, but it may be necessary to increase the test signal from the default value. The test will give the correct results when there is a static load applied to the motor and in the presence of mechanical damping. This test should be used if possible, however for sensorless mode, or if the speed controller cannot be set up for stable operation an alternative test is provided (*Autotune* (00.040) = 4) where a series of torque levels are applied to accelerate and decelerate the motor to measure the inertia.
  - A rotating test is performed in which the motor is accelerated with the currently selected ramps up to the currently selected speed reference, and this speed is maintained for the duration of the test. The *Motor And Load Inertia* (03.018) is set-up.

To perform this autotune test, set Pr 00.040 to 3 and provide the drive with both an enable signal (terminal 2 & 6) and a run signal (terminal 11 or 13).

- Mechanical load measurement test using applied torque.*

Auto-tune test 3 should normally be used for mechanical load measurement, but under some circumstances this test may be used as an alternative. This test will not give such accurate results as test 3 if the motor rated speed is not set to the correct value for the motor. Also this test is likely to give incorrect results if standard ramp mode is active. A series of progressively larger torque levels are applied to the motor (20 %, 40 % ... 100 % of rated torque) to accelerate the motor up to 3/4 x *Rated Speed* (00.045) to determine the inertia from the acceleration/deceleration time. The test attempts to reach the required speed within 5 s, but if this fails the next torque level is used. When 100 % torque is used the test allows 60 s for the required speed to be reached, but if this is unsuccessful, an *Autotune 1* trip is initiated. To reduce the time taken for the test it is possible to define the level of torque to be used for the test by setting *Mechanical Load Test Level* (05.021) to a non-zero value. When the test level is defined the test is only carried out at the defined test level and 60 s is allowed for the motor to reach the required speed. It should be noted that if the maximum speed allows for flux weakening then it may not be possible to achieve the required torque level to accelerate the motor fast enough. If this is the case, the maximum speed reference should be reduced.

- The motor is accelerated in the required direction up to 3/4 of the maximum speed reference and then decelerated to zero speed.
- The test is repeated with progressively higher torques until the required speed is reached.
- Motor And Load Inertia* (03.018) and *Inertia Times 1000* (04.033) are set up.

To perform this autotune test, set Pr 00.040 to 4 and provide the drive with both an enable signal (terminal 2 & 6) and a run signal (terminal 11 or 13).

Following the completion of an autotune test the drive will go into the inhibit state. The drive must be placed into a controlled disable condition before the drive can be made to run at the required reference. The drive can be put in to a controlled disable condition by removing the Safe Torque Off signal from terminal 2 & 6, setting the *Drive Enable* (06.015) to Off (0) or disabling the drive via the control word (Pr 06.042 & Pr 06.043).

## Pr 00.033 {05.016} Rated Speed Optimisation Select

The *Rated Frequency* (00.047) and *Rated Speed* (00.045) are used to define the rated slip of the motor. The rated slip is used in sensorless mode (*Sensorless Mode Active* (03.078) = 1) to correct the motor speed with load. When this mode is active *Rated Speed Optimisation Select* (00.033) has no effect.

If sensorless mode is not active (*Sensorless Mode Active* (03.078) = 0) the rated slip is used in the motor control algorithm and an incorrect value of slip can have a significant effect on the motor performance. If *Rated Speed Optimisation Select* (00.033) = 0 then the adaptive control system is disabled. However, if *Rated Speed Optimisation Select* (00.033) is set to a non-zero value the drive can automatically adjust the *Rated Speed* (00.045) to give the correct value of rated slip. *Rated Speed* (00.045) is not saved at power-down, and so when the drive is powered-down and up again it will return to the last value saved by the user. The rate of convergence and the accuracy of the adaptive controller reduces at low output frequency and low load. The minimum frequency is defined as a percentage of *Rated Frequency* (00.047) by *Rated Speed Optimisation Minimum Frequency* (05.019). The minimum load is defined as a percentage of rated load by *Rated Speed Optimisation Minimum Load* (05.020). The adaptive controller is enabled when a motoring or regenerative load rises above *Rated Speed Optimisation Minimum Load* (05.020) + 5%, and is disabled again when it falls below *Rated Speed Optimisation Minimum Load* (05.020). For best optimisation results the correct values of *Stator Resistance* (05.017), *Transient Inductance* (05.024), *Stator Inductance* (05.025), *Saturation Breakpoint 1* (05.029), *Saturation Breakpoint 2* (05.062), *Saturation Breakpoint 3* (05.030) and *Saturation Breakpoint 4* (05.063) should be used.

**Pr 00.038 {04.013} / Pr 00.039 {04.014} Current Loop Gains**

The current loop gains proportional (Kp) and integral (Ki) gains control the response of the current loop to a change in current (torque) demand. The default values give satisfactory operation with most motors. However, for optimal performance in dynamic applications it may be necessary to change the gains to improve the performance. The *Current Controller Kp Gain* (00.038) is the most critical value in controlling the performance. The values for the current loop gains can be calculated by performing a stationary or rotating autotune (see *Autotune* Pr 00.040, earlier in this table) the drive measures the *Stator Resistance* (05.017) and *Transient Inductance* (05.024) of the motor and calculates the current loop gains.

This will give a step response with minimum overshoot after a step change of current reference. The proportional gain can be increased by a factor of 1.5 giving a similar increase in bandwidth; however, this gives a step response with approximately 12.5 % overshoot. The equation for the integral gain gives a conservative value. In some applications where it is necessary for the reference frame used by the drive to dynamically follow the flux very closely (i.e. high speed Sensorless RFC-A induction motor applications) the integral gain may need to have a significantly higher value.

### Speed Loop Gains (Pr 00.007 {03.010}, Pr 00.008 {03.011}, Pr 00.009 {03.012})

The speed loop gains control the response of the speed controller to a change in speed demand. The speed controller includes proportional (Kp) and integral (Ki) feed forward terms, and a differential (Kd) feedback term. The drive holds two sets of these gains and either set may be selected for use by the speed controller with Pr 03.016. If Pr 03.016 = 0, gains Kp1, Ki1 and Kd1 (Pr 00.007 to Pr 00.009) are used, and if Pr 03.016 = 1, gains Kp2, Ki2 and Kd2 (Pr 03.013 to Pr 03.015) are used. Pr 03.016 may be changed when the drive is enabled or disabled. If the load is predominantly a constant inertia and constant torque, the drive can calculate the required Kp and Ki gains to give a required compliance angle or bandwidth dependant on the setting of Pr 03.017.

#### Speed Controller Proportional Gain (Kp), Pr 00.007 {03.010} and Pr 03.013

If the proportional gain has a value and the integral gain is set to zero the controller will only have a proportional term, and there must be a speed error to produce a torque reference. Therefore as the motor load increases there will be a difference between the reference and actual speeds. This effect, called regulation, depends on the level of the proportional gain, the higher the gain the smaller the speed error for a given load. If the proportional gain is too high either the acoustic noise produced by speed feedback quantization becomes unacceptable, or the stability limit is reached.

#### Speed Controller Integral Gain (Ki), Pr 00.008 {03.011} and Pr 03.014

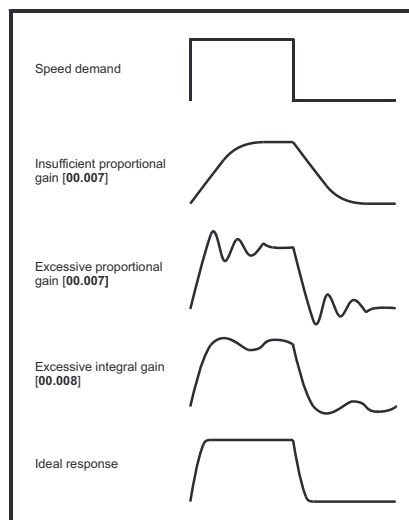
The integral gain is provided to prevent speed regulation. The error is accumulated over a period of time and used to produce the necessary torque demand without any speed error. Increasing the integral gain reduces the time taken for the speed to reach the correct level and increases the stiffness of the system, i.e. it reduces the positional displacement produced by applying a load torque to the motor. Unfortunately increasing the integral gain also reduces the system damping giving overshoot after a transient. For a given integral gain the damping can be improved by increasing the proportional gain. A compromise must be reached where the system response, stiffness and damping are all adequate for the application. For RFC-A Sensorless mode, it is unlikely that the integral gain can be increased much above 0.50.

#### Differential Gain (Kd), Pr 00.009 {03.012} and Pr 03.015

The differential gain is provided in the feedback of the speed controller to give additional damping. The differential term is implemented in a way that does not introduce excessive noise normally associated with this type of function. Increasing the differential term reduces the overshoot produced by under-damping, however, for most applications the proportional and integral gains alone are sufficient.

There are six methods of tuning the speed loop gains dependant on the setting of Pr 03.017:

- Pr 03.017 = 0, User set-up.  
This involves the connecting of an oscilloscope to analog output 1 to monitor the speed feedback.  
Give the drive a step change in speed reference and monitor the response of the drive on the oscilloscope.  
The proportional gain (Kp) should be set up initially. The value should be increased up to the point where the speed overshoots and then reduced slightly.  
The integral gain (Ki) should then be increased up to the point where the speed becomes unstable and then reduced slightly.  
It may now be possible to increase the proportional gain to a higher value and the process should be repeated until the system response matches the ideal response as shown.  
The diagram shows the effect of incorrect P and I gain settings as well as the ideal response.
- Pr 03.017 = 1, Bandwidth set-up  
If bandwidth based set-up is required, the drive can calculate Kp and Ki if the following parameters are set up correctly:  
Pr 03.020 - Required bandwidth,  
Pr 03.021 - Required damping factor,  
Pr 03.018 - Motor and load inertia.  
The drive can be made to measure the motor and load inertia by performing a mechanical load measurement autotune (see *Autotune* Pr 00.040, earlier in this table).
- Pr 03.017 = 2, Compliance angle set-up  
If compliance angle based set-up is required, the drive can calculate Kp and Ki if the following parameters are set up correctly:  
Pr 03.019 - Required compliance angle,  
Pr 03.021 - Required damping factor,  
Pr 03.018 - Motor and load inertia The drive can be made to measure the motor and load inertia by performing a mechanical load measurement autotune (see *Autotune* Pr 00.040, earlier in this table).
- Pr 03.017 = 3, Kp gains times 16  
If *Speed Controller Set-up Method* (03.017) = 3 the selected proportional gain used by the drive is multiplied by 16.



#### Pr 03.017 = 4 - 6

If *Speed Controller Set-up Method* (03.017) is set to a value from 4 to 6 the *Speed Controller Proportional Gain Kp1* (03.010) and *Speed Controller Integral Gain Ki1* (03.011) are automatically set up to give the bandwidths given in the table below and a damping factor of unity. These settings give low, standard or high performance.

Speed Controller Set-up Method (03.017)	Performance	Bandwidth
4	Low	5 Hz
5	Standard	25 Hz
6	High	100 Hz

#### 6. Pr 03.017 = 7

If *Speed Controller Set-up Method* (03.017) = 7 then *Speed Controller Proportional Gain Kp1* (03.010), *Speed Controller Integral Gain Ki1* (03.011) and *Speed Controller Differential Feedback Gain Kd1* (03.012) are set up to give a closed-loop speed controller response that approximates to a first order system with a transfer function of  $1 / (s\tau + 1)$ , where  $\tau = 1/\omega_{bw}$  and  $\omega_{bw} = 2\pi \times \text{Bandwidth}$  (03.020). In this case the damping factor is meaningless, and *Damping Factor* (03.021) and *Compliance Angle* (03.019) have no effect.

## 8.1.5 RFC-A Sensorless mode

### Induction motor without position feedback

<b>Pr 00.046 {05.007} Motor Rated Current</b>	<b>Defines the maximum motor continuous current</b>
<p>The motor rated current parameter must be set to the maximum continuous current of the motor. The motor rated current is used in the following:</p> <ul style="list-style-type: none"> <li>• Current limits (see section 8.2 <i>Current limits</i> on page 91, for more information).</li> <li>• Motor thermal overload protection (see section 8.3 <i>Motor thermal protection</i> on page 91, for more information)</li> <li>• Vector control algorithm</li> </ul>	
<b>Pr 00.044 {05.009} Rated Voltage</b>	<b>Defines the voltage applied to the motor at rated frequency</b>
<b>Pr 00.047 {05.006} Rated Frequency</b>	<b>Defines the frequency at which rated voltage is applied</b>
<p>The <i>Rated Voltage</i> (00.044) and the <i>Rated Frequency</i> (00.047) are used to define the voltage to frequency characteristic applied to the motor (see <i>Open Loop Control Mode</i> (00.007), later in this table). The motor rated frequency is also used in conjunction with the motor rated speed to calculate the rated slip for slip compensation (see motor <i>Rated Speed</i> (00.045), later in this table).</p>	
<p>The graph, titled 'Output voltage characteristic', plots Output voltage on the y-axis against Output frequency on the x-axis. The curve starts at the origin (0,0) and rises linearly to a point where the frequency is Pr 00.047 / 2 and the voltage is Pr 00.044 / 2. From this point, the curve continues as a horizontal line until the frequency reaches Pr 00.047, where the voltage is Pr 00.044. For frequencies greater than Pr 00.047, the output voltage remains constant at the value Pr 00.044.</p>	
<b>Pr 00.045 {05.008} Rated Speed</b>	<b>Defines the full load rated speed of the motor</b>
<b>Pr 00.042 {05.011} Number Of Motor Poles</b>	<b>Defines the number of motor poles</b>
<p>The motor rated speed and motor rated frequency are used to determine the full load slip of the motor which is used by the vector control algorithm. Incorrect setting of this parameter has the following effects:</p> <ul style="list-style-type: none"> <li>• Reduced efficiency of motor operation</li> <li>• Reduction of maximum torque available from the motor</li> <li>• Reduced transient performance</li> <li>• Inaccurate control of absolute torque in torque control modes</li> </ul> <p>The nameplate value is normally the value for a hot motor; however, some adjustment may be required when the drive is commissioned if the nameplate value is inaccurate. Either a fixed value can be entered in this parameter or an optimization system may be used to automatically adjust this parameter (see <i>Rated Speed Optimization Select</i> (05.016), later in this table).</p> <p>When Pr 00.042 is set to 'Automatic', the number of motor poles is automatically calculated from the motor <i>Rated Frequency</i> (00.047), and the motor <i>Rated Speed</i> (00.045).</p> <p>Number of poles = <math>120 \times (\text{Motor Rated Frequency (00.047)} / \text{Motor Rated Speed (00.045)}) / \text{Motor}</math> rounded to the nearest even number.</p>	
<b>Pr 00.043 {5.010} Rated Power Factor</b>	<b>Defines the angle between the motor voltage and current</b>
<p>The power factor is the true power factor of the motor, i.e. the angle between the motor voltage and current. If the <i>Stator Inductance</i> (05.025) is set to zero then the power factor is used in conjunction with the motor <i>Rated Current</i> (00.046) and other motor parameters to calculate the rated active and magnetising currents of the motor, which are used in the vector control algorithm. If the stator inductance has a non-zero value this parameter is not used by the drive, but is continuously written with a calculated value of power factor. The stator inductance can be measured by the drive by performing a rotating autotune (see <i>Autotune</i> (Pr 00.040), later in this table).</p>	

## Pr 00.040 {05.012} Autotune

There are three autotune tests available in RFC-A mode, a stationary test, a rotating test and a mechanical load measurement test. A stationary autotune will give moderate performance whereas a rotating autotune will give improved performance as it measures the actual values of the motor parameters required by the drive. A mechanical load measurement test should be performed separately to a stationary or rotating autotune.

It is highly recommended that a rotating autotune is performed (Pr 00.040 set to 2).

- A stationary autotune can be used when the motor is loaded and it is not possible to remove the load from the motor shaft. The stationary autotune measures the *Stator Resistance* (05.017) and *Transient Inductance* (05.024) of the motor. These are used to calculate the current loop gains, and at the end of the test the values in Pr 00.038 and Pr 00.039 are updated. *Maximum Deadtime Compensation* (05.059) and *Current At Maximum Deadtime Compensation* (05.060) for the drive are also measured. Additionally, if *Enable Stator Compensation* (05.049) = 1, then *Stator Base Temperature* (05.048) is made equal to *Stator Temperature* (05.046). A stationary autotune does not measure the power factor of the motor so the value on the motor nameplate must be entered into Pr 00.043. To perform a stationary autotune, set Pr 00.040 to 1, and provide the drive with both an enable signal (terminal 2 & 6) and a run signal (terminal 11 or 13).
- A rotating autotune should only be used if the motor is unloaded. A rotating autotune first performs a stationary autotune, a rotating test is then performed in which the motor is accelerated with currently selected ramps up to a frequency of *Rated Frequency* (00.047) x 2/3, and the frequency is maintained at the level for up to 40 s. During the rotating autotune the *Stator Inductance* (05.025), and the motor saturation breakpoints (Pr 05.029, Pr 05.030, Pr 06.062 and Pr 05.063) are modified by the drive. The power factor is also modified for user information only, but is not used after this point as the stator inductance is used in the vector control algorithm instead. To perform a Rotating autotune, set Pr 00.040 to 2, and provide the drive with both an enable signal (terminal 2 & 6) and a run signal (terminal 11 or 13).
- The mechanical load measurement test can measure the total inertia of the load and the motor. This is used to set the speed loop gains (see Speed loop gains) and to provide torque feed-forwards when required during acceleration.  
**Applied torque (sensorless mode)** This test may give inaccurate results, if the motor rated speed is not set to the correct value for the motor, or if standard ramp mode is active. During the mechanical load measurement test a series of progressively larger torque levels are applied to the motor (20 %, 40 % ... 100 % of rated torque) to accelerate the motor up to  $\frac{3}{4} \times \text{Rated Speed}$  (00.045) to determine the inertia from the acceleration/deceleration time. The test attempts to reach the required speed within 5 s, but if this fails the next torque level is used. When 100 % torque is used the test allows 60 s for the required speed to be reached, but if this is unsuccessful an Autotune 1 trip is initiated. To reduce the time taken for the test it is possible to define the level of torque to be used for the test by setting *Mechanical Load Test Level* (05.021) to a non-zero value. When the test level is defined the test is only carried out at the defined test level and 60 s is allowed for the motor to reach the required speed. It should be noted that if the maximum speed allows for flux weakening then it may not be possible to achieve the required torque level to accelerate the motor quickly enough. If this is the case, the maximum speed reference should be reduced. To perform a mechanical load measurement autotune, set Pr 00.040 to 4, and provide the drive with both an enable signal (terminal 2 & 6) and a run signal (terminal 11 or 13).

Following the completion of an autotune test the drive will go into the inhibit state. The drive must be placed into a controlled disable condition before the drive can be made to run at the required reference. The drive can be put in to a controlled disable condition by removing the Safe Torque Off signal from terminal 2 & 6, setting the *Drive Enable* (06.015) to OFF (0) or disabling the drive via the control word (Pr 06.042 & Pr 06.043).

## Pr 00.038 {04.013} / Pr 00.039 {04.014} Current Loop Gains

The current loop gains proportional (Kp) and integral (Ki) gains control the response of the current loop to a change in current (torque) demand. The default values give satisfactory operation with most motors. However, for optimal performance in dynamic applications it may be necessary to change the gains to improve the performance. The *Current Controller Kp Gain* (00.038) is the most critical value in controlling the performance. The values for the current loop gains can be calculated by performing a stationary or rotating autotune (see *Autotune* Pr 00.040, earlier in this table) the drive measures the *Stator Resistance* (05.017) and *Transient Inductance* (05.024) of the motor and calculates the current loop gains.

This will give a step response with minimum overshoot after a step change of current reference. The proportional gain can be increased by a factor of 1.5 giving a similar increase in bandwidth; however, this gives a step response with approximately 12.5 % overshoot. The equation for the integral gain gives a conservative value. In some applications where it is necessary for the reference frame used by the drive to dynamically follow the flux very closely (i.e. high speed Sensorless RFC-A induction motor applications) the integral gain may need to have a significantly higher value.

### Speed Loop Gains (Pr 00.007 {03.010}, Pr 00.008 {03.011}, Pr 00.009 {03.012})

The speed loop gains control the response of the speed controller to a change in speed demand. The speed controller includes proportional (Kp) and integral (Ki) feed forward terms, and a differential (Kd) feedback term. The drive holds two sets of these gains and either set may be selected for use by the speed controller with Pr 03.016. If Pr 03.016 = 0, gains Kp1, Ki1 and Kd1 (Pr 00.007 to Pr 00.009) are used, and if Pr 03.016 = 1, gains Kp2, Ki2 and Kd2 (Pr 03.013 to Pr 03.015) are used. Pr 03.016 may be changed when the drive is enabled or disabled. If the load is predominantly a constant inertia and constant torque, the drive can calculate the required Kp and Ki gains to give a required compliance angle or bandwidth dependant on the setting of Pr 03.017.

#### Speed Controller Proportional Gain (Kp), Pr 00.007 {03.010} and Pr 03.013

If the proportional gain has a value and the integral gain is set to zero the controller will only have a proportional term, and there must be a speed error to produce a torque reference. Therefore as the motor load increases there will be a difference between the reference and actual speeds. This effect, called regulation, depends on the level of the proportional gain, the higher the gain the smaller the speed error for a given load. If the proportional gain is too high either the acoustic noise produced by speed feedback quantization becomes unacceptable, or the stability limit is reached.

#### Speed Controller Integral Gain (Ki), Pr 00.008 {03.011} and Pr 03.014

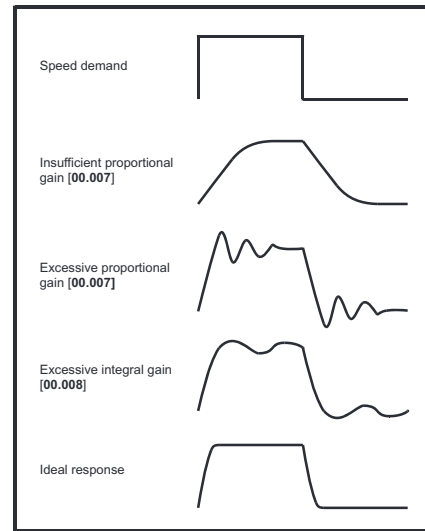
The integral gain is provided to prevent speed regulation. The error is accumulated over a period of time and used to produce the necessary torque demand without any speed error. Increasing the integral gain reduces the time taken for the speed to reach the correct level and increases the stiffness of the system, i.e. it reduces the positional displacement produced by applying a load torque to the motor. Unfortunately increasing the integral gain also reduces the system damping giving overshoot after a transient. For a given integral gain the damping can be improved by increasing the proportional gain. A compromise must be reached where the system response, stiffness and damping are all adequate for the application. For RFC-A Sensorless mode, it is unlikely that the integral gain can be increased much above 0.50.

#### Differential Gain (Kd), Pr 00.009 {0 3.012} and Pr 03.015

The differential gain is provided in the feedback of the speed controller to give additional damping. The differential term is implemented in a way that does not introduce excessive noise normally associated with this type of function. Increasing the differential term reduces the overshoot produced by under-damping, however, for most applications the proportional and integral gains alone are sufficient.

There are six methods of tuning the speed loop gains dependant on the setting of Pr 03.017:

- Pr 03.017 = 0, User set-up.  
This involves the connecting of an oscilloscope to analog output 1 to monitor the speed feedback.  
Give the drive a step change in speed reference and monitor the response of the drive on the oscilloscope.  
The proportional gain (Kp) should be set up initially. The value should be increased up to the point where the speed overshoots and then reduced slightly.  
The integral gain (Ki) should then be increased up to the point where the speed becomes unstable and then reduced slightly.  
It may now be possible to increase the proportional gain to a higher value and the process should be repeated until the system response matches the ideal response as shown.  
The diagram shows the effect of incorrect P and I gain settings as well as the ideal response.
- Pr 03.017 = 1, Bandwidth set-up  
If bandwidth based set-up is required, the drive can calculate Kp and Ki if the following parameters are set up correctly:  
Pr 03.020 - Required bandwidth,  
Pr 03.021 - Required damping factor,  
Pr 03.018 - Motor and load inertia.  
The drive can be made to measure the motor and load inertia by performing a mechanical load measurement autotune (see Autotune Pr 00.040, earlier in this table).
- Pr 03.017 = 2, Compliance angle set-up  
If compliance angle based set-up is required, the drive can calculate Kp and Ki if the following parameters are set up correctly:  
Pr 03.019 - Required compliance angle,  
Pr 03.021 - Required damping factor,  
Pr 03.018 - Motor and load inertia The drive can be made to measure the motor and load inertia by performing a mechanical load measurement autotune (see Autotune Pr 00.040, earlier in this table).
- Pr 03.017 = 3, Kp gains times 16  
If Speed Controller Set-up Method (03.017) = 3 the selected proportional gain used by the drive is multiplied by 16.



#### 5. Pr 03.017 = 4 - 6

If Speed Controller Set-up Method (03.017) is set to a value from 4 to 6 the Speed Controller Proportional Gain Kp1 (03.010) and Speed Controller Integral Gain Ki1 (03.011) are automatically set up to give the bandwidths given in the table below and a damping factor of unity. These settings give low, standard or high performance.

Pr 03.017	Performance	Bandwidth
4	Low	5 Hz
5	Standard	25 Hz
6	High	100 Hz

#### 6. Pr 03.017 = 7

If Speed Controller Set-up Method (03.017) = 7 then Speed Controller Proportional Gain Kp1 (03.010), Speed Controller Integral Gain Ki1 (03.011) and Speed Controller Differential Feedback Gain Kd1 (03.012) are set up to give a closed-loop speed controller response that approximates to a first order system with a transfer function of  $1 / (s\tau + 1)$ , where  $\tau = 1/\omega_{bw}$  and  $\omega_{bw} = 2\pi \times \text{Bandwidth}$  (03.020). In this case the damping factor is meaningless, and Damping Factor (03.021) and Compliance Angle (03.019) have no effect.

## 8.2 Current limits

The default setting for the current limit parameters is:

- 165 % x motor rated torque producing current for open loop mode
- 250 % x motor rated torque producing current for RFC-A and RFC-S modes.

There are three parameters which control the current limits:

- Motoring current limit: power flowing from the drive to the motor
- Regen current limit: power flowing from the motor to the drive
- Symmetrical current limit: current limit for both motoring and regen operation

The lowest of either the motoring and regen current limit, or the symmetrical current limit applies.

The maximum setting of these parameters depends on the values of motor rated current, drive rated current and the power factor.

The drive can be oversized to permit a higher current limit setting to provide higher accelerating torque as required up to a maximum of 1000 %.

## 8.3 Motor thermal protection

A dual time constant thermal model is provided to estimate the motor temperature as a percentage of its maximum allowed temperature.

The motor thermal protection is modelled using losses in the motor. The losses in the motor are calculated as a percentage value, so that under these conditions the *Motor Protection Accumulator* (04.019) would eventually reach 100 %.

Percentage losses = 100 % x [Load related losses + Iron losses]

Where:

$$\text{Load related losses} = (1 - K_{fe}) \times [(I / (K_1 \times I_{Rated}))]^2$$

$$\text{Iron losses} = K_{fe} \times (w / w_{Rated})^{1.6}$$

Where:

$I$  = Current Magnitude (00.012)

$I_{Rated}$  = Rated Current (00.046)

$K_{fe}$  = Rated Iron Losses As Percentage Of Losses (04.039) / 100 %

The *Motor Protection Accumulator* (04.019) is given by:

$$\text{Pr } 04.019 = \text{Percentage Losses} \times [(1 - K_2) (1 - e^{-T/\tau_1}) + K_2 (1 - e^{-T/\tau_2})]$$

Where:

$T$  = Motor Protection Accumulator (04.019)

$K_2$  = Motor Thermal Time Constant 2 Scaling (04.038) / 100 %

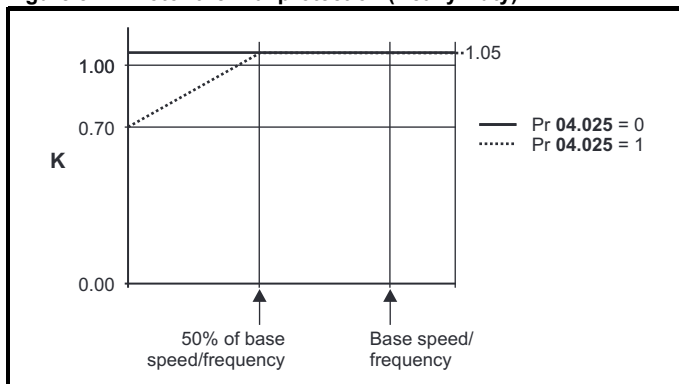
$\tau_1$  = Motor Thermal Time Constant 1 (00.053)

$\tau_2$  = Motor Thermal Time Constant 2 (04.037)

$K_1$  = Varies, see below

If Rated Current (00.046) ≤ Maximum Heavy Duty Current (00.032)

**Figure 8-1 Motor thermal protection (Heavy Duty)**



If Pr **04.025** is 0 the characteristic is for a motor which can operate at rated current over the whole speed range. Induction motors with this type of characteristic normally have forced cooling. If Pr **04.025** is 1 the characteristic is intended for motors where the cooling effect of motor fan reduces with reduced motor speed below 50 % of base speed/ frequency. The maximum value for  $K_1$  is 1.05, so that above the knee of the characteristics the motor can operate continuously up to 105 % current.

When the estimated temperature in Pr **04.019** reaches 100 % the drive takes some action depending on the setting of Pr **04.016**. If Pr **04.016** is 0, the drive trips when Pr **04.019** reaches 100 %. If Pr **04.016** is 1, the current limit is reduced to  $(K - 0.05) \times 100 \%$  when Pr **04.019** reaches 100 %.

The current limit is set back to the user defined level when Pr **04.019** falls below 95 %. The thermal model temperature accumulator accumulates the temperature of the motor while the drive remains powered-up. By default, the accumulator is set to the power down value at power-up. If the rated current defined by Pr **00.046** is altered, the accumulator is reset to zero.

The default setting of the thermal time constant (Pr **00.053**) is 89 s which is equivalent to an overload of 150 % for 100 s from cold.

## 8.4 Switching frequency

The default switching frequency is 8 kHz, however this can be increased up to a maximum of 16 kHz by Pr **00.041** (dependent on drive size). The available switching frequencies are shown below.

**Table 8-1 Available switching frequencies**

Drive size	Model	2 kHz	3 kHz	4 kHz	6 kHz	8 kHz	12 kHz	16 kHz
1	All	✓	✓	✓	✓	✓	✓	✓
2		✓	✓	✓	✓	✓	✓	✓
3		✓	✓	✓	✓	✓	✓	✓

If switching frequency is increased from 8 kHz the following apply:

1. Increased heat loss in the drive, which means that derating to the output current must be applied. See the derating tables for switching frequency and ambient temperature in the *Digitax HD M75X Series Installation and Technical Guide*.
2. Reduced heating of the motor - due to improved output waveform quality.
3. Reduced acoustic noise generated by the motor.
4. Increased sample rate on the speed and current controllers. A trade off must be made between motor heating, drive heating and the demands of the application with respect to the sample time required.

**Table 8-2 Sample rates for various control tasks at each switching frequency**

Level	3, 6, 12 kHz	2, 4, 8, 16 kHz	Open loop	RFC-A RFC-S
Level 1	3 kHz - 167 μs 6 kHz - 83 μs 12 kHz - 83 μs	2 kHz - 250 μs 4 kHz - 125 μs 8 kHz - 62.5 μs 16 kHz - 62.5 μs	Peak limit	Current controllers
Level 2	250 μs	2 kHz - 500 μs 4 kHz - 250 μs 8 kHz - 250 μs 16 kHz - 250 μs	Current limit and ramps	Speed controller and ramps
Level 3	1 ms		Voltage controller	
Level 4	4 ms		Time critical user interface	
Background			Non-time critical user interface	

## 8.5 High speed operation

### 8.5.1 Encoder feedback limits

The maximum encoder frequency should be prevented from exceeding 500 kHz. In RFC-A and RFC-S modes the maximum speed that can be entered in to the speed reference clamps (Pr **00.002** and Pr **00.001**) can be limited by the drive. This is defined by the following (subject to an absolute maximum of 33,000 rpm):

$$\begin{aligned} \text{Maximum speed limit (rpm)} &= \frac{500 \text{ kHz} \times 60}{\text{ELPR}} \\ &= \frac{3.0 \times 10^7}{\text{ELPR}} \end{aligned}$$

Where:

ELPR is the equivalent encoder lines per revolution and is the number of lines that would be produced by a quadrature encoder.

- Quadrature encoder ELPR = number of lines per revolution
- F and D encoder ELPR = number of lines per revolution / 2
- SINCOS encoder ELPR = number of sine waves per revolution

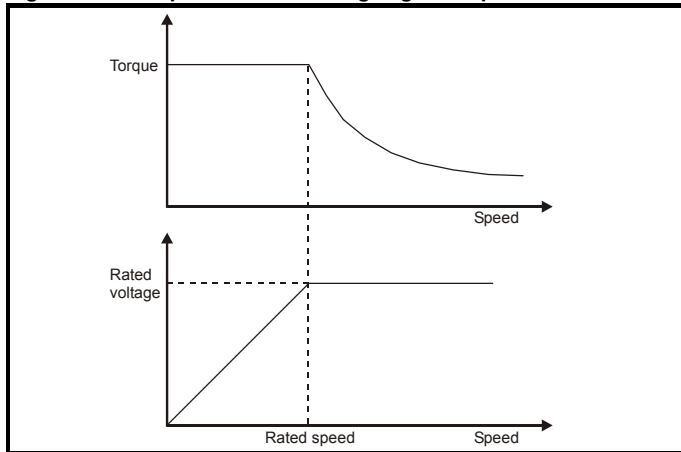
This maximum speed limit is defined by the device selected with the speed feedback selector (Pr **03.026**), and the ELPR set for the position feedback device. In RFC-A mode it is possible to disable this limit via Pr **03.024**, so that the drive can be switched between operation with and without feedback when the speed becomes too high for the feedback device.

### 8.5.2 Field weakening (constant power) operation

(Open loop and RFC-A mode only)

The drive can be used to run an induction machine above synchronous speed into the constant power region. The speed continues to increase and the available shaft torque reduces. The characteristics below show the torque and output voltage characteristics as the speed is increased above the rated value.

**Figure 8-2 Torque and rated voltage against speed**



Care must be taken to ensure the torque available above base speed is sufficient for the application to run satisfactorily. The saturation breakpoint parameters (Pr **05.029**, Pr **05.030**, Pr **05.062** and Pr **05.063**) found during the autotune in RFC-A mode ensure the magnetizing current is reduced in the correct proportion for the specific motor. (In open loop mode the magnetizing current is not actively controlled).

### 8.5.3 Permanent magnet motor high speed operation

High speed servo mode is enabled by setting Pr **05.022** = 1. Care must be taken when using this mode with permanent magnet motor to avoid damaging the drive. The voltage produced by the permanent magnet motor magnets is proportional to speed. For high speed operation the drive must apply currents to the motor to counter-act the flux produced by the magnets. It is possible to operate the motor at very high speeds that would give a very high motor terminal voltage, but this voltage is prevented by the action of the drive.

If however, the drive is disabled (or tripped) when the motor voltages would be higher than the rating of the drive without the currents to counter-act the flux from the magnets, it is possible to damage the drive. If high speed mode is enabled the motor speed must be limited to the levels given in the table below unless an additional hardware protection system is used to limit the voltages applied to the drive output terminals to a safe level.

Drive voltage rating	Maximum motor speed (rpm)	Maximum safe line to line voltage at the motor terminals (V rms)
200	400 x 1000 / (Ke x √2)	400 / √2
400	800 x 1000 / (Ke x √2)	800 / √2
575	955 x 1000 / (Ke x √2)	955 / √2
690	1145 x 1000 / (Ke x √2)	1145 / √2

Ke is the ratio between r.m.s. line to line voltage produced by the motor and the speed in V/1000 rpm. Care must also be taken not to demagnetize the motor. The motor manufacturer should always be consulted before using this mode.

By default, high speed operation is disabled (Pr **05.022** = 0).

It is also possible to enable high speed operation and allow the drive to automatically limit the motor speed to the levels specified in the table and generate an *Overspeed.1* trip if the level is exceeded (Pr **05.022** = -1).

### 8.5.4 Switching frequency

Ideally a minimum ratio of 12:1 should be maintained between the switching frequency and the output frequency. This ensures the number of switchings per cycle is sufficient to ensure the output waveform quality is maintained at a minimum level. If this is not possible, quasi-square switching should be enabled (Pr **05.020** = 1). The output waveform will be quasi square above base speed ensuring a symmetrical output waveform, which results in a better quality output than would otherwise result.

### 8.5.5 Maximum speed / frequency

In all operating modes (Open loop, RFC-A and RFC-S) the maximum output frequency is limited to 550 Hz. However, in RFC-S mode the speed is also limited by the voltage constant (Ke) of the motor. Ke is a specific constant for the servo motor being used. It can normally be found on the motor data sheet in V/k rpm (volts per 1,000 rpm).

### 8.5.6 Quasi-Square wave (open-loop only)

The maximum output voltage level of the drive is normally limited to an equivalent of the drive input voltage minus voltage drops within the drive (the drive will also retain a few percent of the voltage in order to maintain current control). If the motor rated voltage is set at the same level as the supply voltage, some pulse deletion will occur as the drive output voltage approaches the rated voltage level. If Pr **05.020** (Quasi-square wave enable) is set to 1 the modulator will allow over modulation, so that as the output frequency increases beyond the rated frequency the voltage continues to increase above the rated voltage. The modulation depth will increase beyond unity; first producing trapezoidal and then quasi-square waveforms.

This can be used for example:

- To obtain high output frequencies with a low switching frequency which would not be possible with space vector modulation limited to unity modulation depth,

or

- In order to maintain a higher output voltage with a low supply voltage.

The disadvantage is that the machine current will be distorted as the modulation depth increases above unity, and will contain a significant amount of low order odd harmonics of the fundamental output frequency. The additional low order harmonics cause increased losses and heating in the motor.

## 9 Drive communication

### 9.1 Ethernet communication

This section describes the adaptation of the Ethernet interface offered on the Digitax HD M750. The portable software class which implements this protocol is also defined.

#### 9.1.1 Features

The following list gives an overview of the functionality available:

- Dual RJ45 connectivity with support for shielded twisted pair.
- 100 Mbs Ethernet with auto-negotiation.
- Full and half duplex operation with auto-negotiation.
- Auto crossover detection.
- TCP/IP.
- Modbus TCP/IP.
- EtherNet/IP or Profinet IO.
- Switch or Gateway mode.
- VLAN tagging.
- SyPTPro.
- Connect.
- Machine Control Studio.
- Static IP configuration or DHCP client.
- Non-cyclic data transfer with user program.
- Up to 3 transmit and 3 receive cyclic links (easy mode).
- IEEE 1588 Precision Time Protocol synchronization.
- RTMoE (Real Time Motion over Ethernet).

#### 9.1.2 Backup/auxiliary supply

Some drives provide a method of powering up the control circuits (and therefore any option module installed) if the AC supply is removed, this allows Ethernet communication to continue operating when the main AC supply is switched off.

#### 9.1.3 Network design considerations

Ethernet is an open system allowing many different vendors to design and supply equipment. When designing an industrial network you must carefully consider the topology and data traffic on the network to avoid potential problems. To avoid bandwidth issues it is recommended that the control network is logically separate from any other network. Where possible a physically separate network should be used. If this is not possible, the use of managed network devices should be considered to prevent unnecessary traffic such as broadcasts reaching the control network.

#### NOTE

The use of un-switched hubs is not supported.

#### 9.1.4 Addressing

The addressing system used on Ethernet uses two essential numbers for making connection, these are the IP address and the subnet mask.

The address allows a specific device to be located and the subnet mask defines how many bits represent the subnet part of the address and how many bits represent the node address (see section 9.1.7 *Generating the complete address* on page 94). Generally devices on different subnets can only communicate by using a gateway (typically a router or firewall).

#### 9.1.5 Where do IP addresses come from

Every address on a network must be unique. If you do not connect your network to any other networks the assignment of IP addresses is not critical (although using a standard system is recommended), as you have full control of the addresses used. The issue of addressing becomes important when connecting multiple networks together or connecting to the Internet where there is a strong possibility of duplication of addresses if a scheme is not followed.

#### 9.1.6 Addressing etiquette

The following list details some points that should be considered when selecting addresses:

- **Reserve address space:** Ensure you have enough reserve address space on your chosen addressing scheme to allow for future expansion.
- **Uniqueness:** Ensure your addresses are unique, every device on a subnet must have a unique address.
- **Avoid reserved addresses:** For example the address 127.0.0.1 is reserved as the loop back address.
- **Broadcast and system addresses:** The highest and lowest host address on a subnet are reserved addresses.
- **Use a system:** Have a scheme for assigning your addresses, for example typically servers may have a low IP address and routers a high IP address. It is not necessary to allocate consecutive IP addresses so it is possible to reserve ranges for specific uses such as servers, work stations or routers.

#### 9.1.7 Generating the complete address

A complete IP address consists of an IP address and a subnet mask, these two numbers are required to allow communication on Ethernet using TCP/IP.

##### The IP address

The IP address is made up from four 8 bit decimal numbers (octets) and is written as follows:

w.x.y.z for example 192.168.0.1

##### The subnet mask

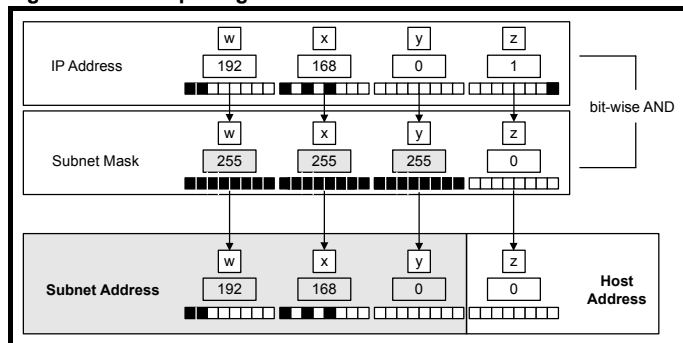
The subnet mask defines what part of the address constitutes the subnet within the IP address and what part of the address constitutes the host address. The subnet mask is bit-wise ANDed with the address to give the subnet to which the host belongs. A typical subnet mask would be 255.255.255.0, this may alternatively be written as '/24' as in the example below, showing an IP address of 192.168.0.1 with a subnet mask of 255.255.255.0. This alternative notation indicates the number of bits representing the subnet part of the address, starting from the most significant bit.

Alternative subnet mask notation: 192.168.0.1 /24

##### Completing the address

To determine which part of the address constitutes the network address and which part constitutes the node address, the IP address is bit-wise ANDed with the subnet mask. Figure 9-1 shows how the IP address and subnet mask are used to determine the subnet address and the host address.

Figure 9-1 Completing the address



#### 9.1.8 DHCP considerations

##### Using fixed IP addressing

Using fixed IP addresses (manually configured) means that if a module fails, the IP address can be restored to a replacement module without the need to reconfigure the DHCP server. Using fixed addresses also prevents the DHCP server from changing the address. When using fixed IP addresses, it is vital that the IP address is reserved on the DHCP server to prevent duplicate addressing.

**NOTE**

If using manual IP address configuration please note that the IP address subnet mask and the default gateway must also be set manually.

**NOTE**

In Profinet mode, Pr **3.02.005** (DHCP Enable) will be forced off on initialization.

### 9.1.9 Basic principles of routing

Routing is required to get TCP/IP packets from one subnet to another. In an IP network, nodes from one subnet cannot communicate directly with nodes on a different subnet. To allow nodes to communicate, a router (or similar device) is required to allow the two subnets to exchange data.

This means that any node wishing to communicate with a node that is not on its own subnet, must know the address of a router that is on its own subnet. This is sometimes called a gateway or default gateway.

## 9.2 CT Modbus TCP/IP specification

### Modbus TCP/IP

Modbus TCP/IP is one of the most widely supported industrial Ethernet based protocols offering the functionality and simplicity of the Modbus protocol, with the flexibility of Ethernet. Table 9-1 shows the supported Modbus function codes.

Modbus TCP/IP uses the standard Modbus RTU Protocol Data Unit (PDU) but without the CRC bytes and encapsulates it within a Modbus TCP/IP Application Data Unit (ADU) for transmission. This means that the Modbus PDU is the same for both standard (RTU) and Ethernet based transmission.

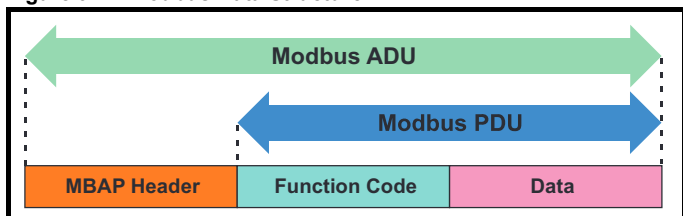
**Table 9-1 Supported Modbus function codes**

Code	Description
3	Read multiple 16 bit registers.
6	Write single 16 bit register.
16	Write multiple 16 bit registers.
23	Read and write multiple 16 bit registers.

### 9.2.1 Data structure

Communication between devices is based upon Modbus Application Data Units (ADUs), the ADU consists of 2 parts, the Modbus Application Protocol (MBAP) header and the Modbus Protocol Data Unit (PDU).

**Figure 9-2 Modbus Data Structure**



**Table 9-2 MBAP Header**

Field	Length (Bytes)	Description
Transaction Identifier	2	Uniquely identifies the transaction (0 to 65535)
Protocol Identifier	2	Identifies the protocol (0 = Modbus)
Length	2	Number of following bytes in the message
Unit Identifier	1	Uniquely identifies the destination node (0 to 255)

The unit identifier within the MBAP header is used to identify whether the destination node is the host drive or an option module.

**Table 9-3 MBAP Unit Identifier**

Unit Identifier	Destination
0 or 255	Drive
1	Slot 1
2	Slot 2
3	Slot 3 (Factory Fit Ethernet)
254	Self

### 9.2.2 Data access

Data access using Modbus TCP/IP takes the form of a request for data by the master, followed by a response from the slave indicating success or failure. If no response is received this indicates that the message has not been received or the message is invalid or the node is unable to reply.

Each drive or option module parameter is internally mapped to a single 16-bit Modbus register, all Modbus function codes access 16-bit registers only. To access a 32-bit parameter, two contiguous Modbus registers must be specified in the request and the 32-bit data access scheme must be used.

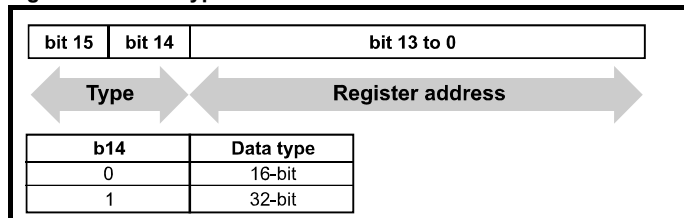
### 9.2.3 32-bit data access

Standard Modbus registers are 16 bits in size and reference a single drive/option module parameter. To access a 32-bit data value the multiple read/write services must be used to transfer a contiguous array of 16-bit registers. To instruct the client to select either 16-bit or 32-bit access bit 14 of the register address is used.

**NOTE**

Bit b15 of the register address is reserved for future use.

**Figure 9-3 Data type selection**



If 32-bit data type is selected then this effectively adds 16384 (0x4000) to the start register address.

e.g. For drive parameter Pr **01.021** in standard addressing mode, the start register value is 16384 + 120 = 16504 (0x4078)

### 9.2.4 Supported Modbus function codes

The following table details the supported Modbus function codes.

**Table 9-4 Supported Modbus function codes**

Function Code		Description
Decimal	Hex (0x)	
3	03	Read multiple 16-bit registers
6	06	Write single 16-bit register
16	10	Write multiple 16-bit registers
23	17	Read and write multiple 16-bit registers

## 9.2.5 Register addressing

The Modbus register address is 16 bits in size, of which the upper two bits are used for data type selection leaving 14 bits to represent the parameter address, taking into account the slave increments the address value by 1, this results in a theoretical maximum parameter address of 163.84 (limited to 162.99 in software) when the default standard addressing mode (see Modbus Register Addressing Mode (3.15.013)) is used.

To access a parameter number above 99 then the modified addressing mode must be used (see Modbus Register Addressing Mode (3.15.013)), this will allow access to parameter numbers up to 255 but also limit the maximum menu number to 63.

### NOTE

A reset is not required to activate the change, the addressing mode is effectively made active immediately on changing.

The Modbus slave device increments the register address by 1 before processing the command, this effectively prevents access to parameter Pr 00.000 in the drive or option module.

Table 9-5 shows how the start register address is calculated for both addressing modes.

**Table 9-5 Start register addressing**

CT Parameter	Addressing mode	Protocol register			
s.mm.ppp	Standard	mm * 100 + ppp - 1			
	Modified	mm * 256 + ppp - 1			
<b>Examples</b>					
		16-bit		32-bit	
		Decimal	Hex (0x)	Decimal	Hex (0x)
0.01.021	Standard	120	00 78	16504	40 78
	Modified	276	01 14	16660	41 14
0.01.000	Standard	99	00 63	16483	40 63
	Modified	255	00 FF	16639	40 FF
S.70.001	Standard	7000	1B 58	23384	5B 58
	Modified	N/A	N/A	N/A	N/A
0.03.161	Standard	N/A	N/A	N/A	N/A
	Modified	928	03 A0	17312	43 A0

## 9.2.6 FC03 - Read multiple registers

This function code allows a contiguous array of registers to be read. The maximum number of registers that can be read is 120, this allows up to 120 16-bit parameters or 60 32-bit parameters to be read in a single transaction. If this is exceeded the server will issue an exception response code 2.

### Master request data

Byte	Description
7	Function code 0x03
8	Start register address (MSB)
9	Start register address (LSB)
10	Number of 16-bit registers (MSB)
11	Number of 16-bit registers (LSB)

### Slave response data

Byte	Description
7	Function code 0x03
8	Length of data in read block (Bytes)
9	Register data (MSB)
10	Register data (LSB)

The normal response includes the function code, number of data bytes in the read block followed by the register data (unless an exception occurs).

If 32-bit parameter addressing is used, then for each parameter read:

- Two 16-bit registers must be used in the request
- The register data in the response will contain 4 bytes of data

### Example

To read drive parameters 0.20.021 to 0.20.023 (transaction ID = 42) with 32-bit data access and standard addressing:

### Master request data

Byte	Hex value	Description
0-1	00 2A	Transaction ID (42)
2-3	00 00	Protocol ID (0=TCP/IP)
4-5	00 06	Length (Bytes=6)
6	FF	Unit identifier (FF= Drive)
7	03	Function code (3)
8-9	47 E4	Start register (20.20)
10-11	00 06	Number of registers (6)

### Slave response data

Byte	Hex value	Description
0-1	00 2A	Transaction ID (42)
2-3	00 00	Protocol ID (0=TCP/IP)
4-5	00 0F	Length (Bytes=15)
6	FF	Unit identifier (FF= Drive)
7	03	Function code (3)
8	0C	Data length (Bytes=12)
9-12	?*	Pr 0.20.021 data
13-16	?*	Pr 0.20.022 data
17-20	?*	Pr 0.20.023 data

\* Value dependent on data read

## 9.2.7 FC06 - Write single register

This function code writes a single 16-bit value to a register. The normal response is an echo of the request (unless an exception occurs) returned after the parameter has been written.

The register address can be a 32-bit parameter address but only the lower 16 bits of the value will be written.

### Master request data

Byte	Description
7	Function code 0x06
8	Start register address (MSB)
9	Start register address (LSB)
10	Register data (MSB)
11	Register data (LSB)

### Slave response data

Byte	Description
7	Function code 0x06
8	Start register address (MSB)
9	Start register address (LSB)
10	Register data (MSB)
11	Register data (LSB)

### Example

To write the value 12345 to drive parameter 0.20.001 (transaction ID = 42) using standard addressing:

### Master request data

Byte	Hex value	Description
0-1	00 2A	Transaction ID (42)
2-3	00 00	Protocol ID (0=TCP/IP)
4-5	00 06	Length (Bytes=6)
6	FF	Unit identifier (FF= Drive)
7	06	Function code (06)
8-9	07 D0	Start register (20.000)
10-11	30 39	Register data (12345)

### Slave response data

Byte	Hex value	Description
0-1	00 2A	Transaction ID (42)
2-3	00 00	Protocol ID (0=TCP/IP)
4-5	00 06	Length (Bytes=6)
6	FF	Unit identifier (FF= Drive)
7	06	Function code (6)
8-9	07 D0	Start register (20.000)
10-11	30 39	Register data (12345)

### 9.2.8 FC16 - Write multiple registers

This function code allows a contiguous series of registers to be written.

The maximum number of registers that can be written is 120, this allows up to 120 16-bit parameters or 60 32-bit parameters to be read in a single transaction. If this is exceeded the server will issue an exception response code 2. The normal response includes the function code, start register address and number of 16-bit registers written (unless an exception occurs), returned after the parameters have been written.

If 32-bit parameter addressing is used, then for each parameter written:

- Two 16-bit registers must be used in the request.
- Four bytes must be specified in the request.
- The number of registers written in the response will be twice the number of parameters written.

#### Master request data

Byte	Description
7	Function code 0x10
8	Start register address (MSB)
9	Start register address (LSB)
10	Number of 16-bit registers (MSB)
11	Number of 16-bit registers (LSB)
12	Length of register data to write (Bytes)
13	Register data (MSB)
14	Register data (LSB)

#### Slave response data

Byte	Description
7	Function code 0x10
8	Start register address (MSB)
9	Start register address (LSB)
10	Number of 16-bit registers written (MSB)
11	Number of 16-bit registers written (LSB)

#### Example

To write the value 12345 to drive parameters **0.20.021** through **0.20.023** (Transaction ID=42) using standard 32-bit addressing:

#### Master request data

Byte	Hex value	Description
0-1	00 2A	Transaction ID (42)
2-3	00 00	Protocol ID (0=TCP/IP)
4-5	00 13	Length (Bytes=19)
6	FF	Unit identifier (FF= Drive)
7	10	Function code (16)
8-9	47 E4	Start register ( <b>20.020</b> )
10-11	00 06	Number of registers (6)
12	0C	Register data length (Bytes)
13-16	00 00 30 39	Register data 0
17-20	00 00 30 39	Register data 1
21-24	00 00 30 39	Register data 2

#### Slave response data

Byte	Hex value	Description
0-1	00 2A	Transaction ID (42)
2-3	00 00	Protocol ID (0=TCP/IP)
4-5	00 06	Length (Bytes=6)
6	FF	Unit identifier (FF= Drive)
7	10	Function code (16)
8-9	47 E4	Start register ( <b>20.020</b> )
10-11	00 06	Registers written (6)

### 9.2.9 FC23 - Read/Write multiple registers

This function code allows a contiguous series of registers to be written and another contiguous series of registers to be read. The maximum number of registers that can be read is 120 and similarly the maximum number of registers that can be written is 120, this allows up to 120 16-bit parameters or 60 32-bit parameters to be read and / or written in a single transaction. If this is exceeded the server will issue an exception response code 2

#### Master request data

Byte	Description
7	Function code 0x17
8	Start read register address (MSB)
9	Start read register address (LSB)
10	Number of registers to read (MSB)
11	Number of registers to read (LSB)
12	Start write register address (MSB)
13	Start write register address (LSB)
14	Number of registers to write (MSB)
15	Number of registers to write (LSB)
16	Length of register data to write (Bytes)
17	Register data 0 (MSB)
18	Register data 0 (LSB)

#### Slave response data

Byte	Description
7	Function code 0x17
8	Length of data in read block (Bytes)
9	Register data (MSB)
10	Register data (LSB)

The normal response includes the function code, number of data bytes in the read block followed by the register data (unless an exception occurs).

If 32-bit parameter addressing is used:

- For each parameter read or written, two 16-bit registers must be used in the request.
- For each parameter written, four bytes must be specified in the request.
- For each parameter read, four bytes of data will be used in the response.

### Example

To write the value 12345 to drive parameters **0.20.021** through **0.20.023** and read the values of parameters **0.20.024** through **0.20.026** (Transaction ID=42) using standard addressing:

#### Master request data

Byte	Hex value	Description
0-1	00 2A	Transaction ID (42)
2-3	00 00	Protocol ID (0=TCP/IP)
4-5	00 17	Length (Bytes=6)
6	FF	Unit identifier (FF= Drive)
7	17	Function code (23)
8-9	47 E7	Start read register ( <b>0.20.023</b> )
10-11	00 06	Number of read registers (6)
12-13	47 E4	Start write register ( <b>0.20.020</b> )
14-15	00 06	Number of write registers (6)
16	0C	Length of register data to write (Bytes=12)
17-20	00 00 30 39	Register data 0 (12345)
21-24	00 00 30 39	Register data 1 (12345)
25-28	00 00 30 39	Register data 2 (12345)

#### Slave response data

Byte	Hex value	Description
0-1	00 2A	Transaction ID (42)
2-3	00 00	Protocol ID (0=TCP/IP)
4-5	00 0F	Length (Bytes=15)
6	FF	Unit identifier (FF= Drive)
7	17	Function code (23)
8	0C	Length of data (Bytes=12)
9-12	?? ?? ?? ??*	Register data 0 (Pr <b>0.20.024</b> )
13-16	?? ?? ?? ??*	Register data 1 (Pr <b>0.20.025</b> )
17-20	?? ?? ?? ??*	Register data 2 (Pr <b>0.20.026</b> )

\* Value dependent on data read

### 9.2.10 Modbus Exception Response Message

If the master request is rejected then an exception response message will be returned.

**Table 9-6 Exception Response Message**

Byte	Hex value	Description
0-1	?? ??*	Transaction ID (defined by Modbus Master)
2-3	00 00	Protocol ID
4-5	00 03	Number of data bytes to follow
6	??*	Unit identifier
7	??*	Function code (request FC with bit b7 set to 1)
8	??*	Exception code 01 = Function code not supported 02 = Invalid register address

\* Value dependent on data read

The master request function code will be returned but with bit b7 set (e.g. function code 0x03 will be returned as 0x83).

## 9.3 RTMoE (Real Time Motion over Ethernet)

This is a communication protocol developed to provide Ethernet synchronisation and data transfer between Control Techniques drives.

#### RTMoE provides:

Drive synchronisation

- Drive synchronisation using the Precision Time Protocol (PTP) otherwise known as IEEE1588 V2. Each PTP device has a tuneable clock running. Following an arbitration process the devices select a master and tune their clocks until they are synchronized to that master. This process may take several seconds to complete.

Data transfer

- Cyclic data (synchronous and non-synchronous) is sent using the User Datagram Protocol (UDP)
- Non-cyclic data is sent using the Transmission Control Protocol (TCP)
- Cycle time down to 250 µs (Using Machine Control Studio)
- Jitter less than 1 µs

RTMoE can be configured in two ways:

- Via Machine Control Studio using the Advanced link editor or
- Via parameters using the Easy Mode menus (10 and 11)

The full capabilities of RTMoE are available only when using Machine Control Studio.

Table 9-7 shows the comparison between Easy Mode and Machine Control Studio support levels.

**Table 9-7 RTMoE Support levels**

Capability	Support Level	
	Easy Mode	Machine Control Studio <sup>(1) (3)</sup>
Non-cyclic communication	No	Yes
Total number of transmit cyclic links	3	11
Total number of receive cyclic links	3	11
Max transmit synchronous links	1	1
Max receive synchronous links	1	1
Max length of non-synchronous link	10 x 32-bit	10 x 32-bit <sup>(2)</sup>
Max length of synchronous link	3 x 32-bit	3 x 32-bit
Minimum transmission period (non-synchronised)	1 ms	1 ms
Maximum transmission period (non-synchronised)	100 ms	100 ms <sup>(3)</sup>
Minimum transmission period (Synchronised)	1 ms	250 µs
Maximum transmission period (Synchronised)	8 ms	8 ms
Synchronised with onboard program	Yes (when cycle time = 4 ms)	Yes (when cycle time = 4 ms)
Max parameter accesses per second	6000	6000
Max messages per second ( <b>S.02.004</b> )	8000	8000

(1) MCI2x0 firmware version V01.08.04.06 and later.

(2) Maximum number of parameter in a non-synchronous link between two MCI210 modules (V01.08.04.06 and later) is 20.

(3) Currently the Ethernet interface only supports cyclic links using Easy Mode (Menu 10), cyclic links using Machine Control Studio will be available in a future release of the Ethernet interface firmware.

#### NOTE

The number of cyclic links is limited to a maximum of 2 when accessing the option module internal parameters (e.g. the PLC register menus 7x).

### 9.3.1 RTMoE Message rate capability

When designing a network, the message loading for each device should be checked to ensure the number of messages do not exceed the maximum recommended value.

Consider the following example where a Digitax HD M750 is communicating with three other devices over Ethernet using Modbus TCP/IP (10 parameters read every 100 ms), EtherNet/IP (5 parameters read every 10 ms and 5 parameters written every 10 ms) and RTMoE (2 parameters written every 500 μs).

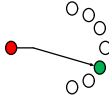
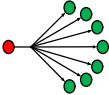
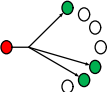
Protocol	Number of Parameters	Rate	Parameters accessed / second	Message rate / second
Modbus TCP/IP	10 x read	100 ms	100	10
EtherNet/IP	5 x read	10 ms	500	100
	5 x write	10 ms	500	100
RTMoE	2 x write	500 μs	4000	2000
Total			5100	2210
Maximum supported			6000	8000
Within capability?			✓	✓

### 9.3.2 RTMoE Message type

From the system design, it should be known how many drives will be used and what data needs to be sent where. There are two fundamental ways of sharing data:

- Cyclic data – use cyclic links for important information relating to the dynamic behavior of the machine (e.g. control word, speed reference, etc.)
- Non-cyclic data – used for non time-critical information (e.g. drive setup data) A user program must be used to control the transfer of non-cyclic messages. (see *Non cyclic enable* (S.02.035) and *Non cyclic base parameter* (S.02.036))

Each cyclic message can be one of three types:

- 1 Unicast – used if data needs to go from one device to another 
- 2 Broadcast – used if data needs to go from one device to all other devices 
- 3 Multicast – used if data needs to go from one device to a subset of the other devices 

By choosing the most appropriate transmission type an efficient and reliable network can be designed.

For example:

- Three drives must use an ELS (Electronic Line Shaft) to follow a Smart Drive. In this case a **multicast** message should be used to transmit the reference position from the Smart Drive.
- Three drives need to return general status information to the Smart Drive. In this case, each drive should send a **unicast** message to the Smart Drive.
- The Smart Drive needs to command all other drives to stop/start. The Smart Drive should use a broadcast message to transmit the command to all the other drives.

#### NOTE

Broadcast messages should be used with care, bottlenecks in the network can be easily created by using broadcast messages, this will reduce the performance of the network and, in extreme situations, seriously impair the system operation.

### 9.3.3 Checking for bottlenecks

There are three main reasons why a bottleneck occurs:

1. A drive is receiving more Ethernet messages than it can handle (8000 frames per second).
2. A drive is being asked to access more parameters than it can handle (6000 parameters per second).
3. A segment of the network has reached it's bandwidth limit.

For a full duplex 100Mbit/sec Ethernet network, assuming all Ethernet messages are the maximum 1500 bytes in length, the bandwidth is 8000 frames/sec in each direction.

#### NOTE

- It is unrealistic to assume that all messages will be full frames.
- In reality the maximum number of frames/sec will be higher.
- A more detailed frame analysis may be performed if necessary but the values stated can be used to quickly determine whether bottlenecks could be a problem.

### 9.3.4 RTMoE Message synchronization

Cyclic messages can be synchronized or non-synchronized.

Only one synchronized cyclic link in each direction (one transmit and one receive) is possible so these should only be used for high precision applications where the motion of multiple drives must be closely coupled (e.g. printing applications). All other messages should be sent using a non-synchronized cyclic link.

Synchronized cyclic data links utilise the IEEE1588 clock time distributed across the network. The IEEE1588 clock can synchronize the drive's control loops to within a 1 μs accuracy, Pr 0.11.002 *Option Synchronisation Active* displays the active option slot providing synchronization. With synchronized control loops the Ethernet interface can be used to transfer drive parameters containing motion information, including those from the AMC.

With normal Ethernet there are a number of variables that can impact upon the performance of the network. These include:

- Delays through switches - Ethernet is a switched network and messages are typically copied completely into a switch before being forwarded on. *This is fundamental to modern Ethernet and cannot be influenced by system design.*
- Message length – the longer a message, the longer it will take to transmit and copy into a switch before forwarding it on. For a synchronous cyclic link frame this delay is 12 μs, for a full Ethernet frame it is 120 μs.  
Message length can be controlled, but to maximise compatibility with other Ethernet traffic, it is sensible to allow for full frame Ethernet messages where possible.
- Length of daisy chain - A daisy chain with Ethernet is really a chain of three port switches.  
This can be controlled through physical network design e.g. using a tree structure to limit the length of daisy chains.

The above delays (Latency) are managed in software, in conjunction with PTP, to ensure that all device use synchronous data at the same time, but the length of the daisy chain must be controlled by careful network design.

### 9.3.5 General guidelines for synchronous cyclic data

The following guidelines provide a simple way of specifying a network supporting synchronous cyclic data that offers accurate synchronization and guaranteed determinism, whilst maintaining compatibility with standard Ethernet traffic.

- Limit daisy chains to 10 drives.
- Where more than 10 drives are used, create a tree structure using a switch.
- Any Ethernet switches used must support IEEE1588 V2.
- Segregate the network using VLANs and gateways.

Assign one device to be the synchronization master for each segregated network.

### 9.3.6 Segregating the network

If synchronous cyclic links are used, for best reliability it is sensible to segregate the network. This means:

- Assign one (or more) drive(s) to be a gateway, which ensures messages entering the segregated section are stripped of any existing prioritisation information. (See *Gateway Mode (3.02.025)*)
- Ensure that **VLAN** (Virtual Local Area Network) is enabled on all devices so that synchronous data can be prioritized as it is passed between switches. (See *VLAN Enable (3.02.030)*)
- Use multiple Master Clock Domains. (See *Master Clock Domain (3.11.002)*)

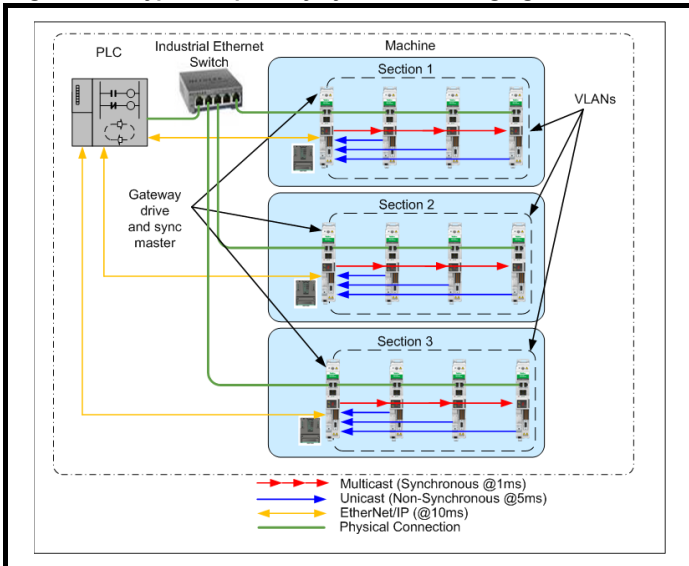
### 9.3.7 Synchronization master

If a synchronous cyclic link is used then one device must be a synchronous master, if this is an existing 3<sup>rd</sup> party device then, to minimize the initialization time, all other devices/drives on the network should not be allowed to become the synchronous master. To disable the drive from becoming the synchronous master then set the value in *Preferred Sync Master (3.11.001)* to 0, this ensures the drive does not become the synchronous master.

If there is no existing synchronous master then a suitable drive should be chosen (see *Preferred Sync Master (3.11.001)*), in choosing which drive to be the synchronous master, the physical position of the drives and network layout should be considered so as to minimize the number of switches each message has to pass through.

A typical segregated network using VLANs and gateways consisting of three separate sections of a machine controlled by one master PLC is shown in the following diagram.

Figure 9-4 Typical separately synchronized segregated network



#### NOTE

Configuring a single drive to act as both gateway and synchronization master will increase the message loading on that drive, in some situations this may result in a reduction of the network performance. In these situations, separate drives should be used for the gateway and synchronization master.

#### NOTE

For the gateway mode to operate correctly, the standard Ethernet network must be connected to port 1 on the drive and the real-time Ethernet to port 2 as shown in Figure 9-4.

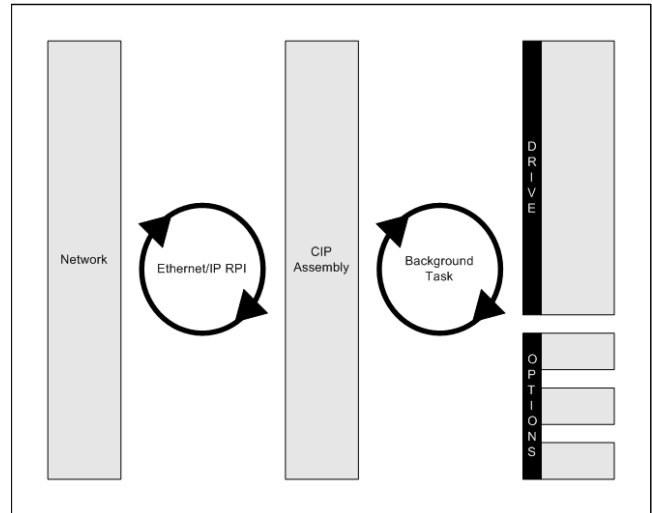
### 9.3.8 VLANs

To guarantee the timing of synchronous links VLANs must be enabled using *VLAN Enable (3.02.030)*. VLANs include a priority field that is applied to all messages. This field is used to apply a higher priority to synchronous cyclic data than other non-deterministic traffic.

### 9.3.9 Parameter Update Rate

Parameters are exchanged over the network. The value exchanged over the network must be exchanged with the drive or option parameter. The rate of data exchange differs for synchronous and non-synchronous cyclic links as well as for drive and option destinations.

The diagram below depicts the update cycles used within the Ethernet interface. Cyclic link mappings being exchanged with the drive will be updated at the background task rate. This rate (*Background cycles per second (3.09.008)*) varies with the load on the Ethernet interface; EtherNet/IP data exchange also takes place in the background task.



## 9.4 EtherNet/IP specification

The Ethernet interface supports the EtherNet/IP protocol and conforms to the EtherNet/IP adaptation of the Common Industrial Protocol (CIP) Specification. This is the same upper-layer protocol and object model as used in DeviceNet.

The Ethernet interface module will operate as a slave device and the following functionality is supported:

- Variable length input assembly object (instance 100) with consistency for up to 32 parameters
- Variable length output assembly object (instance 101) with consistency for up to 32 parameters
- User selectable RPI timeout action
- Identity object (class 0x01)
- Motor data object (class 0x28)
- Control supervisor object (class 0x29)
- AC/DC Drive object (class 0x2A)
- Control Techniques objects (classes 0x64 to 0x69)
- Explicit (non-cyclic) access to parameters

### 9.4.1 Requested Packet Interval (RPI) timeout

This timeout is defined by the EtherNet/IP protocol and is configured in the PLC master. If enabled, the Ethernet interface will monitor the data traffic once the cyclic data has been established, and if data is not received within the specified time, it will perform the requested action as defined by Pr **3.20.011 RPI timeout action**. This indicates that the interface has detected that the cyclic data communication has been interrupted.

#### NOTE

The RPI timeout action will only occur on a loss of cyclic data message, i.e. after cyclic data has been established and subsequently lost. No action will be taken if no cyclic data has been detected.

### 9.4.2 Read consistency

Under normal conditions, cyclic data is sampled and transmitted at the Requested Packet Interval (RPI). However, if an option module was in the process of modifying the mapped parameters while these parameters were being sampled, then the data transmitted across the network may not be consistent across the entire assembly object. If read consistency is enabled (**3.20.026 In Consistency Enable**) and a trigger parameter specified in *In Consistency Trigger Param* (**3.20.027**) then data will only be sampled and transmitted when the trigger parameter *In Consistency Trigger Param* (**3.20.027**) contains a non-zero value. This trigger parameter will then be set to zero after the data has been sampled.

It is therefore possible, by controlling the trigger parameters, that a user program in the drive or option module can ensure that the values in the cyclic data parameters are not sampled until all values are updated.

Whether consistency is enabled or not, data will always be consistent for an individual parameter, i.e. all 4 bytes of a 32-bit value will be consistent.

### 9.4.3 Write consistency

Under normal conditions, cyclic data is sampled and written at the Requested Packet Interval (RPI). However, if an option module was in the process of reading the mapped parameters while these parameters were being written, then the data obtained may not be consistent across the entire assembly object. If write consistency is enabled (*Out Consistency Enable* (**3.20.028**)) and a trigger parameter specified in *Out Consistency Trigger Param* (**3.20.029**) then new data will only be written to the drive (or option module) when the trigger parameter *Out Consistency Trigger Param* (**3.20.029**) contains a value of zero. This trigger parameter will then be set to one after the data has been written.

It is therefore possible, by controlling the trigger parameters, that a user program in the drive or option module can ensure that the values in the cyclic data parameters are not sampled until all values are updated.

Whether consistency is enabled or not, data will always be consistent for an individual parameter, i.e. all 4 bytes of a 32-bit value will be consistent.

#### Example

In this example, Pr **0.18.031** is set as the input trigger and Pr **0.18.032** is set as the output trigger. The EtherNet/IP master is configured to check the values of Pr **0.20.011** and Pr **0.20.012** are equal and write the same value to Pr **0.20.021**. The SI-Applications Compact module is configured to generate a ramp value between -32768 and 32767 to write to Pr **0.20.011** and Pr **0.20.012** when the value of Pr **0.20.021** is equal to the ramp value.

With the input and output consistency enabled, parameters Pr **0.20.011** and Pr **0.20.012** will be sampled and transmitted to the EtherNet/IP master when the input trigger parameter Pr **0.18.031** is a non-zero value, Pr **0.20.021** will be written to when the output trigger parameter Pr **0.18.032** is a value of zero.

The parameter changes required are:

<b>3.20.020</b> <i>Input assembly object size</i>	= 8 (bytes)
<b>3.20.021</b> <i>Output assembly object size</i>	= 4 (bytes)
<b>3.20.026</b> <i>In Consistency Enable</i>	= On

<b>3.20.027</b> <i>In Consistency Trigger Param</i>	= 0.18.031
<b>3.20.028</b> <i>Out Consistency Enable</i>	= On
<b>3.20.029</b> <i>Out Consistency Trigger Param</i>	= 0.18.032
<b>3.21.001</b> <i>Input mapping parameter 1</i>	= 0.20.011
<b>3.21.002</b> <i>Input mapping parameter 2</i>	= 0.20.012
<b>3.22.001</b> <i>Output mapping parameter 1</i>	= 0.20.021

The user program in the SI-Applications Compact module may be written as follows (some changes may be necessary to account for bus cycle times and parameter update rates):

```
Initial{
    // Initialise variables
    NewValue% = 0
    #86.03 = 0 // Set digital output0 off
    #86.04 = 0 // Set digital output1 off
    #20.011 = 0 // Set input parameter 1 to 0
    #20.012 = 0 // Set input parameter 2 to 0
    #20.021 = 0 // Set output parameter 1 to 0
    REINIT // Initialise configuration
} //Initial

Background{
top:

IF #18.32 = 1 THEN
    // Output trigger set
    // Check first sum value against NewValue
    IF #20.021 = NewValue% THEN
        // OK increment values by 1
        NewValue% = NewValue% + 1
        IF NewValue% > 32767 THEN NewValue = -32768
        #20.011 = NewValue%
        #20.012 = NewValue%

        // Set input trigger – Read input parameters and
        // transmit to master
        #18.031 = 1

        // Delay for PLC to get inputs - depends on cycle
        // time and parameter access time
        DO WHILE #18.031 = 1
            // Dummy command
            NewValue% = NewValue%
        LOOP

        // Reset output trigger
        #18.032 = 0

        // Delay for outputs to be written - depends on
        // parameter access time
        DO WHILE #18.032 = 0
            // Dummy command
            NewValue% = NewValue%
        LOOP

    ELSE

        // ERROR - set DOP0 ON
        #86.03 = 1
    ENDIF
ENDIF

goto top: // main background loop
} //Background
```

### 9.4.4 Non-cyclic (explicit) data transfer

Non-cyclic or explicit messaging is used to read and write parameters non-cyclically by means of assembly objects. All of the AC Drives profile attributes can be accessed using explicit messaging.

The *Control Techniques* objects provide access to all drive and slot parameters using the following format.

Object	CT Group	CT This Slot	CT Slot 1	CT Slot 2	CT Slot 3	CT Slot 4
<b>Class code</b>	100 (0x64)	101 (0x65)	102 (0x66)	103 (0x67)	104 (0x68)	105 (0x69)
<b>Instance</b>	Menu					
<b>Attribute</b>	Parameter					
<b>Read code</b>	14 (0x0E) Get_Attribute_Single					
<b>Write code</b>	16 (0x10) Set_Attribute_Single					

#### NOTE

An instance value of 0 is not a valid value in this context, therefore an instance value of 200 (0xC8) should be used to access menu 0 parameters. For more information on the *Control Techniques* object see section 9.4.21 *Control Techniques objects* on page 112.

### 9.4.5 Cyclic (implicit or polled) data transfer

Cyclic data is a method of data transfer that must be setup during network configuration, but is transmitted automatically at the determined rate once configuration is complete.

EtherNet/IP transfers cyclic data using assembly objects, "cyclic data" is sometimes referred to as "Polled data" or "implicit data".

The terms "input" and "output" refer to data from the perspective of the PLC, an "output" assembly object transfers data from the PLC to the drive, an "input" assembly object transfers data from the drive to the PLC.

#### NOTE

Some PLCs provide the option of transmitting a configuration assembly object. The Ethernet interface does not use a configuration object; if one is required by the PLC then instance 1 should be specified with a length of 0 bytes.

### 9.4.6 Configuring EtherNet/IP cyclic parameters

In order to use cyclic data over EtherNet/IP, the EtherNet/IP interface must be configured to map the required parameter data to the assembly object.

For drive parameter access, object 100 (0x64) is used for reading parameters and object 101 (0x65) is used for writing parameters. The pre-defined assembly objects as listed in Table 9-8 *Supported drive assembly objects* can also be configured as cyclic data.

### 9.4.7 Assembly objects

An assembly object is an object which contains a group of attributes to control or monitor the drive operation. These attributes can be members of EtherNet/IP objects or drive parameters. The Ethernet interface supports a series of standard assembly objects and two *Control Techniques* objects (100 and 101) to access the drive parameters (see Table 9-8 *Supported drive assembly objects* on page 102).

#### NOTE

Conformance with the pre-defined assembly objects specification can only be guaranteed if the speed reference configuration of the drive has not been changed from the default settings. For information on setting default values, refer to the appropriate *Control User Guide*.

Table 9-8 Supported drive assembly objects

Assembly object name	Class		Length (Bytes)	Type	Default Mappings	
	Decimal	Hex (0x)			Bytes 0 to 3	Bytes 4 to 7
PrimaryI	100	64	4 to 80	Input	0.10.040	0.02.001
BscSpdCtrlI	70	46	4	Input		
ExtSpdCtrlI	71	47	4	Input		
SpdTrqCtrlI	72	48	6	Input		
ExtSpdTrqCtrlI	73	49	6	Input		
PrimaryO	101	65	4 to 80	Output	0.06.042	0.01.021
BscSpdCtrlO	20	14	4	Output		
ExtSpdCtrlO	21	15	4	Output		
SpdTrqCtrlO	22	16	6	Output		
ExtSpdTrqCtrlO	23	17	6	Output		

### 9.4.8 Basic speed control

#### Output assembly object 0x14 (20<sub>10</sub>)

The PLC or scanner must be configured for 4 output bytes (or 2 output words) if this assembly object is to be used.

Table 9-9 Basic speed control

Data word	Function
Word 0	Basic control word.
Word 1	Speed reference ( <i>SpeedRef</i> ).

#### Basic control word

The basic control word consists of 2 bytes (16 bits), with only 2 bits of the low byte being used as shown below.

b15	b14	b13	b12	b11	b10	b9	b8
b7	b6	b5	b4	b3	b2	b1	b0
					FaultRst		RunFwd

The individual bit functions are described as follows:

Name	Control Word	Description
RunFwd	b0	Set this bit to command the drive to run in the forward direction.
FaultRst	b2	A 0 to 1 transition will reset the drive if the drive was in a trip state.

#### NOTE

For the drive to run at the speed specified in Word 1, Pr 0.06.043 must be ON and bit 0, bit 7 and bit 8 of the drive control word (Pr 0.06.042) must all be set to 1 and the external hardware enable signal must be present.

The individual bit functions for the drive control word are shown in Table 9-10 below.

**Table 9-10 Drive control word bit functions**

Bit	Function	Equivalent parameter
0	Drive enable	Pr <b>0.06.015</b>
1	Run forward	Pr <b>0.06.030</b>
2	Jog forward	Pr <b>0.06.031</b>
3	Run reverse	Pr <b>0.06.032</b>
4	Forward/reverse	Pr <b>0.06.033</b>
5	Run	Pr <b>0.06.034</b>
6	Not stop	Pr <b>0.06.039</b>
7	Auto/manual	N/A
8	Analog/preset reference	Pr <b>0.01.042</b>
9	Jog reverse	Pr <b>0.06.037</b>
10	Reserved	N/A
11	Reserved	N/A
12	Trip drive	N/A
13	Reset drive	Pr <b>0.10.033</b>
14	Keypad watchdog	N/A

**Speed reference (*SpeedRef*)**

The speed reference word utilises 2 bytes (16 bits) as shown below.

b15	b14	b13	b12	b11	b10	b9	b8
SpeedRef (high byte)							
b7	b6	b5	b4	b3	b2	b1	b0
SpeedRef (low byte)							

For more information on the setting of the speed reference see Table 9-32 AC/DC Drive object attributes on page 111.

**9.4.9 Extended speed control**

**Output assembly object 0x15 (21<sub>10</sub>)**

The PLC or scanner must be configured for 4 output bytes (or 2 output words) if this assembly object is to be used.

**Table 9-11 Extended speed control**

Data word	Function
Word 0	Extended control word.
Word 1	Speed reference ( <i>SpeedRef</i> ).

**Extended control word**

The extended control word consists of 2 bytes (16 bits), with only the low byte used as shown.

b15	b14	b13	b12	b11	b10	b9	b8
b7	b6	b5	b4	b3	b2	b1	b0
NetRef		NetCtrl			FaultRst	RunRev	RunFwd

The individual bit functions are described as follows:

Name	Control Word	Description
RunFwd	b0	Set this bit to command the drive to run in the forward direction.
RunRev	b1	Set this bit to command the drive to run in the reverse direction.
FaultRst	b2	A 0 to 1 transition will reset the drive if the drive was in a trip state.
NetCtrl	b5	Used in conjunction with Pr <b>0.06.043</b> to enable the drive control word bits b0-b6 and bit 9 (Pr <b>0.06.042</b> ).
NetRef	b6	Set this bit to command the drive to use the remote speed reference value specified in Word 1.

**NOTE**

For the drive to run at the speed specified in Word 1, Pr **0.06.043** must be ON and bit 0, bit 7 and bit 8 of the drive control word (Pr **0.06.042**) must all be set to 1 and the external hardware enable signal must be present.

**NOTE**

For information on the drive control word see Table 9-10 Drive control word bit functions on page 103.

**NOTE**

Conformance with the pre-defined assembly objects specification can only be guaranteed if the speed reference configuration of the drive has not been changed from the default settings. For information on setting default values, refer to the appropriate Control User Guide.

**Speed reference (*SpeedRef*)**

The speed reference word utilises 2 bytes (16 bits) as shown below.

b15	b14	b13	b12	b11	b10	b9	b8
SpeedRef (high byte)							
b7	b6	b5	b4	b3	b2	b1	b0
SpeedRef (low byte)							

For more information on the setting of the speed reference see Table 9-32 AC/DC Drive object attributes on page 111.

**9.4.10 Basic speed and torque control**

**Output assembly object 0x16 (22<sub>10</sub>)**

The PLC or scanner must be configured for 6 output bytes (or 3 output words) if this assembly object is to be used.

**Table 9-12 Basic speed and torque control**

Data Word	Function
Word 0	Basic control word.
Word 1	Speed reference ( <i>SpeedRef</i> ).
Word 2	Torque reference ( <i>TorqueRef</i> ).

**Basic control word**

The basic control word consists of 2 bytes (16 bits), with only 2 bits of the low byte being used as shown below.

b15	b14	b13	b12	b11	b10	b9	b8
b7	b6	b5	b4	b3	b2	b1	b0
					FaultRst	RunFwd	

The individual bit functions are described as follows:

Name	Control Word	Description
RunFwd	b0	Set this bit to command the drive to run in the forward direction.
FaultRst	b2	A 0 to 1 transition will reset the drive if the drive was in a trip state.

**NOTE**

For the drive to run at the speed specified in Word 1, Pr **0.06.043** must be ON and bit 0, bit 7 and bit 8 of the drive control word (Pr **0.06.043**) must all be set to 1.

**NOTE**

For information on the drive control word see *Table 9-10 Drive control word bit functions* on page 103.

**Speed reference (SpeedRef)**

The speed reference word utilises 2 bytes (16 bits) as shown below.

b15	b14	b13	b12	b11	b10	b9	b8
SpeedRef (high byte)							

b7	b6	b5	b4	b3	b2	b1	b0
SpeedRef (low byte)							

For more information on the setting of the speed reference see *Table 9-32 AC/DC Drive object attributes* on page 111.

**Torque reference (TorqueRef)**

The torque reference word utilises 2 bytes (16 bits) as shown below.

b15	b14	b13	b12	b11	b10	b9	b8
TorqueRef (high byte)							

b7	b6	b5	b4	b3	b2	b1	b0
TorqueRef (low byte)							

For more information on the setting of the torque reference see *Table 9-32 AC/DC Drive object attributes* on page 111.

**9.4.11 Extended speed and torque control**

**Output assembly object 0x17 (23<sub>10</sub>)**

The PLC or scanner must be configured for 6 output bytes (or 3 output words) if this assembly object is to be used.

**Table 9-13 Extended speed and torque control**

Data word	Function
Word 0	Extended control word.
Word 1	Speed reference ( <i>SpeedRef</i> ).
Word 2	Torque reference ( <i>TorqueRef</i> ).

**Extended control word**

The extended control word consists of 2 bytes (16 bits), with only 5 bits of the low byte used as shown below.

b15	b14	b13	b12	b11	b10	b9	b8

b7	b6	b5	b4	b3	b2	b1	b0
NetRef		NetCtrl			FaultRst	RunRev	RunFwd

The individual bit functions are described as follows:

Name	Control Word	Description
RunFwd	b0	Set this bit to command the drive to run in the forward direction.
RunRev	b1	Set this bit to command the drive to run in the reverse direction.
FaultRst	b2	A 0 to 1 transition will reset the drive if the drive was in a trip state.
NetCtrl	b5	Used in conjunction with Pr <b>06.043</b> to enable the drive control word bits b0-b6 and bit 9 (Pr <b>06.042</b> ).
NetRef	b6	Set this bit to command the drive to use the remote speed reference value specified in Word 1.

**NOTE**

For the drive to run at the speed specified in Word 1, Pr **06.043** must be ON and bit 0, bit 7 and bit 8 of the drive control word (Pr **06.042**) must all be set to 1 and the external hardware enable signal must be present.

**NOTE**

For information on the drive control word see *Table 9-10 Drive control word bit functions* on page 103.

**Speed reference (SpeedRef)**

The speed reference word utilises 2 bytes (16 bits) as shown below.

b15	b14	b13	b12	b11	b10	b9	b8
SpeedRef (high byte)							

b7	b6	b5	b4	b3	b2	b1	b0
SpeedRef (low byte)							

For more information on the setting of the speed reference see *Table 9-32 AC/DC Drive object attributes* on page 111.

**Torque reference (TorqueRef)**

The torque reference word utilises 2 bytes (16 bits) as shown below.

b15	b14	b13	b12	b11	b10	b9	b8
TorqueRef (high byte)							

b7	b6	b5	b4	b3	b2	b1	b0
TorqueRef (low byte)							

For more information on the setting of the torque reference see *Table 9-32 AC/DC Drive object attributes* on page 111.

**9.4.12 Basic speed feedback**

**Input assembly object 0x46 (70<sub>10</sub>)**

The PLC or scanner must be configured for 4 input bytes (or 2 input words) if this assembly object is to be used.

**Table 9-14 Basic speed feedback**

Data word	Function
Word 0	Basic status word.
Word 1	Speed feedback ( <i>SpeedActual</i> ).

**Basic status word**

The basic status word consists of 2 bytes (16 bits), with only 2 bits of the low byte used as shown below.

b15	b14	b13	b12	b11	b10	b9	b8

b7	b6	b5	b4	b3	b2	b1	b0
					Running 1 (Fwd)	Faulted	

The individual bit functions are described as follows:

Bit	Name	Description
b0	Faulted	Indicates whether the drive is OK or tripped (0=OK, 1=Tripped).
b2	Running1 (Fwd)	Indicates if the drive is running in the forward direction (0=False, 1=True).

### Speed feedback (*SpeedActual*)

The speed feedback word utilises 2 bytes (16 bits) as shown below.

b15	b14	b13	b12	b11	b10	b9	b8
SpeedActual (high byte)							
b7	b6	b5	b4	b3	b2	b1	b0
SpeedActual (low byte)							

For more information on the speed feedback see *Table 9-32 AC/DC Drive object attributes* on page 111.

### 9.4.13 Extended speed feedback

#### Input assembly object 0x47 (71<sub>10</sub>)

The PLC or scanner must be configured for 4 input bytes (or 2 input words) if this assembly object is to be used.

**Table 9-15 Extended speed feedback**

Data word	Function
Word 0	Extended status word.
Word 1	Speed feedback ( <i>SpeedActual</i> ).

#### Extended status word

The extended status word consists of 2 bytes (16 bits), with the bits having functions as shown below.

b15	b14	b13	b12	b11	b10	b9	b8
DriveState							
b7	b6	b5	b4	b3	b2	b1	b0
At Reference	RefFrom Net	CtrlFrom Net	Ready	Running2 (Rev)	Running1 (Fwd)	Warning	Faulted

The DriveState byte returns a code to indicate the operating state of the drive as shown in *Table 9-16* following.

**Table 9-16 Drive State codes**

Code	b15 - b8	State	Description
1	00000001	Startup	This state is skipped over on CT drives.
2	00000010	Not_Ready	Inhibit.
3	00000011	Ready	Ready.
4	00000100	Enabled	Run or Stop.
5	00000101	Stopping	Deceleration or Injection.
6	00000110	Fault_Stop	AC_UU (this will only occur if Mains Loss is enabled).
7	00000111	Faulted	Tripped.
0	00000000	Vendor Specific	All other DriveType states, e.g. Scan, Orienting, Regen Active, etc.

The individual bits of the low byte of the extended status word are described below.

**Table 9-17 Extended status word (low byte)**

Name	Bit	Description
Faulted	b0	Indicates whether the drive is OK or tripped. 0=OK (Pr <b>0.10.001</b> =1). 1=Tripped (Pr <b>0.10.001</b> =0).
Warning	b1	Indicates if one of the drive alarms is active.
Running1 (Fwd)	b2	Indicates if the drive is running in the forward direction. 0=False, 1=True.
Running2 (Rev)	b3	Indicates if the drive is running in the reverse direction. 0=False, 1=True.
Ready	b4	The 'Ready' bit is set depending on which state the drive is in. Ready = True. Enabled = True. Stopping = True. All others = False.
CtrlFromNet	b5	Indicates if the drive is being controlled from the 'Drive Control Word'. 0=False, 1=True.
RefFromNet	b6	Indicates if the speed reference is derived from Pr <b>0.01.021</b> . 0=False (Pr <b>0.01.050</b> <>1 OR Pr <b>0.01.049</b> <>3). 1=True (Pr <b>0.01.050</b> =1 AND Pr <b>0.01.049</b> =3).
AtReference	b7	Indicates if the drive speed has reached the set reference. 0=False (Pr <b>0.10.006</b> =0). 1=True (Pr <b>0.10.006</b> =1).

### Speed feedback (*SpeedActual*)

The speed feedback word utilises 2 bytes (16 bits) as shown below.

b15	b14	b13	b12	b11	b10	b9	b8
SpeedActual (high byte)							
b7	b6	b5	b4	b3	b2	b1	b0
SpeedActual (low byte)							

For more information on the speed feedback see *Table 9-32 AC/DC Drive object attributes* on page 111.

### 9.4.14 Basic speed and torque feedback

#### Input assembly object 0x48 (72<sub>10</sub>)

The PLC or scanner must be configured for 6 input bytes (or 3 input words) if this assembly object is to be used.

**Table 9-18 Basic speed and torque feedback**

Data word	Function
Word 0	Basic status word.
Word 1	Speed feedback ( <i>SpeedActual</i> ).
Word 2	Torque feedback ( <i>TorqueActual</i> ).

#### Basic status word

The basic status word consists of 2 bytes (16 bits), with only the low byte used as shown below.

b15	b14	b13	b12	b11	b10	b9	b8
b7	b6	b5	b4	b3	b2	b1	b0
					Running1 (Fwd)	Faulted	

The individual bit functions are described as follows:

Bit	Name	Description
b0	Faulted	Indicates whether the drive is OK or tripped (0=OK, 1=Tripped).
b2	Running1 (Fwd)	Indicates if the drive is running in the forward direction (0=False, 1=True).

#### Speed feedback (*SpeedActual*)

The speed feedback word utilises 2 bytes (16 bits) as shown below.

b15	b14	b13	b12	b11	b10	b9	b8
SpeedActual (high byte)							
b7	b6	b5	b4	b3	b2	b1	b0
SpeedActual (low byte)							

For more information on the speed feedback see *Table 9-32 AC/DC Drive object attributes* on page 111.

#### Torque feedback (*TorqueActual*)

The torque feedback word utilises 2 bytes (16 bits) as shown below.

b15	b14	b13	b12	b11	b10	b9	b8
TorqueActual (high byte)							
b7	b6	b5	b4	b3	b2	b1	b0
TorqueActual (low byte)							

For more information on the torque feedback see *Table 9-32 AC/DC Drive object attributes* on page 111.

### 9.4.15 Extended speed and torque feedback

#### Input assembly object 0x49 (73<sub>10</sub>)

The PLC or scanner must be configured for 6 input bytes (or 3 input words) if this assembly object is to be used.

**Table 9-19 Basic speed and torque feedback**

Data word	Function
Word 0	Extended status word.
Word 1	Speed feedback ( <i>SpeedActual</i> ).
Word 2	Torque feedback ( <i>TorqueActual</i> ).

#### Extended status word

The extended status word consists of 2 bytes (16 bits), with the bits having functions as shown below.

b15	b14	b13	b12	b11	b10	b9	b8
DriveState							
b7	b6	b5	b4	b3	b2	b1	b0
At Reference	RefFrom Net	CtrlFrom Net	Ready	Running2 (Rev)	Running1 (Fwd)	Warning	Faulted

The DriveState byte returns a code to indicate the operating state of the drive as shown in Table 9-20.

**Table 9-20 Drive State codes**

Code	b15 - b8	State	Description
1	00000001	Startup	This state is skipped over on CT drives.
2	00000010	Not_Ready	Inhibit.
3	00000011	Ready	Ready.
4	00000100	Enabled	Run or Stop.
5	00000101	Stopping	Deceleration or Injection.
6	00000110	Fault_Stop	AC_UU (this will only occur if Mains Loss is enabled).
7	00000111	Faulted	Tripped.
0	00000000	Vendor Specific	All other DriveType states, e.g. Scan, Orienting, Regen Active, etc.

The individual bits of the low byte of the extended status word are described in Table 9-21 *Extended status word (low byte)* on page 106.

**Table 9-21 Extended status word (low byte)**

Name	Bit	Description
Faulted	b0	Indicates whether the drive is OK or tripped. 0=OK (Pr 0.10.001=1). 1=Tripped (Pr 0.10.001=0).
Warning	b1	Indicates if one of the drive alarms is active.
Running1 (Fwd)	b2	Indicates if the drive is running in the forward direction. 0=False, 1=True.
Running2 (Rev)	b3	Indicates if the drive is running in the reverse direction. 0=False, 1=True.
Ready	b4	The 'Ready' bit is set depending on which state the drive is in. Ready = True. Enabled = True. Stopping = True. All others = False.
CtrlFromNet	b5	Indicates if the drive is being controlled from the 'Drive Control Word'. 0=False, 1=True.
RefFromNet	b6	Indicates if the speed reference is derived from Pr 0.01.021. 0=False (Pr 0.01.050<>1 OR Pr 0.01.049<>3). 1=True (Pr 0.01.050=1 AND Pr 0.01.049=3).
AtReference	b7	Indicates if the drive speed has reached the set reference. 0=False (Pr 0.10.006=0). 1=True (Pr 0.10.006=1).

#### Speed feedback (*SpeedActual*)

The speed feedback word utilises 2 bytes (16 bits) as shown below.

b15	b14	b13	b12	b11	b10	b9	b8
SpeedActual(high byte)							
b7	b6	b5	b4	b3	b2	b1	b0
SpeedActual (low byte)							

For more information on the speed feedback see *Table 9-32 AC/DC Drive object attributes* on page 111.

### Torque feedback (*TorqueActual*)

The torque feedback word utilises 2 bytes (16 bits) as shown below.

b15	b14	b13	b12	b11	b10	b9	b8
TorqueActual (high byte)							
b7	b6	b5	b4	b3	b2	b1	b0
TorqueActual (low byte)							

For more information on the torque feedback see *Table 9-32 AC/DC Drive object attributes* on page 111.

### 9.4.16 Object Model

The Object Model has the following object classes present.

**Table 9-22 Supported Objects**

Object Class	Class Code		Number of Instances	Effect
	Decimal	Hex (0x)		
Identity	1	01	1	Provides device specific information.
Assembly	4	04	16	Defines the I/O data format (parameter mapping).
Motor Data	40	28	2	Defines the motor data.
Control Supervisor	41	29	1	Provides drive control and monitoring information.
AC/DC Drive	42	2A	1	Provides drive configuration and running state information.
CT Group	100	64	<No. of menus>	Provides access to drive parameters.
CT This Slot	101	65	<No. of menus>	Provides access to the local option module parameters.
CT Slot 1	102	66	<No. of menus>	Provides access to the option module parameters in slot 1.
CT Slot 2	103	67	<No. of menus>	Provides access to the option module parameters in slot 2.
CT Slot 3	104	69	<No. of menus>	Provides access to the onboard Ethernet interface parameters.

### 9.4.17 Identity object

**Class:** 0x01 (1<sub>10</sub>)

The identity object provides identification of and general information about the device.

**Table 9-23 Identity object**

Attribute	Access	Name	Data Type
1	Get	VendorID	UINT
2	Get	DeviceType	UINT
3	Get	ProductCode	UINT
4	Get	Revision	USINT
6	Get	SerialNumber	UDINT
7	Get	ProductName	SHORT_STRING

### Vendor ID

<b>Name:</b>	VendorID		
<b>Class</b>	0x01	<b>Default</b>	0x101 (257 <sub>10</sub> )
<b>Instance</b>	0x01	<b>Data Type</b>	UINT
<b>Attribute</b>	0x01	<b>Access</b>	Get

Returns the vendor ID code 0x101 (257<sub>10</sub>) for *Control Techniques*.

### Device type

<b>Name:</b>	DeviceType		
<b>Class</b>	0x01	<b>Default</b>	0x02
<b>Instance</b>	0x01	<b>Data Type</b>	UINT
<b>Attribute</b>	0x02	<b>Access</b>	Get

Returns the device type code. The following codes are used:

Device Type code	Drive type
0x02	AC Drive

### Product code

<b>Name:</b>	Product Code		
<b>Class</b>	0x01	<b>Default</b>	See below
<b>Instance</b>	0x01	<b>Data Type</b>	UINT
<b>Attribute</b>	0x03	<b>Access</b>	Get

Returns a 16 bit value to identify the drive type and drive mode and also links a node to the installed EDS files. The product code is calculated as shown in *Table 9-24 Product code bit allocation* below.

**Table 9-24 Product code bit allocation**

b15	b14	b13	b12	b11	b10	b9	b8	b7	b6	b5	b4	b3	b2	b1	b0
Drive Type					Drive Derivative			Drive Mode			CIP code				

### Drive Type (b15 to b11)

The drive type is defined as follows:

Value	Drive Type
2	Digitax HD

### Drive Derivative (b10 to b6)

The drive derivative as shown in *Pr 0.11.028*.

For more information on the drive derivative codes please refer to the relevant drive documentation.

### Drive Mode (b5 to b3)

The drive operating mode is defined as follows:

Value	Operating Mode
0	Open-loop
1	RFC-A
2	RFC-S
3	Regen

### CIP code (b2 to b0)

The CIP (Common Industrial Protocol) interface code is defined as follows:

Value	Interface ID	Description
0	437	Unidrive M750 Factory Fit Ethernet
1	447	SI-DeviceNet
2	310	MCi210
3	433	SI-Ethernet

### Revision

<b>Name:</b>	Revision		
<b>Class</b>	0x01	<b>Default</b>	N/A
<b>Instance</b>	0x01	<b>Data Type</b>	ARRAY of USINT
<b>Attribute</b>	0x04	<b>Access</b>	Get

Returns 2 bytes to indicate the major and minor revision numbers of the Ethernet interface firmware version.

The Ethernet interface firmware version (*Pr 17.002*) consists of four 2-digit decimal numbers with the following significance:

[Major].[Minor].[Bugfix].[Build].

The revision code returns the major and minor revisions of the Ethernet interface firmware version in two unsigned bytes, the major revision being returned first followed by the minor revision.

**Table 9-25 Revision specification**

b7	b6	b5	b4	b3	b2	b1	b0
Major revision (Pr 17.002 / 1000000)							
R	Minor revision (Pr 17.002 / 10000) Mod 100						

Where "Mod 100" refers to the fractional value of the result from Pr 17.002/10000, (the value after the decimal point).

e.g. For a value of 12345678 in Pr 17.002 (12.34.56.78 on the keypad display), the major revision is 12 and the minor revision is 34.

The returned data will consist of 2 unsigned bytes, the first byte will be the major revision value 12 (0x0C) and the second byte will be the minor revision value 34 (0x22).

**Major revision**

b7	b6	b5	b4	b3	b2	b1	b0
0	0	0	0	1	1	0	0
Major revision = 12 (0x0C)							

**Minor revision**

b6	b5	b4	b3	b2	b1	b0
0	1	0	0	0	1	0
Minor revision = 34 (0x22)						

**Serial Number**

Name:	SerialNumber		
Class	0x01	Default	N/A
Instance	0x01	Data Type	UDINT
Attribute	0x06	Access	Get

Returns the lower 4 bytes (32 bits) of the Ethernet interface serial number.

The Ethernet interface serial number is contained within two adjacent parameters, Pr 17.004 *Serial Number LS* displays the least 8 significant decimal digits and Pr 17.005 *Serial Number MS* displays the most 8 significant decimal digits.

For example, if the serial number of the onboard Ethernet interface is 123456789 then Pr 17.005 *Serial Number MS* will display 1 and Pr 17.004 *Serial Number LS* will display 23456789.

The Ethernet interface serial number is set during manufacture and cannot be changed.

**Product Name**

Name:	ProductName			
Class	0x01	Default	Onboard Ethernet	Factory Fit Ethernet
			SI-Ethernet	SI-Ethernet
Instance	0x01	Data Type	SHORT_STRING	
Attribute	0x07	Access	Get	

Returns the product name as a short string of ASCII Bytes. The first byte specifies the number of following bytes that constitute the product name.

**9.4.18 Motor data object**

Class: 0x28 (40<sub>10</sub>)

There are 2 instances of the Motor data object. Instance 1 will represent menu 5 motor information (motor 1) and instance 2 will represent menu 21 motor information (motor 2). The instance being used by the other dependant objects will be determined by Pr 0.11.045, to use the second motor map objects (instance 2), Pr 0.11.045 should be set to *Motor 2*. Pr 0.11.045 is polled in the background task, so the user should be aware that during motor map changeover, the RPM speed reference

may not be accurate. The available attributes and associated functions for the AC motor data object are shown in Table 9-26 *AC Motor data object attributes* below.

**Table 9-26 AC Motor data object attributes**

AC Motor Instance Attributes			Drive Parameter	
Attribute ID	Name	Access	Instance 1	Instance 2
0x03 (3 <sub>10</sub> )	MotorType (*)	Get/Set	None	None
0x06 (6 <sub>10</sub> )	RatedCurrent	Get/Set	Pr 0.05.007 (scaled to 100 mA units)	Pr 0.21.007 (scaled to 100 mA units)
0x07 (7 <sub>10</sub> )	RatedVoltage	Get/Set	Pr 0.05.009	Pr 0.21.009
0x09 (9 <sub>10</sub> )	RatedFreq	Get/Set	Pr 0.05.006 (scaled to Hz)	Pr 0.21.006 (scaled to Hz)
0x0F (15 <sub>10</sub> )	BaseSpeed	Get/Set	Pr 0.05.008 (scaled to rpm units)	Pr 0.21.008 (scaled to rpm units)
0x64 (100 <sub>10</sub> )	Motor2Select	Get	Pr 0.21.015	Pr 0.21.015
		Set	Pr 0.11.045	Pr 0.11.045

(\* The MotorType attribute has no effect on drive operation, it is only used to provide information to the user as shown in Table 9-27 *Supported motor types* below).

**Table 9-27 Supported motor types**

Value	Motor Type
6	Wound rotor induction motor
7	Squirrel cage induction motor (default)
9	Sinusoidal PM BL motor
10	Trapezoidal PM BL motor

**NOTE**

In Open loop mode, only values 6 and 7 will be supported.

**Motor type**

Name:	MotorType1		
Class	0x28	Default	7
Instance	0x01	Data Type	USINT
Attribute	0x03	Access	Get/Set

Returns or sets the motor type to be used by the drive for instance 1.

Name:	MotorType2		
Class	0x28	Default	7
Instance	0x02	Data Type	USINT
Attribute	0x03	Access	Get/Set

Returns or sets the motor type to be used by the drive for instance 2.

**Rated current**

Name:	RatedCurrent1		
Class	0x28	Default	Pr 0.05.007 / 10
Instance	0x01	Data Type	USINT
Attribute	0x06	Access	Get/Set

Returns or sets the rated motor current in Amps for instance 1. This attribute is linked to Pr 0.05.007.

Set Pr 0.05.007 = RatedCurrent1 \* 10.

Get RatedCurrent1 = Pr 0.05.007 / 10.

<b>Name:</b>	<b>RatedCurrent2</b>		
<b>Class</b>	0x28	<b>Default</b>	Pr 0.21.007 / 10
<b>Instance</b>	0x02	<b>Data Type</b>	USINT
<b>Attribute</b>	0x06	<b>Access</b>	Get/Set

Returns or sets the rated motor current in Amps for instance 2. This attribute is linked to Pr 0.21.007.

Set Pr 0.21.007 = RatedCurrent2 \* 10.

Get RatedCurrent2 = Pr 0.21.007 / 10.

#### Rated voltage

<b>Name:</b>	<b>RatedVoltage1</b>		
<b>Class</b>	0x28	<b>Default</b>	Pr 0.05.009
<b>Instance</b>	0x01	<b>Data Type</b>	USINT
<b>Attribute</b>	0x07	<b>Access</b>	Get/Set

Returns or sets the rated motor voltage in Volts for instance 1. This attribute is linked to Pr 0.05.009.

<b>Name:</b>	<b>RatedVoltage2</b>		
<b>Class</b>	0x28	<b>Default</b>	Pr 0.21.009
<b>Instance</b>	0x02	<b>Data Type</b>	USINT
<b>Attribute</b>	0x07	<b>Access</b>	Get/Set

Returns or sets the rated motor voltage in Volts for instance 2. This attribute is linked to Pr 0.21.009.

#### Rated frequency

<b>Name:</b>	<b>RatedFreq1</b>		
<b>Class</b>	0x28	<b>Default</b>	Pr 0.05.006 / 10
<b>Instance</b>	0x01	<b>Data Type</b>	USINT
<b>Attribute</b>	0x09	<b>Access</b>	Get/Set

Returns or sets the rated motor frequency in Hertz for instance 1. This attribute is linked to Pr 0.05.006.

Set Pr 0.05.006 = RatedFreq1 \* 10.

Get RatedFreq1 = Pr 0.05.006 / 10.

<b>Name:</b>	<b>RatedFreq2</b>		
<b>Class</b>	0x28	<b>Default</b>	Pr 0.21.006 / 10
<b>Instance</b>	0x02	<b>Data Type</b>	USINT
<b>Attribute</b>	0x09	<b>Access</b>	Get/Set

Returns or sets the rated motor frequency in Hertz for instance 2. This attribute is linked to Pr 21.006.

Set Pr 0.21.006 = RatedFreq2 \* 10.

Get RatedFreq2 = Pr 0.21.006 / 10.

#### Base speed

<b>Name:</b>	<b>BaseSpeed1</b>		
<b>Class</b>	0x28	<b>Default</b>	Pr 0.05.008
<b>Instance</b>	0x01	<b>Data Type</b>	USINT
<b>Attribute</b>	0x0F	<b>Access</b>	Get/Set

Returns or sets the base speed of the motor in RPM for instance 1. This attribute is linked to Pr 0.05.008.

<b>Name:</b>	<b>BaseSpeed2</b>		
<b>Class</b>	0x28	<b>Default</b>	Pr 0.21.008
<b>Instance</b>	0x02	<b>Data Type</b>	USINT
<b>Attribute</b>	0x0F	<b>Access</b>	Get/Set

Returns or sets the base speed of the motor in RPM for instance 2. This attribute is linked to Pr 0.21.008.

#### Motor2Select

<b>Name:</b>	<b>Motor2Select</b>		
<b>Class</b>	0x28	<b>Default</b>	
<b>Instance</b>	0x01	<b>Data Type</b>	USINT
<b>Attribute</b>	0x64	<b>Access</b>	Get/Set

Selects between Motor 1 and Motor 2. This attribute is linked to Pr 0.11.045. When this bit is set to 1, Motor 2 will be active.

#### NOTE

Any change in this attribute will be implemented when the drive is disabled.

#### 9.4.19 Control Supervisor object

**Class:** 0x29 (41<sub>10</sub>)

The Control Supervisor object provides access to various attributes which control or monitor the drive running state. The available attributes and their associated functions are shown in Table 9-28 following.

**Table 9-28 Control Supervisor object attribute**

Attribute ID		Access	Name	Parameter dependence
Decimal	Hex (0x)			
3	03	Get/Set	RunFwd	0.06.042 bit1
4	04	Get/Set	RunRev	0.06.042 bit3
5	05	Get/Set	NetCtrl	0.06.042 bit7
6	06	Get	State	See Table 9-29 Control Supervisor state attributes on page 110
7	07	Get	RunningFwd	1 (0.10.040 AND 0x2002) = 0x0002
				0 (0.10.040 AND 0x2002) <> 0x0002
8	08	Get	RunningRev	1 (0.10.040 AND 0x2002) = 0x2002
				0 (0.10.040 AND 0x2002) <> 0x2002
9	09	Get	Ready	See Table 9-29 Control Supervisor state attributes on page 110
10	0A	Get	Faulted	Inverse of 0.10.001
11	0B	Get	Warning	0.10.019
12	0C	Get/Set	FaultRst	Sets 0.10.038 to 100 on a 0 to 1 transition
13	0D	Get	FaultCode	See Table 9-29 Control Supervisor state attributes on page 110
15	0F	Get	CtrlFromNet	0.06.042 bit7 AND 0.06.043
102	66	Get/Set	DriveEnable	0.06.042 bit0

#### RunFwd

<b>Name:</b>	<b>RunFwd</b>		
<b>Class</b>	0x29	<b>Default</b>	N/A
<b>Instance</b>	0x01	<b>Data Type</b>	USINT
<b>Attribute</b>	0x03	<b>Access</b>	Get/Set

Set to 1 to run the drive in the forward direction.

Get/Set Pr 0.06.042 (bit 1).

#### RunRev

<b>Name:</b>	<b>RunRev</b>		
<b>Class</b>	0x29	<b>Default</b>	N/A
<b>Instance</b>	0x01	<b>Data Type</b>	USINT
<b>Attribute</b>	0x04	<b>Access</b>	Get/Set

Set to 1 to run the drive in the reverse direction.

Get/Set Pr **0.06.042** (bit 3).

### NetCtrl

<b>Name:</b>	NetCtrl		
<b>Class</b>	0x29	<b>Default</b>	N/A
<b>Instance</b>	0x01	<b>Data Type</b>	USINT
<b>Attribute</b>	0x05	<b>Access</b>	Get/Set

Switches between terminal and fieldbus control.

Get/Set Pr **0.06.042** (bit 7)

0 = Terminal control.

1 = Fieldbus control.

### State

<b>Name:</b>	State		
<b>Class</b>	0x29	<b>Default</b>	N/A
<b>Instance</b>	0x01	<b>Data Type</b>	USINT
<b>Attribute</b>	0x06	<b>Access</b>	Get

This returns a code to indicate the current running state of the drive as shown in Table 9-29 following.

**Table 9-29 Control Supervisor state attributes**

Code	State	Parameter Dependence	Description
1	Startup	N/A	This state is skipped over
2	Not_Ready	<b>0.10.101</b> = 0	Inhibit
3	Ready	<b>0.10.101</b> = 1	Ready
4	Enabled	<b>0.10.101</b> = 2 OR <b>0.10.101</b> = 4	Stop or Run
5	Stopping	<b>0.10.101</b> = 6 OR <b>0.10.101</b> = 7	Decelerating or DC injection braking
6	Fault_Stop	<b>0.10.101</b> = 5	AC supply loss
7	Faulted	<b>0.10.101</b> = 9	Tripped
0	Vendor Specific	<b>0.10.101</b> = All other drive states	See parameter reference guide

### RunningFwd

<b>Name:</b>	RunningFwd		
<b>Class</b>	0x29	<b>Default</b>	N/A
<b>Instance</b>	0x01	<b>Data Type</b>	USINT
<b>Attribute</b>	0x07	<b>Access</b>	Get

Indicates that the drive is running in the forward direction.

This attribute will be set to 1 when Pr **0.10.014** = 0 and Pr **0.10.002** = 1.

### RunningRev

<b>Name:</b>	RunningRev		
<b>Class</b>	0x29	<b>Default</b>	N/A
<b>Instance</b>	0x01	<b>Data Type</b>	USINT
<b>Attribute</b>	0x08	<b>Access</b>	Get

Indicates that the drive is running in the reverse direction.

This attribute will be set to 1 when Pr **0.10.014** = 0 and Pr **0.10.002** = 1.

### Ready

<b>Name:</b>	Ready		
<b>Class</b>	0x29	<b>Default</b>	N/A
<b>Instance</b>	0x01	<b>Data Type</b>	USINT
<b>Attribute</b>	0x09	<b>Access</b>	Get

The Ready attribute will be set in accordance with the state as shown in Table 9-30.

**Table 9-30 Control Supervisor Ready attributes**

Code	State	Ready state
3	Ready	True
4	Enabled	True
5	Stopping	True
All others		False

### Faulted

<b>Name:</b>	Faulted		
<b>Class</b>	0x29	<b>Default</b>	N/A
<b>Instance</b>	0x01	<b>Data Type</b>	USINT
<b>Attribute</b>	0x0A	<b>Access</b>	Get

Indicates that the drive is tripped, i.e. not OK (inverse of Pr **0.10.001**).

Get 1 = Pr **0.10.001** = 0.

Get 0 = Pr **0.10.001** = 1.

### Warning

<b>Name:</b>	Warning		
<b>Class</b>	0x29	<b>Default</b>	N/A
<b>Instance</b>	0x01	<b>Data Type</b>	USINT
<b>Attribute</b>	0x0B	<b>Access</b>	Get

Indicates that one of the drive alarms is active.

Get Pr **0.10.019**.

### FaultRst

<b>Name:</b>	FaultRst		
<b>Class</b>	0x29	<b>Default</b>	N/A
<b>Instance</b>	0x01	<b>Data Type</b>	USINT
<b>Attribute</b>	0x0C	<b>Access</b>	Get/Set

Resets the drive from a tripped condition.

Sets Pr **0.10.038** to 100 on a 0 to 1 transition.

### FaultCode

<b>Name:</b>	FaultCode		
<b>Class</b>	0x29	<b>Default</b>	N/A
<b>Instance</b>	0x01	<b>Data Type</b>	USINT
<b>Attribute</b>	0x0D	<b>Access</b>	Get

The fault code attribute will return the ODVA fault code as follows:

If the drive is not OK, the drive fault code is obtained from Pr **0.10.020**, if the drive fault code is listed in Table 9-31, then the ODVA fault code as shown in Table 9-31 below will be returned.

If the drive fault code is not listed in Table 9-31 then the Ethernet interface will return the ODVA code as follows:

ODVA Fault Code = 0x1000 + drive fault code.

**Table 9-31 Control Supervisor fault code attributes**

Drive Fault Code	ODVA Fault Code	Drive Fault Code	ODVA Fault Code
1	0x3220	20	0x2310
2	0x3210	21	0x4300
3	0x2300	26	0x5112
4	0x7112	32	0x3130
6	0x9000		

### CtrlFromNet

<b>Name:</b>	CtrlFromNet		
<b>Class</b>	0x29	<b>Default</b>	N/A
<b>Instance</b>	0x01	<b>Data Type</b>	USINT
<b>Attribute</b>	0x0F	<b>Access</b>	Get

Indicates whether the drive is operating under fieldbus or terminal control.

This attribute will be set to 1 if Pr **0.06.042** (bit 7) = 1 and Pr **0.06.043** = 1 (fieldbus).

### DriveEnable

<b>Name:</b>	DriveEnable		
<b>Class</b>	0x29	<b>Default</b>	N/A
<b>Instance</b>	0x01	<b>Data Type</b>	USINT
<b>Attribute</b>	0x66	<b>Access</b>	Get/Set

Enables the drive. This puts the drive into the "Ready" state, allowing the **RunFwd** and **RunRev** attributes to control the drive. **RunFwd** and **RunRev** will have no effect if **DriveEnable** is not set to 1.

Get/Set Pr **0.06.042** bit 0.

#### NOTE

The external hardware enable signal must also be present before the drive will enter the Ready state.

### 9.4.20 AC/DC Drive object

**Class:** 0x2A (42<sub>10</sub>)

The AC/DC Drive object provides information on the drive running state and supports the following attributes:

**Table 9-32 AC/DC Drive object attributes**

Attribute ID	Name	Access	Parameter dependence
0x03 (3 <sub>10</sub> )	AtReference	Get	Pr <b>0.10.006</b>
0x04 (4 <sub>10</sub> )	NetRef	Get/Set	Pr <b>0.06.042</b> (bit 8)
0x06 (6 <sub>10</sub> )	DriveMode	Get/Set	(See Table 9-33 on page 111)
0x07 (7 <sub>10</sub> )	SpeedActual	Get	RFC-A or RFC-S Pr <b>0.03.002</b>
			Open Loop Pr <b>0.05.004</b>
0x08 (8 <sub>10</sub> )	SpeedRef	Get/Set	RFC-A or RFC-S Pr <b>0.01.021</b> (scaled to 0 decimal places)
		Get	Open Loop Pr <b>0.01.021</b> * 60 / <i>NofPP</i> (scaled to 0 decimal places)
		Set	Open Loop Pr <b>0.01.021</b> = SpeedRef * <i>NofPP</i> / 60 (scaled to 0 decimal places)
0x0B (11 <sub>10</sub> )	TorqueActual	Get	Pr <b>0.04.020</b> (scaled to 1 decimal place)
0x0C (12 <sub>10</sub> )	TorqueRef	Get/Set	Pr <b>0.04.008</b> (scaled to 1 decimal place)
0x1D (29 <sub>10</sub> )	RefFromNet	Get	1 Pr <b>0.01.049</b> =3 AND Pr <b>0.01.050</b> =1
			0 Pr <b>0.01.049</b> <>3 OR Pr <b>0.01.050</b> <>1

#### NOTE

*NofPP* = Number of Pole Pairs.

### AtReference

<b>Name:</b>	AtReference		
<b>Class</b>	0x2A	<b>Default</b>	N/A
<b>Instance</b>	0x01	<b>Data Type</b>	USINT
<b>Attribute</b>	0x03	<b>Access</b>	Get

Indicates that the drive is running at the requested speed.

Get Pr **0.10.006**

- 0 = Drive not running at requested speed.
- 1 = Drive running at requested speed.

### NetRef

<b>Name:</b>	NetRef		
<b>Class</b>	0x2A	<b>Default</b>	N/A
<b>Instance</b>	0x01	<b>Data Type</b>	USINT
<b>Attribute</b>	0x04	<b>Access</b>	Get/Set

Selects the source of the speed reference.

Get/Set Pr **0.06.042** bit 8

- 0 = analog speed reference.
- 1 = digital speed reference.

#### NOTE

The NetRef can only be changed between local and remote when the drive is configured in speed control mode. If a change is requested when in torque mode then a 'Device State Conflict' error code 0x10 will be returned.

### DriveMode

<b>Name:</b>	DriveMode		
<b>Class</b>	0x2A	<b>Default</b>	N/A
<b>Instance</b>	0x01	<b>Data Type</b>	USINT
<b>Attribute</b>	0x06	<b>Access</b>	Get/Set

DriveMode does not allow the operating mode of the drive to be changed. Pr **0.04.011** will be written to as shown in Table 9-33 below, provided that the drive is already in the correct operating mode.

**Table 9-33 AC/DC Drive object DriveMode attribute (Get)**

Access	DriveMode		Actual Drive Mode	Torque Mode (0.4.011)
	Value	Mode		
Get	1	Open Loop Speed	Open-loop	Speed control mode (0)
	2	Closed Loop Speed	RFC-A RFC-S	
	3	Torque Control	Open-loop	Torque control (3)
			RFC-A RFC-S	
0	User Defined	Regen	Don't care	
		Don't care	Torque control with speed override (2) or Coiler / uncoiler mode (3) or Speed control with torque feed-forward (4)	

**Table 9-34 AC/DC Drive object DriveMode attribute (Set)**

Access	DriveMode		Actual Drive Mode	Action
	Value	Mode		
Set	0	User Defined	Don't care	Return Invalid Attribute Value' (0x09)
	1	Open Loop Speed	Open-loop	Pr <b>0.04.011</b> = Speed control mode (0)
			RFC-A or RFC-S or Regen	Return 'Drive state conflict' error (0x10)
	2	Closed Loop Speed	RFC-A or RFC-S	Pr <b>0.04.011</b> = Speed control mode (0)
			Open-loop or Regen	Return 'Drive state conflict' error (0x10)
	3	Torque Control	Open-loop or RFC-A or RFC-S	Pr <b>0.04.011</b> = Torque control mode (1)
			Regen	Return 'Drive state conflict' error (0x10)

**NOTE**

Pr **0.11.031** will never be changed by setting the DriveMode attribute. An error (0x10) will be generated if the requested DriveMode value does not correspond to the current DriveType operating mode.

**SpeedActual**

<b>Name:</b>	<b>SpeedActual</b>		
<b>Class</b>	0x2A	<b>Default</b>	N/A
<b>Instance</b>	0x01	<b>Data Type</b>	USINT
<b>Attribute</b>	0x07	<b>Access</b>	Get

Returns the actual speed of the motor in RPM. The source of the motor speed depends on the operating mode of the drive.

- Get Pr **0.05.004** (Open Loop).
- Get Pr **0.03.002** (RFC-A or RFC-S).

**SpeedRef**

<b>Name:</b>	<b>SpeedRef</b>		
<b>Class</b>	0x2A	<b>Default</b>	N/A
<b>Instance</b>	0x01	<b>Data Type</b>	USINT
<b>Attribute</b>	0x08	<b>Access</b>	Get/Set

Sets or returns the speed reference in RPM.

- RFC-A or RFC-S**  
Get/Set SpeedRef = Pr **0.01.021** (Scaled to 0 decimal places).
- Open loop**  
Get SpeedRef = (Pr **0.01.021** \* 60) / Pole Pairs (Scaled to 0 decimal places).  
Set Pr **0.01.021** = (SpeedRef \* Pole Pairs) / 60 (Scaled to 0 decimal places).

**TorqueActual**

<b>Name:</b>	<b>TorqueActual</b>		
<b>Class</b>	0x2A	<b>Default</b>	N/A
<b>Instance</b>	0x01	<b>Data Type</b>	USINT
<b>Attribute</b>	0x0B	<b>Access</b>	Get

Returns the actual load on the motor as a percentage of the rated motor load. This attribute has 1 decimal place precision, a value of 1000 represents 100.0 % load.

Get Pr **0.04.020** (Scaled to 1 decimal place).

**TorqueRef**

<b>Name:</b>			
<b>Class</b>	0x2A	<b>Default</b>	N/A
<b>Instance</b>	0x01	<b>Data Type</b>	USINT
<b>Attribute</b>	0x0C	<b>Access</b>	Get/Set

Sets the load (torque) reference as % of rated motor load (torque). This attribute has 1 decimal place precision, so a value of 1000 represents 100.0 % load.

- Set Pr **0.04.008** = TorqueRef / 10 (Scaled to 1 decimal place).
- Get TorqueRef = Pr **0.04.008** \* 10 (Scaled to 1 decimal place).

**RefFromNet**

<b>Name:</b>	<b>RefFromNet</b>		
<b>Class</b>	0x2A	<b>Default</b>	
<b>Instance</b>	0x01	<b>Data Type</b>	USINT
<b>Attribute</b>	0x1D	<b>Access</b>	Get

Indicates the source of the speed reference.

- TRUE if Pr **0.01.049** = 3 and Pr **0.01.050** = 1.
- FALSE otherwise.

**9.4.21 Control Techniques objects**

The Control Techniques objects (classes 0x64 to 0x69) allow access to all drive and option module parameters. The class instance number is used to reference the drive or option module menu number (except menu 0) and the class attribute number references the parameter within that menu.

For example, the drive parameter *Percentage Load* (**0.04.020**) would be accessed as class 0x64, instance 0x04 and attribute 0x14.

An instance value of 0 is invalid therefore to allow access to menu 0 parameters, the instance value 200 (0xC8) must be used.

The number of instances and therefore the number of menus for each class depends on the destination device. If the drive is the destination then the number of menus will depend on the drive operating mode. If the destination is one of the option slots (or onboard Ethernet interface) then the number of menus depends on the type of option module fitted (or the onboard Ethernet interface).

Six individual classes are provided, the following table shows the classes used when accessing the drive or option module parameters.

**Table 9-35 Control Techniques object classes**

Class Code		Name	Description
Dec	Hex (0x)		
100	64	CT Group	Provides access to all drive parameters
101	65	CT This Slot	Provides access to the connected Ethernet interface parameters
102	66	CT Slot 1	Provides access to the option module in slot 1 parameters
103	67	CT Slot 2	Provides access to the option module in slot 2 parameters
104	68	CT Slot 3	Provides access to the option module in slot 3 parameters (Factory fit Ethernet)

## 9.5 Profinet IO specification

### 9.5.1 What is PROFINET?

PROFINET is an Ethernet based industrial network protocol adapting Ethernet hardware and protocols to the real time needs of industrial automation. Profinet enables distributed IO control from a PLC.

### 9.5.2 Features / Specification

- Dual 100 BASE-TX RJ45 connectors with support for shielded twisted pair, full-duplex 100 M bps connectivity with auto crossover correction
- Both RJ45 ports operate in full duplex mode as a network switch
- PROFINET Real Time class RT\_Class\_1 and conformance class A
- Cycle times from 1 ms to 512 ms specified during configuration
- Automatic device replacement using the LLDP protocols
- LED indication of network port activity
- Up to 64 cyclic IO module slots (maximum 32 inputs and 32 outputs configured by network configuration tool and GSDML file)
- Identification and Maintenance functions I&M0 to I&M4 supported

#### NOTE

When referring to the cyclic data, the terms input and output are with respect to the PROFINET IO controller (PLC).

#### NOTE

The terms 'network controller' and 'PLC' are mutually used in this manual to refer to the PROFINET network controller. This is generally a PLC with a PROFINET interface and possibly a programming interface to connect to the programming device or PC. However this interface is not necessary, as the PROFINET interface can be used to program the PLC.

### 9.5.3 GSDML Files

A GSDML (General Station Description Markup Language) file is required to describe the drive interface to a PROFINET controller or PLC. This is an XML file, the structure of which is specified by the PROFIBUS INTERNATIONAL organization ([www.profibus.org](http://www.profibus.org)).

The GSDML file is used in conjunction with the network configuration software to configure the Profinet interface for cyclic data exchange. Many commonly used drive parameters are available as direct mapping 'modules' to be added to the cyclic data 'slots'.

Non-specific 'Flexible modules' are also provided so that the user can allocate a parameter within the drive (or option module), that is not directly available as a specific 'module'. These options will be available from a drop-down selection list within the 'Parameters' tab of the 'module' properties.

#### NOTE

For further information regarding the use of the GSDML file please refer to the PLC documentation.

### 9.5.4 Network topology

The Ethernet interface has two Ethernet ports with integrated switches to allow the use of line networks. However, when using line networks, a break in the connection (for example when replacing a device) will cause all devices downstream from the failure to also stop communicating with the controller.

Other Ethernet network topologies can be used but care must be taken to ensure that the system still operates within the constraints specified by the designer.

Generally a star or tree network structure using switches gives improved availability in the event of a device failure or replacement.

Although the Profinet protocol does support all major topologies, line networks are normally used for practical or financial reasons, other topologies (e.g. star) may not be suitable for real time communications due to their inherent use of switches or other network equipment.

Any network devices used, such as switches, must be capable of real time communication. Standard office grade equipment is not normally suitable and should not be used in an industrial environment.

#### NOTE

For the device replacement feature to work, the physical network topology must be configured in the controller. For further information please refer to the controller or network configuration software documentation.

### 9.5.5 Configuring the PROFINET IO communications

No module parameters need to be configured by the user in order to achieve PROFINET cyclic communications. All the necessary configuration is undertaken by the network controller or PLC during the start-up sequence, and after the network configuration is programmed into the network controller or PLC.

It must be noted that when configuring the cyclic data modules, if a module is configured but the associated drive parameter does not actually exist in the drive, then the PLC will not start up correctly and will indicate a configuration fault.

Parameters of slot option module menus can also be configured for cyclic data communication via correctly configured 'Flexible Modules'. The source of the associated parameter can be set to drive or any possible slot within the 'Flexible Module' parameter properties.

### 9.5.6 Setting the Profinet device name

Each Profinet device must have it's own unique device name assigned during network configuration. Device names are used by the controller to communicate with the device for real time messages and alarms. Without a device name the device will not enter data exchange with the controller.

The actual device name is not important to the Profinet system itself, however, a suitable name should be chosen so that it is easily recognised on the network and identifies the location and function of the device.

A typical device name may contain up to four labels, each label is separated by a dot (.) and may be up to 63 characters in length.

The following rules must be observed when choosing the device name:

- Maximum length of 127 characters
- Characters must be lower case letters, numbers, dashes (-) or dots (.)
- The device name must start with a letter and end with either a letter or number
- The device name must not be in the format n.n.n.n (where n is a number from 0 to 999)
- The device name must not begin with the character sequence 'port-xyz' (where x, y and z are numbers from 0 to 9).

A typical example of a device name may be:

**motor-1.conveyor-2.line-3.ct-4**

The default device name is specified in the GSDML file under the section 'DNS\_CompatibleName'.

### 9.5.7 Profinet transmission cycle (send cycle)

The Profinet transmission cycle is the time required to update all the devices on the Profinet network, the duration of the transmission cycle is determined by the Profinet device with the slowest update rate.

The transmission cycle can be split into a number of phases, where each phase contains one or more devices with similar update rates, the duration of each phase will be equal to the fastest update rate.

#### Base clock

The base clock is the minimum time unit used and is equal to 31.25 µs.

#### Send clock factor

The send clock factor determines the duration of each phase and is the number of base clock periods within each phase.

The following table illustrates the relationship between the supported send clock values and the phase duration.

Send Clock Factor	Phase Duration (ms)
32	1
64	2
128	4

#### Phase duration

The duration (or length) of each phase is determined by the formula:

$$\text{Phase duration} = \text{Send clock factor} \times \text{Base clock.}$$

#### Reduction ratio

The reduction ratio acts as a multiplier of the minimum update time (or phase duration) and is determined for each device by the formula:

$$\text{Reduction ratio} = \text{Device update time} / \text{Phase duration}$$

#### Number of phases

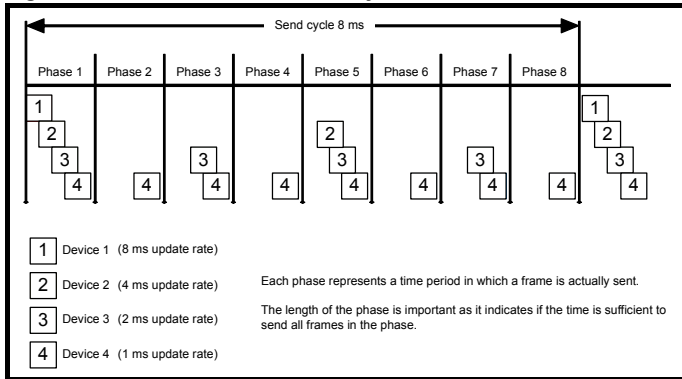
The number of phases is determined by the formula:

$$\text{Number of phases} = \text{Send cycle} / \text{fastest update rate.}$$

#### Example:

In the following example, a system uses four devices, device 1 has an update rate of 8 ms, device 2 has an update rate of 4 ms, device 3 has an update rate of 2 ms and device 4 has an update rate of 1 ms.

**Figure 9-5 Profinet transmission cycle**



The Profinet transmission cycle is effectively the slowest update rate (8 ms in this example), and the phase duration is effectively the quickest update rate (1 ms in this example).

$$\begin{aligned} \text{Phase duration} &= \text{Send clock factor} \times \text{Base clock} \\ &= 32 \times 31.25 \mu\text{s} = 1 \text{ ms} \end{aligned}$$

$$\text{Reduction ratio} = \text{Device update time} / \text{Phase duration}$$

$$\text{Reduction ratio}_{(\text{device1})} = 8 \text{ ms} / 1 \text{ ms} = 8$$

$$\text{Reduction ratio}_{(\text{device2})} = 4 \text{ ms} / 1 \text{ ms} = 4$$

$$\text{Reduction ratio}_{(\text{device3})} = 2 \text{ ms} / 1 \text{ ms} = 2$$

$$\text{Reduction ratio}_{(\text{device4})} = 1 \text{ ms} / 1 \text{ ms} = 1$$

$$\begin{aligned} \text{Number of phases} &= \text{Send cycle} / \text{fastest update rate} \\ &= 8 \text{ ms} / 1 \text{ ms} = 8 \end{aligned}$$

### 9.5.8 Update rates

In contrast to some other fieldbus networks, Profinet devices can be configured with different update rates, these rates are specified in the device GSDML file. The Profinet interface on the Digitax HD M750 supports update rates of 1, 2, 4, 8, 16, 32, 64, 128, 256 and 512 ms.

It is recommended that to avoid the possibility of overloading any sections of the Profinet network, the slowest update rate necessary is used.

The update rate can be configured in one of three ways:

- **Automatic** – the update rate selected is the time calculated by the I/O system that can be reliably achieved, based on the configuration.
- **Fixed update time** – the update rate is selected by the user from a list of supported rates specified in the GSDML file
- **Fixed factor** – the update rate is selected by the user from a list of supported rates specified in the GSDML file

#### NOTE

This information only applies to the Siemens I/O configuration system (TIA Portal/SIMATIC STEP7), other I/O configuration systems may provide different configuration options.

### 9.5.9 Link Layer Discovery Protocol (LLDP)

LLDP is a manufacturer independent layer 2 protocol defined in accordance with the IEEE802.1AB standard.

During start-up and at regular intervals, LLDP messages are used to transfer device information between neighbouring devices. This information includes the device name and connection port numbers. LLDP messages use a special multicast destination MAC address that the IEEE802.1D compliant bridges and switches should not forward.

If all devices in a network support LLDP messages then an accurate network topology view can be presented in the I/O system configuration / diagnostic tool.

### 9.5.10 Discovery and Configuration Protocol (DCP)

The Discovery and Configuration Protocol is used in the event of a device replacement to automatically configure the new device. All the necessary configuration is done by an appropriate neighbouring device when the new device is detected.

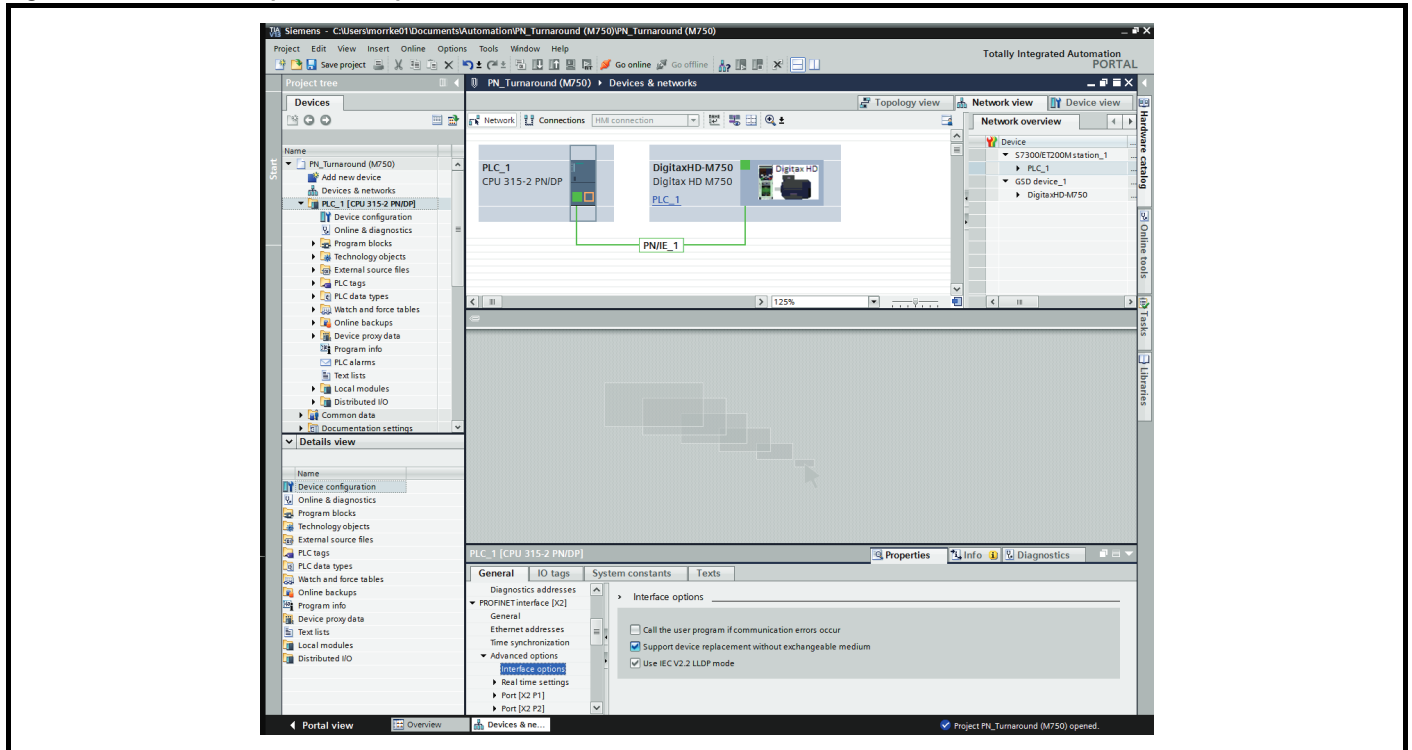
In order to use the network discovery and configuration protocol, the PLC must be correctly configured and programmed with the physical network topology, the following information is intended as a guide only, for more specific information (in particular for other types of PLC's), then please consult the PLC documentation.

#### NOTE

Although the Siemens PLC is mentioned in this manual, Control Techniques does not recommend or endorse any particular PLC or controller manufacturer.

The following information relates to the Siemens S7-1215C PLC. The PLC must be configured to support device replacement, this is an option in the properties of the PROFINET port. In the device configuration screen of the TIA PORTAL application, open the properties of the PLC PROFINET port, click 'Interface options' under 'Advanced options' as shown in Figure 9-6. Ensure the option 'Support device replacement without exchangeable medium' is selected.

**Figure 9-6 PLC device replacement option**



The network topology must now be configured. From the hardware configuration screen, select the port, right click it and select 'PROFINET IO Topology...', the topology editor will be displayed, select the 'Graphic view' tab and using 'drag and drop', connect the relevant device ports together to match the physical network wiring. The program must then be compiled and downloaded to the PLC in the normal manner. Once the PLC has been configured, if a device is replaced then the new device will be automatically configured with the original device's properties, including the device name and IP address.

**NOTE**

For the discovery protocol to work, the replacement device must not have a device name programmed, i.e. it must be blank or unused. If a device name exists in the module and that name is different to the device name set in the network configuration then the PLC will indicate a configuration error and will not enter data exchange with it.

**9.5.11 Identification and Maintenance (I&M)**

Identification and Maintenance (I&M) functions can be used to read and change various information about devices, such as manufacturer, ordering information, serial number, etc. This information can be used to assist the user in tracking the drive's life cycle through commissioning/start-up, parameterization, diagnosis, repair, etc. The Ethernet interface supports I&M0 to I&M4 inclusively; I&M0 is mandatory for all PROFINET devices, I&M1 to I&M4 are optional. Each I&M function returns specific information about the device and is explained in the following tables.

**I&M0**

**Table 9-36 I&M0 Description**

Attribute	Value (Read only)
Manufacturer ID	0x0160
Order ID	DigitaxHD M750
Serial number	(Pr 17.00.005 x 1,000,000,000 + Pr 17.00.004)
Hardware revision	(Pr 17.00.003)
Software revision	(Pr 17.00.002)
Revision counter	(Pr 17.24.006)
Profile ID	(as read)
Profile specific type	(as read)
I&M version	(as read)
I&M supported	(as read)

**Manufacturer ID:** 2-byte unsigned hexadecimal number assigned by the PROFIBUS business office and specified in the GSDML file. For Control Techniques this value is 0x0160.

**Order ID:** 20-byte string to identify the device. This value is specified in the GSDML file. For the Ethernet interface this value is 'DigitaxHD M750'.

**Serial number:** 16 character string indicating the module serial number. This value is read from Pr 3.00.004 and Pr 3.00.005 of the Ethernet interface.

**Hardware revision:** 2-byte unsigned hexadecimal number indicating the hardware revision of the Ethernet interface. This value is read from Pr 3.00.003 of the Ethernet interface.

**Software revision:** 4-byte value consisting of a single character 'V' and 3 unsigned 8-bit decimal numbers indicating the software revision of the Ethernet interface. This value is taken from Pr 3.00.002 of the Ethernet interface.

**Revision counter:** 2-byte unsigned decimal number. This value will increment by one for each of the following conditions:  
 > Drive parameter save  
 > Drive parameter default  
 > Drive mode change

Will wrap back to 1 after a value of 65535.

**Profile ID:** 2-byte unsigned hexadecimal number indicating the application profile. Devices not following any particular profile use the generic profile value 0xF600.

**Profile specific type:** 2-byte unsigned hexadecimal number indicating the application profile specific type. This value is not applicable to devices using the generic profile and in these instances this value will be zero.

**I&M version:** 2 unsigned 8-bit numbers indicating the version of the implemented I&M functions.

**I&M supported:** 2-byte unsigned number indicating the availability of the implemented I&M functions as shown in Table 9-37.

**Table 9-37 Supported I&M bit descriptions**

Bit	Value	Description
0		Profile specific I&M
1	0	I&M1 Not supported
	1	I&M1 Supported
2	0	I&M2 Not supported
	1	I&M2 Supported
3	0	I&M3 Not supported
	1	I&M3 Supported
4	0	I&M4 Not supported
	1	I&M4 Supported
5 to 15		Reserved

#### I&M1

**Table 9-38 I&M1 Description**

Attribute	Value (Read/Write)
Drive function (32 bytes)	(User defined)
Drive location (22 bytes)	(User defined)

**Drive function:** 32-byte string indicating the drive function.

**Drive location:** 22-byte string indicating the drive location.

#### I&M2

**Table 9-39 I&M2 Description**

Attribute	Value (Read/Write)
Installation date	(User defined)

**Installation date:** 16-byte string indicating the installation or commissioning date of the device. The installation date is in the format DD/MM/YYYY.

#### I&M3

**Table 9-40 I&M3 Description**

Attribute	Value (Read/Write)
Descriptor (54 bytes)	(User defined)

**Descriptor:** 54-byte string used to store additional information on the location, function or maintenance status of the device.

#### I&M4

**Table 9-41 I&M4 Description**

Attribute	Value (Read/Write)
Signature (54 bytes)	(User defined)

**Signature:** 54-byte octet string used to allow parameterization tools to store a security code as a reference for a particular parameterization session and audit trail tools to retrieve the code for integrity checks.

#### NOTE

All unused bytes of the I&M functions will be set to 0x20 (space).

### 9.5.12 IP Address configuration

When a Digitax HD M750 is fitted with a KI-Compact Display the two rotary dials on the display allow the final octet (host component) of the IP address to be configured when set to a non zero value and a 24 bit subnet (255.255.255.0), see Table 9-42.

**Table 9-42 Address components**

Address class	IP Address	Subnet component	Host
C	w.x.y.z	w.x.y	z

The final octet of the IP address configured using the KI-Compact Display is an 8 bit value (decimal 1 to 255). The most significant nibble is

set by adjusting the top dial and the least significant nibble is set by the bottom dial (see Figure 5-1 *KI-Compact Display* on page 31).

Dial settings and equivalent decimal values are shown in Table 9-43.

**Table 9-43 Dial settings and equivalent decimal value**

Most significant nibble		Least significant nibble	
Dial setting	Decimal value	Dial setting	Decimal value
1	16	1	1
2	32	2	2
3	48	3	3
4	64	4	4
5	80	5	5
6	96	6	6
7	112	7	7
8	128	8	8
9	144	9	9
A	160	A	10
B	176	B	11
C	192	C	12
D	208	D	13
E	224	E	14
F	240	F	15

The final octet of the IP address will be set to the sum of the most significant nibble and the least significant nibble (in decimal).

As the dials are adjusted each setting is shown on the display. Once the dials are set to the desired configurations the display will confirm the dial settings in hexadecimal followed by the final octet of the IP address in decimal, dial settings and IP address settings are separated with a hyphen (-).

Once the desired dial configurations have been set, the KI-Compact Display will transfer the value to Pr **11.017 Keypad defined node address** and if the value is not zero Pr **3.00.010 Active IP Address** is updated with the chosen address.

The drive will use Pr **3.00.006 IP Address** as the source for the IP address when the dial setting is a zero value. Any non zero rotary dial setting will result in Pr **3.00.006 IP Address** being ignored and Pr **3.00.010 Active IP Address** becoming the chosen address.

#### Example:

To set a node address of 55 via the display, with reference to Table 9-43, set the most significant dial to 3 (decimal 48) and the least significant dial to 7 (decimal 7).

#### NOTE

The IP address setting can be configured from the rotary dials of the KI-Compact Display with no power applied to the drive (with the exception of a zero value setting). Non zero configured settings will be transferred to the drive on the next power up.

#### NOTE

The KI-Compact Display can be installed/removed while the drive is powered. A delay of 10 seconds should be maintained following power up or following a node address dial adjustment before the KI-Compact Display can be removed from the drive, to ensure correct transfer of IP address configuration data.

#### NOTE

The rotary dials have no effect when the Profinet interface is enabled (Pr **3.02.018** = ProfiNet).

# 10 SD Card Operation

## 10.1 Introduction

The Non-Volatile Media Card feature enables simple configuration of parameters, parameter back-up, storing / reading PLC programs and drive copying using an SD card storing / reading PLC programs.

The SD Card can be used for:

- Parameter copying between drives
- Saving drive parameter sets
- Saving an onboard user program

The SC Card slot is located at the middle of the module, adjacent to the drive compact display (if installed) on the right-hand side.

Ensure the SD Card is inserted with the contacts facing the left-hand side of the drive.

The drive only communicates with the SD Card when commanded to read or write, meaning the card may be "hot swapped".

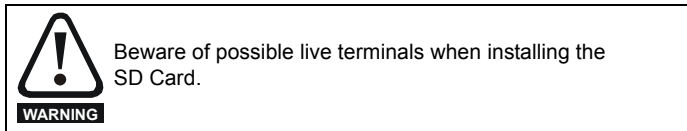
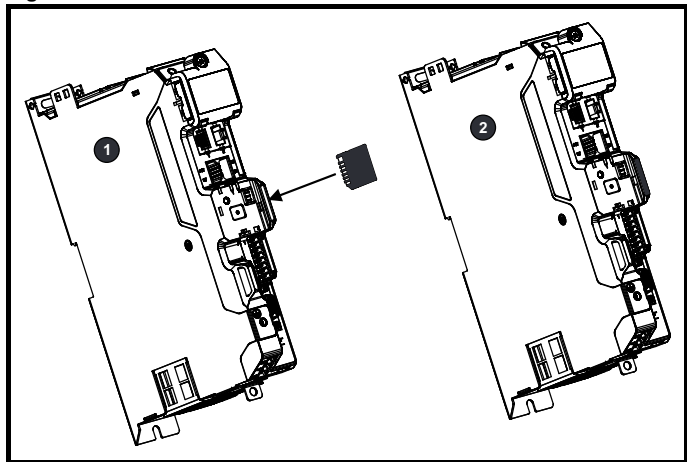


Figure 10-1 Installation of the SD Card



1. Installing the SD Card
2. SD Card installed

## 10.2 SD Card support

The SD Card can be used to store drive parameter sets and / or PLC programs set from the Digitax HD in data blocks 001 to 499 on the card.

**NOTE**

If the read only flag is set then only codes 6yyy or 9777 are effective.

Figure 10-2 Basic SD Card operation

**Pr 00.030 = Read + [Read Icon]**  
Drive reads all parameters from the SD Card

**Pr 00.030 = Program + [Program Icon]**  
Programs all drive parameters to the SD Card  
**NOTE** Overwrites any data already in data block 1

**Pr 00.030 = Auto + [Auto Icon]**  
Auto Save  
Drive automatically writes to the SD Card when a parameter save is performed

**Pr 00.030 = Boot + [Boot Icon]**  
Boot  
Auto Save  
Drive boots from the SD Card on power up and automatically writes to the SD Card when a parameter save is performed

The whole card may be protected from writing or erasing by setting the read-only flag as detailed section 10.3.9 9888 / 9777 - *Setting and clearing the SD Card read only flag* on page 119.

The card should not be removed during data transfer, as the drive will produce a trip. If this occurs then either the transfer should be reattempted or in the case of a card to drive transfer, default parameters should be loaded.

## 10.3 Transferring data

Data transfer, erasing and protecting the information is performed by entering a code in Pr **mm.000** and then resetting the drive as shown in Table 10-1.

**Table 10-1 SD card codes**

Code	Operation	SD card
2001	Transfer the drive parameters to parameter file 001 and sets the block as bootable. This will include the parameters from attached option modules.	✓
4yyy	Transfer the drive parameters to parameter file yyy. This will include the parameters from attached option modules.	✓
5yyy	Transfer the onboard user program to onboard user program file yyy.	✓
6yyy	Load the drive parameters from parameter file yyy or the onboard user program from onboard user program file yyy.	✓
7yyy	Erase file yyy.	✓
8yyy	Compare the data in the drive with file yyy. If the files are the same then Pr <b>mm.000</b> ( <b>mm.000</b> ) is simply reset to 0 when the compare is complete. If the files are different a 'Card Compare' trip is initiated. All other SD card trips also apply.	✓
9555	Clear the warning suppression flag	✓
9666	Set the warning suppression flag	✓
9777	Clear the read-only flag	✓
9888	Set the read-only flag	✓
9999	Erase and format the SD card	

Where yyy indicates the block number 001 to 999.

### NOTE

If the read only flag is set then only codes 6yyy or 9777 are effective.

### 10.3.1 Writing to the SD Card

#### 4yyy - Writes defaults differences to the SD Card

The data block only contains the parameter differences from the last time default settings were loaded.

All parameters except those with the NC (Not copied) coding bit set are transferred to the SD Card. In addition to these parameters all menu 20 parameters (except Pr **20.000**), can be transferred to the SD Card.

#### Writing a parameter set to the SD Card (Pr **00.030** = Program (2))

Setting Pr **00.030** to Program (2) and resetting the drive will save the parameters to the SD Card, i.e. this is equivalent to writing 4001 to Pr **mm.000**. All SD Card trips apply except 'Card Change'. If the data block already exists it is automatically overwritten. When the action is complete this parameter is automatically reset to None (0).

### 10.3.2 Reading from the SD Card

#### 6yyy - Reading from SD Card

When the data is transferred back to the drive, using 6yyy in Pr **mm.000**, it is transferred to the drive RAM and the EEPROM. A parameter save is not required to retain the data after-power down. Set up data for any option modules installed stored on the card are transferred to the drive. If the option modules installed are different between source and destination drives, the menus for the option module slots where the option module categories are different are not updated from the card and will contain their default values after the copying action. The drive will produce a 'Card Option' trip if the option module installed to the source and the destination drives are different or are in different slots. If the data is being transferred to the drive with different voltage or current rating a 'Card Rating' trip will occur.

The following drive rating dependant parameters (RA coding bit set) will not be transferred to the destination drive by a SD Card when the voltage rating of the destination drive is different from the source drive and the file is a parameter file.

However, drive rating dependent parameters will be transferred if only the current rating is different. If drive rating dependant parameters are not transferred to the destination drive they will contain their default values.

Pr **02.008** *Standard Ramp Voltage*

Pr **04.005** to Pr **04.007** and Pr **21.027** to Pr **21.029** *Motoring Current Limits*

Pr **04.024**, *User Current Maximum Scaling*

Pr **05.007**, Pr **21.007** *Rated Current*

Pr **05.009**, Pr **21.009** *Rated Voltage*

Pr **05.010**, Pr **21.010** *Rated Power Factor*

Pr **05.017**, Pr **21.012** *Stator Resistance*

Pr **05.018** *Maximum Switching Frequency*

Pr **05.024**, Pr **21.014** *Transient Inductance*

Pr **05.025**, Pr **21.024** *Stator Inductance*

Pr **06.006** *Injection Braking Level*

Pr **06.048** *Supply Loss Detection Level*

Pr **06.065** *Standard Under Voltage Threshold*

Pr **06.066** *Low Under Voltage Threshold*

Pr **06.073** *Braking IGBT Lower Threshold*

Pr **06.074** *Braking IGBT Upper Threshold*

Pr **06.075** *Low Voltage Braking IGBT Threshold*

#### Reading a parameter set from the SD Card (Pr **00.030** = Read (1))

Setting Pr **00.030** to Read (1) and resetting the drive will transfer the parameters from the card into the drive parameter set and the drive EEPROM, i.e. this is equivalent to writing 6001 to Pr **mm.000**.

All SD Card trips apply. Once the parameters are successfully copied this parameter is automatically reset to None (0). Parameters are saved to the drive EEPROM after this action is complete.

### 10.3.3 Auto saving parameter changes (Pr **00.030** = Auto (3))

This setting causes the drive to automatically save any changes made to menu 0 parameters on the drive to the SD Card. The latest menu 0 parameter set in the drive is therefore always backed up on the SD Card. Changing Pr **00.030** to Auto (3) and resetting the drive will immediately save the complete parameter set from the drive to the card, i.e. all parameters except parameters with the NC coding bit set. Once the whole parameter set is stored only the individual modified menu 0 parameter setting is updated.

Advanced parameter changes are only saved to the SD Card when Pr **mm.000** is set to 'Save Parameters' or a 1001 and the drive reset.

All SD Card trips apply, except 'Card Change'. If the data block already contains information it is automatically overwritten.

If the card is removed when Pr **00.030** is set to 3 Pr **00.030** is then automatically set to None (0).

When a new SD Card is installed Pr **00.030** must be set back to Auto (3) by the user and the drive reset so the complete parameter set is rewritten to the new SD Card if auto mode is still required.

When Pr **00.030** is set to Auto (3) and the parameters in the drive are saved, the SD Card is also updated, and therefore the SD Card becomes a copy of the drives stored configuration.

At power up, if Pr **00.030** is set to Auto (3), the drive will save the complete parameter set to the SD Card. The drive will display 'Card Write' during this operation. This is done to ensure that if a user puts a new SD Card in during power down the new SD Card will have the correct data.

**NOTE**

When Pr **00.030** is set to Auto (3) the setting of Pr **00.030** itself is saved to the drive EEPROM but not the SD Card.

### 10.3.4 Booting up from the SD Card on every power up (Pr **00.030** = Boot (4))

When Pr **00.030** is set to Boot (4) the drive operates the same as Auto mode except when the drive is powered-up. The parameters on the SD Card will be automatically transferred to the drive at power up if the following are true:

- A card is inserted in the drive
- Parameter data block 1 exists on the card
- The data in block 1 is type 1 to 4 (as defined in Pr **11.038**)
- Pr **00.030** on the card set to Boot (4)

The drive will display 'Booting Parameters' during this operation. If the drive mode is different from that on the card, the drive gives a 'Card Drive Mode' trip and the data is not transferred.

If 'Boot' mode is stored on the copying SD Card this makes the copying SD Card the master device. This provides a very fast and efficient way of re-programming a number of drives.

**NOTE**

'Boot' mode is saved to the card, but when the card is read, the value of Pr **00.030** is not transferred to the drive.

### 10.3.5 Booting up from the SD Card on every power up (Pr **mm.000** = 2001)

It is possible to create a bootable parameter data block by setting Pr **mm.000** to 2001 and initiating a drive reset. This data block is created in one operation and is not updated when further parameter changes are made.

Setting Pr **mm.000** to 2001 will overwrite the data block 1 on the card if it already exists.

### 10.3.6 8yyy - Comparing the drive full parameter set with the SD Card values

Setting 8yyy in Pr **mm.000**, will compare the SD Card file with the data in the drive. If the compare is successful Pr **mm.000** is simply set to 0. If the compare fails a 'Card Compare' trip is initiated.

### 10.3.7 7yyy - Erasing data from the SD Card values

Data can be erased from the SD Card one block at a time.

- Setting 7yyy in Pr **mm.000** will erase SD Card data block yyy.

### 10.3.8 9666 / 9555 - Setting and clearing the SD Card warning suppression flag

If the option modules installed to the source and destination drive are different or are in different slots the drive will produce a 'Card Option' trip.

If the data is being transferred to a drive of a different voltage or current rating a 'Card Rating' trip will occur. It is possible to suppress these trips by setting the warning suppression flag. If this flag is set the drive will not trip if the option module(s) or drive ratings are different between the source and destination drives. The options module or rating dependent parameters will not be transferred.

- Setting 9666 in Pr **mm.000** will set the warning suppression flag
- Setting 9555 in Pr **mm.000** will clear the warning suppression flag

### 10.3.9 9888 / 9777 - Setting and clearing the SD Card read only flag

The SD Card may be protected from writing or erasing by setting the read only flag. If an attempt is made to write or erase a data block when the read only flag is set, a 'Card Read Only' trip is initiated. When the read only flag is set only codes 6yyy or 9777 are eff.

- Setting 9888 in Pr **mm.000** will set the read only flag
- Setting 9777 in Pr **mm.000** will clear the read only flag

### 10.4 Data block header information

Each data block stored on an SD Card has header information detailing the following:

- NV Media Card File Number (11.037)
- NV Media Card File Type (11.038)
- NV Media Card File Version (11.039)
- NV Media Card File Checksum (11.040)

The header information for each data block which has been used can be viewed in Pr **11.038** to Pr **11.040** by increasing or decreasing the data block number set in Pr **11.037**. If there is no data on the card Pr **11.037** can only have a value of 0.

### 10.5 NV Media / SD Card parameters

**Table 10-2 Key to parameter table coding**

RW	Read / Write	ND	No default value
RO	Read only	NC	Not copied
Num	Number parameter	PT	Protected parameter
Bit	Bit parameter	RA	Rating dependant
Txt	Text string	US	User save
Bin	Binary parameter	PS	Power-down save
FI	Filtered	DE	Destination

11.036 {00.029}		NV Media Card File Previously Loaded			
RO	Num			NC	PT
OL					
RFC-A	⇕	0 to 999	⇒	0	
RFC-S					

This parameter shows the number of the data block last transferred from an SD Card to the drive. If defaults are subsequently reloaded this parameter is set to 0.

11.037		NV Media Card File Number			
RW	Num				
OL					
RFC-A	⇕	0 to 999	⇒	0	
RFC-S					

This parameter is used to select a data block file by its file identification number and can only be changed to values that correspond to files that are recognised by the drive on the SD card or a value of 0.

When NV Media Card File Number (Pr **11.037**) corresponds to the number of a data block file, Pr **11.038**, Pr **11.039** and Pr **11.040** are populated with data relating to that specific file number.

11.038		NV Media Card File Type			
RO	Txt		ND	NC	PT
OL					
RFC-A	⇕	None (0), Open-loop (1), RFC-A (2), RFC-S (3), Regen (4), User Prog (5), Option App (6)	⇒		
RFC-S					

Displays the type/mode of the data block selected with Pr 11.037.

Pr 11.038	String	Type / mode
0	None	No file selected
1	Open-loop	Open-loop mode parameter file
2	RFC-A	RFC-A mode parameter file
3	RFC-S	RFC-S mode parameter file
4	Regen	Regen mode parameter file
5	User Prog	Onboard user program file
6	Option App	Option module application file

11.073		NV Media Card Type						
RO	Txt				ND	NC	PT	
OL								
RFC-A	⇕	None (0), SD Card (1)			⇒			
RFC-S								

This will display the type of media card inserted; it will contain one of the following values:

"None" (0) - No SD Card has been inserted.

"SD Card" (1) - A FAT formatted SD card has been inserted.

11.039		NV Media Card File Version						
RO	Num				ND	NC	PT	
OL								
RFC-A	⇕	0 to 9999			⇒			
RFC-S								

Displays the version number of the file selected in Pr 11.037.

11.075		NV Media Card Read-only Flag						
RO	Bit				ND	NC	PT	
OL								
RFC-A	⇕	Off (0) or On (1)			⇒			
RFC-S								

NV Media Card Read-only Flag (11.075) shows the state of the read-only flag for the currently installed card.

11.040		NV Media Card File Checksum						
RO	Num				ND	NC	PT	
OL								
RFC-A	⇕	-2147483648 to 2147483647			⇒			
RFC-S								

Displays the checksum of the data block selected in Pr 11.037.

11.076		NV Media Card Warning Suppression Flag						
RO	Bit				ND	NC	PT	
OL								
RFC-A	⇕	Off (0) or On (1)			⇒			
RFC-S								

NV Media Card Warning Suppression Flag (11.076) shows the state of the warning flag for the currently installed card.

11.042 {00.030}		Parameter Cloning						
RW	Txt				NC		US*	
OL								
RFC-A	⇕	None (0), Read (1), Program (2), Auto (3), Boot (4)			⇒	None (0)		
RFC-S								

\* Only a value of 3 or 4 in this parameter is saved.

#### NOTE

If Pr 11.042 is equal to 1 or 2, this value is not transferred to the drive or saved to the EEPROM. If Pr 11.042 is set to 3 or 4 the value is saved to the EEPROM

None (0) = Inactive

Read (1) = Read parameter set from the SD Card

Program (2) = Program a parameter set to the SD Card

Auto (3) = Auto save

Boot (4) = Boot mode

11.077		NV Media Card File Required Version						
RW	Num				ND	NC	PT	
OL								
RFC-A	⇕	0 to 9999			⇒			
RFC-S								

The value of NV Media Card File Required Version (11.077) is used as the version number for a file when it is created on an SD Card. NV Media Card File Required Version (11.077) is reset to 0 when the file is created or the transfer fails.

## 10.6 SD Card trips

After an attempt to read, write or erase data from an SD card, a trip is initiated if there has been a problem with the command.

See Chapter 13 *Diagnostics* on page 217 for more information on SD Card trips.

11.072		NV Media Card Create Special File						
RW	Num				NC			
OL								
RFC-A	⇕	0 to 1			⇒	0		
RFC-S								

If NV Media Card Create Special File (11.072) = 1 when a parameter file is transferred to an SD card the file is created as a macro file. NV Media Card Create Special File (11.072) is reset to 0 after the file is created or the transfer fails.

# 11 Onboard PLC

## 11.1 Onboard PLC and Machine Control Studio

The drive has the ability to store and execute a 16 kB Onboard PLC user program without the need for additional hardware in the form of an option module.

Machine Control Studio is an IEC61131-3 development environment designed for use with Digitax HD and compatible application modules.

All of the programming languages defined in the IEC standard IEC 61131-3 are supported in the Machine Control Studio development environment.

- ST (Structured text)
- LD (Ladder diagram)
- FBD (Function block diagram)
- IL (Instruction list)
- SFC (Sequential function chart)
- CFC (Continuous Function Chart). CFC is an extension to the standard IEC programming languages

Machine Control Studio provides a complete environment for the development of user programs. Programs can be created, compiled and downloaded to a Digitax HD for execution, via the communications port on the front of the drive. The run-time operation of the compiled program on the target can also be monitored using Machine Control Studio and facilities are provided to interact with the program on the target by setting new values for target variables and parameters.

The Onboard PLC and Machine Control Studio form the first level of functionality in a range of programmable options for Digitax HD.

Machine Control Studio can be downloaded from [www.drive-setup.com](http://www.drive-setup.com).

See the Machine Control Studio help file for more information regarding using Machine Control Studio, creating user programs and downloading user programs to the drive.

## 11.2 Benefits

The combination of the Onboard PLC and Machine Control Studio, means that the drive can replace nano and some micro PLCs in many applications. Machine Control Studio benefits from access to function and function block libraries as well as those from third parties. Functions and function blocks available as standard in Machine Control Studio include, but not limited to, the following:

- Arithmetic blocks
- Comparison blocks
- Timers
- Counters
- Multiplexers
- Latches
- Bit manipulation

Typical applications for the Onboard PLC include:

- Ancillary pumps
- Fans and control valves
- Interlocking logic
- Sequences routines
- Custom control words.

## 11.3 Features

The Digitax HD M Onboard PLC user program has the following features:

### 11.3.1 Tasks

The Onboard PLC allows use of two tasks.

- Clock: A high priority real time task. The clock task interval can be set from 4 ms to 262 s in multiples of 4 ms. The parameter *Onboard User Program: Clock Task Time Used* (11.051) shows the percentage of the available time used by clock task. A read or write of a drive parameter by the user program takes a finite period of

time. It is possible to select up to 10 parameters as fast access parameter which reduced the amount of time it takes for the user program to read from or write to a drive parameter. This is useful when using a clock task with a fast update rate as selecting a parameter for fast access reduces the amount of the clock task resource required to access parameters.

- Freewheeling: A non-real time background task. The freewheeling task is scheduled for a short period once every 64 ms. The time for which the task is scheduled will vary depending on the loading of the drive's processor. When scheduled, several scans of the user program may be performed. Some scans may execute in microseconds. However, when the main drive functions are scheduled there will be a pause in the execution of the program causing some scans to take many milliseconds. The parameter *Onboard User Program: Freewheeling Tasks Per Second* (11.050) shows the number of times the freewheeling task has started per second.

### 11.3.2 Variables

The Onboard PLC supports the use of variables with the data types of Boolean, integer (8 bit, 16 bit and 32 bit, signed and unsigned), floating point (64 bit only), strings and time.

### 11.3.3 Custom menu

Machine Control Studio can construct a custom drive menu to reside in menu 30 on the drive. The following properties of each parameter can be defined using Machine Control Studio:

- Parameter name
- Number of decimal places
- The units for the parameter to be display on the keypad.
- The minimum, maximum and default values
- Memory handling (i.e. power down save, user save or volatile)
- Data type. The drive provides a limited set of 1 bit, 8 bit, 16 bit and 32 bit integer parameters to create the customer menu.

Parameters in this customer menu can be accessed by the user program and will appear on the keypad.

### 11.3.4 Limitations

The Onboard PLC user program has the following limitations:

- The flash memory allocated to the Onboard PLC is 16 kB which includes the user program and its header which results in a maximum user program size of about 12 kB
- The Onboard PLC is provided with 2 kB of RAM.
- The drive is rated for 100 program downloads. This limitation is imposed by the flash memory used to store the program within the drive.
- There is only one real-time task with a minimum period of 4 ms.
- The freewheeling background task runs at a low priority. The drive is prioritized to perform the clock task and its major functions first, e.g. motor control, and will use any remaining processing time to execute the freewheeling task as a background activity. As the drive's processor becomes more heavily loaded, less time is spent executing the freewheeling task.
- Breakpoints, single stepping and online program changes are not possible.
- The Graphing tool is not supported.
- The variable data types REAL (32 bit floating point), LWORD (64 bit integer) and WSTRING (Unicode string), and retained variables are not supported.

## 11.4 Onboard PLC parameters

The following parameters are associated with the Onboard PLC user program.

11.047		Onboard User Program: Enable			
RW	Txt			US	
↕	Stop (0) or Run (1)		⇒	Run (1)	

This parameter stops and starts the user program.

## 0 - Stop the User Program

The onboard user program is stopped. If it is restarted by setting *Onboard User Program: Enable* (11.047) to a non-zero value the background task starts from the beginning.

## 1 - Run the User Program

The user program will execute.

11.048		Onboard User Program: Status			
RO	Txt	NC	PT		
↕	-2147483648 to 2147483647		⇒		

This parameter is read-only and indicates the status of the user program in the drive. The user program writes the value to this parameter.

0: Stopped

1: Running

2: Exception

3: No user program present

11.049		Onboard User Program: Programming Events			
RO	Uni	NC	PT	PS	
↕	0 to 65535		⇒		

This parameter holds the number of times an Onboard PLC user program download has taken place and is 0 on dispatch from the factory. The drive is rated for one hundred program downloads. This parameter is not altered when defaults are loaded.

11.050		Onboard User Program: Freewheeling Tasks Per Second			
RO	Uni	NC	PT		
↕	0 to 65535		⇒		

This parameter shows the number of times the freewheeling task has started per second.

11.051		Onboard User Program: Clock Task Time Used			
RO		NC	PT		
↕	0.0 to 100.0 %		⇒		

This parameter shows the percentage of the available time used by the user program clock task.

11.055		Onboard User Program: Clock Task Scheduled Interval			
RO		NC	PT		
↕	0 to 262128 ms		⇒		

This parameter shows the interval at which the clock task is scheduled to run at in ms.

## 11.5 Onboard PLC trips

If the drive detects an error in the user program it will initiate a User Program trip. The sub-trip number for the User Program trip details the reason for the error. See Chapter 13 *Diagnostics* on page 217 for more information on the User Program trip.

# 12 Advanced parameters

This is a quick reference to all parameters in the drive showing units, ranges limits etc, with block diagrams to illustrate their function. Full descriptions of the parameters can be found in the *Parameter Reference Guide*.



**These advanced parameters are listed for reference purposes only. The lists in this chapter do not include sufficient information for adjusting these parameters. Incorrect adjustment can affect the safety of the system, and damage the drive and or external equipment. Before attempting to adjust any of these parameters, refer to the *Parameter Reference Guide*.**

**Table 12-1 Menu descriptions**

Menu	Description
0	Commonly used basic set up parameters for quick / easy programming
1	Frequency / Speed reference
2	Ramps
3	Frequency slaving, speed feedback and speed control
4	Torque and current control
5	Motor control
6	Sequencer and clock
7	Analog I/O / Temperature monitoring
8	Digital I/O
9	Programmable logic, motorized pot, binary sum, timers and scope
10	Status and trips
11	Drive set-up and identification, serial communications
12	Threshold detectors and variable selectors
13	Standard motion control
14	User PID controller
15	Option module slot 1 set-up menu
16	Option module slot 2 set-up menu
17	Option module slot 3 set-up menu
18	General option module application menu 1
19	General option module application menu 2
20	General option module application menu 3
21	Second motor parameters
22	Menu 0 set-up
23	Not allocated
25	Option module slot 1 application parameters
26	Option module slot 2 application parameters
27	Option module slot 3 application parameters
29	Reserved menu
30	Onboard user programming application menu
31-41	Advanced motion controller setup parameters
Slot 1	Slot 1 option menus*
Slot 2	Slot 2 option menus*
Slot 3	Slot 3 option menus*

\* Only displayed when the option modules are installed.

**Operation mode abbreviations:**

**Open-loop:** Sensorless control for induction motors

**RFC-A:** Asynchronous Rotor Flux Control for induction motors

**RFC-S:** Synchronous Rotor Flux Control for synchronous motors including permanent magnet motors.

**Default abbreviations:**

Standard default value (50 Hz AC supply frequency)

USA default value (60 Hz AC supply frequency)

**NOTE**

Parameter numbers shown in brackets {...} are the equivalent Menu 0 parameters. Some Menu 0 parameters appear twice since their function depends on the operating mode.

The Range - RFC-A / S column applies to both RFC-A and RFC-S. For some parameters, this column applies to only one of these modes, this is indicated accordingly in the Default columns.

In some cases, the function or range of a parameter is affected by the setting of another parameter. The information in the lists relates to the default condition of any parameters affected in this way.

**Table 12-2 Key to parameter table coding**

Coding	Attribute
<b>RW</b>	Read/Write: can be written by the user
<b>RO</b>	Read only: can only be read by the user
<b>Bit</b>	1 bit parameter. 'On' or 'Off' on the display
<b>Num</b>	Number: can be uni-polar or bi-polar
<b>Txt</b>	Text: the parameter uses text strings instead of numbers.
<b>Bin</b>	Binary parameter
<b>IP</b>	IP Address parameter
<b>Mac</b>	Mac Address parameter
<b>Date</b>	Date parameter
<b>Time</b>	Time parameter
<b>Chr</b>	Character parameter
<b>FI</b>	Filtered: some parameters which can have rapidly changing values are filtered when displayed on the drive keypad for easy viewing.
<b>DE</b>	Destination: This parameter selects the destination of an input or logic function.
<b>RA</b>	Rating dependent: this parameter is likely to have different values and ranges with drives of different voltage and current ratings. Parameters with this attribute will be transferred to the destination drive by non-volatile storage media when the rating of the destination drive is different from the source drive and the file is a parameter file. However, the values will be transferred if only the current rating is different and the file is a difference from default type file.
<b>ND</b>	No default: The parameter is not modified when defaults are loaded
<b>NC</b>	Not copied: not transferred to or from non-volatile media during copying.
<b>PT</b>	Protected: cannot be used as a destination.
<b>US</b>	User save: parameter saved in drive EEPROM when the user initiates a parameter save.
<b>PS</b>	Power-down save: parameter automatically saved in drive EEPROM when the under volts (UV) state occurs.

**Table 12-3 Feature look-up table**

Feature	Related parameters (Pr)													
Acceleration rates	02.010	02.011 to 02.019		02.032	02.033	02.034	02.002							
Analog speed reference 1	01.036	07.010	07.001	07.007	07.008	07.009	07.025	07.026	07.030					
Analog I/O	Menu 7													
Analog input 1	07.001	07.007	07.008	07.009	07.010	07.025	07.026	07.030						
Application menu	Menu 18		Menu 19		Menu 20									
At speed indicator bit	03.006	03.007	03.009	10.006	10.005	10.007								
Auto reset	10.034	10.035	10.036	10.001										
Autotune	05.010	05.012	05.017	05.024	05.025	05.029	05.030	05.059	05.060	05.062				
Binary sum	09.029	09.030	09.031	09.032	09.033	09.034								
Bipolar speed	01.010													
Brake control	12.040 to 12.055													
Braking	10.011	10.010	10.030	10.031	06.001	02.004	02.002	10.012	10.039	10.040	10.061			
Catch a spinning motor	06.009	05.040												
Coast to stop	06.001													
Comms	11.023 to 11.027													
Copying	11.042	11.036 to 11.040												
Cost - per kWh electricity	06.016	06.017	06.024	06.025	06.026	06.027	06.028							
Current controller	04.013	04.014												
Current feedback	04.001	04.002	04.017	04.004	04.012	04.020	04.023	04.024	04.026	10.008	10.009	10.017		
Current limits	04.005	04.006	04.007	04.018	04.015	04.019	04.016	05.007	05.010	10.008	10.009	10.017		
DC bus voltage	05.005	02.008												
DC injection braking	06.006	06.007	06.001											
Deceleration rates	02.020	02.021 to 02.029		02.004	02.035 to 02.037		02.002	02.008	06.001	10.030	10.031	10.039	02.009	
Defaults	11.043	11.046												
Digital I/O	Menu 8													
Digital I/O read word	08.020													
Digital Output 1 T14	08.001	08.011	08.021	08.031										
Digital Output 2 T16	08.002	08.012	08.022	08.032										
Digital input 4 T11	08.004	08.014	08.024											
Digital input 5 T13	08.005	08.015	08.025											
Digital lock	13.010	13.001 to 13.009			13.011	13.012	13.016	03.022	03.023	13.019 to 13.023				
Digital output T12	08.008	08.018	08.028											
Direction	10.013	06.030	06.031	01.003	10.014	02.001	03.002		08.004	10.040				
Drive active	10.002	10.040												
Drive derivative	11.028													
Drive OK	10.001	08.027			10.036	10.040								
Dynamic performance	05.026													
Dynamic V/F	05.013													
Enable	06.015	08.009	08.040											
Encoder reference	03.043	03.044	03.045	03.046										
Encoder set-up	03.033	03.034 to 03.042			03.047	03.048								
External trip	10.032	08.010												
Fan speed	06.045													
Fast disable	06.029													
Field weakening - induction motor	05.029	05.030	01.006	05.028	05.062	05.063								
Field weakening - servo	05.022	01.006	05.009											
Filter change	06.019	06.018	06.021	06.022	06.023									
Frequency reference selection	01.014	01.015												
Frequency slaving	03.001	03.013	03.014	03.015	03.016	03.017								
Hard speed reference	03.022	03.023												
Heavy duty rating	05.007	11.032												
High stability space vector modulation	05.019													
I/O sequencer	06.030	06.031	06.032	06.033	06.034	06.042	06.043	06.041						
Inertia compensation	02.038	05.012	04.022	03.018										
Jog reference	01.005	02.019	02.029											
Keypad reference	01.017	01.014	01.043	01.051	06.012	06.013								
Kt	05.032													
Limit switches	06.035	06.036												
Line power supply loss	06.003	10.015	10.016	05.005	06.048									
Local position reference	13.020 to 13.023													
Logic function 1	09.001	09.004	09.005	09.006	09.007	09.008	09.009	09.010						

Feature	Related parameters (Pr)												
Logic function 2	09.002	09.014	09.015	09.016	09.017	09.018	09.019	09.020					
Low voltage supply	06.044												
Marker pulse	03.032	03.031											
Maximum speed	01.006												
Menu 0 set-up	11.018 to 11.022			Menu 22									
Minimum speed	01.007	10.004											
Motor map	05.006	05.007	05.008	05.009	05.010	05.011							
Motor map 2	Menu 21		11.45										
Motorized potentiometer	09.021	09.022	09.023	09.024	09.025	09.026	09.027	09.028					
Offset speed reference	01.004	01.038	01.009										
Onboard PLC	11.047 to 11.051												
Open loop vector mode	05.014	05.017											
Operating mode	00.048	11.031	03.024	05.014									
Orientation	13.010	13.013 to 13.015											
Output	05.001	05.002	05.003	05.004									
Overspeed threshold	03.008												
Phase angle	03.025	05.012											
PID controller	Menu 14												
Position feedback - drive	03.028	03.029	03.030	03.050									
Power up parameter	11.022	11.021											
Precision reference	01.018	01.019	01.020	01.044									
Preset speeds	01.015	01.021 to 01.028			01.016	01.014	01.042	01.045 to 01.048		01.050			
Programmable logic	Menu 9												
Quasi square operation	05.020												
Ramp (accel / decel) mode	02.004	02.008	06.001	02.002	02.003	10.030	10.031	10.039					
Rated speed autotune	05.016	05.008											
Regenerating	10.010	10.011	10.030	10.031	06.001	02.004	02.002	10.012	10.039	10.040			
Relative jog	13.017 to 13.019												
Relay output	08.007	08.017	08.027										
Reset	10.033			10.034	10.035	10.036	10.001	10.038					
RFC mode (encoder less CLV mode)	03.024	03.042	04.012										
S ramp	02.006	02.007											
Sample rates	05.018												
Safe Torque Off input	08.009	08.040											
Security code	11.030	11.044											
Serial comms	11.023 to 11.027			11.020									
Skip speeds	01.029	01.030	01.031	01.032	01.033	01.034	01.035						
Slip compensation	05.027	05.008											
NV media card	11.036 to 11.040			11.042									
Firmware version	11.029	11.034	11.062										
Speed controller	03.010 to 03.017			03.019	03.020	03.021							
Speed feedback	03.002	03.003	03.004										
Speed feedback - drive	03.026	03.027	03.028	03.029	03.030	03.031	03.042						
Speed feed forward	01.039	01.040											
Speed reference selection	01.014	01.015	01.049	01.050	01.001								
Status word	10.040												
Supply	06.044	05.005											
Switching frequency	05.018	05.035	07.034	07.035									
Thermal protection - drive	05.018	05.035	07.004	07.005	07.006	07.034	07.035	07.036	10.018				
Thermal protection - motor	04.015	05.007	04.019	04.016	04.025	07.015							
Thermistor input	03.118 to 03.123												
Threshold detector 1	12.001	12.003 to 12.007											
Threshold detector 2	12.002	12.023 to 12.027											
Time - filter change	06.019	06.018	06.021	06.022	06.023								
Time - powered up log	06.019	06.020											
Time - run log	06.019												
Torque	04.003	04.026	05.032										
Torque mode	04.008	04.011	04.009	04.010									
Trip detection	10.037	10.038	10.020 to 10.029										
Trip log	10.020 to 10.029			10.041 to 10.060			10.070 to 10.079						
Under voltage	05.005	10.016	10.015										
V/F mode	05.015	05.014											
Variable selector 1	12.008 to 12.016												

Feature	Related parameters (Pr)												
Variable selector 2	12.028 to 12.036												
Voltage controller	05.031												
Voltage mode	05.014	05.017		05.015									
Voltage rating	11.033	05.009	05.005										
Voltage supply	06.044		05.005										
Warning	10.019	10.012	10.017	10.018	10.040								
Zero speed indicator bit	03.005	10.003											

## 12.1 Parameter ranges and Variable minimum/maximums

Some parameters in the drive have a variable range with a variable minimum and a variable maximum value which is dependent on one of the following:

- The settings of other parameters
- The drive rating
- The drive mode
- Combination of any of the above

The tables below give the definition of variable minimum/maximum and the maximum range of these.

VM_AC_VOLTAGE		Range applied to parameters showing AC voltage
Units	V	
Range of [MIN]	0	
Range of [MAX]	0 to 930	
Definition	VM_AC_VOLTAGE[MAX] is drive voltage rating dependent. See Table 12-4. VM_AC_VOLTAGE[MIN] = 0	

VM_AC_VOLTAGE_SET		Range applied to the AC voltage set-up parameters
Units	V	
Range of [MIN]	0	
Range of [MAX]	0 to 690	
Definition	VM_AC_VOLTAGE[MAX] is drive voltage rating dependent. See Table 12-4. VM_AC_VOLTAGE[MIN] = 0	

VM_ACCEL_RATE		Maximum applied to the ramp rate parameters
Units	s / 100 Hz, s / 1000 rpm, s / 1000 mm/s	
Range of [MIN]	Open-loop: 0.0 RFC-A, RFC-S: 0.000	
Range of [MAX]	Open-loop: 0.0 to 3200.0 RFC-A, RFC-S: 0.000 to 3200.000	
Definition	<p>Open-loop mode</p> <p>If <i>Ramp Rate Units</i> (02.039) = 0: VM_ACCEL_RATE[MAX] = 3200.0</p> <p>If <i>Ramp Rate Units</i> (02.039) = 1: VM_ACCEL_RATE[MAX] = 3200.0 x Pr <b>01.006</b> / 100.0</p> <p>VM_ACCEL_RATE[MIN] = 0.0</p> <p>RFC-A, RFC-S modes</p> <p>If <i>Ramp Rate Units</i> (02.039) = 0: VM_ACCEL_RATE[MAX] = 3200.000</p> <p>If <i>Ramp Rate Units</i> (02.039) = 1: VM_ACCEL_RATE[MAX] = 3200.000 x Pr <b>01.006</b> / 1000.0</p> <p>VM_ACCEL_RATE[MIN] = 0.000</p> <p>If the second motor map is selected (Pr <b>11.045</b> = 1) Pr <b>21.001</b> is used instead of Pr <b>01.006</b>.</p>	

VM_AMC_JERK_UNIPOLAR		Range applied to the parameters showing the AMC jerk
Units	User units / ms / ms / ms	
Range of [MIN]	0	
Range of [MAX]	107374.1823	
Definition	<p>VM_AMC_JERK_UNIPOLAR[MAX] = 107374.1823 / AMC Auto Resolution Scaling (31.016)</p> <p>VM_AMC_JERK_UNIPOLAR[MIN] = 0</p>	

<b>VM_AMC_POSITION</b>		Range applied to the parameters showing the AMC position		
<b>Unit</b>	User units			
<b>Range of [MIN]</b>	-2147483648			
<b>Range of [MAX]</b>	2147483647			
<b>Definition</b>	VM_AMC_POSITION is modified by <i>AMC Auto Resolution Scaling</i> (31.016) and <i>AMC Roll Over Limit</i> (31.010). See the table below.			
	<b>AMC Roll Over Limit (31.010)</b>	<b>= 0</b>	<b>&gt; 0</b>	
	VM_AMC_POSITION[MAX]	2147483647 / <i>AMC Auto Resolution Scaling</i> (31.016)	AMC Roll Over Limit (31.010) - 1	
	VM_AMC_POSITION[MIN]	-2147483648 / <i>AMC Auto Resolution Scaling</i> (31.016)	0	

<b>VM_AMC_POSITION_CAM</b>		Range applied to the parameters showing the AMC cam position		
<b>Unit</b>	User units			
<b>Range of [MIN]</b>	-1073741824			
<b>Range of [MAX]</b>	1073741823			
<b>Definition</b>	VM_AMC_POSITION_CAM is modified by <i>AMC Auto Resolution Scaling</i> (31.016) and <i>AMC Roll Over Limit</i> (31.010). See the table below.			
	<b>AMC Roll Over Limit (31.010)</b>	<b>= 0</b>	<b>&gt; 0</b>	
	VM_AMC_POSITION_CAM[MAX]	1073741823 / <i>AMC Auto Resolution Scaling</i> (31.016)	AMC Roll Over Limit (31.010) - 1	
	VM_AMC_POSITION_CAM[MIN]	-1073741824 / <i>AMC Auto Resolution Scaling</i> (31.016)	-AMC Roll Over Limit (31.010) + 1	

<b>VM_AMC_POSITION_CAM_UNIPOLAR</b>		Unipolar version of VM_AMC_POSITION_CAM		
<b>Unit</b>	User units			
<b>Range of [MIN]</b>	0			
<b>Range of [MAX]</b>	1073741823			
<b>Definition</b>	VM_AMC_POSITION_CAM_UNIPOLAR is modified by <i>AMC Auto Resolution Scaling</i> (31.016) and <i>AMC Roll Over Limit</i> (31.010). See the table below.			
	<b>AMC Roll Over Limit (31.010)</b>	<b>= 0</b>	<b>&gt; 0</b>	
	VM_AMC_POSITION_CAM_UNIPOLAR[MAX]	1073741823 / <i>AMC Auto Resolution Scaling</i> (31.016)	AMC Roll Over Limit (31.010) - 1	
	VM_AMC_POSITION_CAM_UNIPOLAR[MIN]	0	0	

<b>VM_AMC_POSITION_REF</b>		Range applied to the AMC position reference		
<b>Unit</b>	User units			
<b>Range of [MIN]</b>	-2147483648			
<b>Range of [MAX]</b>	2147483647			
<b>Definition</b>	VM_AMC_POSITION_REF is modified by <i>AMC Auto Resolution Scaling</i> (31.016), <i>AMC Roll Over Limit</i> (31.010) and <i>AMC Rotary Mode</i> (34.005). See the table below.			
	<b>AMC Roll Over Limit (31.010)</b>	<b>= 0</b>	<b>&gt; 0</b>	<b>&gt; 0</b>
	<b>AMC Rotary Mode (34.005)</b>	<b>Not active</b>	<b>&lt; 4</b>	<b>= 4</b>
	VM_AMC_POSITION_REF[MAX]	2147483647 / <i>AMC Auto Resolution Scaling</i> (31.016)	AMC Roll Over Limit (31.010) - 1	1073741823 / <i>AMC Auto Resolution Scaling</i> (31.016)
	VM_AMC_POSITION_REF[MIN]	-2147483648 / <i>AMC Auto Resolution Scaling</i> (31.016)	0	-1073741824 / <i>AMC Auto Resolution Scaling</i> (31.016)

<b>VM_AMC_POSITION_UNIPOLAR</b>		Unipolar version of VM_AMC_POSITION	
Unit	User units		
Range of [MIN]	0		
Range of [MAX]	2147483647		
Definition	VM_AMC_POSITION_UNIPOLAR is modified by <i>AMC Auto Resolution Scaling</i> (31.016) and <i>AMC Roll Over Limit</i> (31.010). See the table below.		
	<b>AMC Roll Over Limit (31.010)</b>	<b>= 0</b>	<b>&gt; 0</b>
	VM_AMC_POSITION_UNIPOLAR[MAX]	2147483647 / <i>AMC Auto Resolution Scaling</i> (31.016)	<i>AMC Roll Over Limit</i> (31.010) - 1
	VM_AMC_POSITION_UNIPOLAR[MIN]	0	0

<b>VM_AMC_RATE</b>		Range applied to the parameters showing the AMC acceleration	
Unit	User units / ms / ms		
Range of [MIN]	1073742.824		
Range of [MAX]	1073741.823		
Definition	VM_AMC_RATE_UNIPOLAR[MAX] = 1073741.823 / <i>AMC Auto Resolution Scaling</i> (31.016)		
	VM_AMC_RATE_UNIPOLAR[MIN] = 1073741.824 / <i>AMC Auto Resolution Scaling</i> (31.016)		

<b>VM_AMC_RATE_UNIPOLAR</b>		Unipolar version of VM_AMC_RATE	
Unit	User units / ms / ms		
Range of [MIN]	0		
Range of [MAX]	1073741.823		
Definition	VM_AMC_RATE_UNIPOLAR[MAX] = 1073741.823 / <i>AMC Auto Resolution Scaling</i> (31.016)		
	VM_AMC_RATE_UNIPOLAR[MIN] = 0		

<b>VM_AMC_ROLLOVER</b>		Maximum applied to the AMC Rollover parameter	
Unit	User units / ms / ms		
Range of [MIN]	0		
Range of [MAX]	1073741823		
Definition	VM_AMC_ROLLOVER[MAX] = 1073741823 / <i>AMC Auto Resolution Scaling</i> (31.016)		
	VM_AMC_ROLLOVER[MIN] = 0		

<b>VM_AMC_SPEED</b>		Range applied to the parameters showing the AMC speed	
Unit	User units / ms / ms		
Range of [MIN]	-21474836.48		
Range of [MAX]	21474836.47		
Definition	VM_AMC_SPEED[MAX] = 21474836.47 / <i>AMC Auto Resolution Scaling</i> (31.016)		
	VM_AMC_SPEED[MIN] = -21474836.48 / <i>AMC Auto Resolution Scaling</i> (31.016)		

<b>VM_AMC_SPEED_UNIPOLAR</b>		Unipolar version of VM_AMC_SPEED	
Unit	User units / ms		
Range of [MIN]	0		
Range of [MAX]	21474836.47		
Definition	VM_SPEED_UNIPOLAR[MAX] = 21474836.47 / <i>AMC Auto Resolution Scaling</i> (31.016)		
	VM_SPEED_UNIPOLAR[MIN] = 0		

<b>VM_DC_VOLTAGE</b>		Range applied to parameters showing DC voltage	
Units	V		
Range of [MIN]	0		
Range of [MAX]	0 to 1190		
Definition	VM_DC_VOLTAGE[MAX] is the full scale d.c. link voltage feedback (over voltage trip level) for the drive. This level is drive voltage rating dependent. See Table 12-4.		
	VM_DC_VOLTAGE[MIN] = 0		

<b>VM_DC_VOLTAGE_SET</b>		Range applied to DC voltage reference parameters
Units	V	
Range of [MIN]	0	
Range of [MAX]	0 to 1150	
Definition	VM_DC_VOLTAGE_SET[MAX] is drive voltage rating dependent. See Table 12-4. VM_DC_VOLTAGE_SET[MIN] = 0	

<b>VM_DRIVE_CURRENT</b>		Range applied to parameters showing current in A
Units	A	
Range of [MIN]	-99999.999 to 0.000	
Range of [MAX]	0.000 to 99999.999	
Definition	VM_DRIVE_CURRENT[MAX] is equivalent to the full scale (over current trip level) for the drive and is given by <i>Full Scale Current Kc</i> (11.061). VM_DRIVE_CURRENT[MIN] = - VM_DRIVE_CURRENT[MAX]	

<b>VM_DRIVE_CURRENT_UNIPOLAR</b>		Unipolar version of VM_DRIVE_CURRENT
Units	A	
Range of [MIN]	0.000	
Range of [MAX]	0.000 to 99999.999	
Definition	VM_DRIVE_CURRENT_UNIPOLAR[MAX] = VM_DRIVE_CURRENT[MAX] VM_DRIVE_CURRENT_UNIPOLAR[MIN] = 0.000	

<b>VM_HIGH_DC_VOLTAGE</b>		Range applied to parameters showing high DC voltage
Units	V	
Range of [MIN]	0	
Range of [MAX]	0 to 1500	
Definition	VM_HIGH_DC_VOLTAGE[MAX] is the full scale d.c. link voltage feedback for the high d.c. link voltage measurement which can measure the voltage if it goes above the normal full scale value. See Table 12-4. VM_HIGH_DC_VOLTAGE[MIN] = 0	

<b>VM_LOW_UNDER_VOLTS</b>		Range applied to the low under-voltage threshold
Units	V	
Range of [MIN]	24	
Range of [MAX]	24 to 1150	
Definition	If <i>Back-up Mode Enable</i> (06.068) = 0: VM_LOW_UNDER_VOLTS[MAX] = VM_STD_UNDER_VOLTS[MIN] If <i>Back-up Mode Enable</i> (06.068) = 1: VM_LOW_UNDER_VOLTS[MAX] = VM_STD_UNDER_VOLTS[MIN] / 1.1. VM_LOW_UNDER_VOLTS[MIN] = 24.	

<b>VM_MIN_SWITCHING_FREQUENCY</b>		Range applied to the minimum switching frequency parameter
Units	User units	
Range of [MIN]	0	
Range of [MAX]	0 to 6	
Definition	VM_MIN_SWITCHING_FREQUENCY[MAX] = <i>Maximum Switching Frequency</i> (05.018) VM_MIN_SWITCHING_FREQUENCY[MIN] = 0 for motor control modes, or 1 for Regen mode (subject to the maximum)	

VM_MOTOR1_CURRENT_LIMIT VM_MOTOR2_CURRENT_LIMIT		Range applied to current limit parameters
<b>Units</b>	%	
<b>Range of [MIN]</b>	0.0	
<b>Range of [MAX]</b>	0.0 to 1000.0	
<b>Definition</b>	VM_MOTOR1_CURRENT_LIMIT[MIN] = 0.0	
	<b>Open-loop</b> VM_MOTOR1_CURRENT_LIMIT[MAX] = $(I_{Tlimit} / I_{Trated}) \times 100 \%$ Where: $I_{Tlimit} = I_{MaxRef} \times \cos(\sin^{-1}(I_{Mrated} / I_{MaxRef}))$ $I_{Mrated} = Pr \ 05.007 \sin \phi$ $I_{Trated} = Pr \ 05.007 \times \cos \phi$ $\cos \phi = Pr \ 05.010$ $I_{MaxRef}$ is 0.7 x Pr 11.061 when the motor rated current set in Pr 05.007 is less than or equal to Pr 11.032 (i.e. Heavy duty).	
	<b>RFC-A</b> VM_MOTOR1_CURRENT_LIMIT[MAX] = $(I_{Tlimit} / I_{Trated}) \times 100 \%$ Where: $I_{Tlimit} = I_{MaxRef} \times \cos(\sin^{-1}(I_{Mrated} / I_{MaxRef}))$ $I_{Mrated} = Pr \ 05.007 \times \sin \phi_1$ $I_{Trated} = Pr \ 05.007 \times \cos \phi_1$ $\phi_1 = \cos^{-1}(Pr \ 05.010) + \phi_2$ . $\phi_1$ is calculated during an autotune. See the variable minimum / maximum calculations in the <i>Parameter Reference Guide</i> for more information regarding $\phi_2$ . $I_{MaxRef}$ is 0.9 x Pr 11.061 when the motor rated current set in Pr 05.007 is less than or equal to Pr 11.032 (i.e. Heavy duty).	
	<b>RFC-S and Regen</b> VM_MOTOR1_CURRENT_LIMIT[MAX] = $(I_{MaxRef} / Pr \ 05.007) \times 100 \%$ Where: $I_{MaxRef}$ is 0.9 x Pr 11.061 when the motor rated current set in Pr 05.007 is less than or equal to Pr 11.032 (i.e. Heavy duty).	
	For VM_MOTOR2_CURRENT_LIMIT[MAX] use Pr 21.007 instead of Pr 05.007 and Pr 21.010 instead of Pr 05.010.	

VM_NEGATIVE_REF_CLAMP1 VM_NEGATIVE_REF_CLAMP2		Limits applied to the negative frequency or speed clamp																	
<b>Units</b>	Open-loop: Hz RFC-A, RFC-S: rpm or mm/s																		
<b>Range of [MIN]</b>	Open-loop: -550.0 to 0.0 RFC-A, RFC-S: -50000.0 to 0.0																		
<b>Range of [MAX]</b>	Open-loop: 0.0 to 550.0 RFC-A, RFC-S: 0.0 to 50000.0																		
<b>Definition</b>	<table border="1"> <thead> <tr> <th>Negative Reference Clamp Enable (01.008)</th> <th>Bipolar Reference Enable (01.010)</th> <th>VM_NEGATIVE_REF_CLAMP1[MIN]</th> <th>VM_NEGATIVE_REF_CLAMP1[MAX]</th> </tr> </thead> <tbody> <tr> <td>0</td> <td>0</td> <td>0.0</td> <td>Pr 01.006</td> </tr> <tr> <td>0</td> <td>1</td> <td>0.0</td> <td>0.0</td> </tr> <tr> <td>1</td> <td>X</td> <td>-VM_POSITIVE_REF_CLAMP1[MAX]</td> <td>0.0</td> </tr> </tbody> </table>			Negative Reference Clamp Enable (01.008)	Bipolar Reference Enable (01.010)	VM_NEGATIVE_REF_CLAMP1[MIN]	VM_NEGATIVE_REF_CLAMP1[MAX]	0	0	0.0	Pr 01.006	0	1	0.0	0.0	1	X	-VM_POSITIVE_REF_CLAMP1[MAX]	0.0
	Negative Reference Clamp Enable (01.008)	Bipolar Reference Enable (01.010)	VM_NEGATIVE_REF_CLAMP1[MIN]	VM_NEGATIVE_REF_CLAMP1[MAX]															
	0	0	0.0	Pr 01.006															
	0	1	0.0	0.0															
1	X	-VM_POSITIVE_REF_CLAMP1[MAX]	0.0																
VM_NEGATIVE_REF_CLAMP2 is defined in the same way except that Pr 21.001 is used instead of Pr 01.006.																			

<b>VM_POSITIVE_REF_CLAMP1</b> <b>VM_POSITIVE_REF_CLAMP2</b>		Limits applied to the positive frequency or speed reference clamp												
<b>Units</b>	Open-loop: Hz RFC-A, RFC-S: rpm or mm/s													
<b>Range of [MIN]</b>	Open-loop: 0.0 RFC-A, RFC-S: 0.0													
<b>Range of [MAX]</b>	Open-loop: 550.0 RFC-A, RFC-S: 0.0 to 50000.0													
<b>Definition</b>	<p>VM_POSITIVE_REF_CLAMP1[MAX] defines the range of the positive reference clamp, <i>Maximum Reference Clamp</i> (01.006), which in turn limit the references. In RFC-A and RFC-S modes a limit is applied so that the position feedback does not exceed the speed where the drive can no longer interpret the feedback signal correctly as given in the table below. The limit is based on the position feedback device selected with <i>Motor Control Feedback Select</i> (03.026). It is possible to disable this limit if the <i>RFC Feedback Mode</i> (03.024) <math>\geq 1</math> (i.e. VM_POSITIVE_REF_CLAMP1 = 50000.0), so that the motor can be operated at a speed above the level where the drive can interpret the feedback in sensorless mode. It should be noted that the position feedback device itself may have a maximum speed limit that is lower than those given in the table. Care should be taken not to exceed a speed that would cause damage to the position feedback device.</p> <table border="1"> <thead> <tr> <th>Feedback device</th> <th>VM_POSITIVE_REF_CLAMP1[MAX]</th> </tr> </thead> <tbody> <tr> <td>AB, AB Servo</td> <td>(500 kHz x 60 / rotary lines per revolution) rpm (500 kHz x linear line pitch in mm) mm/s</td> </tr> <tr> <td>FD, FR, FD Servo, FR Servo</td> <td>(500 kHz x 60 / rotary lines per revolution)/2 rpm (500 kHz x linear line pitch in mm)/2 mm/s</td> </tr> <tr> <td>SC, SC Hiper, SC EnDat, SC SSI, SC Servo</td> <td>(500 kHz x 60 / sine waves per revolution) rpm (500 kHz x linear line pitch in mm) mm/s</td> </tr> <tr> <td>Resolver</td> <td>(250 Hz x 60) rpm (250 Hz x pole pitch in mm) mm/s</td> </tr> <tr> <td>Any other device</td> <td>50000.0 rpm or mm/s</td> </tr> </tbody> </table> <p>In open-loop mode VM_POSITIVE_REF_CLAMP1[MAX] is fixed at 550.0 Hz            In RFC mode a limit is applied to the speed reference of 550 x 60 / Motor pole pairs. Therefore, with a 4 pole motor the limit for VM_POSITIVE_REF_CLAMP1[MAX] will be 16,500 rpm.            VM_POSITIVE_REF_CLAMP1[MIN] = 0.0            VM_POSITIVE_REF_CLAMP2 is defined in the same way as VM_POSITIVE_REF_CLAMP1 except            VM_POSITIVE_REF_CLAMP2[MAX] defines the range of the positive reference clamp, <i>M2 Maximum Reference Clamp</i> (21.001), which in turn limits the references.</p>		Feedback device	VM_POSITIVE_REF_CLAMP1[MAX]	AB, AB Servo	(500 kHz x 60 / rotary lines per revolution) rpm (500 kHz x linear line pitch in mm) mm/s	FD, FR, FD Servo, FR Servo	(500 kHz x 60 / rotary lines per revolution)/2 rpm (500 kHz x linear line pitch in mm)/2 mm/s	SC, SC Hiper, SC EnDat, SC SSI, SC Servo	(500 kHz x 60 / sine waves per revolution) rpm (500 kHz x linear line pitch in mm) mm/s	Resolver	(250 Hz x 60) rpm (250 Hz x pole pitch in mm) mm/s	Any other device	50000.0 rpm or mm/s
	Feedback device	VM_POSITIVE_REF_CLAMP1[MAX]												
	AB, AB Servo	(500 kHz x 60 / rotary lines per revolution) rpm (500 kHz x linear line pitch in mm) mm/s												
	FD, FR, FD Servo, FR Servo	(500 kHz x 60 / rotary lines per revolution)/2 rpm (500 kHz x linear line pitch in mm)/2 mm/s												
	SC, SC Hiper, SC EnDat, SC SSI, SC Servo	(500 kHz x 60 / sine waves per revolution) rpm (500 kHz x linear line pitch in mm) mm/s												
	Resolver	(250 Hz x 60) rpm (250 Hz x pole pitch in mm) mm/s												
	Any other device	50000.0 rpm or mm/s												

<b>VM_POWER</b>		Range applied to parameters that either set or display power
<b>Units</b>	kW	
<b>Range of [MIN]</b>	-99999.999 to 0.000	
<b>Range of [MAX]</b>	0.000 to 99999.999	
<b>Definition</b>	<p>VM_POWER[MAX] is rating dependent and is chosen to allow for the maximum power that can be output by the drive with maximum a.c. output voltage, at maximum controlled current and unity power factor.</p> $VM\_POWER[MAX] = \sqrt{3} \times VM\_AC\_VOLTAGE[MAX] \times VM\_DRIVE\_CURRENT[MAX] / 1000$ <p>VM_POWER[MIN] = -VM_POWER[MAX]</p>	

<b>VM_RATED_CURRENT</b>		Range applied to rated current parameters
<b>Units</b>	A	
<b>Range of [MIN]</b>	0.000	
<b>Range of [MAX]</b>	0.000 to 99999.999	
<b>Definition</b>	<p>VM_RATED_CURRENT [MAX] = <i>Maximum Rated Current</i> (11.060) and is dependent on the drive rating. This is the Heavy Duty rating of the drive.</p> <p>VM_RATED_CURRENT [MIN] = 0.000</p>	

<b>VM_REGEN_REACTIVE</b>		Range applied to the reactive current reference in Regen mode
<b>Units</b>	%	
<b>Range of [MIN]</b>	-1000.0 to 0.0	
<b>Range of [MAX]</b>	0.0 to 1000.0	
<b>Definition</b>	VM_REGEN_REACTIVE[MAX] Applies a limit to the reactive current reference in Regen mode so that the total current reference does not exceed its maximum allowed level.  VM_REGEN_REACTIVE[MIN] = - VM_REGEN_REACTIVE[MAX]	

<b>VM_SPEED</b>		Range applied to parameters showing speed
<b>Units</b>	Open-loop, RFC-A, RFC-S: rpm or mm/s	
<b>Range of [MIN]</b>	Open-loop, RFC-A, RFC-S: -50000.0 to 0.0	
<b>Range of [MAX]</b>	Open-loop, RFC-A, RFC-S: 0.0 to 50000.0	
<b>Definition</b>	This variable minimum/maximum defines the range of speed monitoring parameters. To allow headroom for overshoot the range is set to twice the range of the speed references.  VM_SPEED[MAX] = 2 x VM_SPEED_FREQ_REF[MAX]  VM_SPEED[MIN] = 2 x VM_SPEED_FREQ_REF[MIN]	

<b>VM_SPEED_FREQ_KEYPAD_REF</b>		Range applied to the keypad reference															
<b>Units</b>	Open-loop: Hz RFC-A, RFC-S: rpm or mm/s																
<b>Range of [MIN]</b>	Open-loop: -550.0 to 550.0 RFC-A, RFC-S: -50000.0 to 50000.0																
<b>Range of [MAX]</b>	Open-loop: 0.0 to 550.0 RFC-A, RFC-S: 0.0 to 50000.0																
<b>Definition</b>	This variable maximum is applied to <i>Keypad Control Mode Reference</i> (01.017). The maximum applied to these parameters is the same as other frequency reference parameters. VM_SPEED_FREQ_USER_REFS [MAX] = VM_SPEED_FREQ_REF[MAX] However the minimum is dependent on <i>Negative Reference Clamp Enable</i> (01.008) and <i>Bipolar Reference Enable</i> (01.010). <table border="1" style="width: 100%; margin-top: 10px;"> <thead> <tr> <th>Negative Reference Clamp Enable (01.008)</th> <th>Bipolar Reference Enable (01.010)</th> <th>VM_SPEED_FREQ_USER_REFS[MIN]</th> </tr> </thead> <tbody> <tr> <td style="text-align: center;">0</td> <td style="text-align: center;">0</td> <td>If <i>Select Motor 2 Parameters</i> (11.045) = 0 <i>Minimum Reference Clamp</i> (01.007), otherwise <i>M2 Minimum Reference Clamp</i> (21.002)</td> </tr> <tr> <td style="text-align: center;">0</td> <td style="text-align: center;">1</td> <td>-VM_SPEED_FREQ_REF[MAX]</td> </tr> <tr> <td style="text-align: center;">1</td> <td style="text-align: center;">0</td> <td>0.0</td> </tr> <tr> <td style="text-align: center;">1</td> <td style="text-align: center;">1</td> <td>-VM_SPEED_FREQ_REF[MAX]</td> </tr> </tbody> </table>		Negative Reference Clamp Enable (01.008)	Bipolar Reference Enable (01.010)	VM_SPEED_FREQ_USER_REFS[MIN]	0	0	If <i>Select Motor 2 Parameters</i> (11.045) = 0 <i>Minimum Reference Clamp</i> (01.007), otherwise <i>M2 Minimum Reference Clamp</i> (21.002)	0	1	-VM_SPEED_FREQ_REF[MAX]	1	0	0.0	1	1	-VM_SPEED_FREQ_REF[MAX]
Negative Reference Clamp Enable (01.008)	Bipolar Reference Enable (01.010)	VM_SPEED_FREQ_USER_REFS[MIN]															
0	0	If <i>Select Motor 2 Parameters</i> (11.045) = 0 <i>Minimum Reference Clamp</i> (01.007), otherwise <i>M2 Minimum Reference Clamp</i> (21.002)															
0	1	-VM_SPEED_FREQ_REF[MAX]															
1	0	0.0															
1	1	-VM_SPEED_FREQ_REF[MAX]															

<b>VM_SPEED_FREQ_REF</b>		Range applied to the frequency or speed reference parameters
<b>Units</b>	Open-loop: Hz RFC-A, RFC-S: rpm or mm/s	
<b>Range of [MIN]</b>	Open-loop: -550.0 to 0.0 RFC-A, RFC-S: -50000.0 to 0.0	
<b>Range of [MAX]</b>	Open-loop: 0.0 to 550.0 RFC-A, RFC-S: 0.0 to 50000.0	
<b>Definition</b>	If Pr <b>01.008</b> = 0: VM_SPEED_FREQ_REF[MAX] = Pr <b>01.006</b> If Pr <b>01.008</b> = 1: VM_SPEED_FREQ_REF[MAX] = Pr <b>01.006</b> or  Pr <b>01.007</b>  , whichever is larger. If the second motor map is selected (Pr <b>11.045</b> = 1) Pr <b>21.001</b> is used instead of Pr <b>01.006</b> and Pr <b>21.002</b> instead of Pr <b>01.007</b> .  VM_SPEED_FREQ_REF[MIN] = -VM_SPEED_FREQ_REF[MAX].	

<b>VM_SPEED_FREQ_REF_UNIPOLAR</b>		Unipolar version of VM_SPEED_FREQ_REF
<b>Units</b>	Open-loop: Hz RFC-A, RFC-S: rpm or mm/s	
<b>Range of [MIN]</b>	Open-loop: 0.0 RFC-A, RFC-S: 0.0	
<b>Range of [MAX]</b>	Open-loop: 0.0 to 550.0 RFC-A, RFC-S: 0.0 to 50000.0	
<b>Definition</b>	VM_SPEED_FREQ_REF_UNIPOLAR[MAX] = VM_SPEED_FREQ_REF[MAX] VM_SPEED_FREQ_REF_UNIPOLAR[MIN] = 0.0	

<b>VM_SPEED_FREQ_USER_REFS</b>		Range applied to Analog reference parameters	
<b>Units</b>	Open-loop: Hz RFC-A, RFC-S: rpm or mm/s		
<b>Range of [MIN]</b>	Open-loop: -550.00 to 550.00 RFC-A, RFC-S: -50000.0 to 50000.0		
<b>Range of [MAX]</b>	Open-loop: 0.00 to 550.00 RFC-A, RFC-S: 0.0 to 50000.0		
<b>Definition</b>	VM_SPEED_FREQ_USER_REFS= VM_SPEED_FREQ_REF[MAX]		
	<i>Negative Reference Clamp Enable (01.008)</i>	<i>Bipolar Reference Enable (01.010)</i>	<b>VM_SPEED_FREQ_USER_REFS [MIN]</b>
	0	0	Pr <b>01.007</b>
	0	1	-VM_SPEED_FREQ_REF[MAX]
	1	0	0.0
	1	1	-VM_SPEED_FREQ_REF[MAX]
If the second motor map is selected (Pr <b>11.045</b> = 1) Pr <b>21.002</b> is used instead of Pr <b>01.007</b> .			

<b>VM_STD_UNDER_VOLTS</b>		Range applied to the standard under-voltage threshold
<b>Units</b>	V	
<b>Range of [MIN]</b>	0 to 1150	
<b>Range of [MAX]</b>	0 to 1150	
<b>Definition</b>	VM_STD_UNDER_VOLTS[MAX] = VM_DC_VOLTAGE_SET / 1.1 VM_STD_UNDER_VOLTS[MIN] is voltage rating dependent. See Table 12-4	

<b>VM_SUPPLY_LOSS_LEVEL</b>		Range applied to the supply loss threshold
<b>Units</b>	V	
<b>Range of [MIN]</b>	0 to 1150	
<b>Range of [MAX]</b>	0 to 1150	
<b>Definition</b>	VM_SUPPLY_LOSS_LEVEL[MAX] = VM_DC_VOLTAGE_SET[MAX] VM_SUPPLY_LOSS_LEVEL[MIN] is drive voltage rating dependent. See Table 12-4	

<b>VM_SWITCHING_FREQUENCY</b>		Range applied to the maximum switching frequency parameters
<b>Units</b>	User units	
<b>Range of [MIN]</b>	0	
<b>Range of [MAX]</b>	0 to 6	
<b>Definition</b>	VM_SWITCHING_FREQUENCY[MAX] = Power stage dependent VM_SWITCHING_FREQUENCY[MIN] = 0 for motor control modes, or 1 for Regen mode (subject to the maximum)	

<b>VM_TORQUE_CURRENT</b>		Range applied to torque and torque producing current parameters (where this is used in Regen mode it refers to the active current)	
<b>Units</b>	%		
<b>Range of [MIN]</b>	-1000.0 to 0.0		
<b>Range of [MAX]</b>	0.0 to 1000.0		
<b>Definition</b>	<b>Select Motor 2 Parameters (11.045)</b>		<b>VM_TORQUE_CURRENT [MAX]</b>
	0		VM_MOTOR1_CURRENT_LIMIT[MAX]
	1		VM_MOTOR2_CURRENT_LIMIT[MAX]
VM_TORQUE_CURRENT[MIN] = -VM_TORQUE_CURRENT[MAX]			

<b>VM_TORQUE_CURRENT_UNIPOLAR</b>		Unipolar version of VM_TORQUE_CURRENT	
<b>Units</b>	%		
<b>Range of [MIN]</b>	0.0		
<b>Range of [MAX]</b>	0.0 to 1000.0		
<b>Definition</b>	VM_TORQUE_CURRENT_UNIPOLAR[MAX] = VM_TORQUE_CURRENT[MAX] VM_TORQUE_CURRENT_UNIPOLAR[MIN] = 0.0		

<b>VM_USER_CURRENT</b>		Range applied to torque reference and percentage load parameters with one decimal place	
<b>Units</b>	%		
<b>Range of [MIN]</b>	-1000.0 to 0.0		
<b>Range of [MAX]</b>	0.0 to 1000.0		
<b>Definition</b>	<p>VM_USER_CURRENT[MAX] = <i>User Current Maximum Scaling</i> (04.024)</p> <p>VM_USER_CURRENT[MIN] = -VM_USER_CURRENT[MAX]</p> <p><i>User Current Maximum Scaling</i> (04.024) defines the variable maximum/minimums VM_USER_CURRENT and VM_USER_CURRENT_HIGH_RES which are applied to <i>Percentage Load</i> (04.020), <i>Torque Reference</i> (04.008) and <i>Torque Offset</i> (04.009). This is useful when routing these parameters to an analog output as it allows the full scale output value to be defined by the user.</p> <p>The maximum value (VM_TORQUE_CURRENT_UNIPOLAR [MAX]) varies between drive sizes with default parameters loaded. For some drive sizes the default value may be reduced below the value given by the parameter range limiting.</p>		

<b>VM_USER_CURRENT_HIGH_RES</b>		Range applied to torque reference and percentage load parameters with two decimal places	
<b>Units</b>	%		
<b>Range of [MIN]</b>	-1000.00 to 0.00		
<b>Range of [MAX]</b>	0.00 to 1000.00		
<b>Definition</b>	<p>VM_USER_CURRENT_HIGH_RES[MAX] = <i>User Current Maximum Scaling</i> (04.024) with an additional decimal place</p> <p>VM_USER_CURRENT_HIGH_RES[MIN] = -VM_USER_CURRENT_HIGH_RES[MAX]</p> <p><i>User Current Maximum Scaling</i> (04.024) defines the variable maximum/minimums VM_USER_CURRENT and VM_USER_CURRENT_HIGH_RES which are applied to <i>Percentage Load</i> (04.020), <i>Torque Reference</i> (04.008) and <i>Torque Offset</i> (04.009). This is useful when routing these parameters to an analog output as it allows the full scale output value to be defined by the user.</p> <p>The maximum value (VM_TORQUE_CURRENT_UNIPOLAR [MAX]) varies between drive sizes with default parameters loaded. For some drive sizes the default value may be reduced below the value given by the parameter range limiting.</p>		

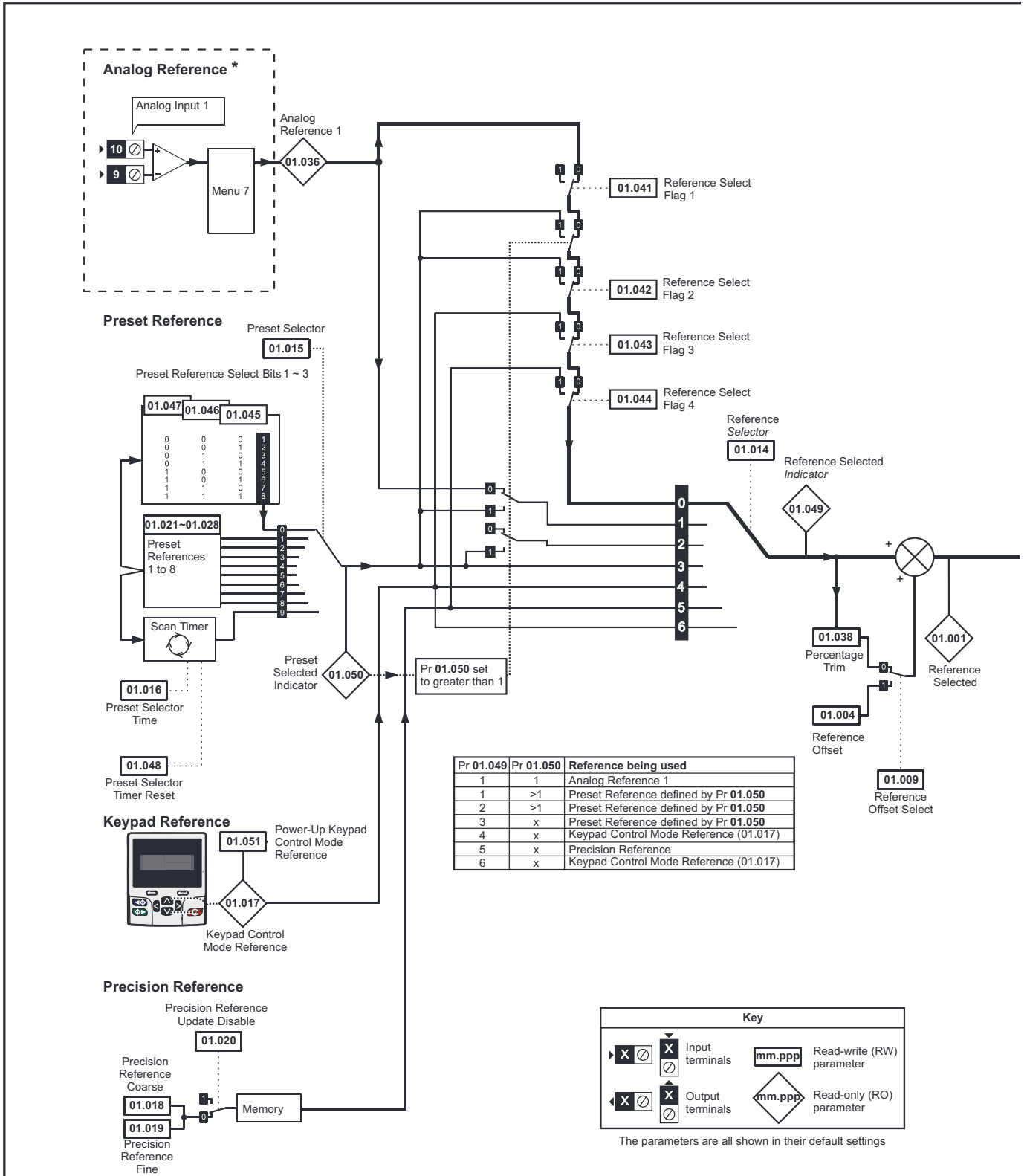
**Table 12-4 Voltage ratings dependant values**

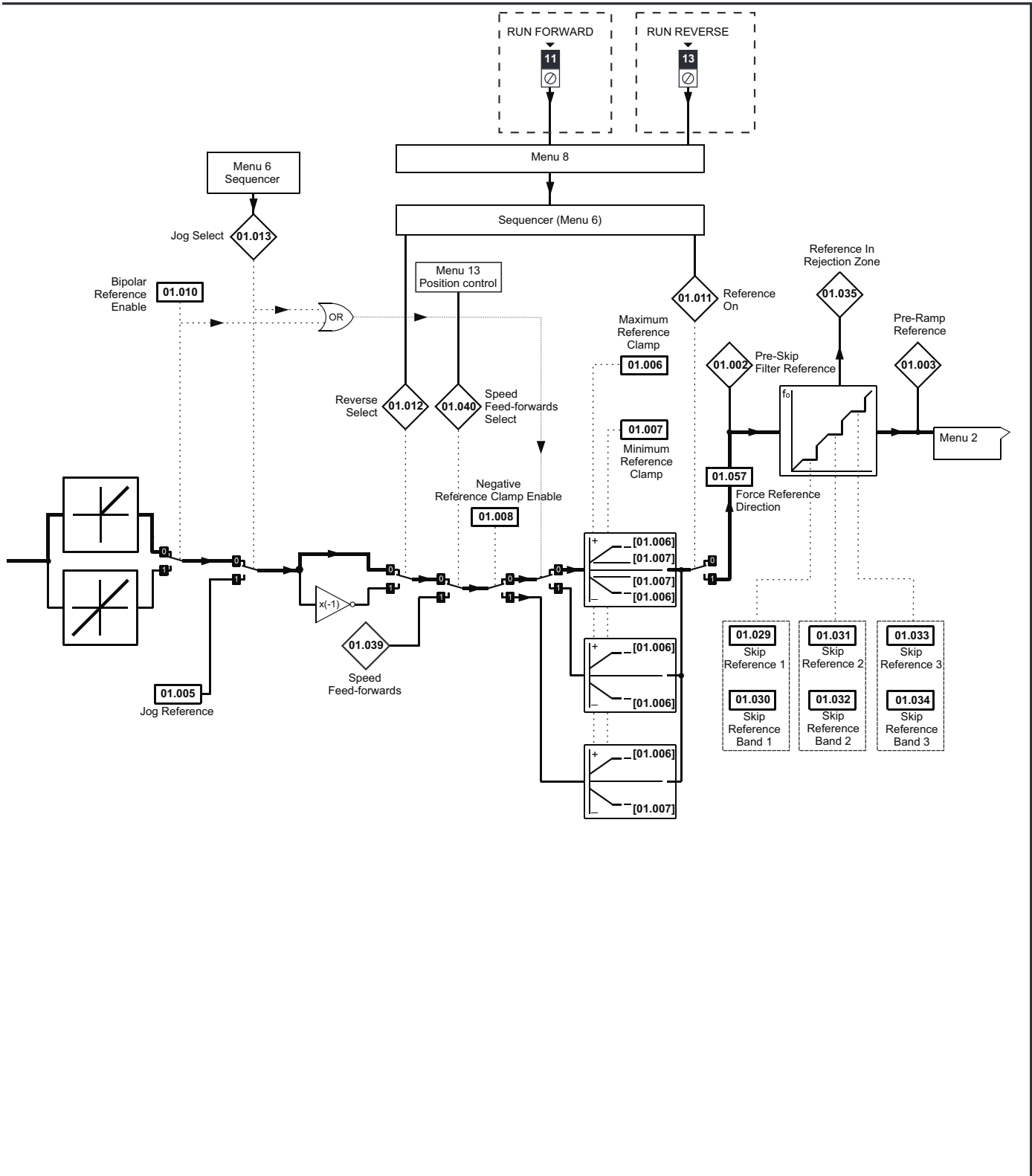
Variable min/max	Voltage level (V)	
	200 V	400 V
VM_DC_VOLTAGE_SET[MAX]	400	800
VM_DC_VOLTAGE[MAX]	415	830
VM_AC_VOLTAGE_SET[MAX]	265	530
VM_AC_VOLTAGE[MAX]	325	650
VM_STD_UNDER_VOLTS[MIN]	175	330
VM_SUPPLY_LOSS_LEVEL[MIN]	205	410
VM_HIGH_DC_VOLTAGE[MAX]	1500	1500

Safety information	Product information	Mechanical installation	Electrical installation	Getting started	Basic parameters	Running the motor	Optimization	Drive communication	SD Card Operation	Onboard PLC	<b>Advanced parameters</b>	Diagnostics	UL listing information
--------------------	---------------------	-------------------------	-------------------------	-----------------	------------------	-------------------	--------------	---------------------	-------------------	-------------	----------------------------	-------------	------------------------

## 12.2 Menu 1: Frequency / speed reference

Figure 12-1 Menu 1 logic diagram





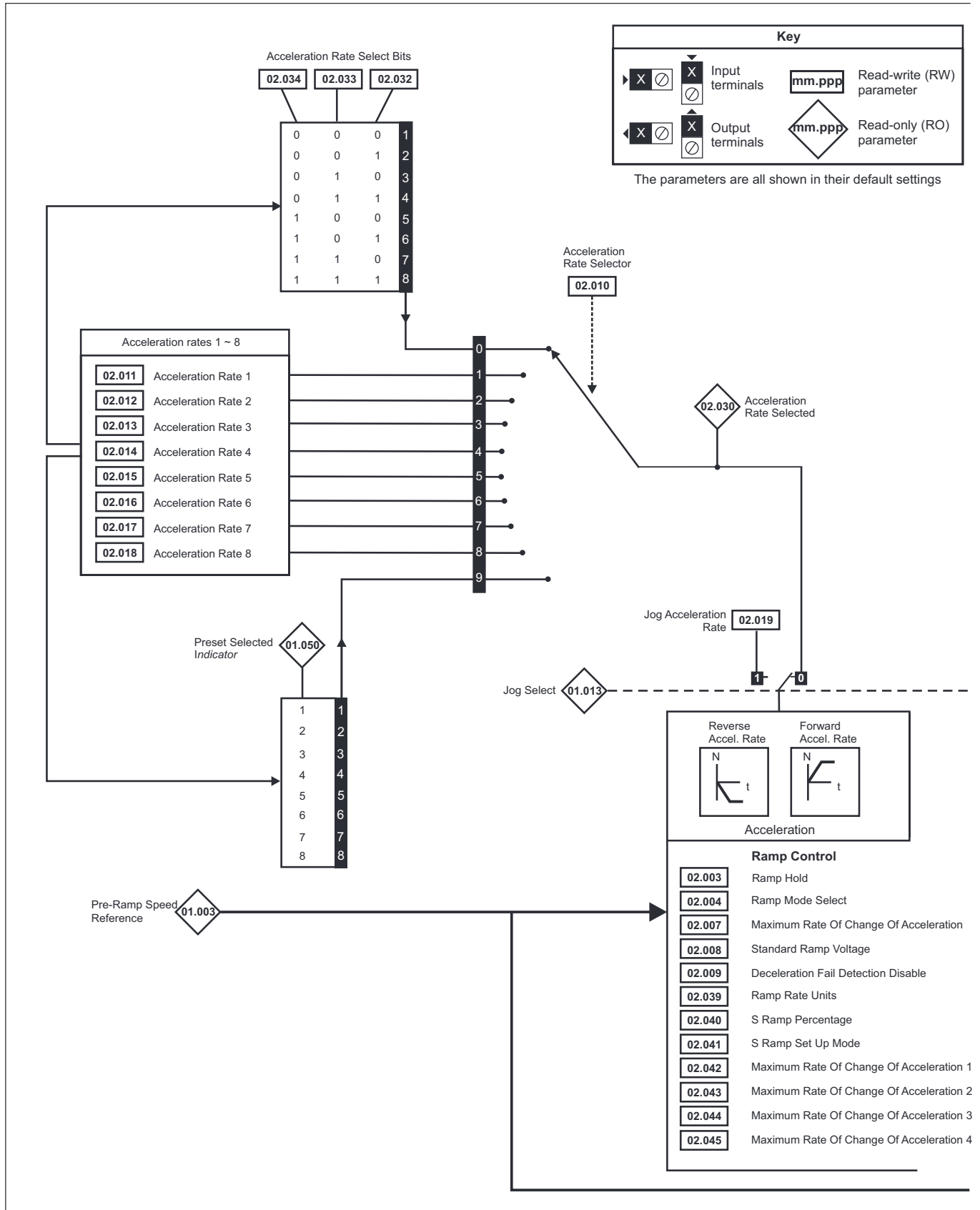
Parameter	Range(φ)		Default(⇒)			Type				
	OL	RFC-A / S	OL	RFC-A	RFC-S	RO	Num	ND	NC	PT
01.001	Reference Selected	VM_SPEED_FREQ_REF Hz	VM_SPEED_FREQ_REF rpm			RO	Num	ND	NC	PT
01.002	Pre-Skip Filter Reference	VM_SPEED_FREQ_REF Hz	VM_SPEED_FREQ_REF rpm			RO	Num	ND	NC	PT
01.003	Pre-Ramp Reference	VM_SPEED_FREQ_REF Hz	VM_SPEED_FREQ_REF rpm			RO	Num	ND	NC	PT
01.004	Reference Offset	VM_SPEED_FREQ_REF Hz	VM_SPEED_FREQ_REF rpm	0.0		RW	Num			US
01.005	Jog Reference	0.0 to 400.0 Hz	0.0 to 4000.0 rpm	0.0		RW	Num			US
01.006	Maximum Reference Clamp	VM_POSITIVE_REF_CLAMP1 Hz	VM_POSITIVE_REF_CLAMP1 rpm	50 Hz: 50.0 60 Hz: 60.0	50Hz: 1500.0 60Hz: 1800.0	3000.0	RW	Num		US
01.007	Minimum Reference Clamp	VM_NEGATIVE_REF_CLAMP1 Hz	VM_NEGATIVE_REF_CLAMP1 rpm	0.0		RW	Num			US
01.008	Negative Reference Clamp Enable	Off (0) or On (1)		Off (0)		RW	Bit			US
01.009	Reference Offset Select	Off (0) or On (1)		Off (0)		RW	Bit			US
01.010	Bipolar Reference Enable	Off (0) or On (1)		On (1)		RW	Bit			US
01.011	Reference On	Off (0) or On (1)				RO	Bit	ND	NC	PT
01.012	Reverse Select	Off (0) or On (1)				RO	Bit	ND	NC	PT
01.013	Jog Select	Off (0) or On (1)				RO	Bit	ND	NC	PT
01.014	Reference Selector	A1 A2 (0), A1 Preset (1), A2 Preset (2), Preset (3), Keypad (4), Precision (5), Keypad Ref (6)		A1 Preset (1)		RW	Txt			US
01.015	Preset Selector	0 to 9		0		RW	Num			US
01.016	Preset Selector Time	0.0 to 400.0 s		10.0 s		RW	Num			US
01.017	Keypad Control Mode Reference	VM_SPEED_FREQ_KEYPAD_REF		0.0		RO	Num		NC	PT
01.018	Precision Reference Coarse	VM_SPEED_FREQ_REF		0.0		RW	Num			US
01.019	Precision Reference Fine	0.000 to 0.099 Hz	0.000 to 0.099 rpm	0.000		RW	Num			US
01.020	Precision Reference Update Disable	Off (0) or On (1)		Off (0)		RW	Bit		NC	
01.021	Preset Reference 1	VM_SPEED_FREQ_REF		0.0		RW	Num			US
01.022	Preset Reference 2	VM_SPEED_FREQ_REF		0.0		RW	Num			US
01.023	Preset Reference 3	VM_SPEED_FREQ_REF		0.0		RW	Num			US
01.024	Preset Reference 4	VM_SPEED_FREQ_REF		0.0		RW	Num			US
01.025	Preset Reference 5	VM_SPEED_FREQ_REF		0.0		RW	Num			US
01.026	Preset Reference 6	VM_SPEED_FREQ_REF		0.0		RW	Num			US
01.027	Preset Reference 7	VM_SPEED_FREQ_REF		0.0		RW	Num			US
01.028	Preset Reference 8	VM_SPEED_FREQ_REF		0.0		RW	Num			US
01.029	Skip Reference 1	0.0 to 550.0 Hz	0 to 33, 000 rpm	0.0	0	RW	Num			US
01.030	Skip Reference Band 1	0.0 to 25.0 Hz	0 to 250 rpm	0.0	0	RW	Num			US
01.031	Skip Reference 2	0.0 to 550.0 Hz	0 to 33, 000 rpm	0.0	0	RW	Num			US
01.032	Skip Reference Band 2	0.0 to 25.0 Hz	0 to 250 rpm	0.0	0	RW	Num			US
01.033	Skip Reference 3	0.0 to 550.0 Hz	0 to 33, 000 rpm	0.0	0	RW	Num			US
01.034	Skip Reference Band 3	0.0 to 25.0 Hz	0 to 250 rpm	0.0	0	RW	Num			US
01.035	Reference In Rejection Zone	Off (0) or On (1)				RO	Bit	ND	NC	PT
01.036	Analog Reference 1	VM_SPEED_FREQ_USER_	VM_SPEED_FREQ_USER_	0.0		RO	Num		NC	
01.037	Analog Reference 2	REFS Hz	REFS rpm	0.0		RO	Num		NC	
01.038	Percentage Trim	±100.00 %		0.00 %		RW	Num		NC	
01.039	Speed Feed-forwards	VM_SPEED_FREQ_REF				RO	Num	ND	NC	PT
01.040	Speed Feed-forwards Select	Off (0) or On (1)				RO	Bit	ND	NC	PT
01.041	Reference Select Flag 1	Off (0) or On (1)		Off (0)		RW	Bit		NC	
01.042	Reference Select Flag 2	Off (0) or On (1)		Off (0)		RW	Bit		NC	
01.043	Reference Select Flag 3	Off (0) or On (1)		Off (0)		RW	Bit		NC	
01.044	Reference Select Flag 4	Off (0) or On (1)		Off (0)		RW	Bit		NC	
01.045	Preset Select Flag 1	Off (0) or On (1)		Off (0)		RW	Bit		NC	
01.046	Preset Select Flag 2	Off (0) or On (1)		Off (0)		RW	Bit		NC	
01.047	Preset Select Flag 3	Off (0) or On (1)		Off (0)		RW	Bit		NC	
01.048	Preset Selector Timer Reset	Off (0) or On (1)		Off (0)		RW	Bit		NC	
01.049	Reference Selected Indicator	1 to 6				RO	Num	ND	NC	PT
01.050	Preset Selected Indicator	1 to 8				RO	Num	ND	NC	PT
01.051	Power-up Keypad Control Mode Reference	Reset (0), Last (1), Preset (2)		Reset (0)		RW	Txt			US
01.055	Linear Speed Select	Off (0) or On (1)		Off (0)		RW	Bit			US
01.056	Linear Speed Selected	Off (0) or On (1)				RO	Bit	ND	NC	PT
01.057	Force Reference Direction	None (0), Forward (1), Reverse (2)		None (0)		RW	Txt			

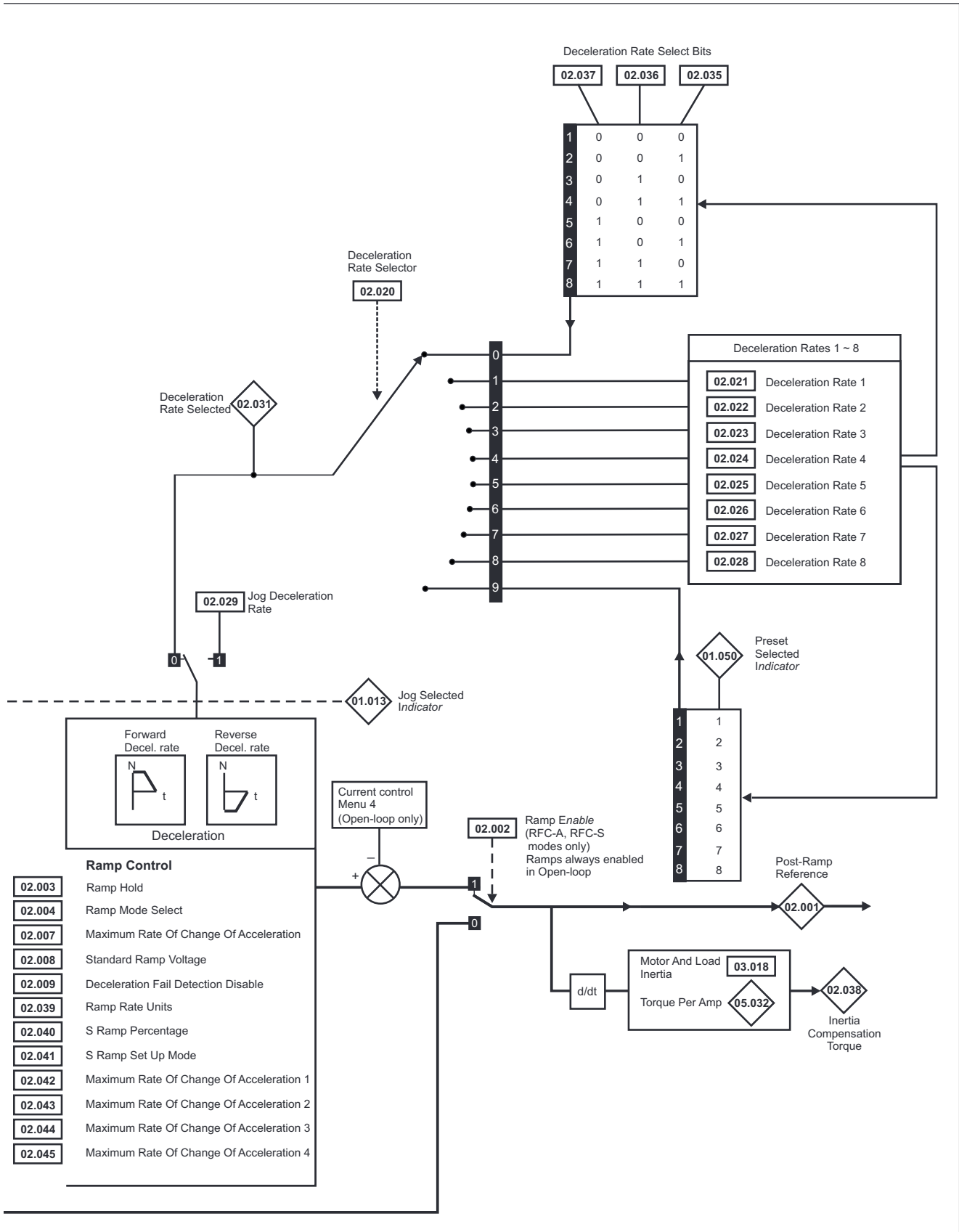
RW	Read / Write	RO	Read only	Num	Number parameter	Bit	Bit parameter	Txt	Text string	Bin	Binary parameter	FI	Filtered
ND	No default value	NC	Not copied	PT	Protected parameter	RA	Rating dependent	US	User save	PS	Power-down save	DE	Destination

Safety information	Product information	Mechanical installation	Electrical installation	Getting started	Basic parameters	Running the motor	Optimization	Drive communication	SD Card Operation	Onboard PLC	<b>Advanced parameters</b>	Diagnostics	UL listing information
--------------------	---------------------	-------------------------	-------------------------	-----------------	------------------	-------------------	--------------	---------------------	-------------------	-------------	----------------------------	-------------	------------------------

## 12.3 Menu 2: Ramps

Figure 12-2 Menu 2 logic diagram



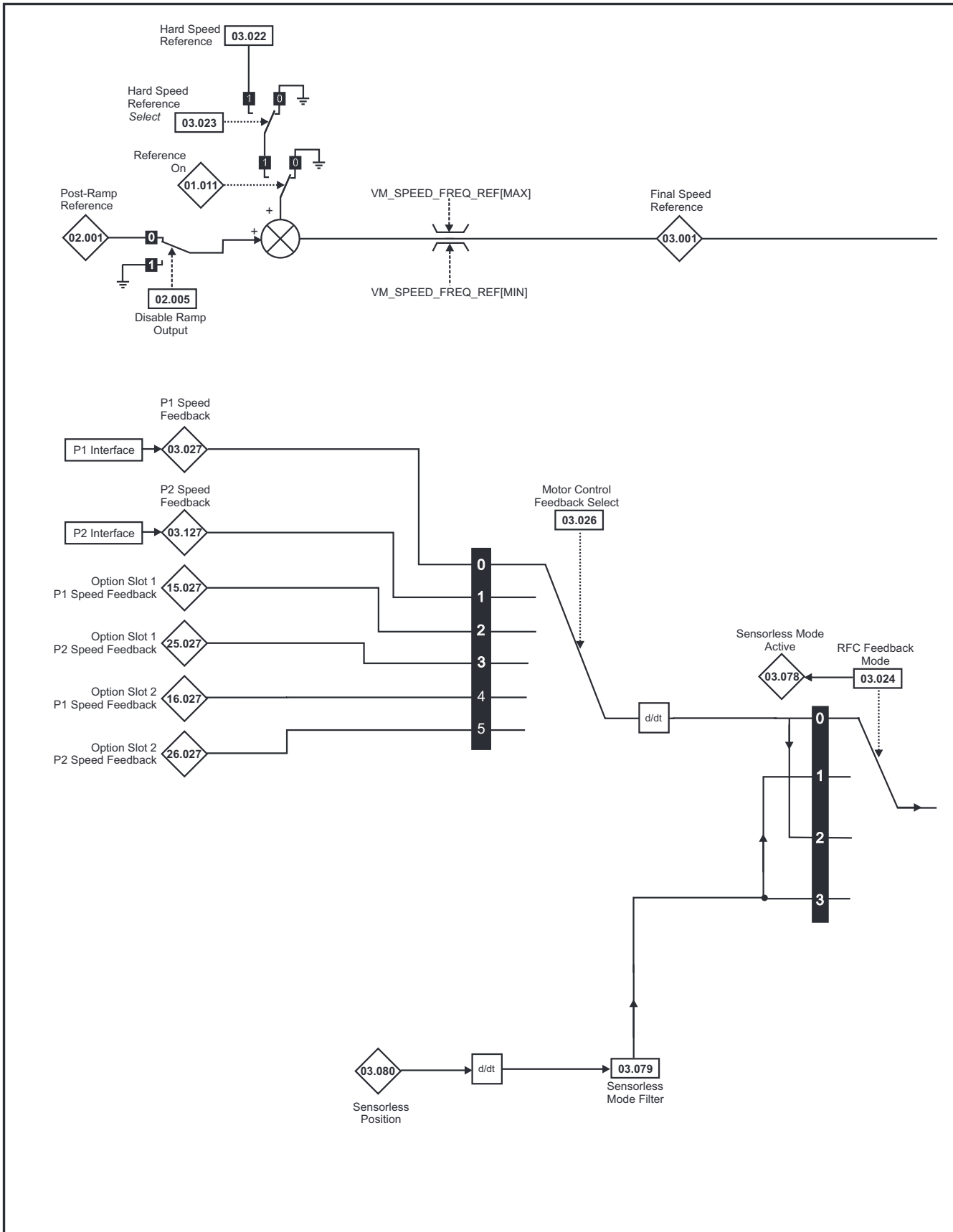


Parameter		Range(↕)		Default(⇨)			Type						
		OL	RFC-A / S	OL	RFC-A	RFC-S	RO	Num	ND	NC	PT		
02.001	Post Ramp Reference	VM_SPEED_FREQ_REF Hz	VM_SPEED_FREQ_REF rpm				RO	Num	ND	NC	PT		
02.002	Ramp Enable		Off (0) or On (1)			On (1)	RW	Bit					US
02.003	Ramp Hold		Off (0) or On (1)			Off (0)	RW	Bit					US
02.004	Ramp Mode	Fast (0), Standard (1), Std boost (2)	Fast (0), Standard (1)	Standard (1)		Fast (0)	RW	Txt					US
02.005	Disable Ramp Output		Off (0) or On (1)			Off (0)	RW	Bit					US
02.006	S Ramp Enable		Off (0) or On (1)			Off (0)	RW	Bit					US
02.007	Maximum Rate Of Change Of Acceleration	0.0 to 300.0 s <sup>2</sup> /100 Hz	0.000 to 100.000 s <sup>2</sup> /1000 rpm	3.1	1.500	0.030	RW	Num					US
02.008	Standard Ramp Voltage	0 to VM_DC_VOLTAGE_SET V		200 V drive: 375 V 50 Hz - 400 V drive: 750 V 60 Hz - 400 V drive: 775 V			RW	Num		RA			US
02.009	Deceleration Fail Detection Disable		Off (0) or On (1)			Off (0)	RW	Bit					US
02.010	Acceleration Rate Selector		0 to 9			0	RW	Num					US
02.011	Acceleration Rate 1	0.0 to VM_ACCEL_RATE s/100 Hz	0.000 to VM_ACCEL_RATE s/1000 rpm	5.0 s	2.000 s	0.200 s	RW	Num					US
02.012	Acceleration Rate 2	0.0 to VM_ACCEL_RATE s/100 Hz	0.000 to VM_ACCEL_RATE s/1000 rpm	5.0 s	2.000 s	0.200 s	RW	Num					US
02.013	Acceleration Rate 3	0.0 to VM_ACCEL_RATE s/100 Hz	0.000 to VM_ACCEL_RATE s/1000 rpm	5.0 s	2.000 s	0.200 s	RW	Num					US
02.014	Acceleration Rate 4	0.0 to VM_ACCEL_RATE s/100 Hz	0.000 to VM_ACCEL_RATE s/1000 rpm	5.0 s	2.000 s	0.200 s	RW	Num					US
02.015	Acceleration Rate 5	0.0 to VM_ACCEL_RATE s/100 Hz	0.000 to VM_ACCEL_RATE s/1000 rpm	5.0 s	2.000 s	0.200 s	RW	Num					US
02.016	Acceleration Rate 6	0.0 to VM_ACCEL_RATE s/100 Hz	0.000 to VM_ACCEL_RATE s/1000 rpm	5.0 s	2.000 s	0.200 s	RW	Num					US
02.017	Acceleration Rate 7	0.0 to VM_ACCEL_RATE s/100 Hz	0.000 to VM_ACCEL_RATE s/1000 rpm	5.0 s	2.000 s	0.200 s	RW	Num					US
02.018	Acceleration Rate 8	0.0 to VM_ACCEL_RATE s/100 Hz	0.000 to VM_ACCEL_RATE s/1000 rpm	5.0 s	2.000 s	0.200 s	RW	Num					US
02.019	Jog Acceleration Rate	0.0 to VM_ACCEL_RATE s/100 Hz	0.000 to VM_ACCEL_RATE s/1000 rpm	0.2 s	0.000 s		RW	Num					US
02.020	Deceleration Rate Selector		0 to 9			0	RW	Num					US
02.021	Deceleration Rate 1	0.0 to VM_ACCEL_RATE s/100 Hz	0.000 to VM_ACCEL_RATE s/1000 rpm	10.0 s	2.000 s	0.200 s	RW	Num					US
02.022	Deceleration Rate 2	0.0 to VM_ACCEL_RATE s/100 Hz	0.000 to VM_ACCEL_RATE s/1000 rpm	10.0 s	2.000 s	0.200 s	RW	Num					US
02.023	Deceleration Rate 3	0.0 to VM_ACCEL_RATE s/100 Hz	0.000 to VM_ACCEL_RATE s/1000 rpm	10.0 s	2.000 s	0.200 s	RW	Num					US
02.024	Deceleration Rate 4	0.0 to VM_ACCEL_RATE s/100 Hz	0.000 to VM_ACCEL_RATE s/1000 rpm	10.0 s	2.000 s	0.200 s	RW	Num					US
02.025	Deceleration Rate 5	0.0 to VM_ACCEL_RATE s/100 Hz	0.000 to VM_ACCEL_RATE s/1000 rpm	10.0 s	2.000 s	0.200 s	RW	Num					US
02.026	Deceleration Rate 6	0.0 to VM_ACCEL_RATE s/100 Hz	0.000 to VM_ACCEL_RATE s/1000 rpm	10.0 s	2.000 s	0.200 s	RW	Num					US
02.027	Deceleration Rate 7	0.0 to VM_ACCEL_RATE s/100 Hz	0.000 to VM_ACCEL_RATE s/1000 rpm	10.0 s	2.000 s	0.200 s	RW	Num					US
02.028	Deceleration Rate 8	0.0 to VM_ACCEL_RATE s/100 Hz	0.000 to VM_ACCEL_RATE s/1000 rpm	10.0 s	2.000 s	0.200 s	RW	Num					US
02.029	Jog Deceleration Rate	0.0 to VM_ACCEL_RATE s/100 Hz	0.000 to VM_ACCEL_RATE s/1000 rpm	0.2 s	0.000 s		RW	Num					US
02.030	Acceleration Rate Selected		0 to 8				RO	Num	ND	NC	PT		
02.031	Deceleration Rate Selected		0 to 8				RO	Num	ND	NC	PT		
02.032	Acceleration Rate Select Bit 0		Off (0) or On (1)			Off (0)	RW	Bit		NC			
02.033	Acceleration Rate Select Bit 1		Off (0) or On (1)			Off (0)	RW	Bit		NC			
02.034	Acceleration Rate Select Bit 2		Off (0) or On (1)			Off (0)	RW	Bit		NC			
02.035	Deceleration Rate Select Bit 0		Off (0) or On (1)			Off (0)	RW	Bit		NC			
02.036	Deceleration Rate Select Bit 1		Off (0) or On (1)			Off (0)	RW	Bit		NC			
02.037	Deceleration Rate Select Bit 2		Off (0) or On (1)			Off (0)	RW	Bit		NC			
02.038	Inertia Compensation Torque		±1000.0 %				RO	Num	ND	NC	PT		
02.039	Ramp Rate Units		Off (0) or On (1)			Off (0)	RW	Bit					US
02.040	S Ramp Percentage		0.0 to 50.0 %			0.0 %	RW						US
02.041	S Ramp Set-up Mode		Single (0), Percentage (1), Independent (2)			Single (0)	RW	Txt					US
02.042	Maximum Rate Of Change Of Acceleration 1	0.0 to 300.0	0.000 to 100.000	0.0	0.000		RW	Num					US
02.043	Maximum Rate Of Change Of Acceleration 2	0.0 to 300.0	0.000 to 100.000	0.0	0.000		RW	Num					US
02.044	Maximum Rate Of Change Of Acceleration 3	0.0 to 300.0	0.000 to 100.000	0.0	0.000		RW	Num					US
02.045	Maximum Rate Of Change Of Acceleration 4	0.0 to 300.0	0.000 to 100.000	0.0	0.000		RW	Num					US

RW	Read / Write	RO	Read only	Num	Number parameter	Bit	Bit parameter	Txt	Text string	Bin	Binary parameter	FI	Filtered
ND	No default value	NC	Not copied	PT	Protected parameter	RA	Rating dependent	US	User save	PS	Power-down save	DE	Destination

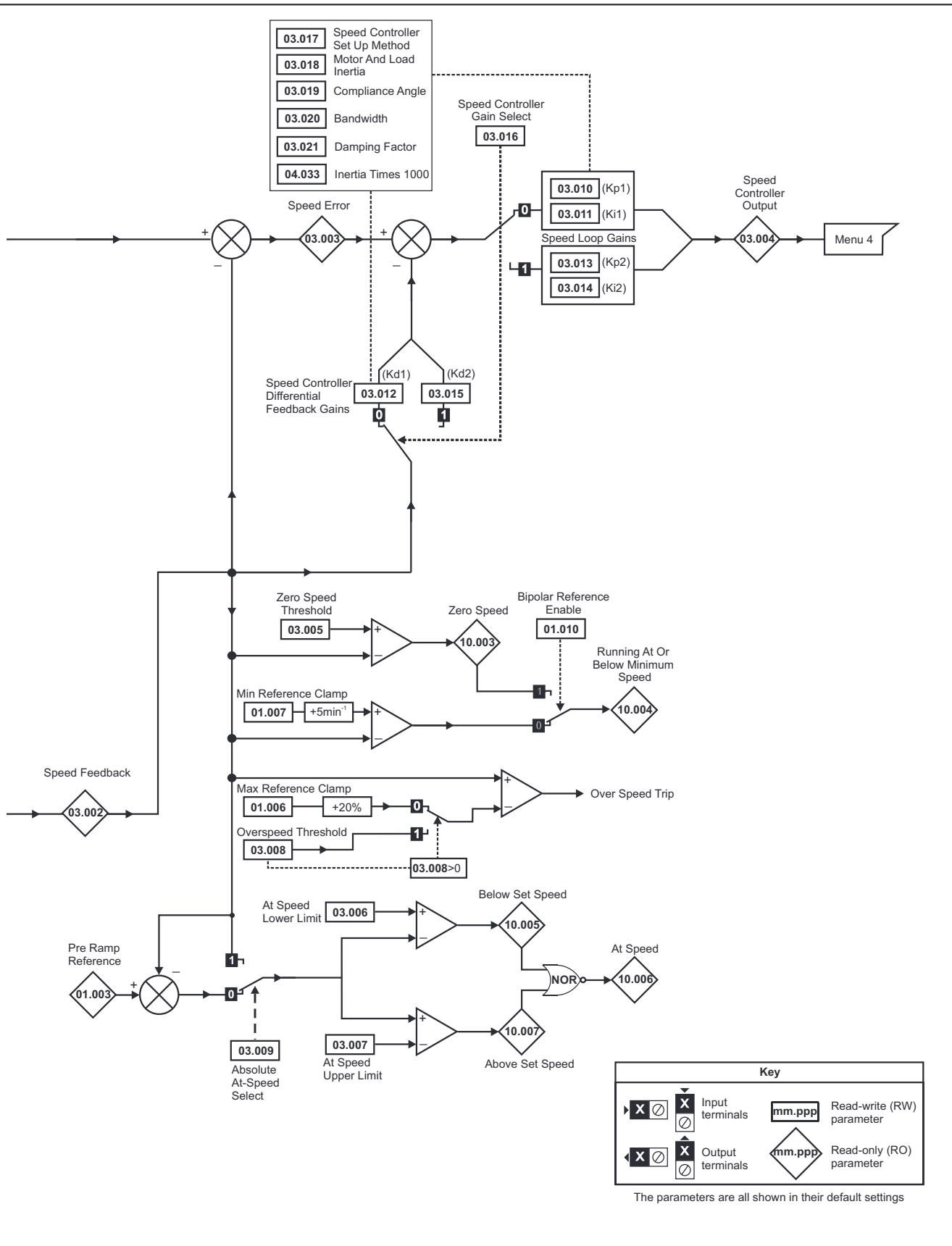


Figure 12-4 Menu 3 RFC-A, RFC-S logic diagram

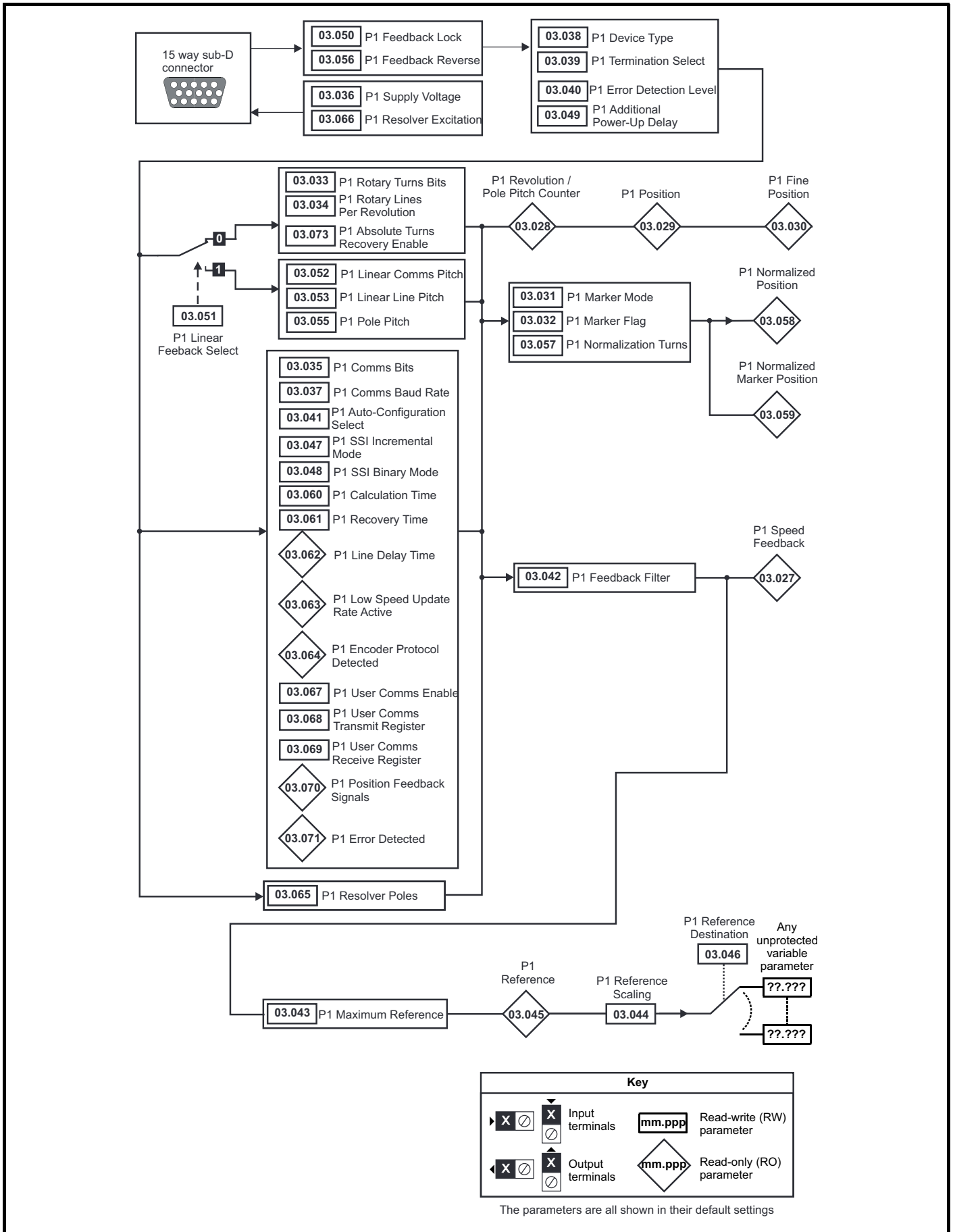


**NOTE**

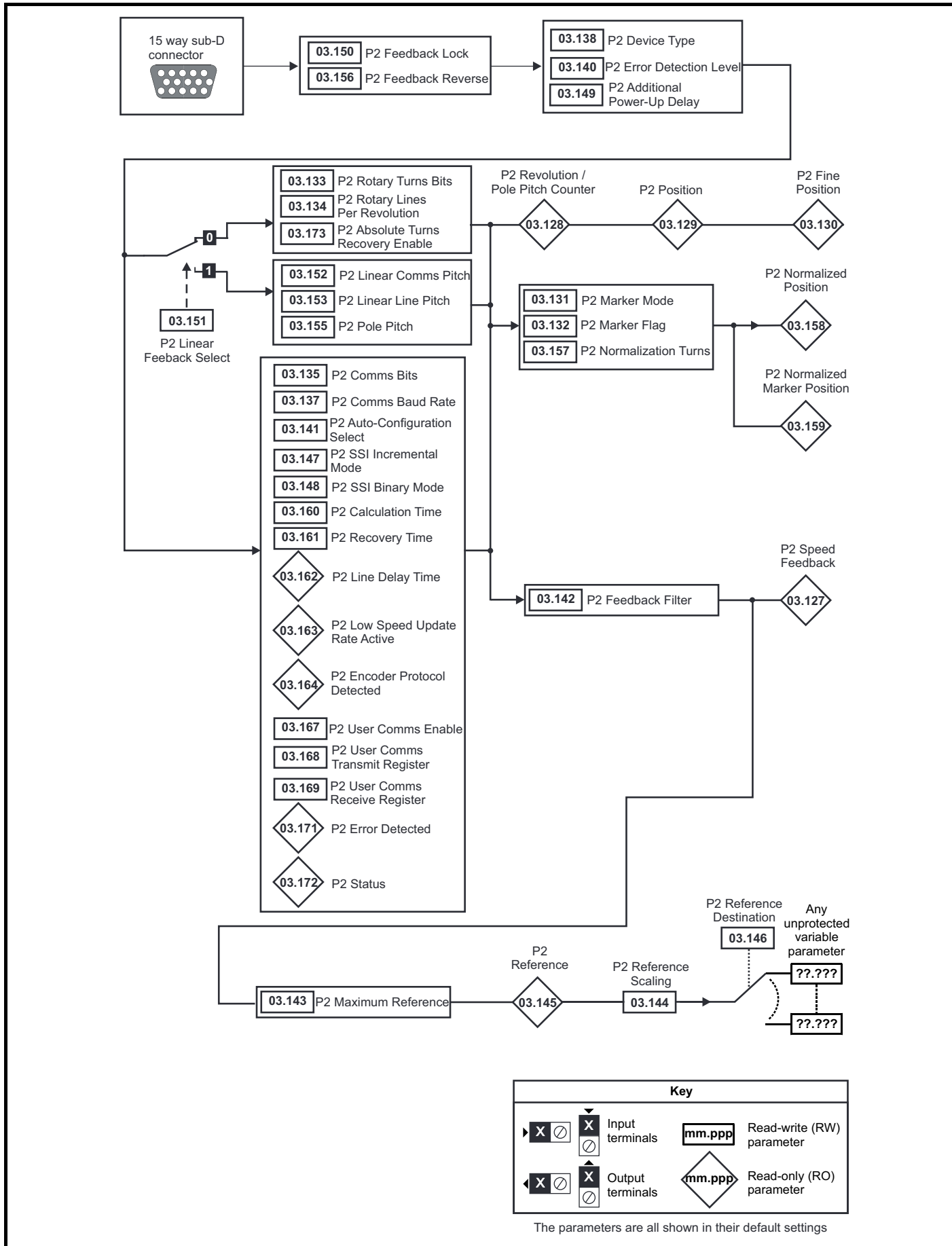
\* Automatic change over if the relevant 'bit' of *Position Feedback Initialized* (03.076) is 0.



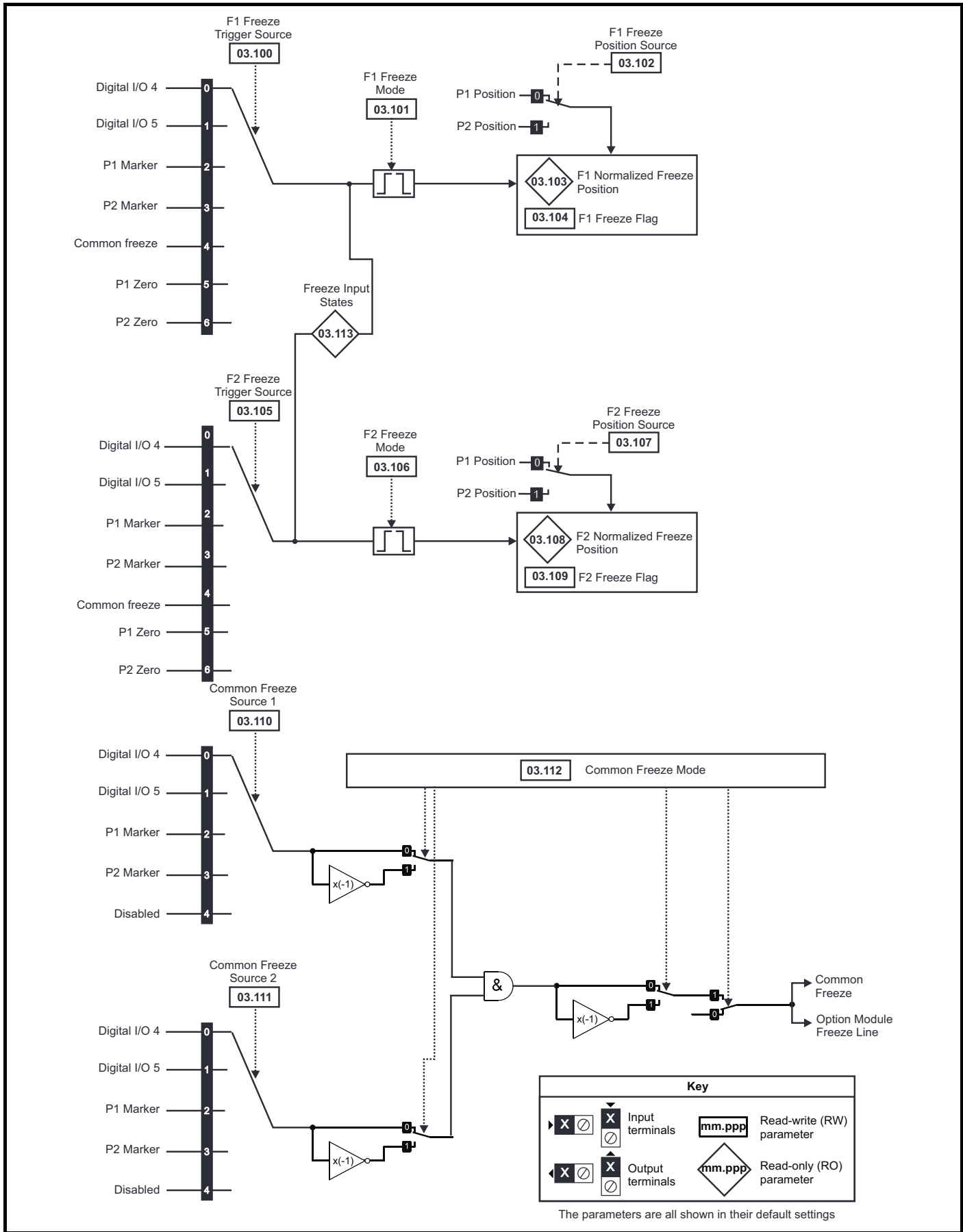
**Figure 12-5 P1 Interface**



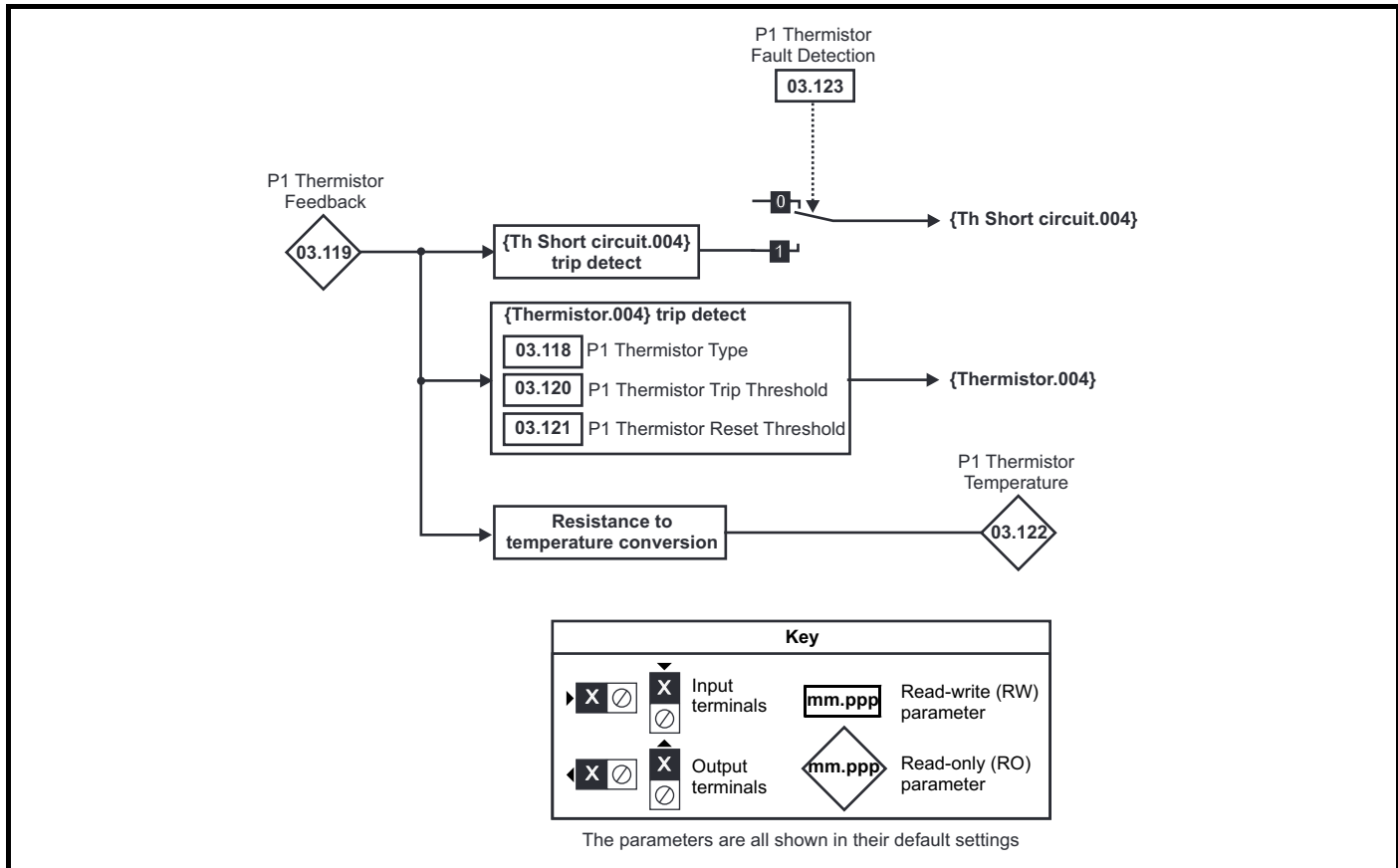
**Figure 12-6 P2 Interface**



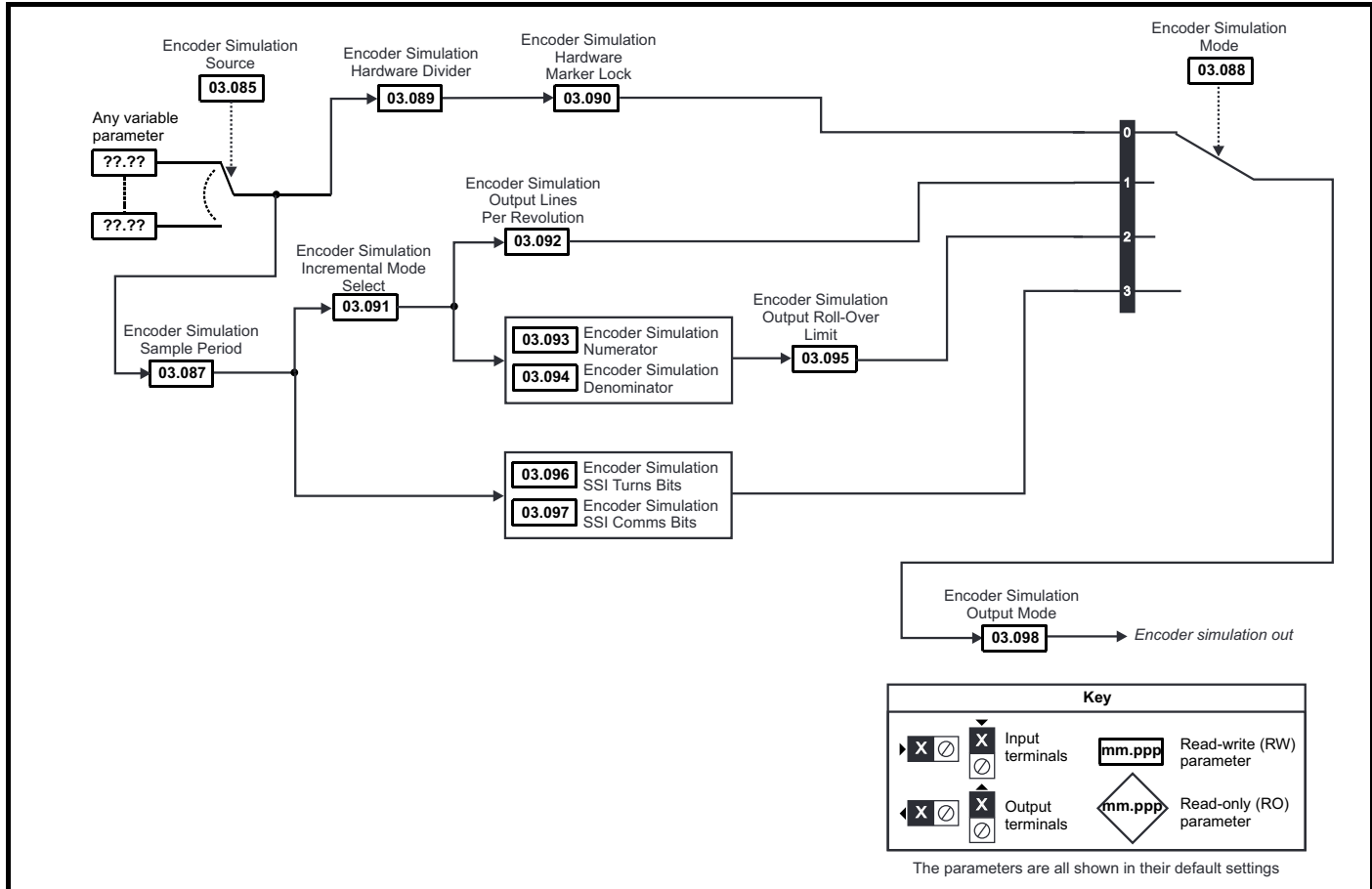
**Figure 12-7 Freeze system logic**



**Figure 12-8 P1 Position feedback interface thermistor input**



**Figure 12-9 Encoder simulation**



Parameter	Range			Default			Type					
	OL	RFC-A	RFC-S	OL	RFC-A	RFC-S	RO	Num	ND	NC	PT	FI
03.001	Open-loop> Frequency Slaving Demand	±1000.0 Hz					RO	Num	ND	NC	PT	FI
	RFC> Final Speed Reference		VM_SPEED				RO	Num	ND	NC	PT	FI
03.002	Speed Feedback		VM_SPEED				RO	Num	ND	NC	PT	FI
03.003	Speed Error		VM_SPEED				RO	Num	ND	NC	PT	FI
03.004	Speed Controller Output		VM_TORQUE_CURRENT %				RO	Num	ND	NC	PT	FI
03.005	Zero Speed Threshold	0.0 to 20.0 Hz	0 to 200 rpm	1.0 Hz	5 rpm		RW	Num				US
03.006	At Speed Lower Limit	0.0 to 550.0 Hz	0 to 33,000 rpm	1.0 Hz	5 rpm		RW	Num				US
03.007	At Speed Upper Limit	0.0 to 550.0 Hz	0 to 33,000 rpm	1.0 Hz	5 rpm		RW	Num				US
03.008	Over Speed Threshold	0.0 to 550.0 Hz	0 to 40,000 rpm	0.0 Hz	0 rpm		RW	Num				US
03.009	Absolute At Speed Select	Off (0) or On (1)			Off (0)		RW	Bit				US
03.010	Speed Controller Proportional Gain Kp1		0.0000 to 200.0000 s/rad		0.0300 s/rad	0.0100 s/rad	RW	Num				US
03.011	Speed Controller Integral Gain Ki1		0.00 to 655.35 s²/rad		0.10 s²/rad	1.00 s²/rad	RW	Num				US
03.012	Speed Controller Differential Feedback Gain Kd1		0.00000 to 0.65535 1/rad		0.00000 1/rad		RW	Num				US
03.013	Open-loop> Enable Frequency Slaving	Off (0) or On (1)		Off (0)			RW	Bit				US
	RFC> Speed Controller Proportional Gain Kp2		0.0000 to 200.0000 s/rad		0.0300 s/rad	0.0100 s/rad	RW	Num				US
03.014	Open-loop> Slaving Ratio Numerator	0.000 to 1.000		1.000			RW	Num				US
	RFC> Speed Controller Integral Gain Ki2		0.00 to 655.35 s²/rad		0.10 s²/rad	1.00 s²/rad	RW	Num				US
	Open-loop> Slaving Ratio Denominator	0.001 to 1.000		1.000			RW	Num				US
03.015	RFC> Speed Controller Differential Feedback Gain Kd2		0.00000 to 0.65535 1/rad		0.00000 1/rad		RW	Num				US
03.016	Open-loop> Reference Frame Angle	0 to 65535					RO	Num	ND	NC	PT	
	RFC> Speed Controller Gain Select		Off (0) or On (1)		Off (0)		RW	Bit				US
03.017	Speed Controller Set-up Method		Disabled (0), Bandwidth (1), Comp Angle (2), Kp Gain Times 16 (3), Low Performance (4), Std Performance (5), High Performance (6), First Order (7)		Disabled (0)		RW	Txt				US
03.018	Motor And Load Inertia		0.00000 to 1000.00000 kgm²		0.00000 kgm²		RW	Num				US
03.019	Compliance Angle		0.0 to 360.0°		4.0°		RW	Num				US
03.020	Bandwidth		5 to 1000 Hz		10 Hz		RW	Num				US
03.021	Damping Factor		0.0 to 10.0		1.0		RW	Num				US
03.022	Hard Speed Reference		VM_SPEED_FREQ_REF		0.0		RW	Num				US
03.023	Hard Speed Reference Select		Off (0) or On (1)		Off (0)		RW	Bit				US
03.024	RFC Feedback Mode		Feedback (0), Sensorless (1), Feedback NoMax (2), Sensorless NoMax (3)		Feedback (0)		RW	Txt				US
03.025	Position Feedback Phase Angle		0.0 to 359.9°			0.0°	RW	Num	ND			US
03.026	Motor Control Feedback Select		P1 Drive (0), P2 Drive (1), P1 Slot 1 (2), P2 Slot 1 (3), P1 Slot 2 (4), P2 Slot 2 (5),		P1 Drive (0)		RW	Txt				US
03.027	P1 Speed Feedback		VM_SPEED				RO	Num	ND	NC	PT	FI
03.028	P1 Revolution/Pole Pitch Counter		0 to 65535				RO	Num	ND	NC	PT	PS
03.029	P1 Position		0 to 65535				RO	Num	ND	NC	PT	PS
03.030	P1 Fine Position		0 to 65535				RO	Num	ND	NC	PT	
03.031	P1 Marker Mode		0000 to 1111		0100		RW	Bin				US
03.032	P1 Marker Flag		Off (0) or On (1)		Off (0)		RW	Bit		NC		
03.033	P1 Rotary Turns Bits		0 to 16		16		RW	Num				US
03.034	P1 Rotary Lines Per Revolution		1 to 100000		1024	4096	RW	Num				US
03.035	P1 Comms Bits		0 to 48		0		RW	Num				US
03.036	P1 Supply Voltage		5V (0), 8V (1), 15V (2)		5V (0)		RW	Txt				US
03.037	P1 Comms Baud Rate		100k (0), 200k (1), 300k (2), 400k (3), 500k (4), 1M (5), 1.5M (6), 2M (7), 4M (8)		300k (2)		RW	Txt				US
03.038	P1 Device Type		AB (0), FD (1), FR (2), AB Servo (3), FD Servo (4), FR Servo (5), SC (6), SC Hiperface (7), EnDat (8), SC EnDat (9), SSI (10), SC SSI (11), SC Servo (12), BiSS (13), Resolver (14), SC SC (15), Commutation Only (16), SC BiSS (17)		AB (0)	AB Servo (3)	RW	Txt				US
03.039	P1 Termination Select		0 to 2		1		RW	Num				US
03.040	P1 Error Detection Level		0000 to 1111	0000 0000	0000 0001		RW	Bin				US
03.041	P1 Auto-configuration Select		Disabled (0) or Enabled (1)		Enabled (1)		RW	Txt				US
03.042	P1 Feedback Filter		Disabled (0), 1 (1), 2 (2), 4 (3), 8 (4), 16 (5) ms		Disabled (0)		RW	Txt				US
03.043	P1 Maximum Reference		0 to 33,000 rpm		1500 rpm	3000 rpm	RW	Num				US

Parameter	Range			Default			Type						
	OL	RFC-A	RFC-S	OL	RFC-A	RFC-S							
03.044	P1 Reference Scaling	0.000 to 4.000			1.000			RW	Num				US
03.045	P1 Reference	±100.0 %						RO	Num	ND	NC	PT	FI
03.046	P1 Reference destination	0.000 to 59.999			0.000			RW	Num	DE		PT	US
03.047	P1 SSI Incremental Mode	Off (0) or On (1)			Off (0)			RW	Bit				US
03.048	P1 SSI Binary Mode	Off (0) or On (1)			Off (0)			RW	Bit				US
03.049	P1 Additional Power-up Delay	0.0 to 25.0 s			0.0 s			RW	Num				US
03.050	P1 Feedback Lock	Off (0) or On (1)			Off (0)			RW	Bit				US
03.051	P1 Linear Feedback Select	Off (0) or On (1)			Off (0)			RW	Bit				US
03.052	P1 Linear Comms Pitch	0.001 to 100.000			0.001			RW	Num				US
03.053	P1 Linear Line Pitch	0.001 to 100.000			0.001			RW	Num				US
03.054	P1 Linear Comms And Line Pitch Units	millimetres (0) or micrometres (1)			millimetres (0)			RW	Txt				US
03.055	P1 Pole Pitch	0.01 to 1000.00 mm			10.00 mm			RW	Num				US
03.056	P1 Feedback Reverse	Off (0) or On (1)			Off (0)			RW	Bit				US
03.057	P1 Normalization Turns	0 to 16			16			RW	Num				US
03.058	P1 Normalized Position	-2147483648 to 2147483647						RO	Num	ND	NC	PT	
03.059	P1 Normalized Marker Position	-2147483648 to 2147483647						RO	Num	ND	NC	PT	
03.060	P1 Calculation Time	0 to 20 µs			5 µs			RW	Num				US
03.061	P1 Recovery Time	5 to 100 µs			30 µs			RW	Num				US
03.062	P1 Line Delay Time	0 to 5000 ns						RO	Num	ND	NC	PT	US
03.063	P1 Low Speed Update Rate Active	Off (0) or On (1)						RO	Bit	ND	NC	PT	
03.064	P1 Encoder Protocol Detected	None (0), Hiperface (1), EnDat 2.1 (2), EnDat 2.2 (3)						RO	Txt	ND	NC	PT	
03.065	P1 Resolver Poles	2 Poles (1) to 20 Poles (10)			2 Poles (1)			RW					US
03.066	P1 Resolver Excitation	6kHz 3V (0), 8kHz 3V (1), 6kHz 2V (2), 8kHz 2V (3), 6kHz Fast (4), 8kHz Fast (5), 6kHz 2V Fast (6), 8kHz 2V Fast (7)			6kHz 3V (0)		6kHz 3V Fast (4)	RW	Txt				US
03.067	P1 User Comms Enable	0 to 1			0			RW	Num		NC	PT	
03.068	P1 User Comms Transmit Register	0 to 65535			0			RW	Num		NC	PT	
03.069	P1 User Comms Receive Register	0 to 65535			0			RW	Num		NC	PT	
03.070	P1 Position Feedback Signals	000000 to 111111						RO	Bin	ND	NC	PT	
03.071	P1 Error Detected	Off (0) or On (1)						RO	Bit	ND	NC	PT	
03.073	P1 Absolute Turns Recovery Enable	Off (0) or On (1)			Off (0)			RW	Bit				US
03.074	P1 Additional Configuration	0 to 511116116			0			RW					
03.075	Initialise Position Feedback	Off (0) or On (1)			Off (0)			RW	Bit		NC		
03.076	Position Feedback Initialized	0000000000 to 1111111111			0000000000			RO	Bin		NC	PT	
03.078	Sensorless Mode Active	Off (0) or On (1)						RO	Bit	ND	NC	PT	
03.079	Sensorless Mode Filter	4 (0), 8 (1), 16 (2), 32 (3), 64 (4) ms			4 (0) ms		64 (4) ms	RW	Txt				US
03.080	Sensorless Position	-2147483648 to 2147483647						RO	Num	ND	NC	PT	
03.085	Encoder Simulation Source	0.000 to 59.999			3.016		0.000	RW	Num			PT	US
03.086	Encoder Simulation Status	None (0), Full (1), No Marker Pulse (2)						RO	Txt	ND	NC	PT	
03.087	Encoder Simulation Sample Period	0.25 (0), 1 (1), 4, (2), 16 (3) ms			4 (2) ms		0.25 (0) ms	RW	Txt				US
03.088	Encoder Simulation Mode	Hardware (0), Lines Per Rev (1), Ratio (2), SSI (3)			Lines Per Rev (1)		Hardware (0)	RW	Txt				US
03.089	Encoder Simulation Hardware Divider	0 to 7			0			RW	Num				US
03.090	Encoder Simulation Hardware Marker Lock	Off (0) or On (1)			Off (0)			RW	Bit				US
03.091	Encoder Simulation Incremental Mode Select	Off (0) or On (1)			On (1)		Off (0)	RW	Bit				US
03.092	Encoder Simulation Output Lines Per Revolution	1 to 16384			1024		4096	RW	Num				US
03.093	Encoder Simulation Numerator	1 to 65536			65536			RW	Num				US
03.094	Encoder Simulation Denominator	1 to 65536			65536			RW	Num				US
03.095	Encoder Simulation Output Roll-over Limit	1 to 65535			65535			RW	Num				US
03.096	Encoder Simulation SSI Turns Bits	0 to 16			16			RW	Num				US
03.097	Encoder Simulation SSI Comms Bits	2 to 48			33			RW	Num				US
03.098	Encoder Simulation Output Mode	AB/Gray (0), FD/Binary (1), FR/Binary (2)			AB/Gray (0)			RW	Txt				US
03.100	F1 Freeze Trigger Source	Digital Input 4 (0), Digital Input 5 (1), P1 Marker (2), P2 Marker (3), Common (4), P1 Zero (5), P2 Zero (6)			Digital Input 4 (0)			RW	Txt				US
03.101	F1 Freeze Mode	Rising 1st (0), Falling 1st (1), Rising all (2), Falling all (3)			Rising 1st (0)			RW	Txt				US
03.102	F1 Freeze Position Source	P1 (0), P2 (1), Time (2)			P1 (0)			RW	Txt				US
03.103	F1 Normalized Freeze Position	-2147483648 to 2147483647						RO	Num	ND	NC	PT	
03.104	F1 Freeze Flag	Off (0) or On (1)			Off (0)			RW	Bit	ND	NC	PT	

Parameter	Range			Default			Type						
	OL	RFC-A	RFC-S	OL	RFC-A	RFC-S							
03.105	F2 Freeze Trigger Source	Digital Input 4 (0), Digital Input 5 (1), P1 Marker (2), P2 Marker (3), Common (4), P1 Zero (5), P2 Zero (6)			Digital Input 4 (0)			RW	Txt				US
03.106	F2 Freeze Mode	Rising 1st (0), Falling 1st (1), Rising all (2), Falling all (3)			Rising 1st (0)			RW	Txt				US
03.107	F2 Freeze Position Source	P1 (0), P2 (1), Time (2)			P1 (0)			RW	Txt				US
03.108	F2 Normalized Freeze Position	-2147483648 to 2147483647						RO	Num	ND	NC	PT	
03.109	F2 Freeze Flag	Off (0) or On (1)			Off (0)			RW	Bit	ND	NC	PT	
03.110	Common Freeze Source 1	Digital Input 4 (0), Digital Input 5 (1), P1 Marker (2), P2 Marker (3), Disabled (4)			Digital Input 4 (0)			RW	Txt				US
03.111	Common Freeze Source 2	Digital Input 4 (0), Digital Input 5 (1), P1 Marker (2), P2 Marker (3), Disabled (4)			Digital Input 4 (0)			RW	Txt				US
03.112	Common Freeze Mode	0000 to 1111			0000			RW	Bin				US
03.113	Freeze Input States	00 to 11						RO	Bin	ND	NC	PT	
03.118	P1 Thermistor Type	DIN44082 (0), KTY84 (1), 0.8mA (2), Encoder (3)			DIN44082 (0)			RW	Txt				US
03.119	P1 Thermistor Feedback	0 to 5000 Ω						RO	Num	ND	NC	PT	
03.120	P1 Thermistor Trip Threshold	0 to 5000 Ω			3300 Ω			RW	Num				US
03.121	P1 Thermistor Reset Threshold	0 to 5000 Ω			1800 Ω			RW	Num				US
03.122	P1 Thermistor Temperature	-50 to 300 °C						RO	Num	ND	NC	PT	
03.123	P1 Thermistor Fault Detection	None (0), Temperature (1), Temp or Short (2)			None (0)		Temperature	RW	Txt				US
03.127	P2 Speed Feedback	±VM_SPEED						RO	Num	ND	NC	PT	FI
03.128	P2 Revolution/Pole Pitch Counter	0 to 65535						RO	Num	ND	NC	PT	PS
03.129	P2 Position	0 to 65535						RO	Num	ND	NC	PT	PS
03.130	P2 Fine Position	0 to 65535						RO	Num	ND	NC	PT	
03.131	P2 Marker Mode	0000 to 1111			0100			RW	Bin				US
03.132	P2 Marker Flag	Off (0) or On (1)			Off (0)			RW	Bit		NC		
03.133	P2 Rotary Turns Bits	0 to 16			16			RW	Num				US
03.134	P2 Rotary Lines Per Revolution	0 to 100000			1024		4096	RW	Num				US
03.135	P2 Comms Bits	0 to 48			0			RW	Num				US
03.137	P2 Comms Baud Rate	100k (0), 200k (1), 300k (2), 400k (3), 500k (4), 1M (5), 1.5M (6), 2M (7), 4M (8) Baud			300k (2) Baud			RW	Txt				US
03.138	P2 Device type	None (0), AB (1), FD (2), FR (3), EnDat (4), SSI (5), BiSS (6)			None (0)			RW	Txt				US
03.140	P2 Error Detection Level	0000 to 1111			00001			RW	Bin				US
03.141	P2 Auto-configuration Select	Disabled (0), Enabled (1)			Enabled (1)			RW	Txt				US
03.142	P2 Feedback Filter	Disabled (0), 1 (1), 2 (2), 4 (3), 8 (4), 16 (5) ms			Disabled (0)			RW	Txt				US
03.143	P2 Maximum Reference	0 to 33,000 rpm			1500 rpm		3000 rpm	RW	Num				US
03.144	P2 Reference Scaling	0.000 to 4.000			1.000			RW	Num				US
03.145	P2 Reference	±100.0 %						RO	Num	ND	NC	PT	FI
03.146	P2 Reference Destination	0.000 to 59.999			0.000			RW	Num	DE		PT	US
03.147	P2 SSI Incremental Mode	Off (0) or On (1)			Off (0)			RW	Bit				US
03.148	P2 SSI Binary Mode	Off (0) or On (1)			Off (0)			RW	Bit				US
03.149	P2 Additional Power-up Delay	0.0 to 25.0 s			0.0 s			RW	Num				US
03.150	P2 Feedback Lock	Off (0) or On (1)			Off (0)			RW	Bit				US
03.151	P2 Linear Feedback Select	Off (0) or On (1)			Off (0)			RW	Bit				US
03.152	P2 Linear Comms Pitch	0.001 to 100.000			0.001			RW	Num				US
03.153	P2 Linear Line Pitch	0.001 to 100.000			0.001			RW	Num				US
03.154	P2 Linear Comms And Line Pitch Units	Millimetres (0) or Micrometres (1)			Millimetres (0)			RW	Txt				US
03.155	P2 Pole Pitch	0.01 to 1000.00 mm			10.00 mm			RW	Num				US
03.156	P2 Feedback Reverse	Off (0) or On (1)			Off (0)			RW	Bit				US
03.157	P2 Normalization Turns	0 to 16			16			RW	Num				US
03.158	P2 Normalized Position	-2147483648 to 2147483647						RO	Num	ND	NC	PT	
03.159	P2 Normalized Marker Position	-2147483648 to 2147483647						RO	Num	ND	NC	PT	
03.160	P2 Calculation Time	0 to 20 μs			5 μs			RW	Num				US
03.161	P2 Recovery Time	5 to 100 μs			30 μs			RW	Num				US
03.162	P2 Line Delay Time	0 to 5000 ns						RO	Num	ND	NC	PT	US
03.163	P2 Low Speed Update Rate Active	Off (0) or On (1)						RO	Bit	ND	NC	PT	
03.164	P2 Encoder Protocol Detected	None (0), Hiperface (1), EnDat 2.1 (2), EnDat 2.2 (3), BiSS (4)						RO	Txt	ND	NC	PT	
03.167	P2 User Comms Enable	0 to 1			0			RW	Num		NC	PT	
03.168	P2 User Comms Transmit Register	0 to 65535			0			RW	Num		NC	PT	
03.169	P2 User Comms Receive Register	0 to 65535			0			RW	Num		NC	PT	
03.171	P2 Error Detected	Off (0) or On (1)						RO	Bit	ND	NC	PT	

Safety information	Product information	Mechanical installation	Electrical installation	Getting started	Basic parameters	Running the motor	Optimization	Drive communication	SD Card Operation	Onboard PLC	<b>Advanced parameters</b>	Diagnostics	UL listing information
--------------------	---------------------	-------------------------	-------------------------	-----------------	------------------	-------------------	--------------	---------------------	-------------------	-------------	----------------------------	-------------	------------------------

Parameter		Range			Default			Type					
		OL	RFC-A	RFC-S	OL	RFC-A	RFC-S	RO	Txt	ND	NC	PT	US
03.172	P2 Status	None (0), AB (1), FD (2), FR (3), EnDat (4), SSI (5), BiSS (6), EnDat Alt (7), SSI Alt (8), BiSS Alt (9)						RO	Txt	ND	NC	PT	
03.173	P2 Absolute Turns Recovery Enable	Off (0) or On (1)			Off (0)			RW	Bit				US
03.174	P1 Additional Configuration	0 to 511116116			0			RW					

RW	Read / Write	RO	Read only	Num	Number parameter	Bit	Bit parameter	Txt	Text string	Bin	Binary parameter	FI	Filtered
ND	No default value	NC	Not copied	PT	Protected parameter	RA	Rating dependent	US	User save	PS	Power-down save	DE	Destination

## 12.5 Menu 4: Torque and current control

Figure 12-10 Menu 4 Open loop logic diagram

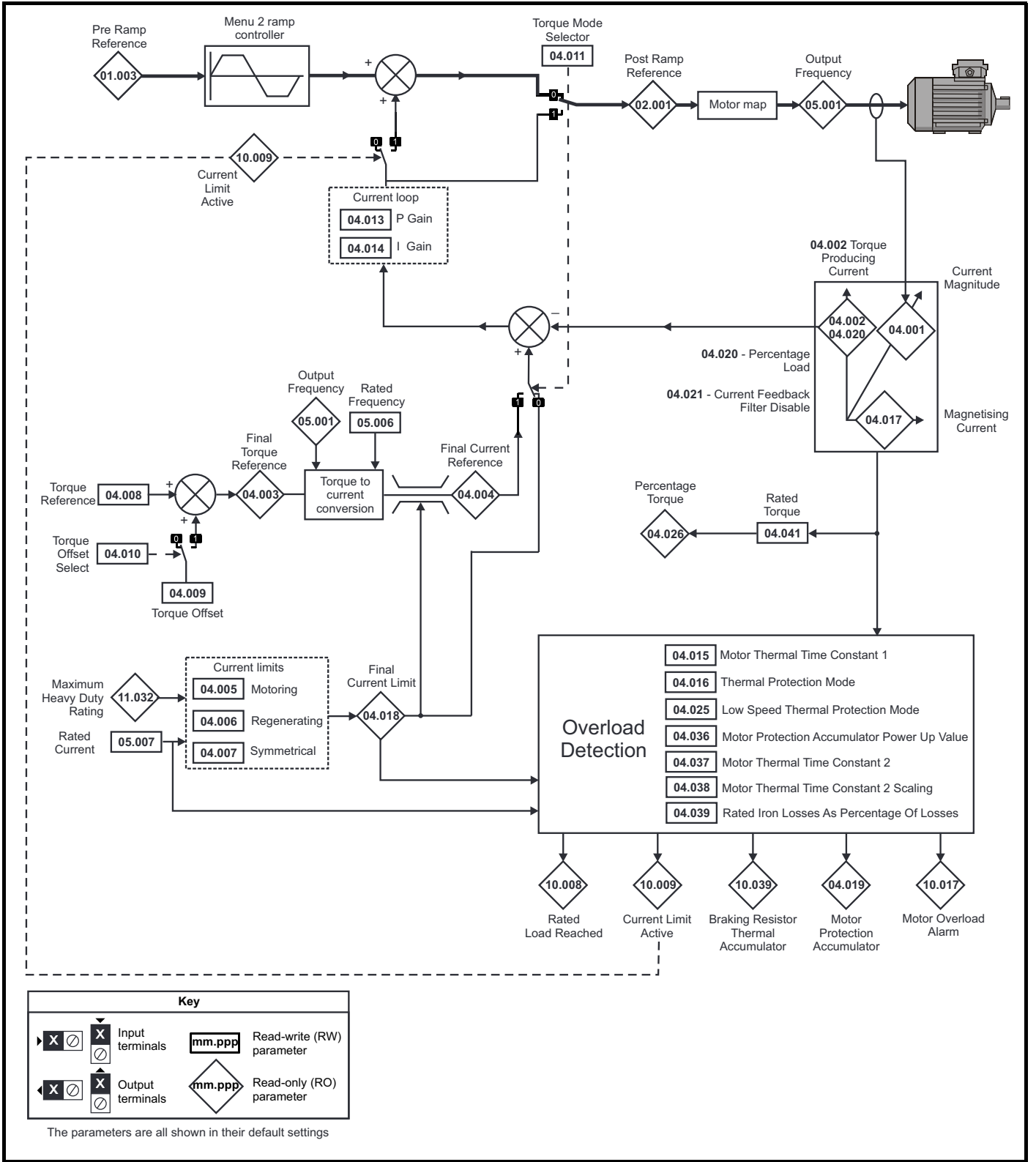


Figure 12-11 Menu 4 RFC-A logic diagram

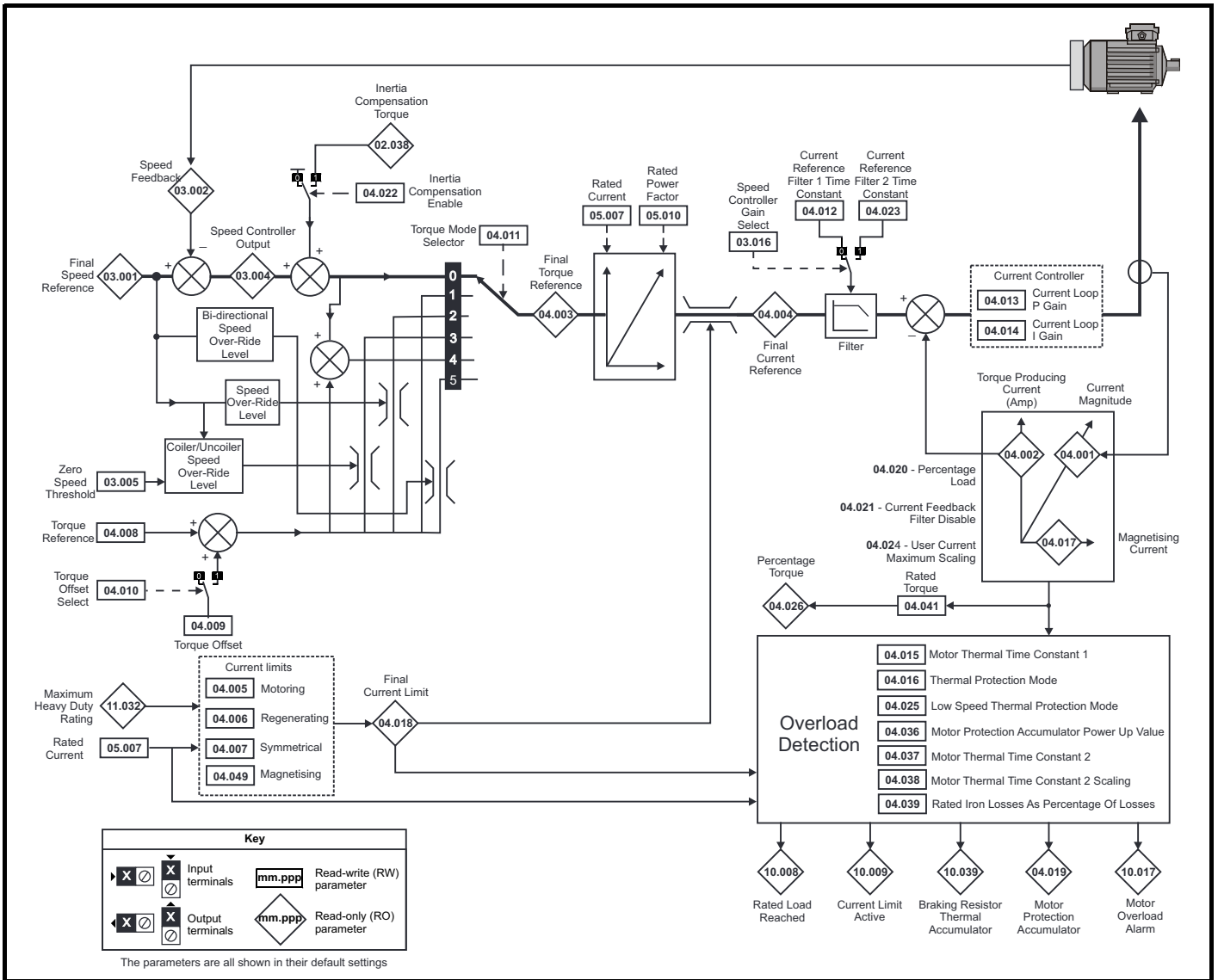
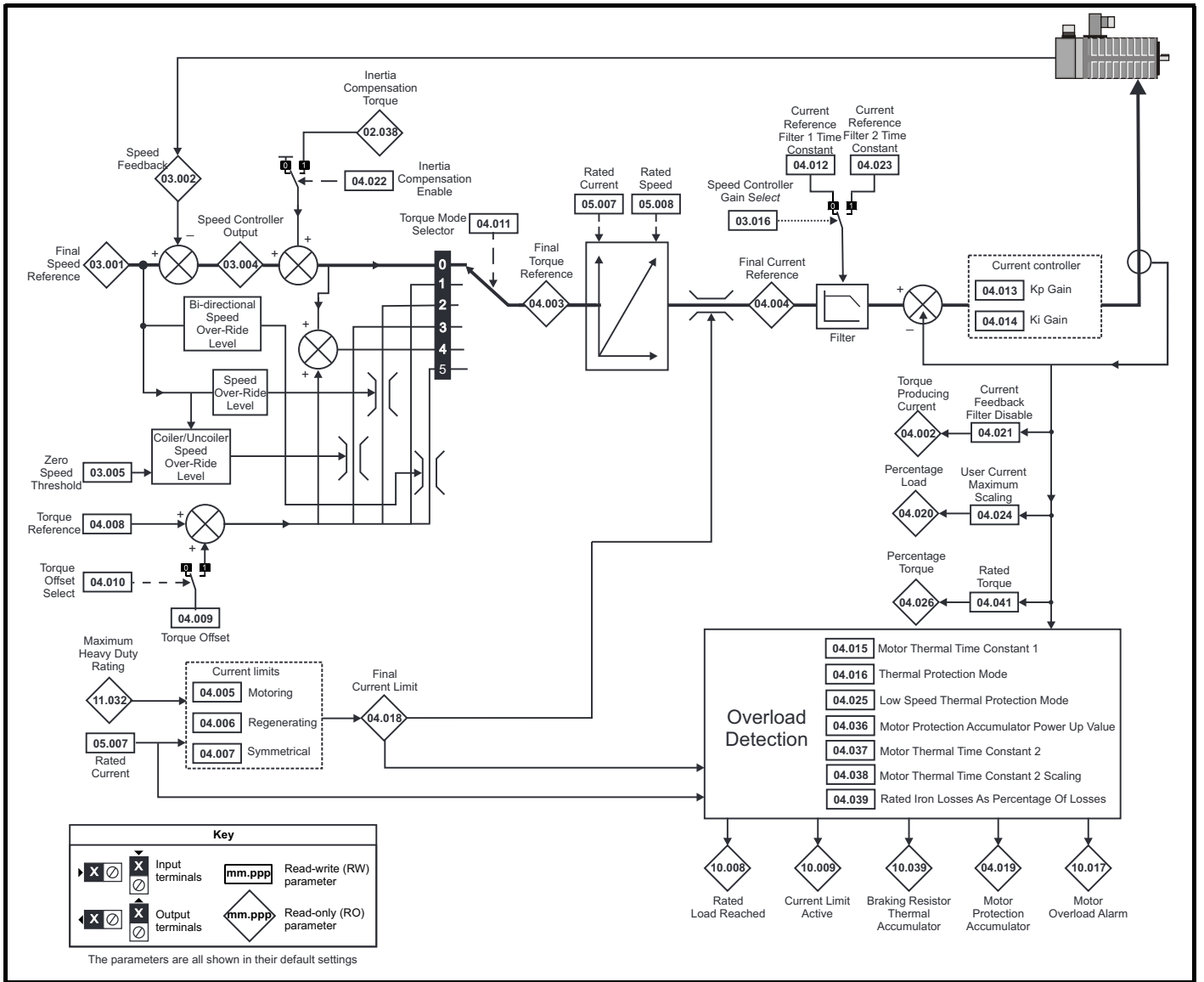


Figure 12-12 Menu 4 RFC-S logic diagram



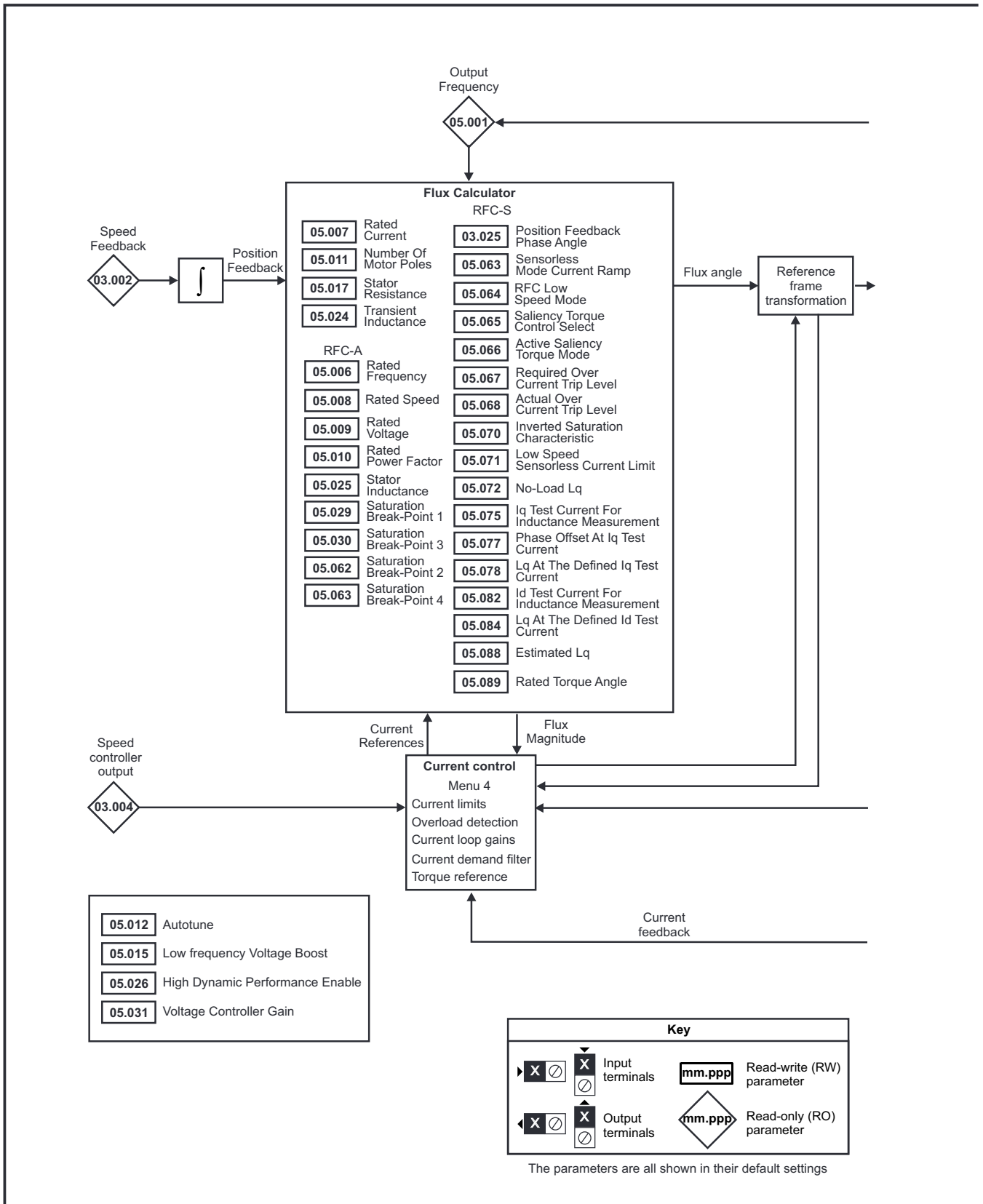
Parameter		Range(⇅)		Default(⇄)			Type					
		OL	RFC-A / S	OL	RFC-A	RFC-S						
04.001	Current Magnitude	0.000 to VM_DRIVE_CURRENT_UNIPOLAR A					RO	Num	ND	NC	PT	FI
04.002	Torque Producing Current / Iq	VM_DRIVE_CURRENT A					RO	Num	ND	NC	PT	FI
04.003	Final Torque Reference	VM_TORQUE_CURRENT %					RO	Num	ND	NC	PT	FI
04.004	Final Current Reference	VM_TORQUE_CURRENT %					RO	Num	ND	NC	PT	FI
04.005	Motoring Current Limit	0.0 to VM_MOTOR1_CURRENT_LIMIT %		165.0 %		250.0 %	RW	Num		RA		US
04.006	Regenerating Current Limit	0.0 to VM_MOTOR1_CURRENT_LIMIT %		165.0 %		250.0 %	RW	Num		RA		US
04.007	Symmetrical Current Limit	0.0 to VM_MOTOR1_CURRENT_LIMIT %		165.0 %		250.0 %	RW	Num		RA		US
04.008	Torque Reference	VM_USER_CURRENT_HIGH_RES %				0.00 %	RW	Num				US
04.009	Torque Offset	VM_USER_CURRENT %				0.0 %	RW	Num				US
04.010	Torque Offset Select	Off (0) or On (1)				Off (0)	RW	Bit				US
04.011	Torque Mode Selector	0 to 1	0 to 5			0	RW	Num				US
04.012	Current Reference Filter 1 Time Constant		0.0 to 25.0 ms			0.0 ms	RW	Num				US
04.013	Current Controller Kp Gain	0 to 30000		20		150	RW	Num				US
04.014	Current Controller Ki Gain	0 to 30000		40		2000	RW	Num				US
04.015	Motor Thermal Time Constant 1	1.0 to 3000.0 s				89.0 s	RW	Num				US
04.016	Thermal Protection Mode	Motor Trip (0), Motor Current Limit (1), Drive Current Limit (2), Motor and Drive Current Limit (3), Disabled (4)				Motor Trip (0)	RW	Bin				US
04.017	Magnetising Current / Id	VM_DRIVE_CURRENT A					RO	Num	ND	NC	PT	FI
04.018	Final Current Limit	VM_TORQUE_CURRENT %					RO	Num	ND	NC	PT	
04.019	Motor Protection Accumulator	0.0 to 100.0 %					RO	Num	ND	NC	PT	PS
04.020	Percentage Load	VM_USER_CURRENT %					RO	Num	ND	NC	PT	FI
04.021	Current Feedback Filter Disable	Off (0) or On (1)				Off (0)	RW	Bit				US
04.022	Inertia Compensation Enable		Off (0) or On (1)			Off (0)	RW	Bit				US
04.023	Current Reference Filter 2 Time Constant		0.0 to 25.0 ms			0.0 ms	RW	Num				US
04.024	User Current Maximum Scaling	0.0 to VM_TORQUE_CURRENT_UNIPOLAR %		165.0 %		300.0 %	RW	Num		RA		US
04.025	Low Speed Thermal Protection Mode	0 to 1				0	RW	Num				US
04.026	Percentage Torque	VM_USER_CURRENT %					RO	Num	ND	NC	PT	FI
04.030	Current Controller Mode		Off (0) or On (1)			Off (0)	RW	Bit				US
04.031	Notch Filter Centre Frequency		50 to 1000 Hz			100 Hz	RW	Num				US
04.032	Notch Filter Bandwidth		0 to 500 Hz			0 Hz	RW	Num				US
04.033	Inertia Times 1000		Off (0) or On (1)			Off (0)	RW	Bit				US
04.036	Motor Protection Accumulator Power-up Value	Power down (0), Zero (1), Real time (2)				Power down (0)	RW	Txt				US
04.037	Motor Thermal Time Constant 2	1.0 to 3000.0 s				89.0 s	RW	Num				US
04.038	Motor Thermal Time Constant 2 Scaling	0 to 100 %				0 %	RW	Num				US
04.039	Rated Iron Losses As Percentage Of Losses	0 to 100 %				0 %	RW	Num				US
04.041	Rated Torque	0.00 to 50000.00 N m				0.00 N m	RW	Num				US
04.042	Torque Estimation Minimum Frequency	0 to 100 %				5 %	RW	Num				US
04.043	Torque Correction Time Constant		0.00 to 10.00 s			0.00 s	RW	Num				US
04.044	Torque Correction Maximum		0 to 100 %			20 %	RW	Num				US
04.045	No-load Core Loss	0.000 to 99999.999 kW				0.000 kW	RW	Num				US
04.046	Rated Core Loss	0.000 to 99999.999 kW				0.000 kW	RW	Num				US
04.049	Magnetising Current Limit		0.0 to 100.0 %			100.0 %	RW	Num				US

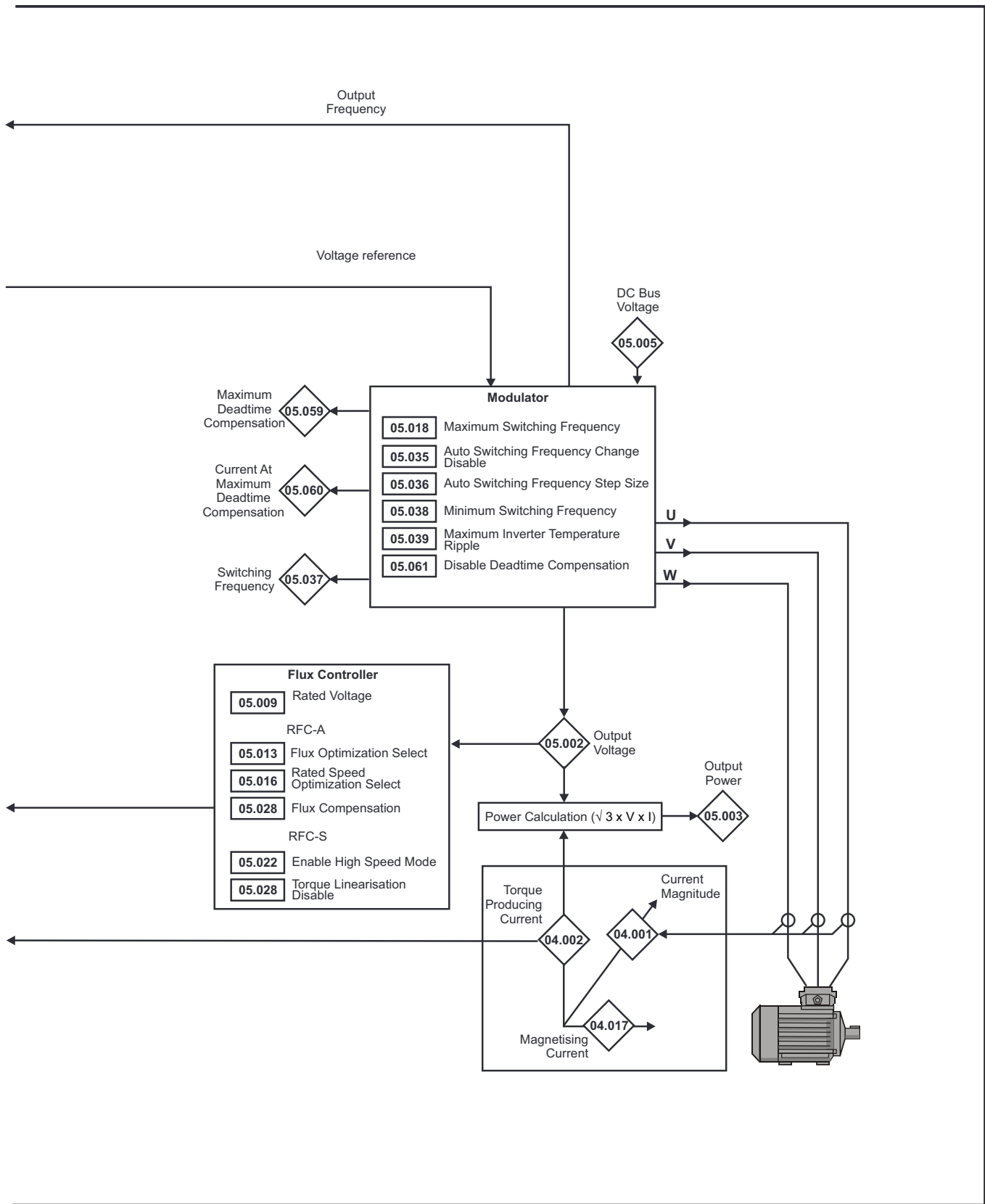
RW	Read / Write	RO	Read only	Num	Number parameter	Bit	Bit parameter	Txt	Text string	Bin	Binary parameter	FI	Filtered
ND	No default value	NC	Not copied	PT	Protected parameter	RA	Rating dependent	US	User save	PS	Power-down save	DE	Destination



Safety information	Product information	Mechanical installation	Electrical installation	Getting started	Basic parameters	Running the motor	Optimization	Drive communication	SD Card Operation	Onboard PLC	<b>Advanced parameters</b>	Diagnostics	UL listing information
--------------------	---------------------	-------------------------	-------------------------	-----------------	------------------	-------------------	--------------	---------------------	-------------------	-------------	----------------------------	-------------	------------------------

Figure 12-14 Menu 5 RFC-A, RFC-S logic diagram





Parameter	Range(⌘)			Default(⇄)			Type						
	OL	RFC-A	RFC-S	OL	RFC-A	RFC-S							
05.001	Output Frequency	VM_SPEED FREQ_REF	±2000.0 Hz					RO	Num	ND	NC	PT	FI
05.002	Output Voltage	0 to VM_AC_VOLTAGE V						RO	Num	ND	NC	PT	FI
05.003	Output Power	VM_POWER kW						RO	Num	ND	NC	PT	FI
05.004	Motor Rpm	±180000 rpm						RO	Num	ND	NC	PT	FI
05.005	D.c. Bus Voltage	0 to VM_DC_VOLTAGE V						RO	Num	ND	NC	PT	FI
05.006	Rated Frequency	0.0 to 550.0 Hz			50Hz: 50.0 60Hz: 60.0		RW	Num					US
05.007	Rated Current	0.000 to VM_RATED_CURRENT A			Maximum Heavy Duty Rating (11.032)			RW	Num		RA		US
05.008	Rated Speed	0 to 33000 rpm	0.00 to 33000.00 rpm		50Hz: 1500 rpm 60Hz: 1800 rpm	50Hz: 1450.00 rpm 60Hz: 1750.00 rpm	3000.00 rpm	RW	Num				US
05.009	Rated Voltage	0 to VM_AC_VOLTAGE_SET			200 V drive: 230 V 50 Hz - 400 V drive: 400 V 60 Hz - 400 V drive: 460 V 575 V drive: 575 V 690 V drive: 690 V			RW	Num		RA		US
05.010	Rated Power Factor	0.000 to 1.000			0.850		RW	Num		RA			US
05.011	Number Of Motor Poles	Automatic (0) to 480 Poles (240)			Automatic (0)		6 Poles (3)	RW	Num				US
05.012	Autotune	0 to 2	0 to 4	0 to 5	0			RW	Num		NC		US
05.013	Open loop: Dynamic V To F Select	Off (0) or On (1)			Off (0)			RW	Bit				US
	RFC-A: Flux Optimization Select	Off (0) or On (1)			Off (0)			RW	Bit				US
	RFC-S: Minimal movement phasing test mode			Free x4 (-3), Free x3 (-2), Free x2 (-1), Free (0), Constrained (1)	Free (0)			RW	Txt				US
05.014	Open loop: Open-loop Control Mode	Ur S (0), Ur (1), Fixed (2), Ur Auto (3), Ur I (4), Square (5),			Ur I (4)			RW	Txt				US
	RFC-S: Phasing Test On Enable			Disabled (0), Short (1), Short Once (2), Long (3), Long Once (4)	Disabled (0)			RW	Txt				US
05.015	Low Frequency Voltage Boost	0.0 to 25.0 %			1 %			RW	Num				US
	Minimal Movement Phasing Test Current			1 % (0), 2 % (1), 3 % (2), 6 % (3), 12 % (4), 25 % (5), 50 % (6), 100 % (7)	1 % (0)			RW	Txt				US
05.016	Rated Speed Optimization Select	Disabled (0), Classic Slow (1), Classic Fast (2), Combined (3), VARs Only (4), Voltage Only (5)			Disabled (0)			RW	Txt				US
	Minimal Movement Phasing Test Angle			0.00 to 25.00°	0.00°			RW	Num				US
05.017	Stator Resistance	0.000000 to 1000.000000 Ω			0.000000 Ω			RW	Num		RA		US
05.018	Maximum Switching Frequency	2 kHz (0), 3 kHz (1), 4 kHz (2), 6 kHz (3), 8 kHz (4), 12 kHz (5), 16 kHz (6)			8 kHz (4)			RW	Txt		RA		US
05.019	High Stability Space Vector Modulation	Off (0) or On (1)			Off (0)			RW	Bit				US
	Rated Speed Optimization Minimum Frequency		0 to 100 %		10 %		-180°	RW	Num				US
05.020	Quasi-square Enable	Off (0) or On (1)			Off (0)			RW	Bit				US
	Rated Speed Optimization Minimum Load		0 to 100 %		50 %			RW	Num				US
05.021	Mechanical Load Test Level	0 to 100 %			0 %			RW	Num				US
05.022	Enable High Speed Mode			Limit (-2), Limit (Servo) (-1), Disable (0), Enable (Servo) (1), Enable (2)	Disable (0)			RW	Txt				US
05.024	Transient Inductance	0.000 to 500.000 mH			0.000 mH			RW	Num		RA		US
	Ld			0.000 to 500.000 mH	0.000 mH			RW	Num		RA		US
05.025	Stator Inductance	0.00 to 5000.00 mH			0.00 mH			RW	Num		RA		US
05.026	High Dynamic Performance Enable	Off (0) or On (1)			Off (0)			RW	Bit				US
05.027	Enable Slip Compensation	Off (0) or On (1)			On (1)			RW	Bit				US
	Flux Control Gain			0.1 to 10.0	1.0		1.0	RW	Num				US

Parameter	Range(↕)			Default(⇔)			Type					
	OL	RFC-A	RFC-S	OL	RFC-A	RFC-S						
05.028	Flux Compensation		0 to 2		0		RW	Num				US
	Torque Linearization Disable			Off (0) or On (1)		On (1)	RW	Bit				US
05.029	Saturation Breakpoint 1		0.0 to 100.0 %		50.0 %		RW	Num				US
05.030	Saturation Breakpoint 3		0.0 to 100.0 %		75.0 %		RW	Num				US
05.031	Voltage Controller Gain		1 to 30		1		RW	Num				US
05.032	Torque Per Amp		0.00 to 500.00 Nm/A				RO	Num	ND	NC	PT	
				0.00 to 500.00 Nm/A		1.60 Nm/A	RW	Num				US
05.033	Volts Per 1000 rpm			0 to 10,000 V		98	RW	Num				US
05.034	Percentage Flux		0.0 to 150.0 %				RO	Num	ND	NC	PT	FI
05.035	Auto-switching Frequency Change Disable	Enabled (0), Disabled (1), No Ripple Detect (2)			Enabled (0)			RW	Txt			US
05.036	Auto-switching Frequency Step Size		1 to 2		2		RW	Num				US
05.037	Switching Frequency		2 kHz (0), 3 kHz (1), 4 kHz (2), 6 kHz (3), 8 kHz (4), 12 kHz (5), 16 kHz (6)				RO	Txt	ND	NC	PT	
05.038	Minimum Switching Frequency		0 to VM_MIN_SWITCHING_FREQUENCY kHz			4 (2) kHz	RW	Txt				US
05.039	Maximum Inverter Temperature Ripple		20 to 60 °C			60 °C	RW	Num				US
05.040	Spin Start Boost		0.0 to 10.0		1.0		RW	Num				US
05.041	Voltage Headroom		0 to 20 %			0 %	RW	Num				US
05.042	Reverse Output Phase Sequence		Off (0) or On (1)			Off (0)	RW	Bit				US
05.044	Stator Temperature Source	User (0), P1 Drive (1), P1 Slot 1 (2), P1 Slot 2 (3), P1 Slot 3 (4), P1 Slot 4 (5)			User (0)			RW	Txt			US
05.045	User Stator Temperature		-50 to 300 °C			0 °C	RW	Num				
05.046	Stator Temperature		-50 to 300 °C				RO	Num	ND	NC	PT	
05.047	Stator Temperature Coefficient		0.00000 to 0.10000 °C <sup>-1</sup>			0.00390 °C <sup>-1</sup>	RW	Num				US
05.048	Stator Base Temperature		-50 to 300 °C			0 °C	RW	Num				US
05.049	Enable Stator Compensation		Off (0) or On (1)			Off (0)	RW	Bit				US
05.050	Temperature Compensated Stator Resistance		0.000000 to 1000.000000 Ω				RO	Num	ND	NC	PT	
05.051	Rotor Temperature Source	User (0), P1 Drive (1), P1 Slot 1 (2), P1 Slot 2 (3), P1 Slot 3 (4), P1 Slot 4 (5)			User (0)			RW	Txt			US
05.052	User Rotor Temperature		-50 to 300 °C			0 °C	RW	Num				US
05.053	Rotor Temperature		-50 to 300 °C				RO	Num	ND	NC	PT	
05.054	Rotor Temperature Coefficient		0.00000 to 0.10000 °C <sup>-1</sup>			0.00390 °C <sup>-1</sup>	RW	Num				US
05.055	Rotor Base Temperature		-50 to 300 °C			0 °C	RW	Num				US
05.056	Enable Rotor Compensation		Off (0) or On (1)			Off (0)	RW	Bit				US
05.057	Temperature compensated rated speed	0.00 to 18000.00 rpm	0.00 to 50000.00 rpm				RO	Num	ND	NC	PT	
	Rotor Temperature Compensation			0.000 to 2.000			RO	Num	ND	NC	PT	
05.059	Maximum Deadtime Compensation		0.000 to 10.000 μs				RO	Num		NC	PT	US
05.060	Current At Maximum Deadtime Compensation		0.00 to 100.00 %				RO	Num		NC	PT	US
05.061	Disable Deadtime Compensation		Off (0) or On (1)			Off (0)	RW	Bit				US
05.062	Saturation Breakpoint 2		0.0 to 100.0 %		0.0 %		RW	Num				US
05.063	Saturation Breakpoint 4		0.0 to 100.0 %		0.0 %		RW	Num				US
05.063	Sensorless Mode Current Ramp			0.00 to 1.00 s		0.20 s	RW	Num				US
05.064	RFC Low Speed Mode			Injection (0), Non-salient (1), Current (2), Current No Test (3)		Current (2)	RW	Txt				US
05.065	Saliency Torque Control Select			Disabled (0), Low (1), High (2), Auto (3)		Disabled (0)	RW	Txt				US
05.066	Active Saliency Torque Mode			Disabled (0), Low (1), High (2)			RO	Txt	ND	NC	PT	
05.067	Required Over-current Trip Level		0 to 100 %			0 %	RW	Num				US
05.068	Actual Over-current Trip Level		0 to 500 %				RO	Num	ND	NC	PT	
05.070	Inverted Saturation Characteristic		Off (0) or On (1)			Off (0)	RW	Bit				US
05.071	Low Speed Sensorless Mode Current Limit		0.0 to 1000.0 %			100.0 %	RW	Num		RA		US
05.072	No-load Lq			0.000 to 500.000 mH		0.000 mH	RW	Num		RA		US
05.075	Iq Test Current For Inductance Measurement		0 to 200 %			100 %	RW	Num				US
05.077	Phase Offset At Iq Test Current		±90.0°			0.0°	RW	Num		RA		US

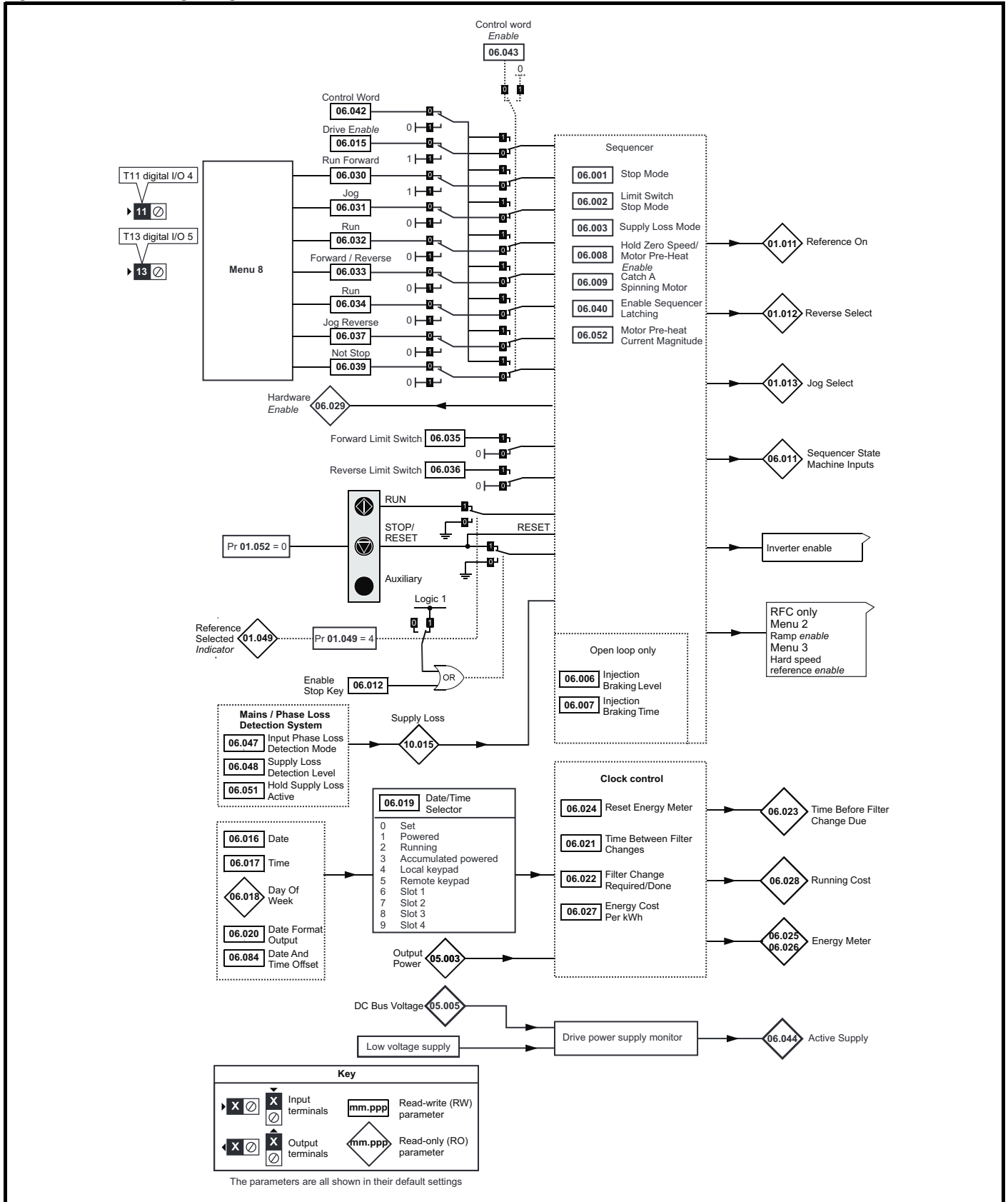
Safety information	Product information	Mechanical installation	Electrical installation	Getting started	Basic parameters	Running the motor	Optimization	Drive communication	SD Card Operation	Onboard PLC	Advanced parameters	Diagnostics	UL listing information
--------------------	---------------------	-------------------------	-------------------------	-----------------	------------------	-------------------	--------------	---------------------	-------------------	-------------	---------------------	-------------	------------------------

Parameter	Range(⇄)			Default(⇒)			Type					
	OL	RFC-A	RFC-S	OL	RFC-A	RFC-S						
05.078	Lq At The Defined Iq Test Current		0.000 to 500.000 mH			0.000 mH	RW	Num		RA		US
05.082	Id Test Current for Inductance Measurement		-100 to 0 %			-100 %	RW	Num				US
05.084	Lq At The Defined Id Test Current		0.000 to 500.000 mH			0.000 mH	RW	Num		RA		US
05.085	Lq Incremental Inductance At Defined Id Current		0.000 to 500.000 mH			0.000 mH	RW	Num		RA		US
05.087	User Defined Rated Torque Angle		0 to 90°			0°	RW	Num				US
05.088	Estimated Lq		0.000 to 500.000 mH				RO	Num	ND	NC	PT	FI
05.089	Rated Torque Angle		0 to 90°				RO	Num	ND	NC	PT	

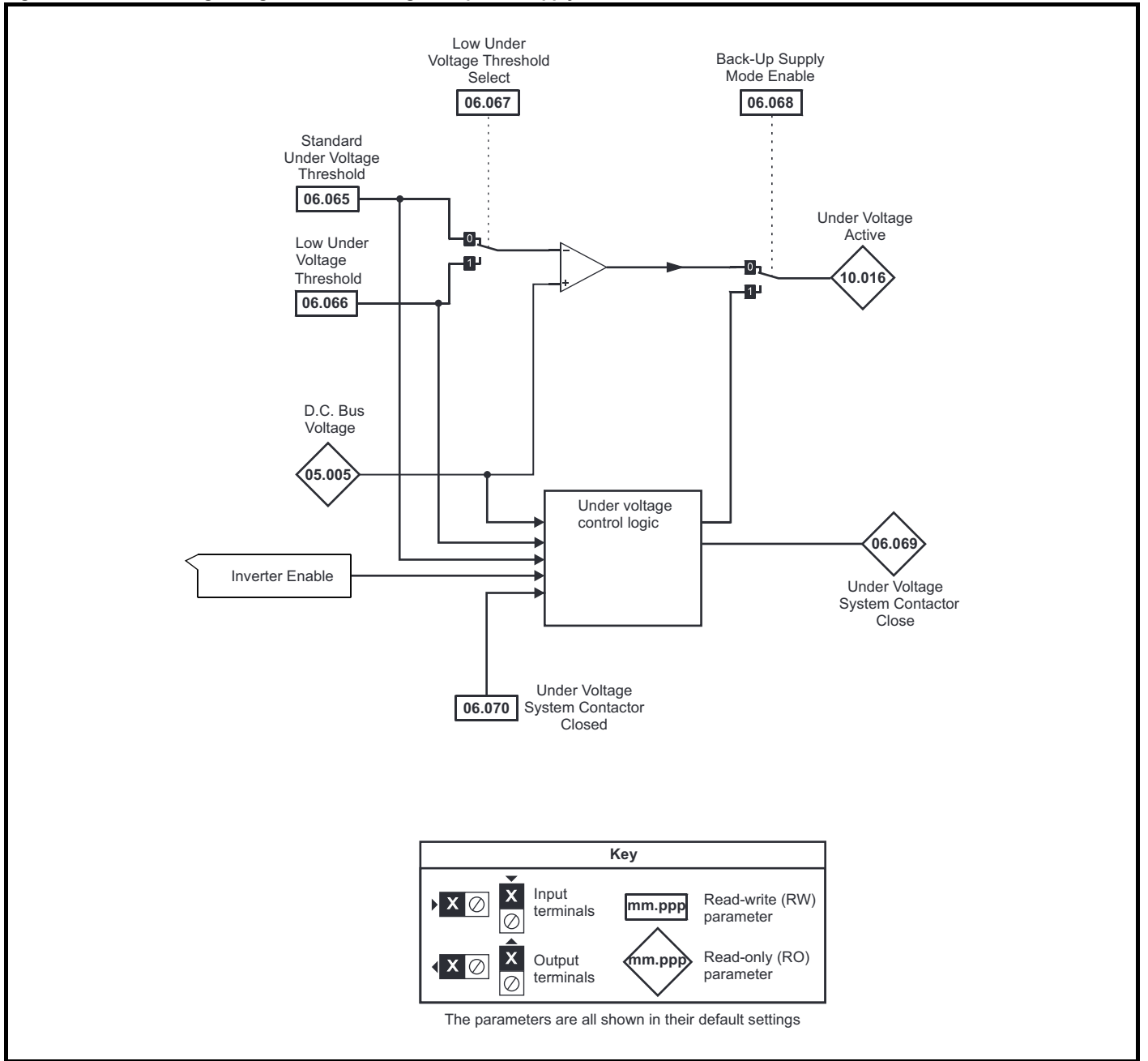
RW	Read / Write	RO	Read only	Num	Number parameter	Bit	Bit parameter	Txt	Text string	Bin	Binary parameter	FI	Filtered
ND	No default value	NC	Not copied	PT	Protected parameter	RA	Rating dependent	US	User save	PS	Power-down save	DE	Destination

## 12.7 Menu 6: Sequencer and clock

Figure 12-15 Menu 6 logic diagram



**Figure 12-16 Menu 6 logic diagram: Under voltage and power supply control**



Parameter	Range(⚡)		Default(⇄)			Type							
	OL	RFC-A / S	OL	RFC-A	RFC-S								
06.001	Stop Mode	Coast (0), Ramp (1), Ramp d c l (2), dc l (3), Timed dc l (4), Disable (5)	Coast (0), Ramp (1), No Ramp (2)	Ramp (1)	Ramp (1)	No Ramp (2)	RW	Txt					US
06.002	Limit Switch Stop Mode		Stop (0) or Ramp (1)		Stop (0)		RW	Txt					US
06.003	Supply Loss Mode	Disable (0), Ramp Stop (1), Ride Thru (2)	Disable (0), Ramp Stop (1), Ride Thru (2), Limit Stop (3)	Disable (0)			RW	Txt					US
06.006	Injection Braking Level	0.0 to 150.0 %		100.0 %			RW	Num		RA			US
06.007	Injection Braking Time	0.0 to 100.0 s		1.0 s			RW	Num					US
06.008	Hold Zero Speed	Off (0) or On (1)		Off (0)		On (1)	RW	Bit					US
06.009	Catch A Spinning Motor	Disable (0), Enable (1), Fwd Only (2), Rev Only (3)		Disable (0)	Enable (1)		RW	Txt					US
06.010	Enable Conditions	000000000000 to 111111111111					RO	Bin	ND	NC	PT		
06.011	Sequencer State Machine Inputs	000000 to 111111					RO	Bin	ND	NC	PT		
06.012	Enable Stop Key	Off (0) or On (1)		Off (0)			RW	Bit					US
06.013	Enable Auxiliary Key	Disabled (0), Forward / Reverse (1), Run Reverse (2)		Disabled (0)			RW	Txt					US
06.015	Drive Enable	Off (0) or On (1)		On (1)			RW	Bit					US
06.016	Date	00-00-00 to 31-12-99		00-00-00			RW	Date	ND	NC	PT		
06.017	Time	00:00:00 to 23:59:59					RW	Time	ND	NC	PT		
06.018	Day Of Week	Sunday (0), Monday (1), Tuesday (2), Wednesday (3), Thursday (4), Friday (5), Saturday (6)					RO	Txt	ND	NC	PT		
06.019	Date/Time Selector	Set (0), Powered (1), Running (2), Acc Powered (3), Local Keypad (4), Remote Keypad (5)		Powered (1)			RW	Txt					US
06.020	Date Format	Std (0) or US (1)		Std (0)			RW	Txt					US
06.021	Time Between Filter Changes	0 to 30000 Hours		0 Hours			RW	Num					US
06.022	Filter Change Required / Change Done	Off (0) or On (1)		Off (0)			RW	Bit	ND	NC			
06.023	Time Before Filter Change Due	0 to 30000 Hours					RO	Num	ND	NC	PT	PS	
06.024	Reset Energy Meter	Off (0) or On (1)		Off (0)			RW	Bit					
06.025	Energy Meter: MWh	-999.9 to 999.9 MWh					RO	Num	ND	NC	PT	PS	
06.026	Energy Meter: kWh	±99.99 kWh					RO	Num	ND	NC	PT	PS	
06.027	Energy Cost Per kWh	0.0 to 600.0		0.0			RW	Num					US
06.028	Running Cost	±32000					RO	Num	ND	NC	PT		
06.029	Hardware Enable	Off (0) or On (1)					RO	Bit	ND	NC	PT		
06.030	Run Forward	Off (0) or On (1)		Off (0)			RW	Bit		NC			
06.031	Jog	Off (0) or On (1)		Off (0)			RW	Bit		NC			
06.032	Run Reverse	Off (0) or On (1)		Off (0)			RW	Bit		NC			
06.033	Forward/Reverse	Off (0) or On (1)		Off (0)			RW	Bit		NC			
06.034	Run	Off (0) or On (1)		Off (0)			RW	Bit		NC			
06.035	Forward Limit Switch	Off (0) or On (1)		Off (0)			RW	Bit		NC			
06.036	Reverse Limit Switch	Off (0) or On (1)		Off (0)			RW	Bit		NC			
06.037	Jog Reverse	Off (0) or On (1)		Off (0)			RW	Bit		NC			
06.039	Not Stop	Off (0) or On (1)		Off (0)			RW	Bit		NC			
06.040	Enable Sequencer Latching	Off (0) or On (1)		Off (0)			RW	Bit					US
06.041	Drive Event Flags	00 to 11		01			RW	Bin		NC			
06.042	Control Word	00000000000000 to 11111111111111		00000000000000			RW	Bin		NC			
06.043	Control Word Enable	Off (0) or On (1)		Off (0)			RW	Bit					US
06.044	Active Supply	Off (0) or On (1)					RO	Bit	ND	NC	PT		
06.045	Cooling Fan control	0 to 11		-10			RW	Num					US
06.047	Input Phase Loss Detection Mode	Full (0), Ripple Only (1), Disabled (2)		Full (0)			RW	Txt					US
06.048	Supply Loss Detection Level	0 to VM_SUPPLY_LOSS_LEVEL V		200 V drive: 205 V 400 V drive: 410 V			RW	Num		RA			US
06.051	Hold Supply Loss Active	Off (0) or On (1)		Off (0)			RW	Bit		NC			
06.052	Motor Pre-heat Current Magnitude	0 to 100 %		0 %			RW	Num					US
06.058	Output Phase Loss Detection Time	0.5 s (0), 1.0 s (1), 2.0 s (2), 4.0 s (3)		0.5 s (0)			RW	Txt					US
06.059	Output Phase Loss Detection Enable	Disabled (0), Phases (1), Devices (2)		Disabled (0)			RW	Txt					US
06.060	Standby Mode Enable	Off (0) or On (1)		Off (0)			RW	Bit					US
06.061	Standby Mode Mask	0000000 to 1111111		0000000			RW	Bin					US
06.065	Standard Under Voltage Threshold	0 to VM_STD_UNDER_VOLTS V		200 V drive: 230 V 400 V drive: 375 V			RW	Num		RA			US
06.066	Low Under Voltage Threshold	24 to VM_LOW_UNDER_VOLTS V		200 V drive: 175 V 400 V drive: 330 V			RW	Num		RA			US
06.067	Low Under Voltage Threshold Select	Off (0) or On (1)		Off (0)			RW	Bit					US

Parameter		Range(↕)		Default(⇒)			Type						
		OL	RFC-A / S	OL	RFC-A	RFC-S							
06.068	Back Up Supply Mode Enable	Off (0) or On (1)		Off (0)			RW	Bit					US
06.069	Under-Voltage System Contactor Close	Off (0) or On (1)					RO	Bit	ND	NC	PT		
06.070	Under-Voltage System Contactor Closed	Off (0) or On (1)		Off (0)			RW	Bit					
06.073	Braking IGBT Lower Threshold	0 to VM_DC_VOLTAGE_SET V		200 V drive: 390 V 400 V drive: 780 V			RW	Num		RA			US
06.074	Braking IGBT Upper Threshold	0 to VM_DC_VOLTAGE_SET V		200 V drive: 390 V 400 V drive: 780 V			RW	Num		RA			US
06.075	Low Voltage Braking IGBT Threshold	0 to VM_DC_VOLTAGE_SET V		0V			RW	Num		RA			US
06.076	Low Voltage Braking IGBT Threshold Select	Off (0) or On (1)		Off (0)			RW	Bit					
06.084	Date And Time Offset	± 24.00 Hours		0.00 Hours			RW	Num					US

RW	Read / Write	RO	Read only	Num	Number parameter	Bit	Bit parameter	Txt	Text string	Bin	Binary parameter	FI	Filtered
ND	No default value	NC	Not copied	PT	Protected parameter	RA	Rating dependent	US	User save	PS	Power-down save	DE	Destination

## 12.8 Menu 7: Analog I/O / Temperature Monitoring

Figure 12-17 Menu 7 logic diagram

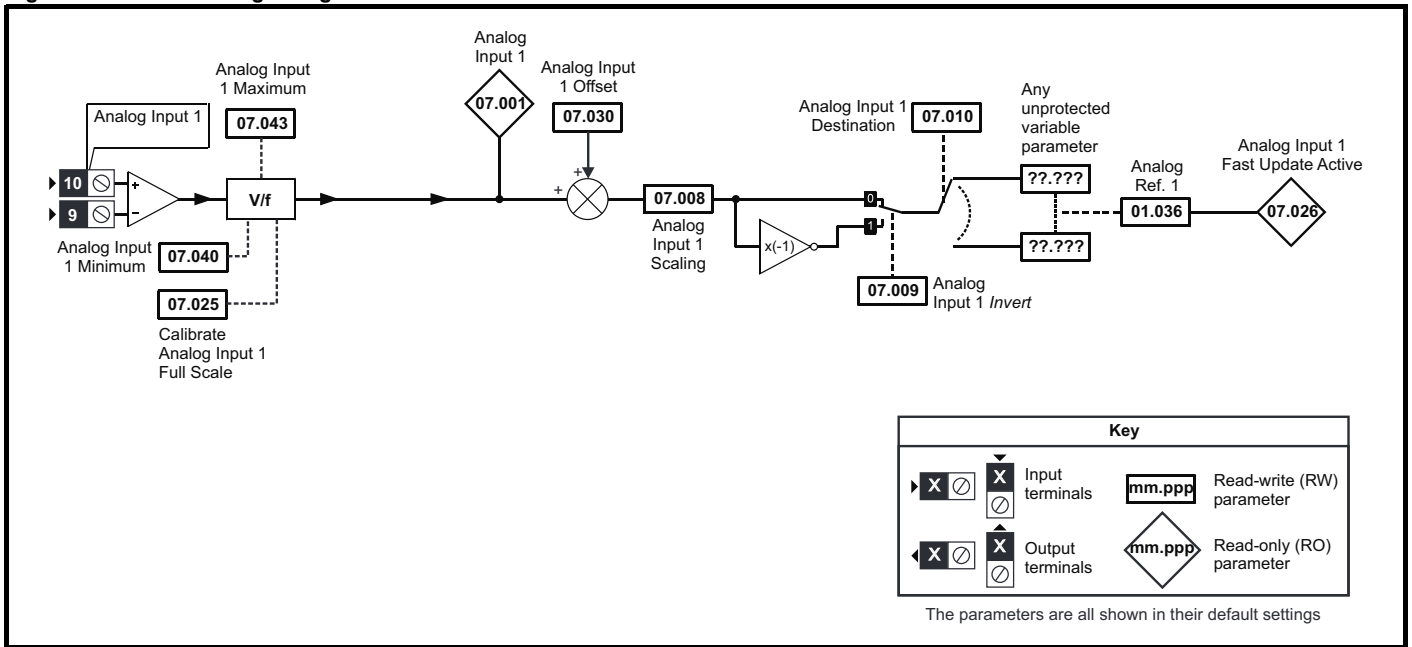
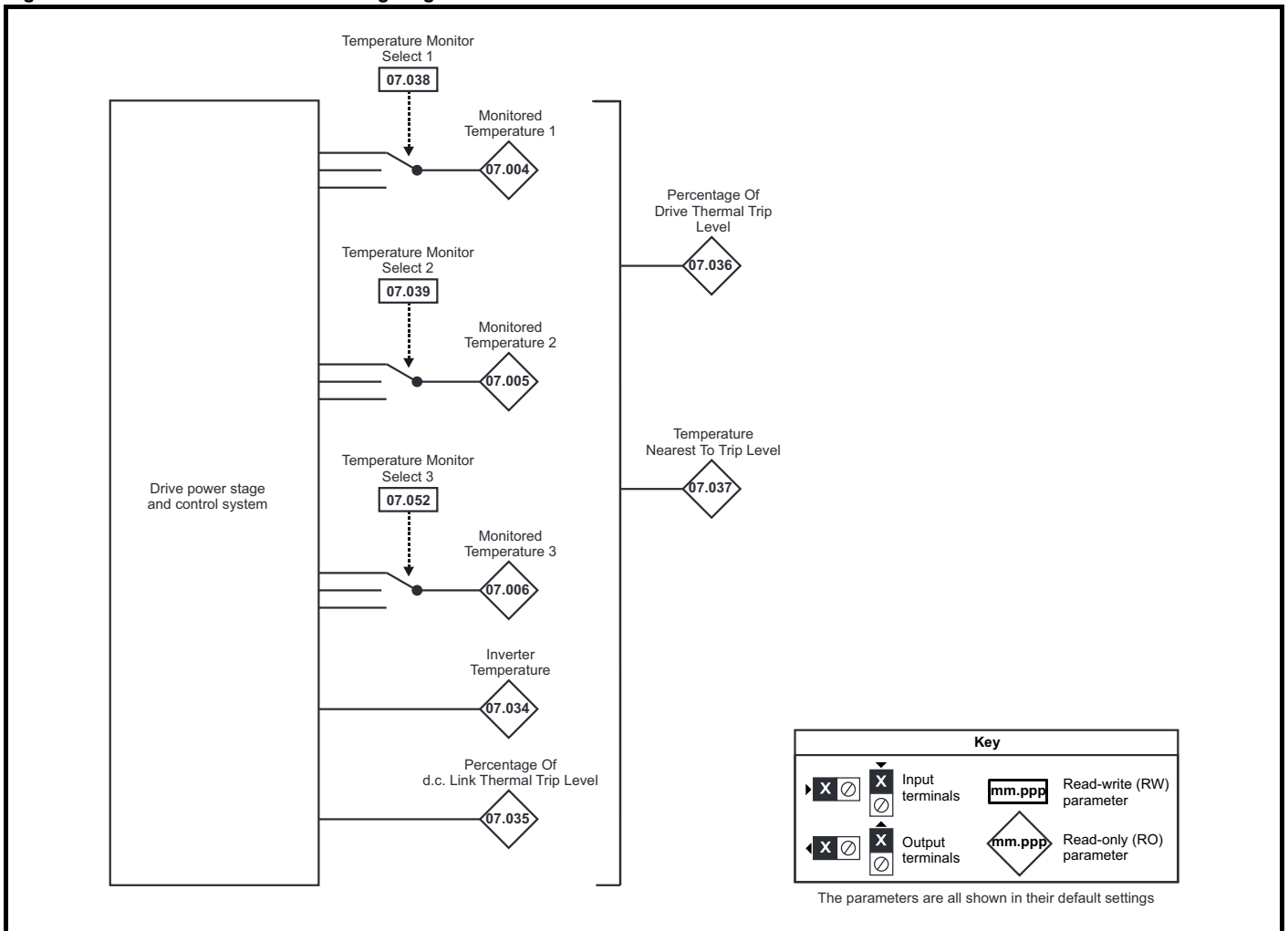


Figure 12-18 Menu 7 thermal monitoring diagram



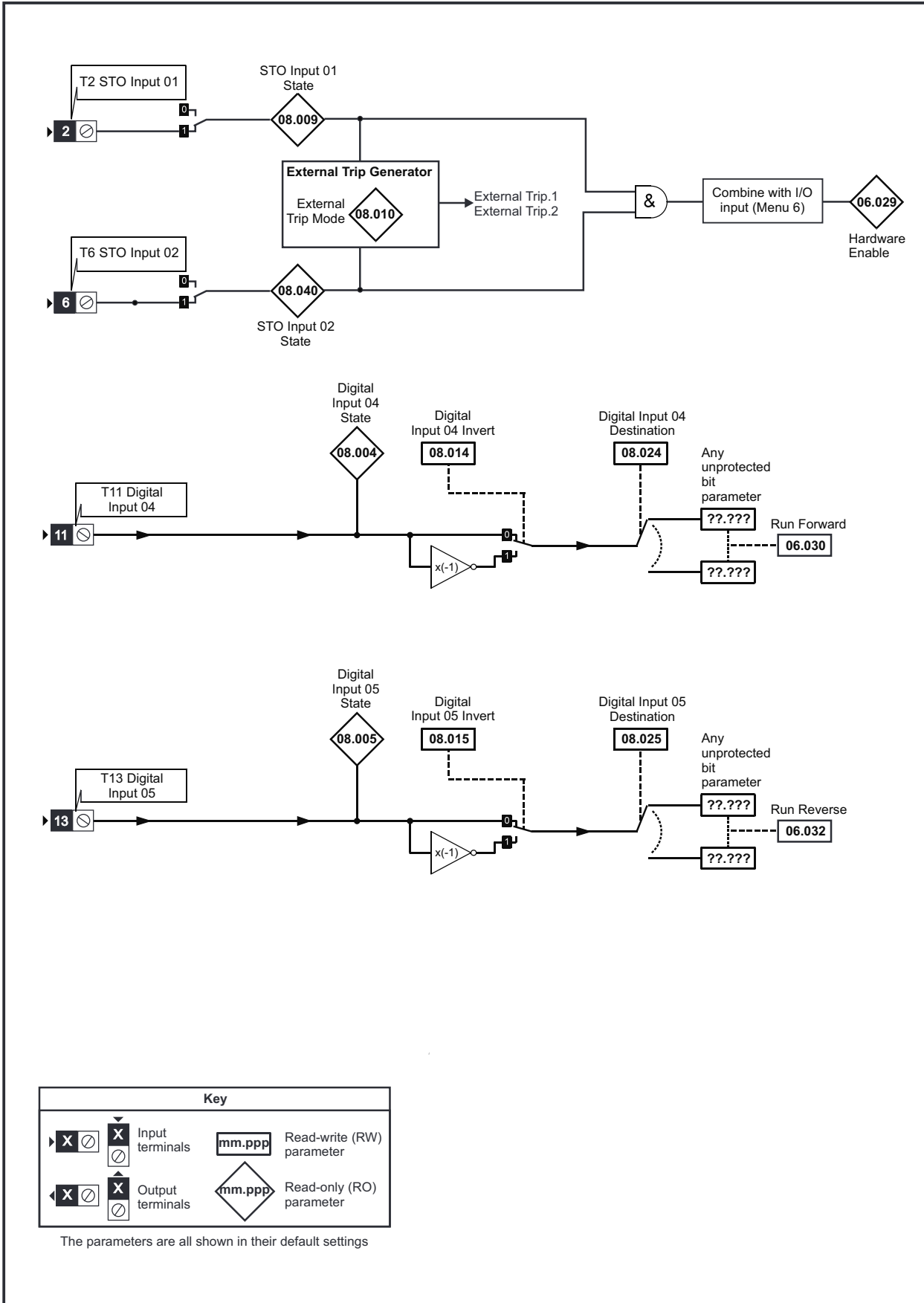
Parameter	Range(φ)		Default(⇔)			Type						
	OL	RFC-A / S	OL	RFC-A	RFC-S							
07.001	Analog Input 1	±100.00 %				RO	Num	ND	NC	PT	FI	
07.004	Monitored Temperature 1	±250 °C				RO	Num	ND	NC	PT		
07.005	Monitored Temperature 2	±250 °C				RO	Num	ND	NC	PT		
07.006	Monitored Temperature 3	±250 °C				RO	Num	ND	NC	PT		
07.008	Analog Input 1 Scaling	0.000 to 10.000			1.000	RW	Num					US
07.009	Analog Input 1 Invert	Off (0) or On (1)			Off (0)	RW	Bit					US
07.010	Analog Input 1 Destination	0.000 to 59.999			1.036	RW	Num	DE		PT		US
07.025	Calibrate Analog Input 1 Full Scale	Off (0) or On (1)			Off (0)	RW	Bit		NC			
07.026	Analog Input 1 Fast Update Active	Off (0) or On (1)				RO	Bit	ND	NC	PT		
07.030	Analog Input 1 Offset	±100.00 %			0.00 %	RW	Num					US
07.033	Power Output	±100.0 %				RO	Num	ND	NC	PT		
07.034	Inverter Temperature	±250 °C				RO	Num	ND	NC	PT		
07.035	Percentage Of d.c. Bus Thermal Trip Level	0 to 100 %				RO	Num	ND	NC	PT		
07.036	Percentage Of Drive Thermal Trip Level	0 to 100 %				RO	Num	ND	NC	PT		
07.037	Temperature Nearest To Trip Level	0 to 20999				RO	Num	ND	NC	PT		
07.038	Temperature Monitor Select 1	0 to 1999			1001	RW	Num					US
07.039	Temperature Monitor Select 2	0 to 1999			1002	RW	Num					US
07.040	Analog Input 1 Minimum	±100.00 %			-100.00 %	RW	Num					US
07.043	Analog Input 1 Maximum	±100.00 %			100.00 %	RW	Num					US
07.051	Analog Input 1 Full Scale	0 to 65535				RO	Num	ND	NC	PT	PS	
07.052	Temperature Monitor Select 3	0 to 1999			1	RW	Num					US

RW	Read / Write	RO	Read only	Num	Number parameter	Bit	Bit parameter	Txt	Text string	Bin	Binary parameter	FI	Filtered
ND	No default value	NC	Not copied	PT	Protected parameter	RA	Rating dependent	US	User save	PS	Power-down save	DE	Destination

Safety information	Product information	Mechanical installation	Electrical installation	Getting started	Basic parameters	Running the motor	Optimization	Drive communication	SD Card Operation	Onboard PLC	<b>Advanced parameters</b>	Diagnostics	UL listing information
--------------------	---------------------	-------------------------	-------------------------	-----------------	------------------	-------------------	--------------	---------------------	-------------------	-------------	----------------------------	-------------	------------------------

## 12.9 Menu 8: Digital I/O

Figure 12-19 Menu 8 Digital input and outputs logic diagram



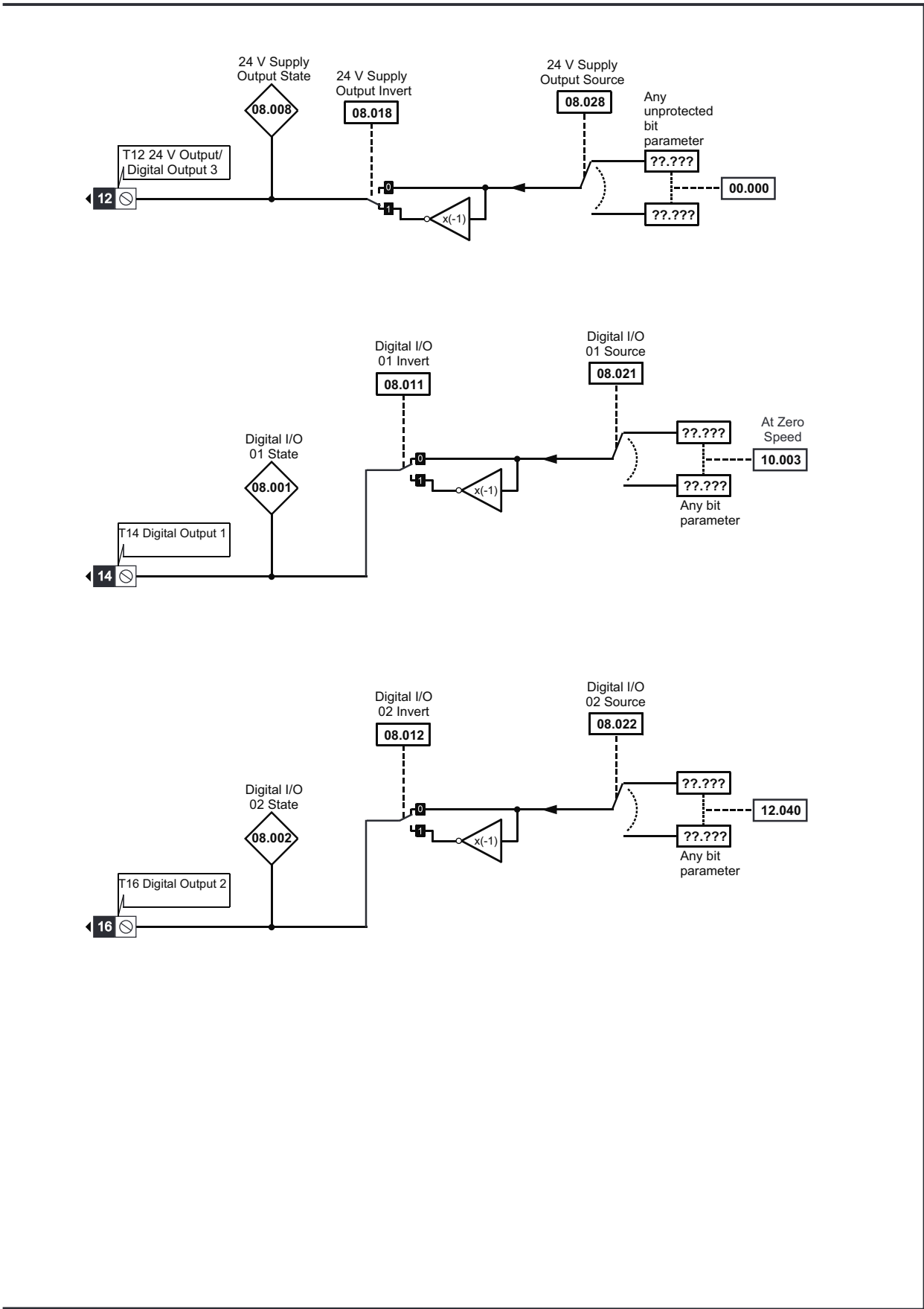
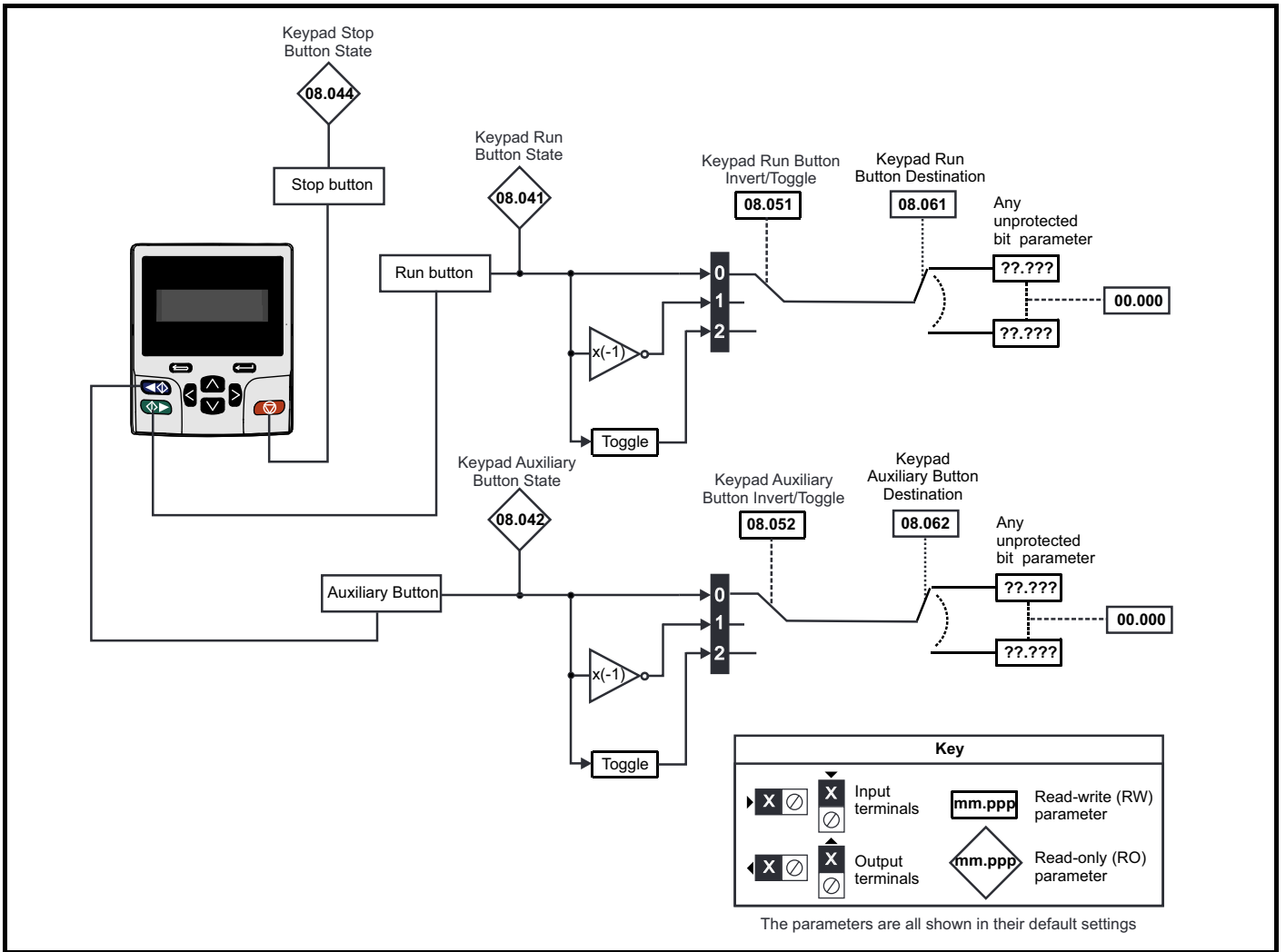


Figure 12-20 Menu 8 Remote Keypad RTC buttons logic diagram

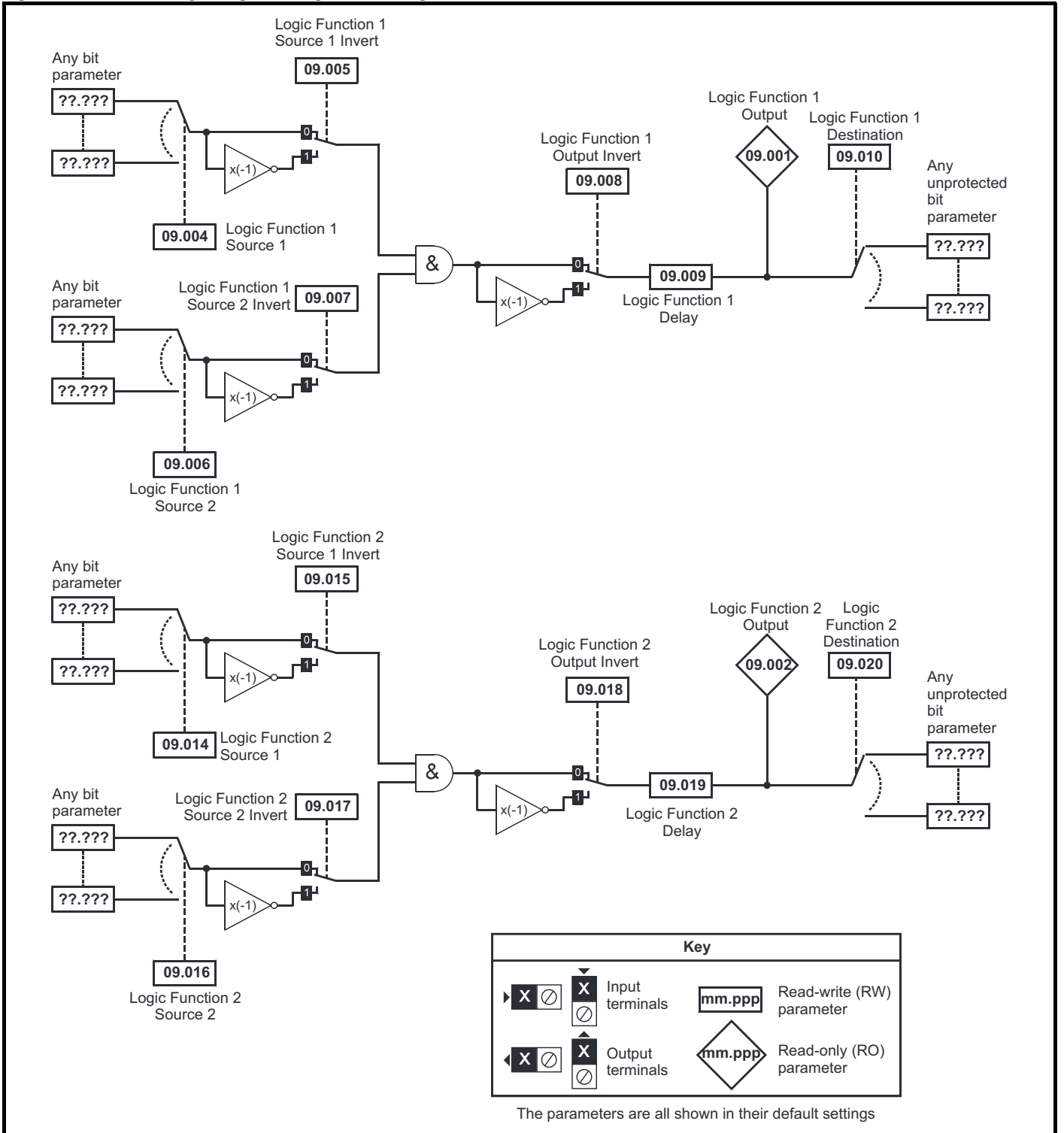


Parameter	Range(⌀)		Default(⇄)			Type					
	OL	RFC-A / S	OL	RFC-A	RFC-S						
08.001	Digital I/O 01 State	Off (0) or On (1)				RO	Bit	ND	NC	PT	
08.002	Digital I/O 02 State	Off (0) or On (1)				RO	Bit	ND	NC	PT	
08.004	Digital Input 04 State	Off (0) or On (1)				RO	Bit	ND	NC	PT	
08.005	Digital Input 05 State	Off (0) or On (1)				RO	Bit	ND	NC	PT	
08.008	24V Supply Output State	Off (0) or On (1)				RO	Bit	ND	NC	PT	
08.009	STO Input 01 State	Off (0) or On (1)				RO	Bit	ND	NC	PT	
08.010	External Trip Mode	Disable (0), STO 1 (1), STO 2 (2), STO 1 OR STO 2 (3)		Disable (0)		RW	Txt				US
08.011	Digital I/O 01 Invert	Not Invert (0) or Invert (1)		Not Invert (0)		RW	Txt				US
08.012	Digital I/O 02 Invert	Not Invert (0) or Invert (1)		Not Invert (0)		RW	Txt				US
08.014	Digital Input 04 Invert	Not Invert (0) or Invert (1)		Not Invert (0)		RW	Txt				US
08.015	Digital Input 05 Invert	Not Invert (0) or Invert (1)		Not Invert (0)		RW	Txt				US
08.018	24V Supply Output Invert	Not Invert (0) or Invert (1)		Invert (1)		RW	Txt				US
08.020	Digital I/O Read Word	0 to 511				RO	Num	ND	NC	PT	
08.021	Digital I/O 01 Source/Destination	0.000 to 59.999		10.003		RW	Num	DE		PT	US
08.022	Digital I/O 02 Source/Destination	0.000 to 59.999		12.040		RW	Num	DE		PT	US
08.024	Digital Input 04 Destination	0.000 to 59.999		6.030		RW	Num	DE		PT	US
08.025	Digital Input 05 Destination	0.000 to 59.999		6.032		RW	Num	DE		PT	US
08.028	24V Supply Output Source	0.000 to 59.999		0.000		RW	Num			PT	US
08.040	STO Input 02 State	Off (0) or On (1)				RO	Bit	ND	NC	PT	
08.041	Keypad Run Button State	Off (0) or On (1)				RO	Bit	ND	NC	PT	
08.042	Keypad Auxiliary Button State	Off (0) or On (1)				RO	Bit	ND	NC	PT	
08.044	Keypad Stop Button State	Off (0) or On (1)				RO	Bit	ND	NC	PT	
08.046	Drive Reset Button State	Off (0) or On (1)				RO	Bit	ND	NC	PT	
08.051	Keypad Run Button Invert/Toggle	Not Invert (0), Invert (1) or Toggle (2)		Not Invert (0)		RW	Txt				US
08.052	Keypad Auxiliary Button Invert/Toggle	Not Invert (0), Invert (1) or Toggle (2)		Not Invert (0)		RW	Txt				US
08.061	Keypad Run Button Destination	0.000 to 59.999		0.000		RW	Num	DE		PT	US
08.062	Keypad Auxiliary Button Destination	0.000 to 59.999		0.000		RW	Num	DE		PT	US
08.071	DI/O Output Enable Register 1	0000000000000000 to 1111111111111111		0000000000000000		RW	Bin			PT	US
08.072	DI/O Input Register 1	0000000000000000 to 1111111111111111				RO	Bin	ND	NC	PT	
08.073	DI/O Output Register 1	0000000000000000 to 1111111111111111		0000000000000000		RW	Bin			PT	

RW	Read / Write	RO	Read only	Num	Number parameter	Bit	Bit parameter	Txt	Text string	Bin	Binary parameter	FI	Filtered
ND	No default value	NC	Not copied	PT	Protected parameter	RA	Rating dependent	US	User save	PS	Power-down save	DE	Destination

## 12.10 Menu 9: Programmable logic, motorized pot, binary sum and timers

Figure 12-21 Menu 9 logic diagram: Programmable logic



**Figure 12-22 Menu 9 logic diagram: Motorized pot and binary sum**

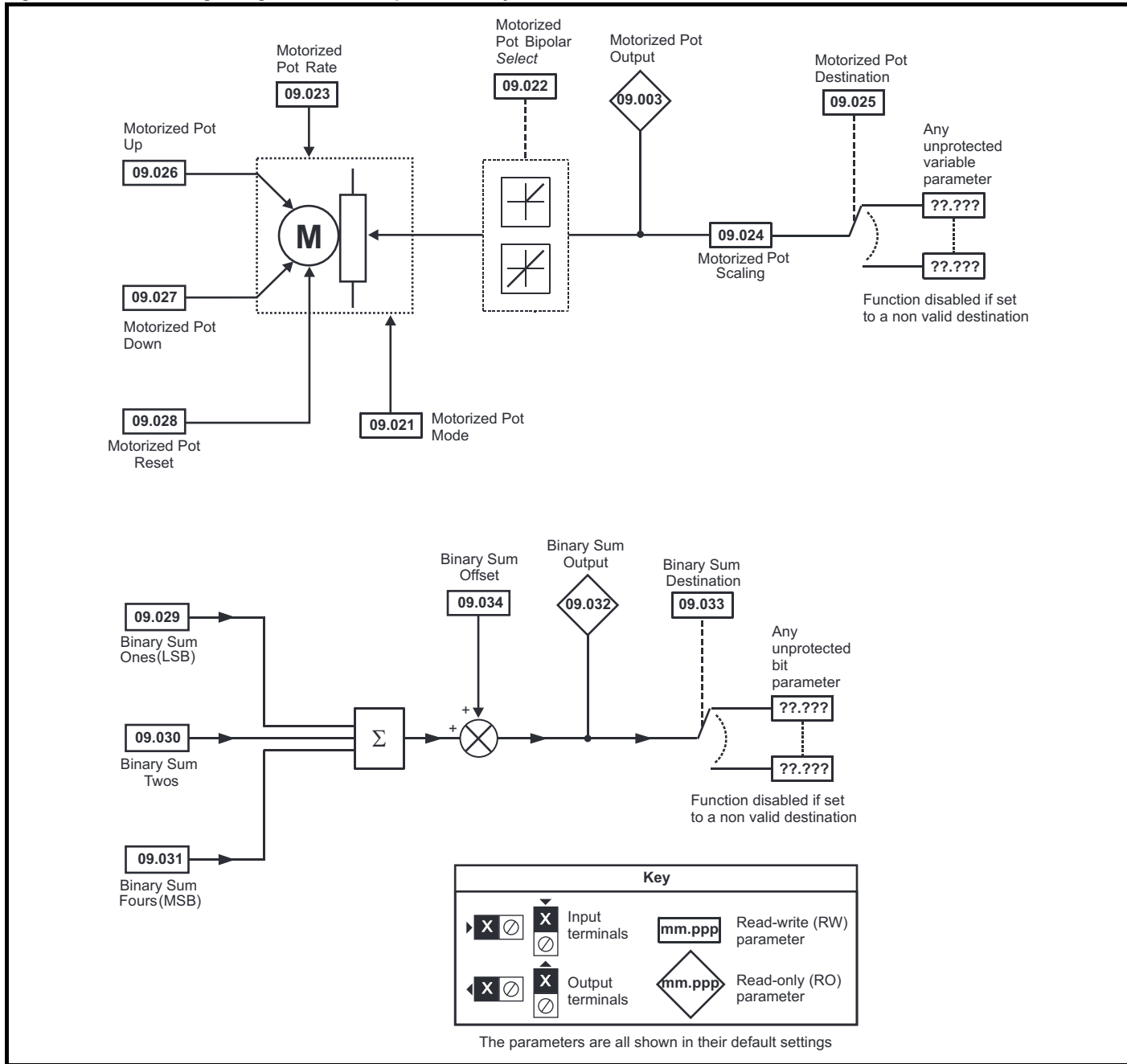
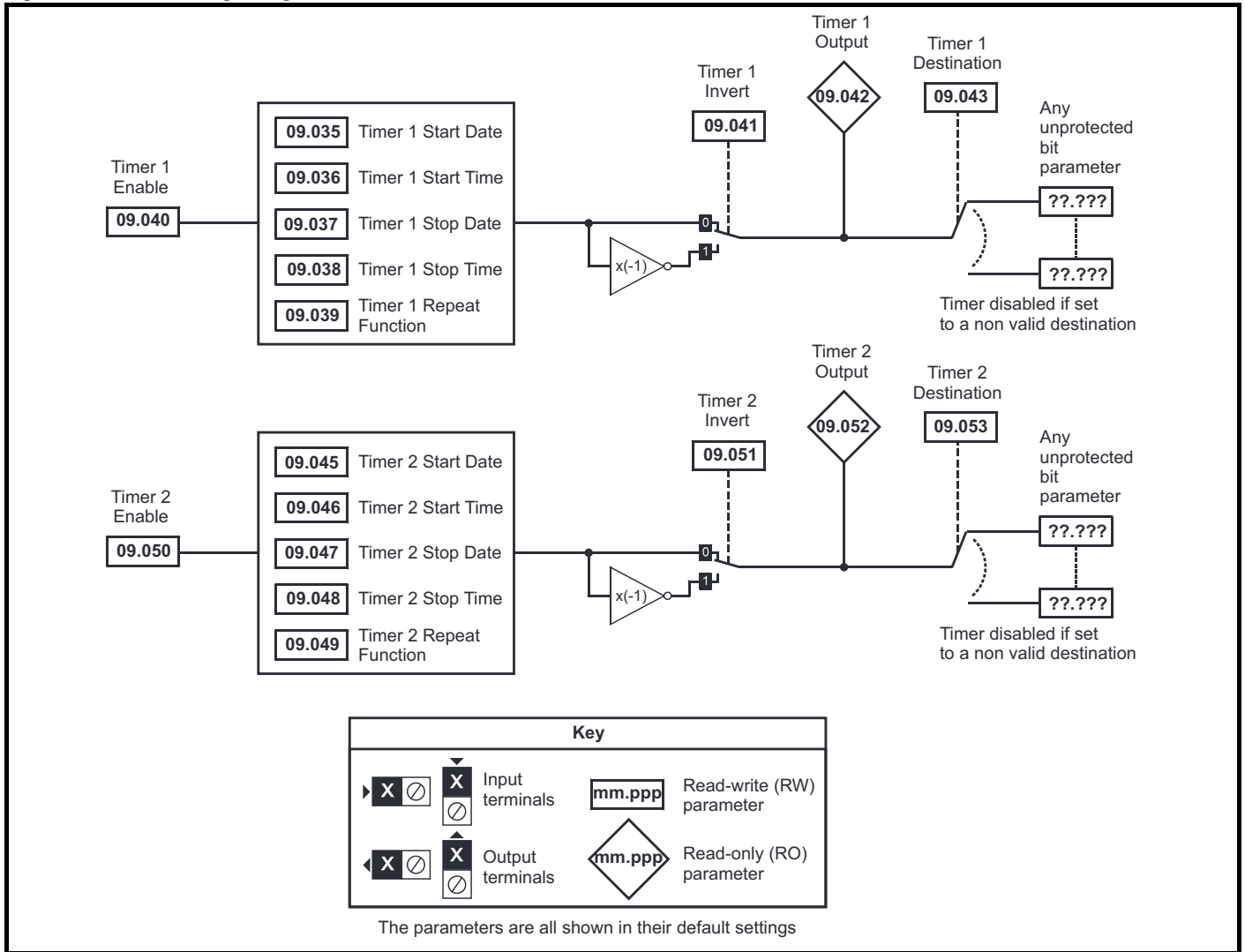
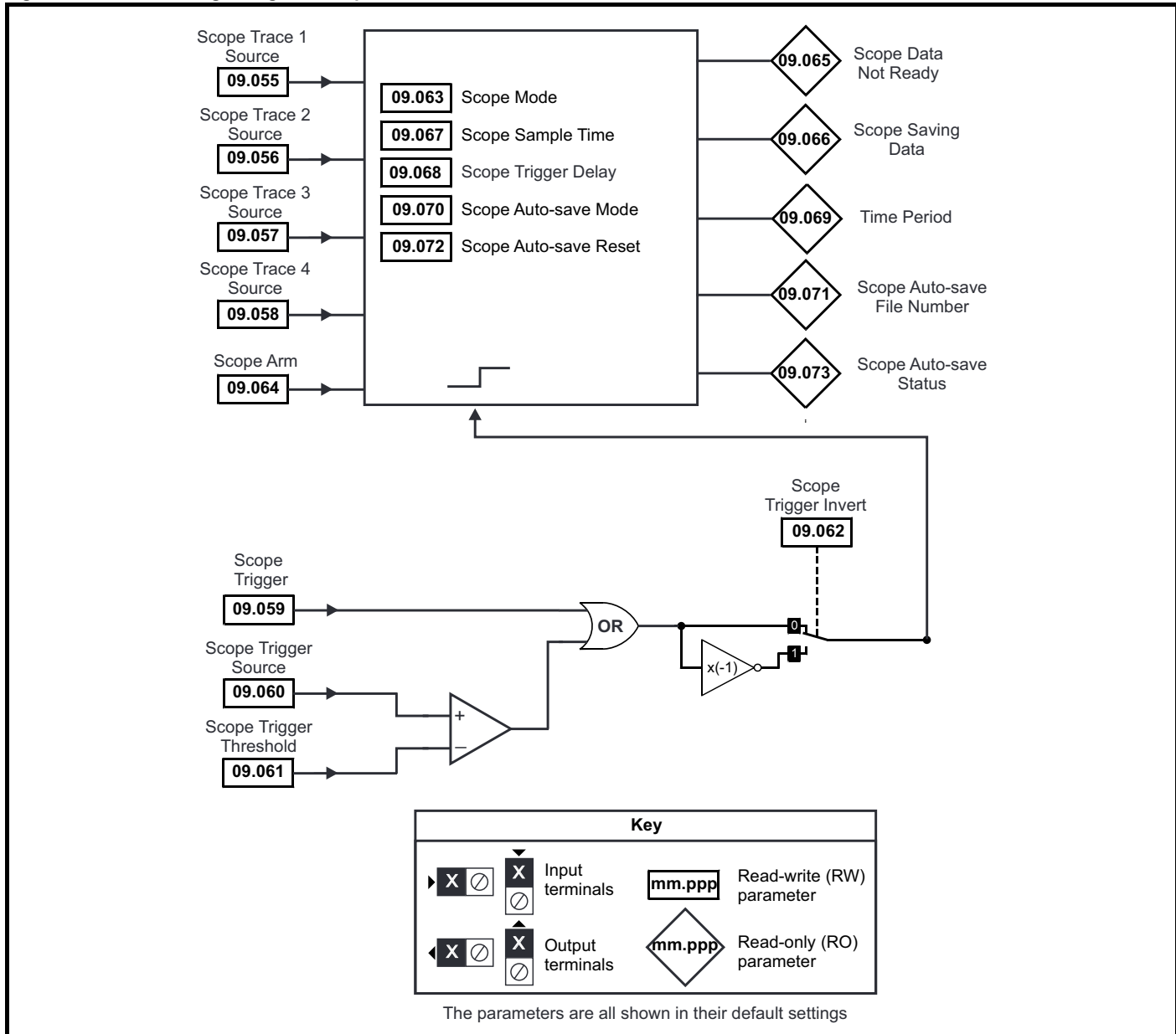


Figure 12-23 Menu 9 logic diagram: Timers



**Figure 12-24 Menu 9 logic diagram: Scope function**



Parameter	Range(φ)		Default(⇒)			Type						
	OL	RFC-A / S	OL	RFC-A	RFC-S	RO	Bit	ND	NC	PT		
09.001	Logic Function 1 Output		Off (0) or On (1)				RO	Bit	ND	NC	PT	
09.002	Logic Function 2 Output		Off (0) or On (1)				RO	Bit	ND	NC	PT	
09.003	Motorized Pot Output		±100.00 %				RO	Num	ND	NC	PT	PS
09.004	Logic Function 1 Source 1		0.000 to 59.999			0.000	RW	Num			PT	US
09.005	Logic Function 1 Source 1 Invert		Off (0) or On (1)			Off (0)	RW	Bit				US
09.006	Logic Function 1 Source 2		0.000 to 59.999			0.000	RW	Num			PT	US
09.007	Logic Function 1 Source 2 Invert		Off (0) or On (1)			Off (0)	RW	Bit				US
09.008	Logic Function 1 Output Invert		Off (0) or On (1)			Off (0)	RW	Bit				US
09.009	Logic Function 1 Delay		±25.0 s			0.0 s	RW	Num				US
09.010	Logic Function 1 Destination		0.000 to 59.999			0.000	RW	Num	DE		PT	US
09.014	Logic Function 2 Source 1		0.000 to 59.999			0.000	RW	Num			PT	US
09.015	Logic Function 2 Source 1 Invert		Off (0) or On (1)			Off (0)	RW	Bit				US
09.016	Logic Function 2 Source 2		0.000 to 59.999			0.000	RW	Num			PT	US
09.017	Logic Function 2 Source 2 Invert		Off (0) or On (1)			Off (0)	RW	Bit				US
09.018	Logic Function 2 Output Invert		Off (0) or On (1)			Off (0)	RW	Bit				US
09.019	Logic Function 2 Delay		±25.0 s			0.0 s	RW	Num				US
09.020	Logic Function 2 Destination		0.000 to 59.999			0.000	RW	Num	DE		PT	US
09.021	Motorized Pot Mode		0 to 4			0	RW	Num				US
09.022	Motorized Pot Bipolar Select		Off (0) or On (1)			Off (0)	RW	Bit				US
09.023	Motorized Pot Rate		0 to 250 s			20 s	RW	Num				US
09.024	Motorized Pot Scaling		0.000 to 4.000			1.000	RW	Num				US
09.025	Motorized Pot Destination		0.000 to 59.999			0.000	RW	Num	DE		PT	US
09.026	Motorized Pot Up		Off (0) or On (1)			Off (0)	RW	Bit		NC		
09.027	Motorized Pot Down		Off (0) or On (1)			Off (0)	RW	Bit		NC		
09.028	Motorized Pot Reset		Off (0) or On (1)			Off (0)	RW	Bit		NC		
09.029	Binary Sum Ones		Off (0) or On (1)			Off (0)	RW	Bit		NC		
09.030	Binary Sum Twos		Off (0) or On (1)			Off (0)	RW	Bit		NC		
09.031	Binary Sum Fours		Off (0) or On (1)			Off (0)	RW	Bit		NC		
09.032	Binary Sum Output		0 to 255				RO	Num	ND	NC	PT	
09.033	Binary Sum Destination		0.000 to 59.999			0.000	RW	Num	DE		PT	US
09.034	Binary Sum Offset		0 to 248			0	RW	Num				US
09.035	Timer 1 Start Date		00-00-00 to 31-12-99			00-00-00	RW	Date				US
09.036	Timer 1 Start Time		00:00:00 to 23:59:59			00:00:00	RW	Time				US
09.037	Timer 1 Stop Date		00-00-00 to 31-12-99			00-00-00	RW	Date				US
09.038	Timer 1 Stop Time		00:00:00 to 23:59:59			00:00:00	RW	Time				US
09.039	Timer 1 Repeat Function		None (0), Hour (1), Day (2), Week (3), Month (4), Year (5), One off (6), Minute (7)			None (0)	RW	Txt				US
09.040	Timer 1 Enable		Off (0) or On (1)			Off (0)	RW	Bit				US
09.041	Timer 1 Invert		Off (0) or On (1)			Off (0)	RW	Bit				US
09.042	Timer 1 Output		Off (0) or On (1)				RO	Bit	ND	NC	PT	
09.043	Timer 1 Destination		0.000 to 59.999			0.000	RW	Num	DE		PT	US
09.045	Timer 2 Start Date		00-00-00 to 31-12-99			00-00-00	RW	Date				US
09.046	Timer 2 Start Time		00:00:00 to 23:59:59			00:00:00	RW	Time				US
09.047	Timer 2 Stop Date		00-00-00 to 31-12-99			00-00-00	RW	Date				US
09.048	Timer 2 Stop Time		00:00:00 to 23:59:59			00:00:00	RW	Time				US
09.049	Timer 2 Repeat Function		None (0), Hour (1), Day (2), Week (3), Month (4), Year (5), One off (6), Minute (7)			None (0)	RW	Txt				US
09.050	Timer 2 Enable		Off (0) or On (1)			Off (0)	RW	Bit				US
09.051	Timer 2 Invert		Off (0) or On (1)			Off (0)	RW	Bit				US
09.052	Timer 2 Output		Off (0) or On (1)				RO	Bit	ND	NC	PT	
09.053	Timer 2 Destination		0.000 to 59.999			0.000	RW	Num	DE		PT	US
09.055	Scope Trace 1 Source		0.000 to 59.999			5.001	3.002	RW	Num		PT	US
09.056	Scope Trace 2 Source		0.000 to 59.999			4.002		RW	Num		PT	US
09.057	Scope Trace 3 Source		0.000 to 59.999			0.000		RW	Num		PT	US
09.058	Scope Trace 4 Source		0.000 to 59.999			0.000		RW	Num		PT	US
09.059	Scope Trigger		Off (0) or On (1)			Off (0)		RW	Bit			
09.060	Scope Trigger Source		0.000 to 59.999			10.001		RW	Num		PT	US
09.061	Scope Trigger Threshold		-2147483648 to 2147483647			0		RW	Num			US
09.062	Scope Trigger Invert		Off (0) or On (1)			Off (0)		RW	Bit			US
09.063	Scope Mode		Single (0), Normal (1), Auto (2)			Normal (1)		RW	Txt			US

Parameter		Range(↕)		Default(⇒)			Type						
		OL	RFC-A / S	OL	RFC-A	RFC-S	RW	Bit	NC	PT			
09.064	Scope Arm	Off (0) or On (1)		Off (0)			RW	Bit		NC			
09.065	Scope Data Not Ready	Off (0) or On (1)					RO	Bit	ND	NC	PT		
09.066	Scope Saving Data	Off (0) or On (1)					RO	Bit	ND	NC	PT		
09.067	Scope Sample Time	1 to 200		4			RW	Num					US
09.068	Scope Trigger Delay	0 to 100 %		100 %			RW	Num					US
09.069	Scope Time Period	0.00 to 200000.00 ms					RO	Num	ND	NC	PT		
09.070	Scope Auto-save Mode	Disabled (0), Overwrite (1), Keep (2)		Disabled (0)			RW	Txt					US
09.071	Scope Auto-save File Number	0 to 99					RO	Num					PS
09.072	Scope Auto-save Reset	Off (0) or On (1)		Off (0)			RW	Bit					
09.073	Scope Auto-save Status	Disabled (0), Active (1), Stopped (2), Failed (3)					RO	Txt					PS

RW	Read / Write	RO	Read only	Num	Number parameter	Bit	Bit parameter	Txt	Text string	Bin	Binary parameter	FI	Filtered
ND	No default value	NC	Not copied	PT	Protected parameter	RA	Rating dependent	US	User save	PS	Power-down save	DE	Destination
IP	IP address	Mac	Mac address	Date	Date parameter	Time	Time parameter	SMP	Slot,menu,parameter	Chr	Character parameter	Ver	Version number

## 12.11 Menu 10: Status and trips

Parameter	Range(⊕)		Default(⇨)			Type					
	OL	RFC-A / S	OL	RFC-A	RFC-S						
10.001	Drive OK	Off (0) or On (1)				RO	Bit	ND	NC	PT	
10.002	Drive Active	Off (0) or On (1)				RO	Bit	ND	NC	PT	
10.003	Zero Speed	Off (0) or On (1)				RO	Bit	ND	NC	PT	
10.004	Running At Or Below Minimum Speed	Off (0) or On (1)				RO	Bit	ND	NC	PT	
10.005	Below Set Speed	Off (0) or On (1)				RO	Bit	ND	NC	PT	
10.006	At Speed	Off (0) or On (1)				RO	Bit	ND	NC	PT	
10.007	Above Set Speed	Off (0) or On (1)				RO	Bit	ND	NC	PT	
10.008	Rated Load Reached	Off (0) or On (1)				RO	Bit	ND	NC	PT	
10.009	Current Limit Active	Off (0) or On (1)				RO	Bit	ND	NC	PT	
10.010	Regenerating	Off (0) or On (1)				RO	Bit	ND	NC	PT	
10.011	Braking IGBT Active	Off (0) or On (1)				RO	Bit	ND	NC	PT	
10.012	Braking Resistor Alarm	Off (0) or On (1)				RO	Bit	ND	NC	PT	
10.013	Reverse Direction Commanded	Off (0) or On (1)				RO	Bit	ND	NC	PT	
10.014	Reverse Direction Running	Off (0) or On (1)				RO	Bit	ND	NC	PT	
10.015	Supply Loss	Off (0) or On (1)				RO	Bit	ND	NC	PT	
10.016	Under Voltage Active	Off (0) or On (1)				RO	Bit	ND	NC	PT	
10.017	Motor Overload Alarm	Off (0) or On (1)				RO	Bit	ND	NC	PT	
10.018	Drive Over-temperature Alarm	Off (0) or On (1)				RO	Bit	ND	NC	PT	
10.019	Drive Warning	Off (0) or On (1)				RO	Bit	ND	NC	PT	
10.020	Trip 0	0 to 255				RO	Txt	ND	NC	PT	PS
10.021	Trip 1	0 to 255				RO	Txt	ND	NC	PT	PS
10.022	Trip 2	0 to 255				RO	Txt	ND	NC	PT	PS
10.023	Trip 3	0 to 255				RO	Txt	ND	NC	PT	PS
10.024	Trip 4	0 to 255				RO	Txt	ND	NC	PT	PS
10.025	Trip 5	0 to 255				RO	Txt	ND	NC	PT	PS
10.026	Trip 6	0 to 255				RO	Txt	ND	NC	PT	PS
10.027	Trip 7	0 to 255				RO	Txt	ND	NC	PT	PS
10.028	Trip 8	0 to 255				RO	Txt	ND	NC	PT	PS
10.029	Trip 9	0 to 255				RO	Txt	ND	NC	PT	PS
10.030	Braking Resistor Rated Power	0.000 to 99999.999 kW			0.050 kW	RW	Num				US
10.031	Braking Resistor Thermal Time Constant	0.000 to 1500.000 s			2.000 s	RW	Num				US
10.032	External Trip	Off (0) or On (1)			Off (0)	RW	Bit		NC		
10.033	Drive Reset	Off (0) or On (1)			Off (0)	RW	Bit		NC		
10.034	Number Of Auto-reset Attempts	None (0), 1 (1), 2 (2), 3 (3), 4 (4), 5 (5), Infinite (6)			None (0)	RW	Txt				US
10.035	Auto-reset Delay	1.0 to 600.0 s			1.0 s	RW	Num				US
10.036	Auto-reset Hold Drive ok	Off (0) or On (1)			Off (0)	RW	Bit				US
10.037	Action On Trip Detection	00000 to 11111			00000	RW	Bin				US
10.038	User Trip	0 to 255			0	RW	Num	ND	NC		
10.039	Braking Resistor Thermal Accumulator	0.0 to 100.0 %				RO	Num	ND	NC	PT	
10.040	Status Word	00000000000000 to 11111111111111				RO	Bin	ND	NC	PT	
10.041	Trip 0 Date	00-00-00 to 31-12-99				RO	Date	ND	NC	PT	PS
10.042	Trip 0 Time	00:00:00 to 23:59:59				RO	Time	ND	NC	PT	PS
10.043	Trip 1 Date	00-00-00 to 31-12-99				RO	Date	ND	NC	PT	PS
10.044	Trip 1 Time	00:00:00 to 23:59:59				RO	Time	ND	NC	PT	PS
10.045	Trip 2 Date	00-00-00 to 31-12-99				RO	Date	ND	NC	PT	PS
10.046	Trip 2 Time	00:00:00 to 23:59:59				RO	Time	ND	NC	PT	PS
10.047	Trip 3 Date	00-00-00 to 31-12-99				RO	Date	ND	NC	PT	PS
10.048	Trip 3 Time	00:00:00 to 23:59:59				RO	Time	ND	NC	PT	PS
10.049	Trip 4 Date	00-00-00 to 31-12-99				RO	Date	ND	NC	PT	PS
10.050	Trip 4 Time	00:00:00 to 23:59:59				RO	Time	ND	NC	PT	PS
10.051	Trip 5 Date	00-00-00 to 31-12-99				RO	Date	ND	NC	PT	PS
10.052	Trip 5 Time	00:00:00 to 23:59:59				RO	Time	ND	NC	PT	PS
10.053	Trip 6 Date	00-00-00 to 31-12-99				RO	Date	ND	NC	PT	PS
10.054	Trip 6 Time	00:00:00 to 23:59:59				RO	Time	ND	NC	PT	PS
10.055	Trip 7 Date	00-00-00 to 31-12-99				RO	Date	ND	NC	PT	PS
10.056	Trip 7 Time	00:00:00 to 23:59:59				RO	Time	ND	NC	PT	PS
10.057	Trip 8 Date	00-00-00 to 31-12-99				RO	Date	ND	NC	PT	PS

Parameter	Range(↕)		Default(⇒)			Type						
	OL	RFC-A / S	OL	RFC-A	RFC-S							
10.058	Trip 8 Time	00:00:00 to 23:59:59				RO	Time	ND	NC	PT	PS	
10.059	Trip 9 Date	00-00-00 to 31-12-99				RO	Date	ND	NC	PT	PS	
10.060	Trip 9 Time	00:00:00 to 23:59:59				RO	Time	ND	NC	PT	PS	
10.061	Braking Resistor Resistance	0.00 to 10000.00 Ω				RW	Num					US
10.063	Local Keypad Battery Low	Off (0) or On (1)				RO	Bit	ND	NC	PT		
10.064	Remote Keypad Battery Low	Off (0) or On (1)				RO	Bit	ND	NC	PT		
10.065	Auto-tune Active	Off (0) or On (1)				RO	Bit	ND	NC	PT		
10.066	Limit Switch Active	Off (0) or On (1)				RO	Bit	ND	NC	PT		
10.068	Hold Drive Healthy On Under Voltage	Off (0) or On (1)				RW	Bit					US
10.069	Additional Status Bits	0000000000 to 1111111111				RO	Bin	ND	NC	PT		
10.070	Trip 0 Sub-trip Number	0 to 65535				RO	Num	ND	NC	PT	PS	
10.071	Trip 1 Sub-trip Number	0 to 65535				RO	Num	ND	NC	PT	PS	
10.072	Trip 2 Sub-trip Number	0 to 65535				RO	Num	ND	NC	PT	PS	
10.073	Trip 3 Sub-trip Number	0 to 65535				RO	Num	ND	NC	PT	PS	
10.074	Trip 4 Sub-trip Number	0 to 65535				RO	Num	ND	NC	PT	PS	
10.075	Trip 5 Sub-trip Number	0 to 65535				RO	Num	ND	NC	PT	PS	
10.076	Trip 6 Sub-trip Number	0 to 65535				RO	Num	ND	NC	PT	PS	
10.077	Trip 7 Sub-trip Number	0 to 65535				RO	Num	ND	NC	PT	PS	
10.078	Trip 8 Sub-trip Number	0 to 65535				RO	Num	ND	NC	PT	PS	
10.079	Trip 9 Sub-trip Number	0 to 65535				RO	Num	ND	NC	PT	PS	
10.080	Stop Motor	Off (0) or On (1)				RO	Bit	ND	NC	PT		
10.081	Phase Loss	Off (0) or On (1)				RO	Bit	ND	NC	PT		
10.101	Drive Status	Inhibit (0), Ready (1), Stop (2), Scan (3), Run (4), Supply Loss (5), Deceleration (6), dc Injection (7), Position (8), Trip (9), Active (10), Off (11), Hand (12), Auto (13), Heat (14), Under Voltage (15), Phasing (16)				RO	Txt	ND	NC	PT		
10.102	Trip Reset Source	0 to 1023				RO	Num	ND	NC	PT	PS	
10.103	Trip Time Identifier	-2147483648 to 2147483647 ms				RO	Num	ND	NC	PT		
10.104	Active Alarm	None (0), Brake Resistor (1), Motor Overload (2), Ind Overload (3), Drive Overload (4), Auto Tune (5), Limit Switch (6), Fire Mode (7), Low Load (8), Option Slot 1 (9), Option Slot 2 (10), Option Slot 3 (11), Option Slot 4 (12)				RO	Txt	ND	NC	PT		
10.105	Hand Off Auto State	Not Active (0), Off (1), Hand (2), Auto (3)				RO	Txt	ND	NC	PT	PS	
10.106	Potential Drive Damage Conditions	0000 to 1111				RO	Bin	ND	NC	PT	PS	
10.107	Auto-tune State	Not Active (0), Resistance (1), pLs (2), Ls (3), Flux (4), Flux Repeat (5), Ld Lq No-load (6), Lq (7), Ke (8), Inertia (9)				RO	Txt	ND	NC	PT		

RW	Read / Write	RO	Read only	Num	Number parameter	Bit	Bit parameter	Txt	Text string	Bin	Binary parameter	FI	Filtered
ND	No default value	NC	Not copied	PT	Protected parameter	RA	Rating dependent	US	User save	PS	Power-down save	DE	Destination
IP	IP address	Mac	Mac address	Date	Date parameter	Time	Time parameter	SMP	Slot,menu,parameter	Chr	Character parameter	Ver	Version number

## 12.12 Menu 11: General drive set-up

Parameter	Range(⌘)		Default(⇨)			Type								
	OL	RFC-A / S	OL	RFC-A	RFC-S									
11.001	Option Synchronisation Select		Not Active (0), Slot 1 (1), Slot 2 (2), Slot 3 (3), Slot 4 (4), Automatic (5)			Slot 3 (3)			RW	Txt				US
11.002	Option synchronisation Active		Not Active (0), Slot 1 (1), Slot 2 (2), Slot 3 (3), Slot 4 (4)						RO	Txt	ND	NC	PT	
11.017	Keypad Defined Node Address		0.000 to 255						RO	Num				
11.018	Status Mode Parameter 1		0.000 to 59.999			0.000			RW	Num			PT	US
11.019	Status Mode Parameter 2		0.000 to 59.999			0.000			RW	Num			PT	US
11.021	Parameter 00.030 Scaling		0.000 to 10.000			1.000			RW	Num				US
11.022	Parameter Displayed At Power-up		0.000 to 0.080			0.010			RW	Num			PT	US
11.028	Drive Derivative		0 to 255						RO	Num	ND	NC	PT	
11.029	Software Version		00.00.00.00 to 99.99.99.99						RO	Num	ND	NC	PT	
11.030	User Security Code		0 to 2147483647			0			RW	Num	ND	NC	PT	US
11.031	User Drive Mode		Open-loop (1), RFC-A (2), RFC-S (3), Regen (4)			Open-loop (1)	RFC-A (2)	RFC-S (3)	RW	Txt	ND	NC	PT	
11.032	Maximum Heavy Duty Rating		0.000 to 99999.999 A						RO	Num	ND	NC	PT	
11.033	Drive Rated Voltage		200 V (0), 400 V (1)						RO	Txt	ND	NC	PT	
11.034	Software Sub Version		0 to 99						RO	Num	ND	NC	PT	
11.036	NV Media Card File Previously Loaded		0 to 999						RO	Num		NC	PT	
11.037	NV Media Card File Number		0 to 999			0			RW	Num				
11.038	NV Media Card File Type		None (0), Open-loop (1), RFC-A (2), RFC-S (3), Regen (4), User Prog (5), Option App (6)						RO	Txt	ND	NC	PT	
11.039	NV Media Card File Version		0 to 9999						RO	Num	ND	NC	PT	
11.040	NV Media Card File Checksum		-2147483648 to 2147483647						RO	Num	ND	NC	PT	
11.042	Parameter Cloning		None (0), Read (1), Program (2), Auto (3), Boot (4)			None (0)			RW	Txt		NC		US
11.043	Load Defaults		None (0), Standard (1), US (2)			None (0)			RW	Txt		NC		
11.044	User Security Status		Menu 0 (0), All Menus (1), Read-only Menu 0 (2), Read-only (3), Status Only (4), No Access (5)			All menus (1)			RW	Txt	ND		PT	
11.045	Select Motor 2 Parameters		Motor 1 (0) or Motor 2 (1)			Motor 1 (0)			RW	Txt				US
11.046	Defaults Previously Loaded		0 to 2000						RO	Num	ND	NC	PT	US
11.047	Onboard User Program: Enable		Reset and Run (-1), Stop (0) or Run (1)			Run (1)			RW	Txt				US
11.048	Onboard User Program: Status		-2147483648 to 2147483647						RO	Num	ND	NC	PT	
11.049	Onboard User Program: Programming Events		0 to 65535						RO	Num	ND	NC	PT	
11.050	Onboard User Program: Freewheeling Tasks Per Second		0 to 65535						RO	Num	ND	NC	PT	
11.051	Onboard User Program: Clock Task Time Used		0.0 to 100.0 %						RO	Num	ND	NC	PT	
11.052	Serial Number LS		000000000 to 999999999						RO	Num	ND	NC	PT	
11.053	Serial Number MS		0 to 999999999						RO	Num	ND	NC	PT	
11.054	Drive Date Code		0 to 65535						RO	Num	ND	NC	PT	
11.055	Onboard User Program: Clock Task Scheduled Interval		0 to 262140 ms						RO	Num	ND	NC	PT	
11.060	Maximum Rated Current		0.000 to 99999.999 A						RO	Num	ND	NC	PT	
11.061	Full Scale Current Kc		0.000 to 99999.999 A						RO	Num	ND	NC	PT	
11.062	Power Board Software Version Number		0.00 to 99.99						RO	Num	ND	NC	PT	
11.063	Product Type		0 to 255						RO	Num	ND	NC	PT	
11.064	Product Identifier Characters		M750						RO	Chr	ND	NC	PT	
11.065	Drive Rating And Configuration		00000000 to 999999999						RO	Num	ND	NC	PT	
11.066	Power Stage Identifier		0 to 255						RO	Num	ND	NC	PT	
11.067	Control Board Identifier		0.000 to 65.535						RO	Num	ND	NC	PT	
11.068	Internal I/O Identifier		0 to 255						RO	Num	ND	NC	PT	
11.069	Position Feedback Interface Identifier		0 to 255						RO	Num	ND	NC	PT	
11.070	Core Parameter Database Version		0.00 to 99.99						RO	Num	ND	NC	PT	
11.072	NV Media Card Create Special File		0 to 1			0			RW	Num		NC		
11.073	NV Media Card Type		None (0), SMART Card (1), SD Card (2)						RO	Txt	ND	NC	PT	
11.075	NV Media Card Read-only Flag		Off (0) or On (1)						RO	Bit	ND	NC	PT	
11.076	NV Media Card Warning Suppression Flag		Off (0) or On (1)						RO	Bit	ND	NC	PT	
11.077	NV Media Card File Required Version		0 to 9999			0			RW	Num	ND	NC	PT	

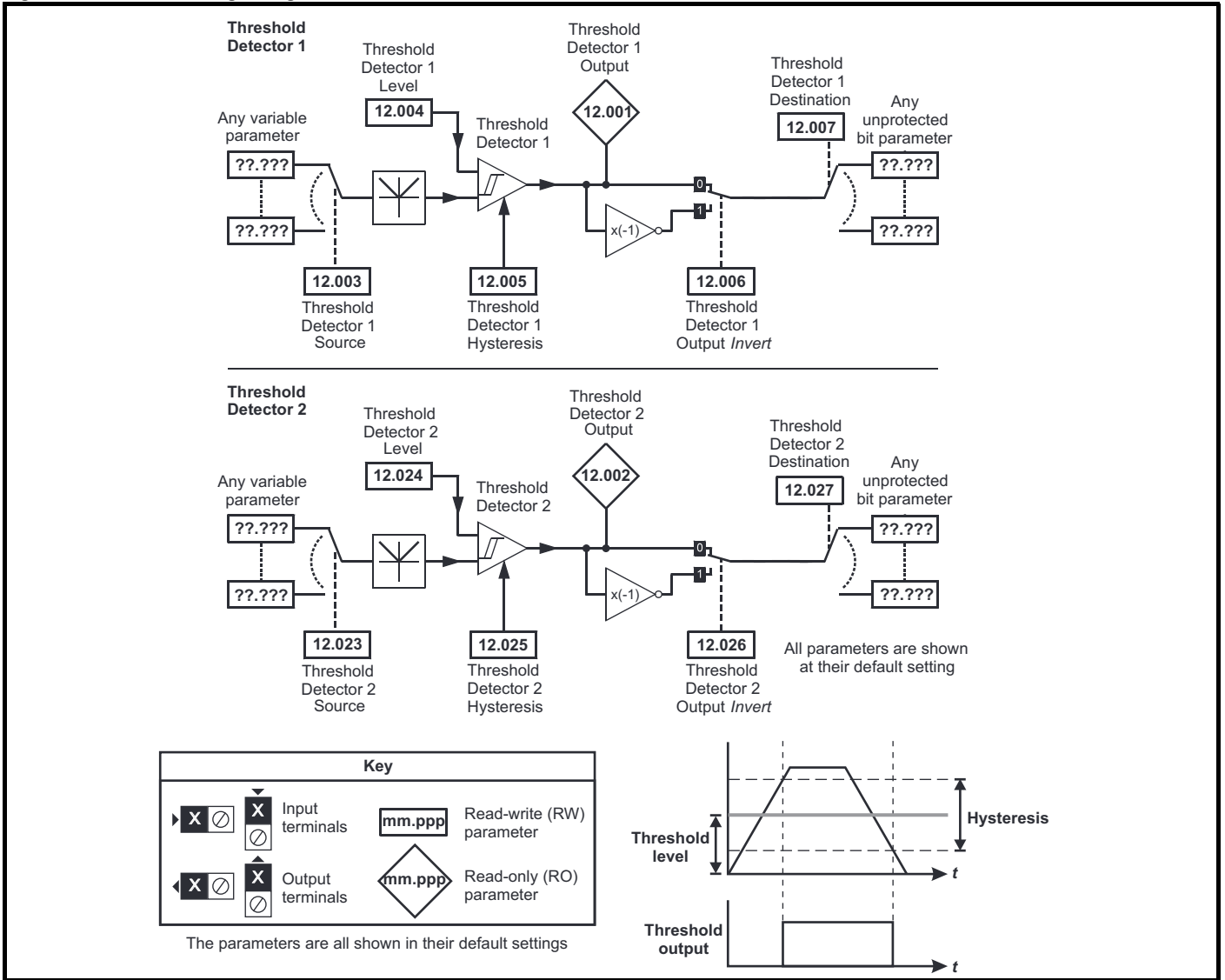
Safety information	Product information	Mechanical installation	Electrical installation	Getting started	Basic parameters	Running the motor	Optimization	Drive communication	SD Card Operation	Onboard PLC	<b>Advanced parameters</b>	Diagnostics	UL listing information
--------------------	---------------------	-------------------------	-------------------------	-----------------	------------------	-------------------	--------------	---------------------	-------------------	-------------	----------------------------	-------------	------------------------

Parameter	Range(⇅)		Default(⇒)			Type								
	OL	RFC-A / S	OL	RFC-A	RFC-S									
11.079	Drive Name Characters 1-4		---- (-2147483648) to --- (2147483647)			---- (0)			RW	Chr			PT	US
11.080	Drive Name Characters 5-8		---- (-2147483648) to --- (2147483647)			---- (0)			RW	Chr			PT	US
11.081	Drive Name Characters 9-12		---- (-2147483648) to --- (2147483647)			---- (0)			RW	Chr			PT	US
11.082	Drive Name Characters 13-16		---- (-2147483648) to --- (2147483647)			---- (0)			RW	Chr			PT	US
11.084	Drive Mode		Open-loop (1), RFC-A (2), RFC-S (3), Regen (4)						RO	Txt	ND	NC	PT	US
11.085	Security Status		None (0), Read-only (1), Status-only (2), No Access (3)						RO	Txt	ND	NC	PT	PS
11.086	Menu Access Status		Menu 0 (0) or All Menus (1)						RO	Txt	ND	NC	PT	PS
11.090	Keypad Port Serial Address		1 to 16			1			RW	Num				US
11.091	Additional Identifier Characters 1		---- (-2147483648) to ---- (2147483647)						RO	Chr	ND	NC	PT	
11.092	Additional Identifier Characters 2		---- (-2147483648) to ---- (2147483647)						RO	Chr	ND	NC	PT	
11.093	Additional Identifier Characters 3		---- (-2147483648) to ---- (2147483647)			101-			RO	Txt	ND	NC	PT	

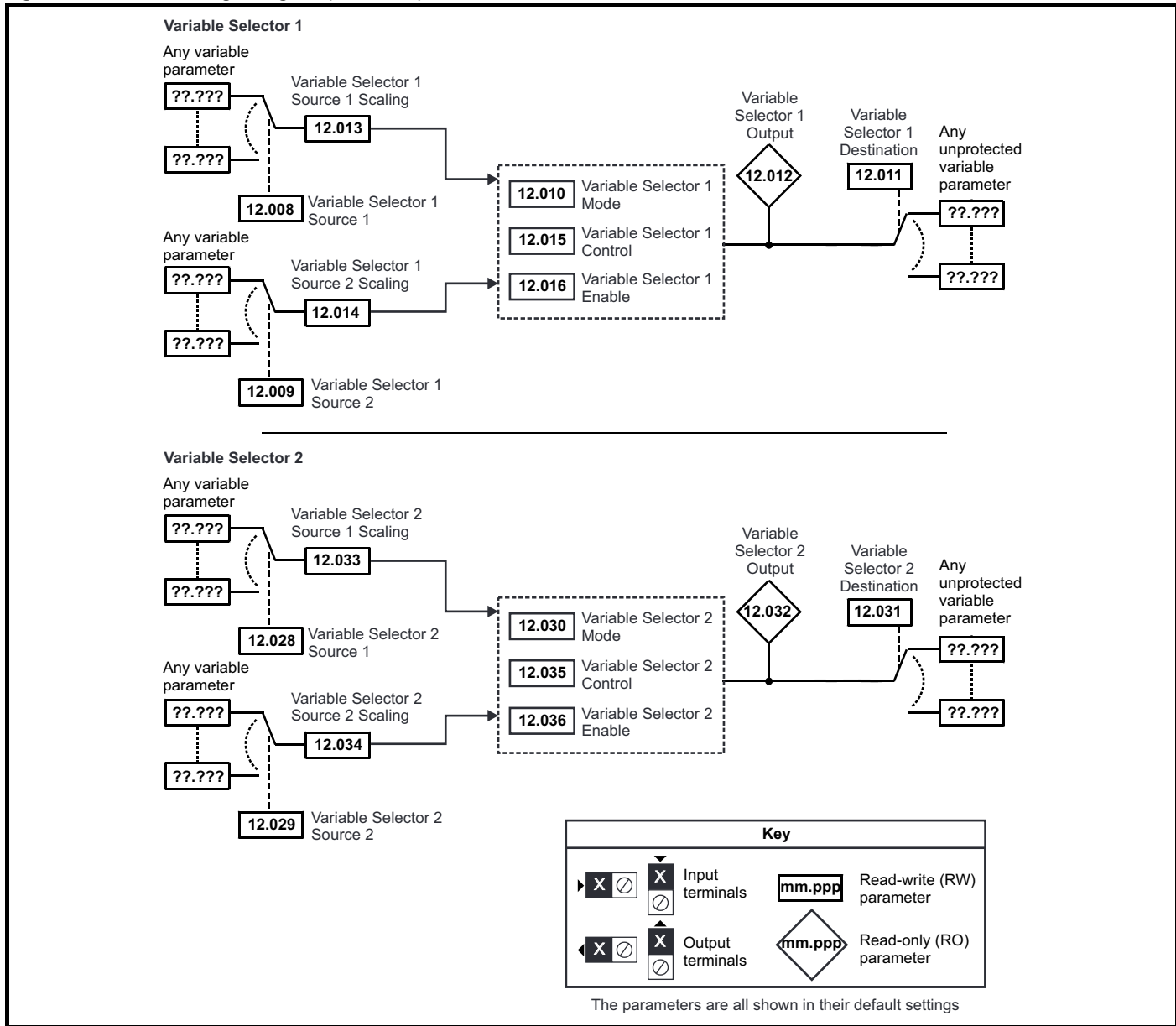
RW	Read / Write	RO	Read only	Num	Number parameter	Bit	Bit parameter	Txt	Text string	Bin	Binary parameter	FI	Filtered
ND	No default value	NC	Not copied	PT	Protected parameter	RA	Rating dependent	US	User save	PS	Power-down save	DE	Destination
IP	IP address	Mac	Mac address	Date	Date parameter	Time	Time parameter	SMP	Slot,menu,parameter	Chr	Character parameter	Ver	Version number

## 12.13 Menu 12: Threshold detectors, variable selectors and brake control function

Figure 12-25 Menu 12 logic diagram

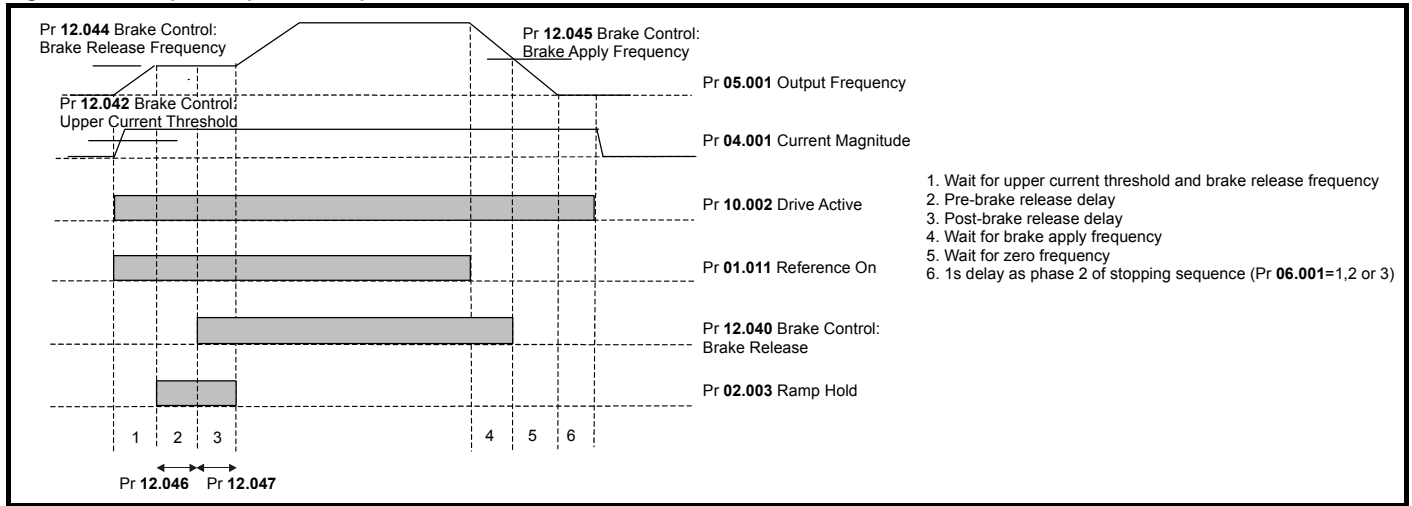


**Figure 12-26 Menu 12 logic diagram (continued)**





**Figure 12-28 Open-loop brake sequence**



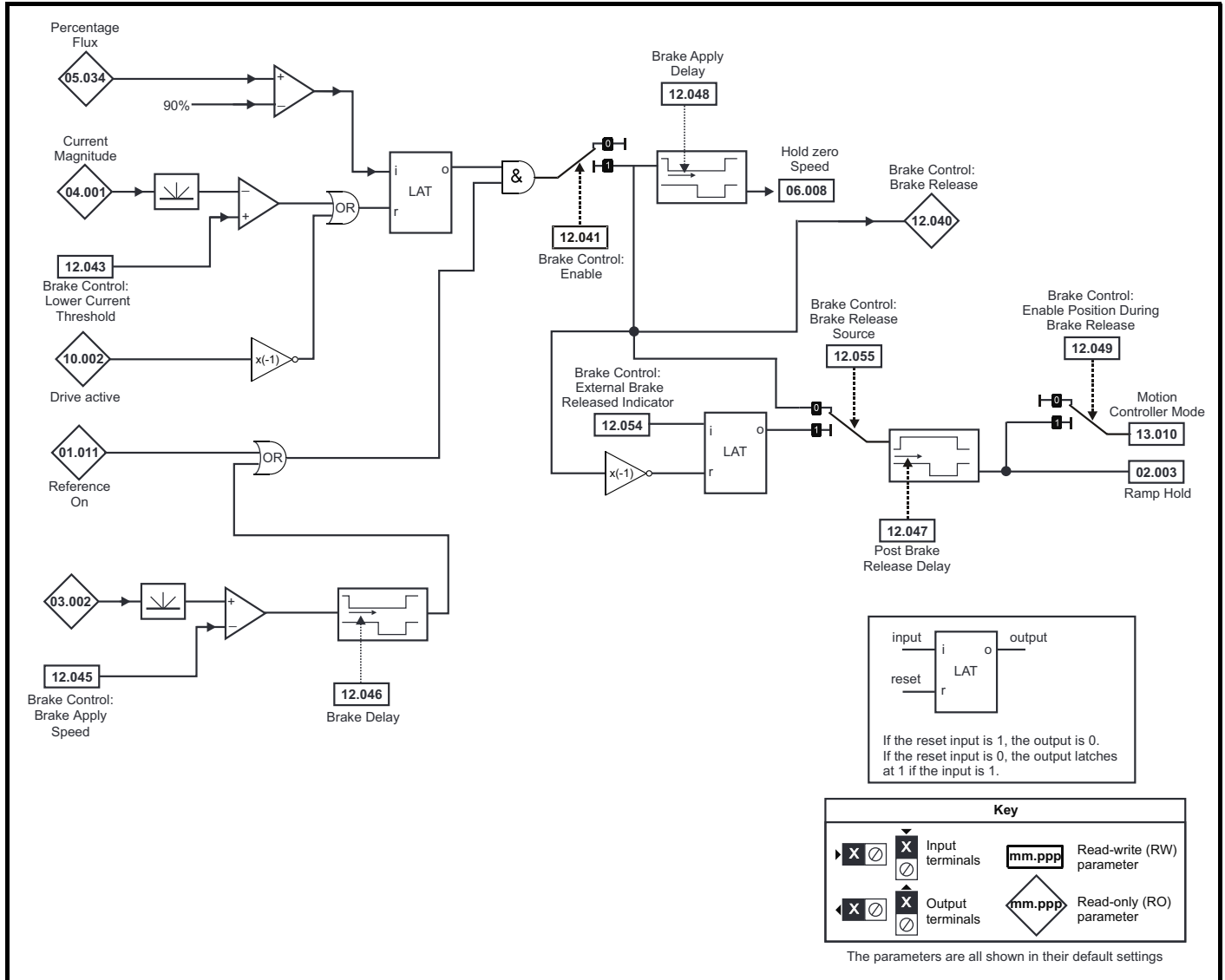


The brake control functions are provided to allow well co-ordinated operation of an external brake with the drive. While both hardware and software are designed to high standards of quality and robustness, they are not intended for use as safety functions, i.e. where a fault or failure would result in a risk of injury. In any application where the incorrect operation of the brake release mechanism could result in injury, independent protection devices of proven integrity must also be incorporated.

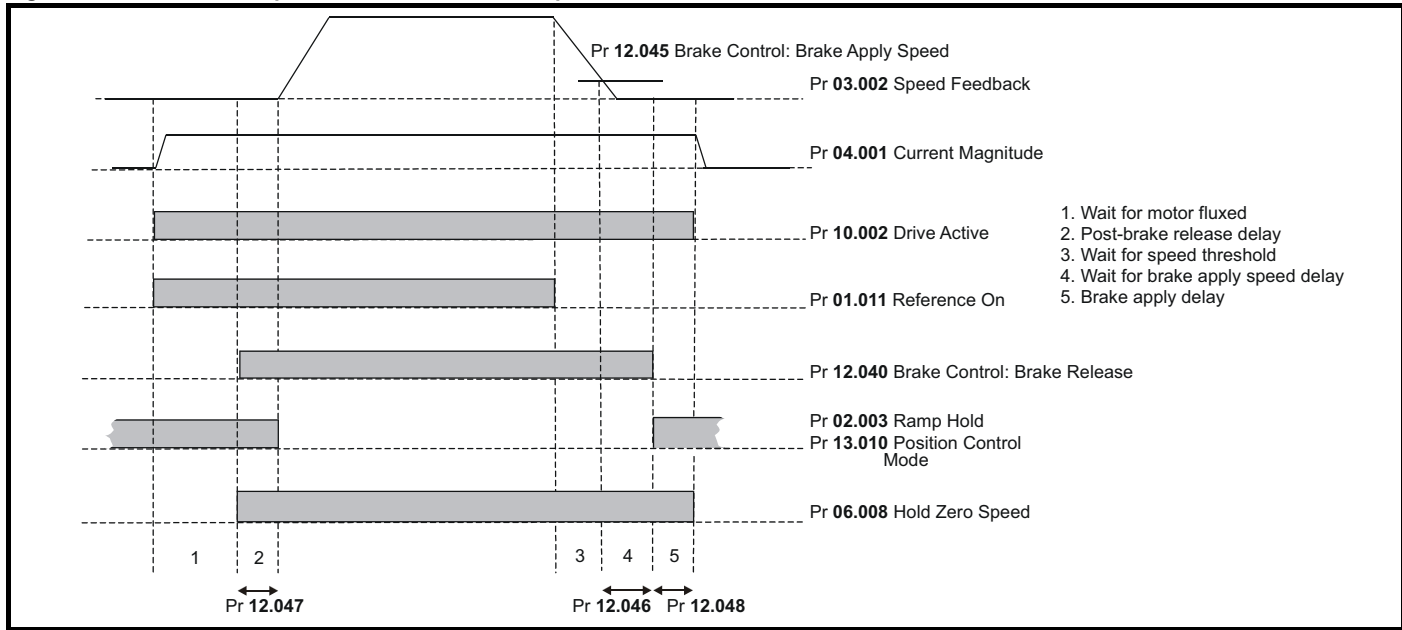


Digital Output 2 in default configuration is selected as an output to release a brake. When drive terminals are programmed to non default settings the result of incorrect or delayed programming must be considered as this may result in the brake being released inadvertently.

**Figure 12-29 RFC-A mode with brake controller mode (12.052) =0 (RFC-A with position feedback mode)**



**Figure 12-30 RFC-A with position feedback brake sequence**



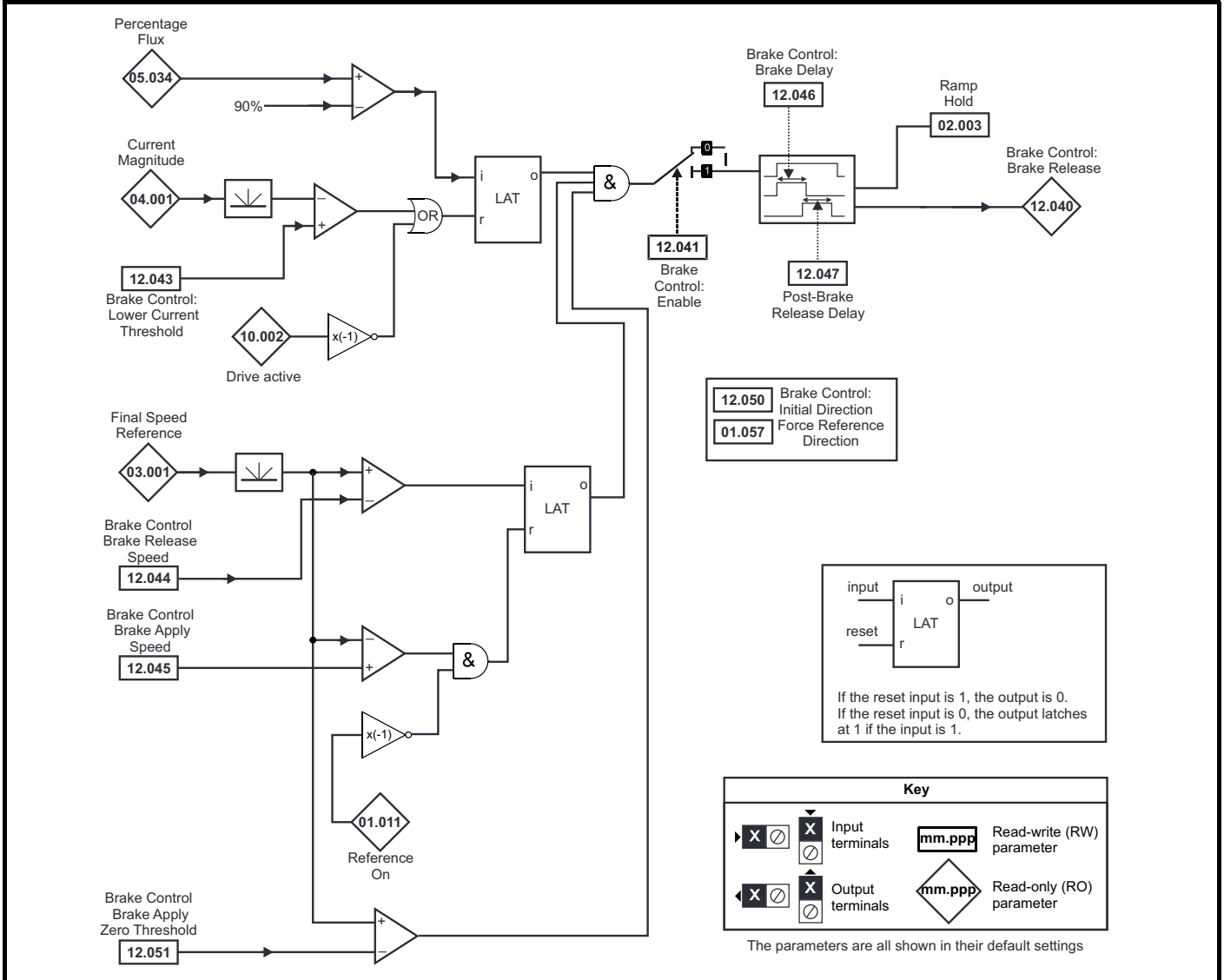


The brake control functions are provided to allow well co-ordinated operation of an external brake with the drive. While both hardware and software are designed to high standards of quality and robustness, they are not intended for use as safety functions, i.e. where a fault or failure would result in a risk of injury. In any application where the incorrect operation of the brake release mechanism could result in injury, independent protection devices of proven integrity must also be incorporated.



Digital Output 2 in default configuration is selected as an output to release a brake. When drive terminals are programmed to non default settings the result of incorrect or delayed programming must be considered as this may result in the brake being released inadvertently.

**Figure 12-31 RFC-A mode with brake controller mode (12.052) =1 (RFC-A Sensorless mode)**



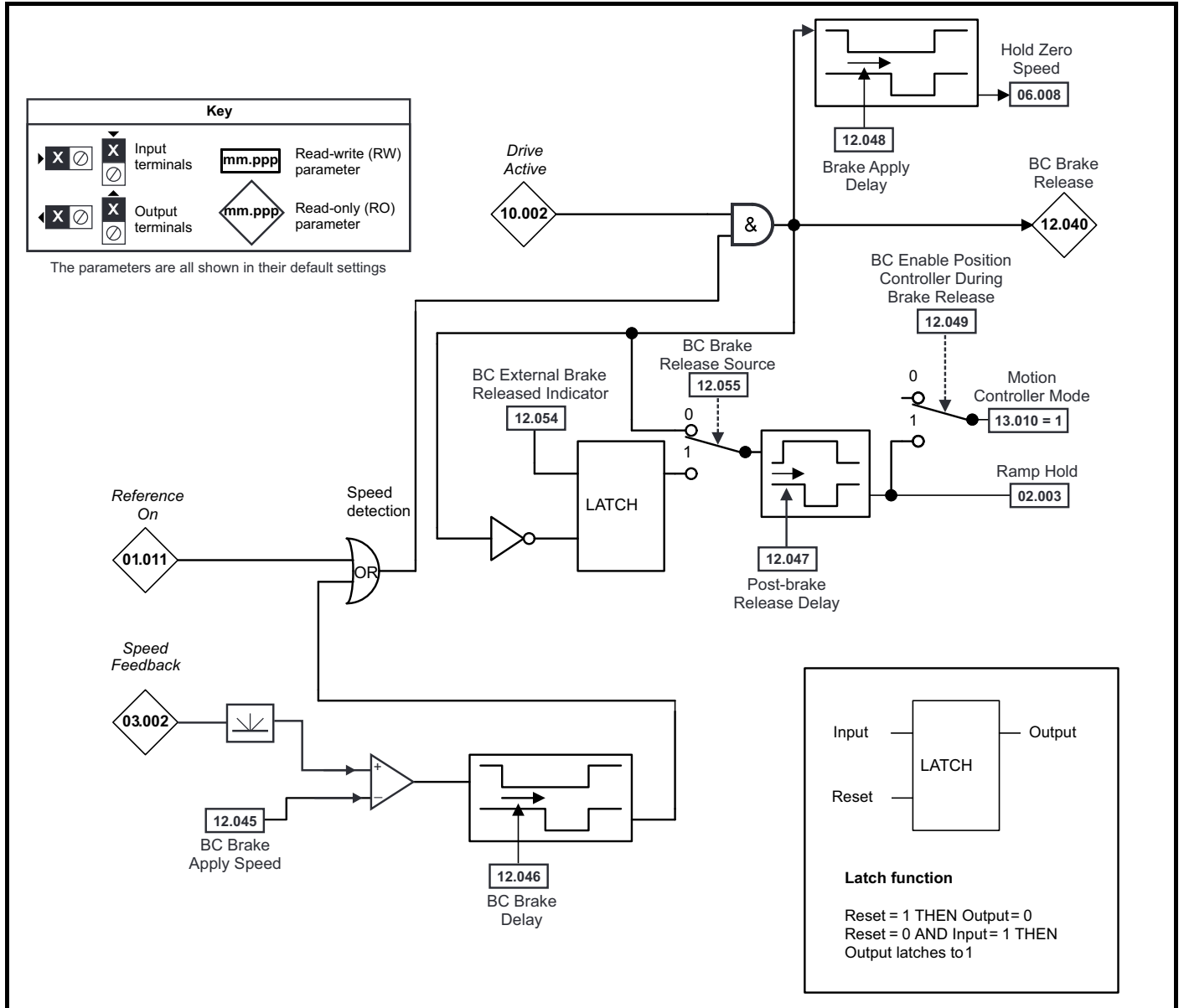


The brake control functions are provided to allow well co-ordinated operation of an external brake with the drive. While both hardware and software are designed to high standards of quality and robustness, they are not intended for use as safety functions, i.e. where a fault or failure would result in a risk of injury. In any application where the incorrect operation of the brake release mechanism could result in injury, independent protection devices of proven integrity must also be incorporated.



Digital Output 2 in default configuration is selected as an output to release a brake. When drive terminals are programmed to non default settings the result of incorrect or delayed programming must be considered as this may result in the brake being released inadvertently.

**Figure 12-32 RFC-S brake function**



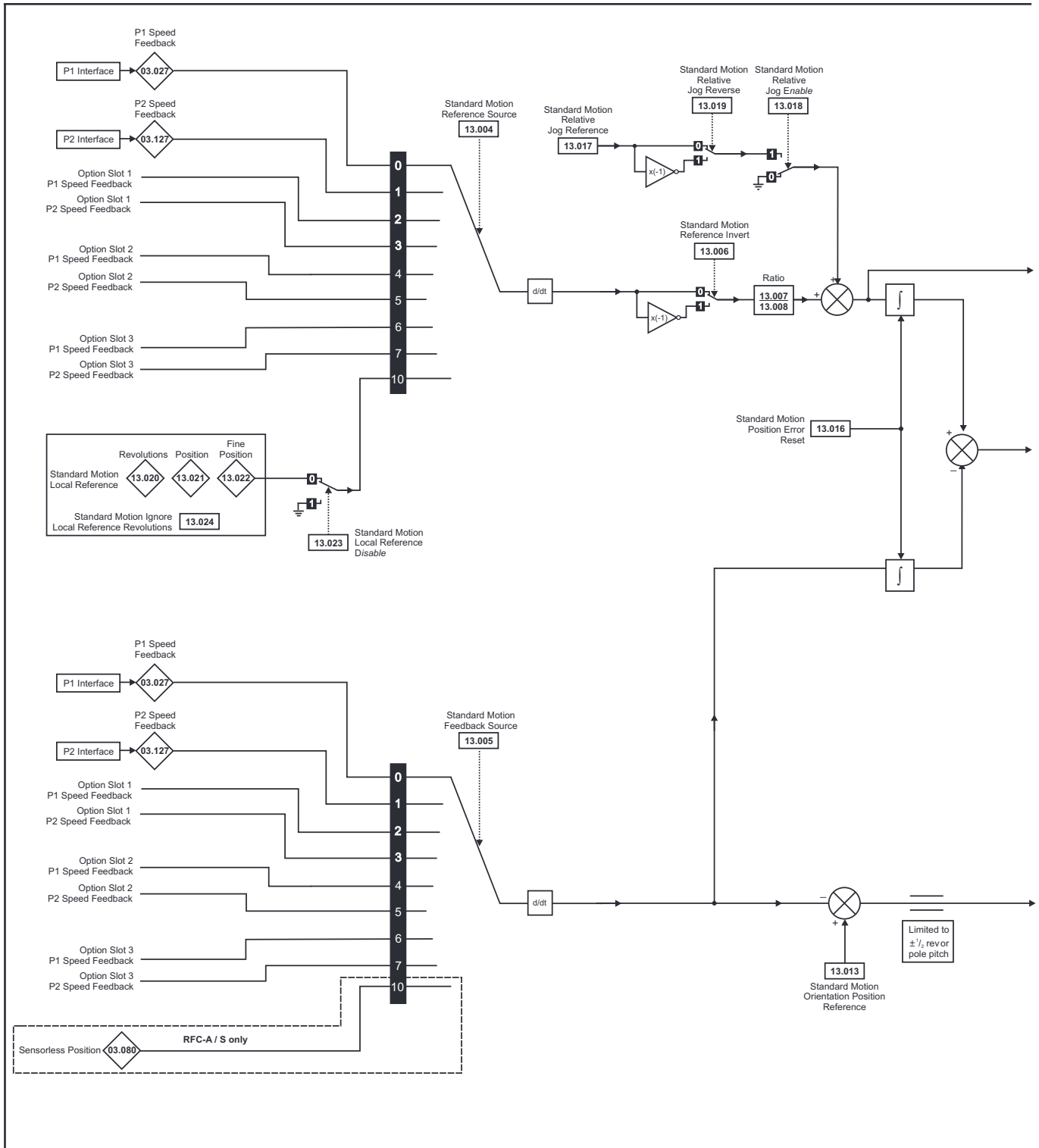
Parameter	Range(⌀)			Default(⇔)			Type					
	OL	RFC- A	RFC- S	OL	RFC-A	RFC-S	RO	Bit	ND	NC	PT	US
12.001	Threshold Detector 1 Output			Off (0) or On (1)			RO	Bit	ND	NC	PT	
12.002	Threshold Detector 2 Output			Off (0) or On (1)			RO	Bit	ND	NC	PT	
12.003	Threshold Detector 1 Source			0.000 to 59.999				Num			PT	US
12.004	Threshold Detector 1 Level			0.00 to 100.00 %				Num				US
12.005	Threshold Detector 1 Hysteresis			0.00 to 25.00 %				Num				US
12.006	Threshold Detector 1 Output Invert			Off (0) or On (1)				Bit				US
12.007	Threshold Detector 1 Destination			0.000 to 59.999				Num	DE		PT	US
12.008	Variable Selector 1 Source 1			0.000 to 59.999				Num			PT	US
12.009	Variable Selector 1 Source 2			0.000 to 59.999				Num			PT	US
12.010	Variable Selector 1 Mode			Input 1 (0), Input 2 (1), Add (2), Subtract (3), Multiply (4), Divide (5), Time Const (6), Ramp (7), Modulus (8), Powers (9), Sectional (10)				Txt				US
12.011	Variable Selector 1 Destination			0.000 to 59.999				Num	DE		PT	US
12.012	Variable Selector 1 Output			±100.00 %			RO	Num	ND	NC	PT	
12.013	Variable Selector 1 Source 1 Scaling			±4.000				Num				US
12.014	Variable Selector 1 Source 2 Scaling			±4.000				Num				US
12.015	Variable Selector 1 Control			0.00 to 100.00				Num				US
12.016	Variable Selector 1 Enable			Off (0) or On (1)				Bit				US
12.023	Threshold Detector 2 Source			0.000 to 59.999				Num			PT	US
12.024	Threshold Detector 2 Level			0.00 to 100.00 %				Num				US
12.025	Threshold Detector 2 Hysteresis			0.00 to 25.00 %				Num				US
12.026	Threshold Detector 2 Output Invert			Off (0) or On (1)				Bit				US
12.027	Threshold Detector 2 Destination			0.000 to 59.999				Num	DE		PT	US
12.028	Variable Selector 2 Source 1			0.000 to 59.999				Num			PT	US
12.029	Variable Selector 2 Source 2			0.000 to 59.999				Num			PT	US
12.030	Variable Selector 2 Mode			Input 1 (0), Input 2 (1), Add (2), Subtract (3), Multiply (4), Divide (5), Time Const (6), Ramp (7), Modulus (8), Powers (9), Sectional (10)				Txt				US
12.031	Variable Selector 2 Destination			0.000 to 59.999				Num	DE		PT	US
12.032	Variable Selector 2 Output			±100.00 %			RO	Num	ND	NC	PT	
12.033	Variable Selector 2 Source 1 Scaling			±4.000				Num				US
12.034	Variable Selector 2 Source 2 Scaling			±4.000				Num				US
12.035	Variable Selector 2 Control			0.00 to 100.00				Num				US
12.036	Variable Selector 2 Enable			Off (0) or On (1)				Bit				US
12.040	Brake Control: Brake Release			Off (0) or On (1)			RO	Bit	ND	NC	PT	
12.041	Brake Control: Enable			Off (0) or On (1)				Bit				US
12.042	Brake Control: Upper Current Threshold			0 to 200 %			50 %					US
12.043	Brake Control: Lower Current Threshold			0 to 200 %				10 %				US
12.044	Brake Control: Brake Release Frequency			0.0 to 20.0 Hz			1.0 Hz					US
	Brake Control: Brake Release Speed			0 to 200 rpm			10 rpm					US
12.045	Brake Control: Brake Apply Frequency			0.0 to 20.0 Hz			2.0 Hz					US
	Brake Control: Brake Apply Speed			0 to 200 rpm			5 rpm					US
12.046	Brake Control: Brake Delay			0.0 to 25.0 s			1.0 s					US
12.047	Brake Control: Post-brake Release Delay			0.0 to 25.0 s			1.0 s					US
12.048	Brake Control: Brake Apply Delay			0.0 to 25.0 s			1.0 s					US
12.049	Brake Control: Enable Position Control During Brake Release			Off (0) or On (1)			Off (0)					US
12.050	Brake Control: Initial Direction			Ref (0), Forward (1), Reverse (2)			Ref (0)					US
12.051	Brake Control: Brake Apply Through Zero Threshold			0.0 to 20.0 Hz	0 to 200 rpm		1.0 Hz	5 rpm				US
12.052	Brake Control: Mode			Off (0) or On (1)			Off (0)					US
12.054	External Brake Released Indicator			Off (0) or On (1)			Off (0)					US
12.055	Brake Release Source			Off (0) or On (1)			Off (0)					US

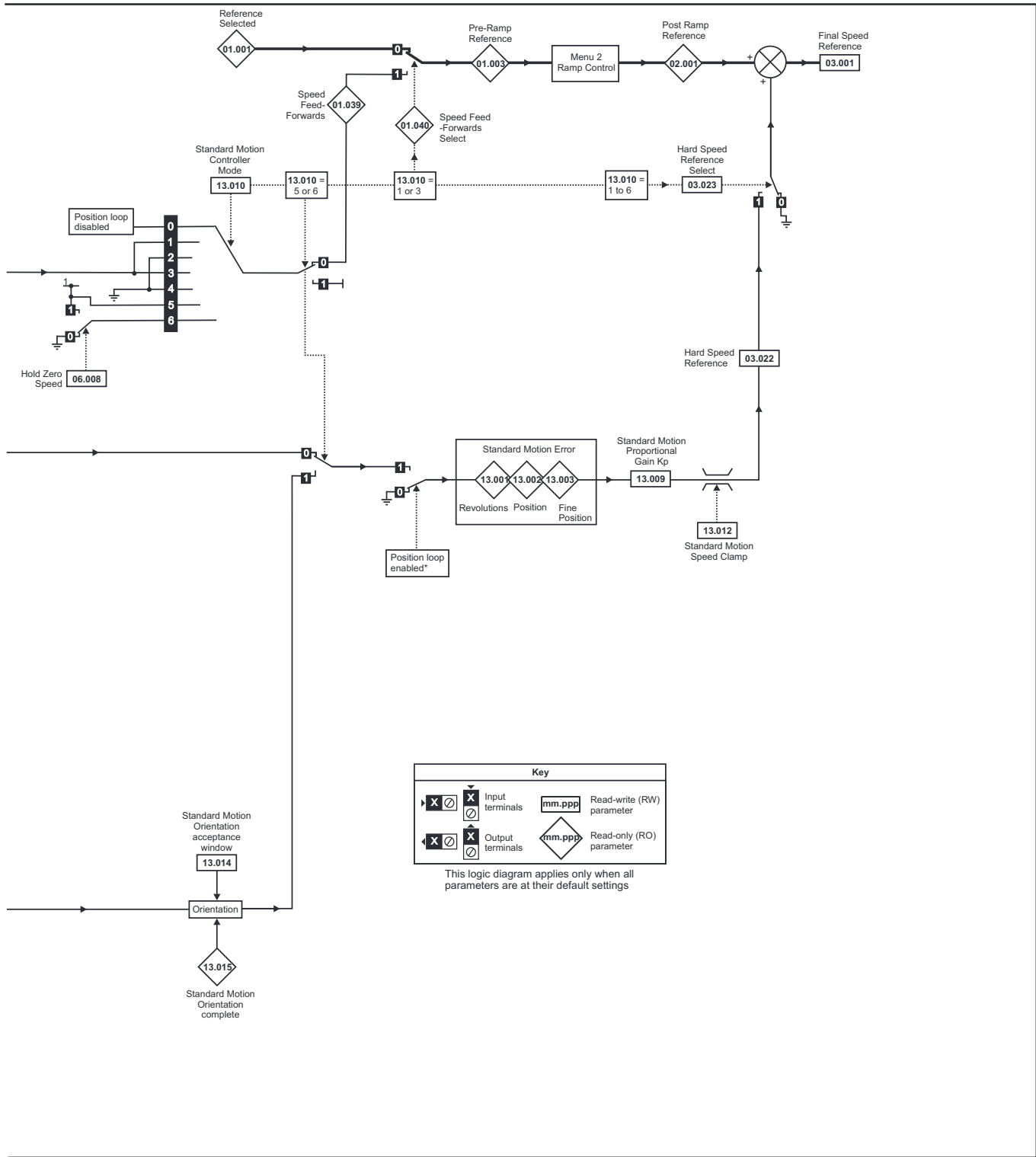
RW	Read / Write	RO	Read only	Num	Number parameter	Bit	Bit parameter	Txt	Text string	Bin	Binary parameter	FI	Filtered
ND	No default value	NC	Not copied	PT	Protected parameter	RA	Rating dependent	US	User save	PS	Power-down save	DE	Destination

Safety information	Product information	Mechanical installation	Electrical installation	Getting started	Basic parameters	Running the motor	Optimization	Drive communication	SD Card Operation	Onboard PLC	<b>Advanced parameters</b>	Diagnostics	UL listing information
--------------------	---------------------	-------------------------	-------------------------	-----------------	------------------	-------------------	--------------	---------------------	-------------------	-------------	----------------------------	-------------	------------------------

## 12.14 Menu 13: Standard motion controller

Figure 12-33 Menu 13 logic diagram





\*The position controller is disabled and the error integrator is also reset under the following conditions:

1. If the drive is disabled (i.e. inhibited, ready or tripped)
2. If the position controller mode (Pr 13.010) is changed. The position controller is disabled transiently to reset the error integrator.
3. The absolute mode parameter (Pr 13.011) is changed. The position controller is disabled transiently to reset the error integrator.
4. One of the position sources is invalid.
5. The position feedback initialized parameter (Pr 03.048) is zero.

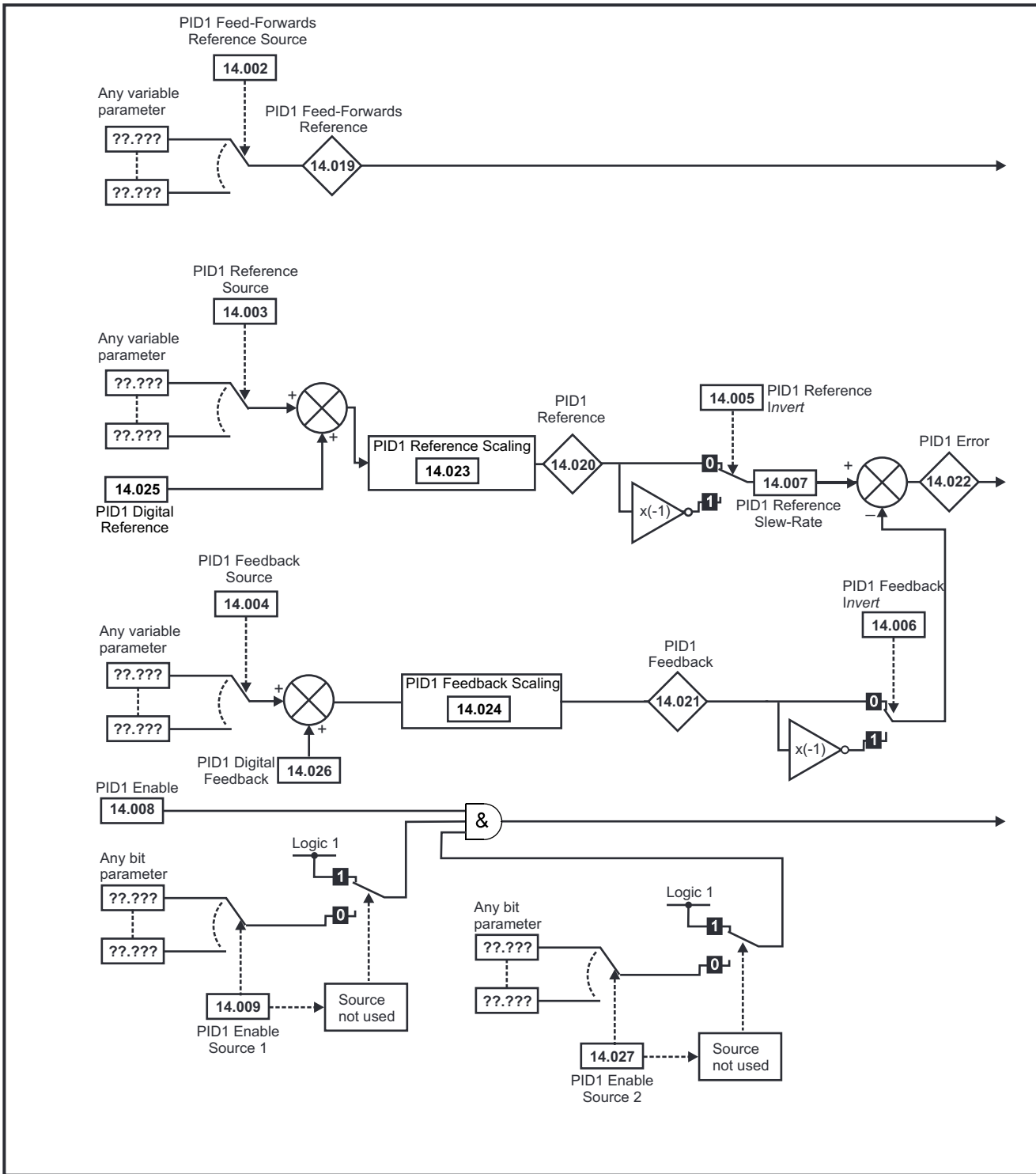
Parameter	Range(⌘)		Default(⇔)			Type						
	OL	RFC-A / S	OL	RFC-A	RFC-S							
13.001	Standard Motion Revolutions Error	-32768 to 32767 revs				RO	Num	ND	NC	PT		
13.002	Standard Motion Position Error	-32768 to 32767				RO	Num	ND	NC	PT		
13.003	Standard Motion Fine Position Error	-32768 to 32767				RO	Num	ND	NC	PT		
13.004	Standard Motion Reference Source	P1 Drive (0), P2 Drive (1), P1 Slot 1 (2), P2 Slot 1 (3), P1 Slot 2 (4), P2 Slot 2 (5), Local (10)		P1 Drive (0)			RW	Txt				US
13.005	Standard Motion Feedback Source	P1 Drive (0), P2 Drive (1), P1 Slot 1 (2), P2 Slot 1 (3), P1 Slot 2 (4), P2 Slot 2 (5)	P1 Drive (0), P2 Drive (1), P1 Slot 1 (2), P2 Slot 1 (3), P1 Slot 2 (4), P2 Slot 2 (5), Sensorless (10)	P1 Drive (0)			RW	Txt				US
13.006	Standard Motion Reference Invert	Off (0) or On (1)		Off (0)			RW	Bit				US
13.007	Standard Motion Ratio Numerator	0.000 to 10.000		1.000			RW	Num				US
13.008	Standard Motion Ratio Denominator	0.000 to 4.000		1.000			RW	Num				US
13.009	Standard Motion Proportional Gain Kp	0.00 to 100.00		25.00			RW	Num				US
13.010	Standard Motion Controller Mode	Disabled (0), Rigid Spd FF (1), Rigid (2), Non-rigid Spd FF(3), Non-Rigid (4)	Disabled (0), Rigid Spd FF (1), Rigid (2), Non-rigid Spd FF (3), Non-Rigid (4), Orientate Stop (5), Orientate (6)	Disabled (0)			RW	Txt				US
13.011	Standard Motion Absolute Mode Enable	Off (0) or On (1)		Off (0)			RW	Bit				US
13.012	Standard Motion Speed Clamp	0 to 250 rpm		150 rpm			RW	Num				US
13.013	Standard Motion Orientation Position Reference	0 to 65535		0			RW	Num				US
13.014	Standard Motion Orientation Acceptance Window	0 to 4096		256			RW	Num				US
13.015	Standard Motion Orientation Complete	Off (0) or On (1)					RO	Bit	ND	NC	PT	
13.016	Standard Motion Position Error Reset	Off (0) or On (1)		Off (0)			RW	Bit		NC		
13.017	Standard Motion Relative Jog Reference	0.0 to 4000.0 rpm		0.0 rpm			RW	Num				US
13.018	Standard Motion Relative Jog Enable	Off (0) or On (1)		Off (0)			RW	Bit		NC		
13.019	Standard Motion Relative Jog Reverse	Off (0) or On (1)		Off (0)			RW	Bit		NC		
13.020	Standard Motion Local Reference Revolutions	0 to 65535 revs		0 revs			RW	Num		NC		
13.021	Standard Motion Local Reference Position	0 to 65535		0			RW	Num		NC		
13.022	Standard Motion Local Reference Fine Position	0 to 65535		0			RW	Num		NC		
13.023	Standard Motion Local Reference Disable	Off (0) or On (1)		Off (0)			RW	Bit		NC		
13.024	Standard Motion Ignore Local Reference Revolutions	Off (0) or On (1)		Off (0)			RW	Bit				US
13.026	Standard Motion Sample Rate	Not Active (0), 4ms (1)					RO	Txt				US

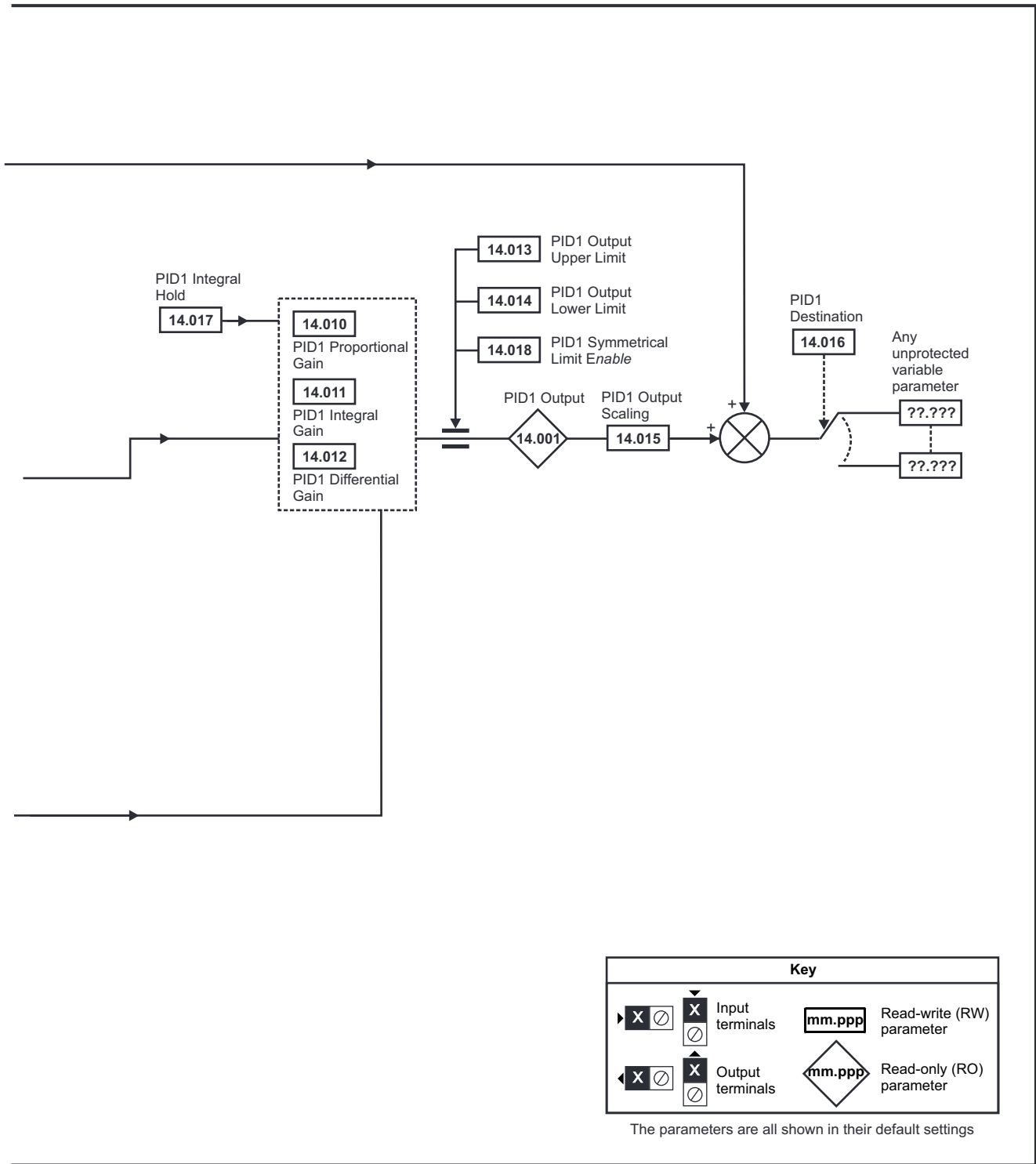
RW	Read / Write	RO	Read only	Num	Number parameter	Bit	Bit parameter	Txt	Text string	Bin	Binary parameter	FI	Filtered
ND	No default value	NC	Not copied	PT	Protected parameter	RA	Rating dependent	US	User save	PS	Power-down save	DE	Destination

Safety information	Product information	Mechanical installation	Electrical installation	Getting started	Basic parameters	Running the motor	Optimization	Drive communication	SD Card Operation	Onboard PLC	<b>Advanced parameters</b>	Diagnostics	UL listing information
--------------------	---------------------	-------------------------	-------------------------	-----------------	------------------	-------------------	--------------	---------------------	-------------------	-------------	----------------------------	-------------	------------------------

## 12.15 Menu 14: User PID controller

Figure 12-34 Menu 14 Logic diagram





**NOTE**

The same logic diagram above (Menu 14) can also be used for PID2 as they are the same.

Parameter	Range(⊕)		Default(⇔)			Type					
	OL	RFC-A / S	OL	RFC-A	RFC-S						
14.001	PID1 Output	±100.00 %				RO	Num	ND	NC	PT	
14.002	PID1 Feed-forwards Reference Source	0.000 to 59.999		0.000		RW	Num			PT	US
14.003	PID1 Reference Source	0.000 to 59.999		0.000		RW	Num			PT	US
14.004	PID1 Feedback Source	0.000 to 59.999		0.000		RW	Num			PT	US
14.005	PID1 Reference Invert	Off (0) or On (1)		Off (0)		RW	Bit				US
14.006	PID1 Feedback Invert	Off (0) or On (1)		Off (0)		RW	Bit				US
14.007	PID1 Reference Slew Rate	0.0 to 3200.0 s		0.0 s		RW	Num				US
14.008	PID1 Enable	Off (0) or On (1)		Off (0)		RW	Bit				US
14.009	PID1 Enable Source 1	0.000 to 59.999		0.000		RW	Num			PT	US
14.010	PID1 Proportional Gain	0.000 to 4.000		1.000		RW	Num				US
14.011	PID1 Integral Gain	0.000 to 4.000		0.500		RW	Num				US
14.012	PID1 Differential Gain	0.000 to 4.000		0.000		RW	Num				US
14.013	PID1 Output Upper Limit	0.00 to 100.00 %		100.00 %		RW	Num				US
14.014	PID1 Output Lower Limit	±100.00 %		-100.00 %		RW	Num				US
14.015	PID1 Output Scaling	0.000 to 4.000		1.000		RW	Num				US
14.016	PID1 Destination	0.000 to 59.999		0.000		RW	Num	DE		PT	US
14.017	PID1 Integral Hold	Off (0) or On (1)		Off (0)		RW	Bit				
14.018	PID1 Symmetrical Limit Enable	Off (0) or On (1)		Off (0)		RW	Bit				US
14.019	PID1 Feed-forwards Reference	±100.00 %				RO	Num	ND	NC	PT	
14.020	PID1 Reference	±100.00 %				RO	Num	ND	NC	PT	
14.021	PID1 Feedback	±100.00 %				RO	Num	ND	NC	PT	
14.022	PID1 Error	±100.00 %				RO	Num	ND	NC	PT	
14.023	PID1 Reference Scaling	0.000 to 4.000		1.000		RW	Num				US
14.024	PID1 Feedback Scaling	0.000 to 4.000		1.000		RW	Num				US
14.025	PID1 Digital Reference	±100.00 %		0.00 %		RW	Num				US
14.026	PID1 Digital Feedback	±100.00 %		0.00 %		RW	Num				US
14.027	PID1 Enable Source 2	0.000 to 59.999		0.000		RW	Num			PT	US
14.028	PID1 Pre-sleep Boost Level	0.00 to 100.00 %		0.00 %		RW	Num				US
14.029	PID1 Maximum Boost Time	0.0 to 250.0 s		0.0 s		RW	Num				US
14.030	PID1 Pre-sleep Boost Level Enable	Off (0) or On (1)				RO	Bit	ND	NC	PT	
14.031	PID2 Output	±100.00 %				RO	Num	ND	NC	PT	
14.032	PID2 Feed-forwards Reference Source	0.000 to 59.999		0.000		RW	Num			PT	US
14.033	PID2 Reference Source	0.000 to 59.999		0.000		RW	Num			PT	US
14.034	PID2 Feedback Source	0.000 to 59.999		0.000		RW	Num			PT	US
14.035	PID2 Reference Invert	Off (0) or On (1)		Off (0)		RW	Bit				US
14.036	PID2 Feedback Invert	Off (0) or On (1)		Off (0)		RW	Bit				US
14.037	PID2 Reference Slew Rate Limit	0.0 to 3200.0 s		0.0 s		RW	Num				US
14.038	PID2 Enable	Off (0) or On (1)		Off (0)		RW	Bit				US
14.039	PID2 Enable Source 1	0.000 to 59.999		0.000		RW	Num			PT	US
14.040	PID2 Proportional Gain	0.000 to 4.000		1.000		RW	Num				US
14.041	PID2 Integral Gain	0.000 to 4.000		0.500		RW	Num				US
14.042	PID2 Differential Gain	0.000 to 4.000		0.000		RW	Num				US
14.043	PID2 Output Upper Limit	0.00 to 100.00 %		100.00 %		RW	Num				US
14.044	PID2 Output Lower Limit	±100.00 %		-100.00 %		RW	Num				US
14.045	PID2 Output Scaling	0.000 to 4.000		1.000		RW	Num				US
14.046	PID2 Destination	0.000 to 59.999		0.000		RW	Num	DE		PT	US
14.047	PID2 Integral Hold	Off (0) or On (1)		Off (0)		RW	Bit				
14.048	PID2 Symmetrical Limit Enable	Off (0) or On (1)		Off (0)		RW	Bit				US
14.049	PID2 Feed-forwards Reference	±100.00 %				RO	Num	ND	NC	PT	
14.050	PID2 Reference	±100.00 %				RO	Num	ND	NC	PT	
14.051	PID2 Feedback	±100.00 %				RO	Num	ND	NC	PT	
14.052	PID2 Error	±100.00 %				RO	Num	ND	NC	PT	
14.053	PID2 Reference Scaling	0.000 to 4.000		1.000		RW	Num				US
14.054	PID2 Feedback Scaling	0.000 to 4.000		1.000		RW	Num				US
14.055	PID2 Digital Reference	±100.00 %		0.00 %		RW	Num				US
14.056	PID2 Digital Feedback	±100.00 %		0.00 %		RW	Num				US
14.057	PID2 Enable Source 2	0.000 to 59.999		0.000		RW	Num			PT	US
14.058	PID1 Feedback Output Scaling	0.000 to 4.000		1.000		RW	Num				US

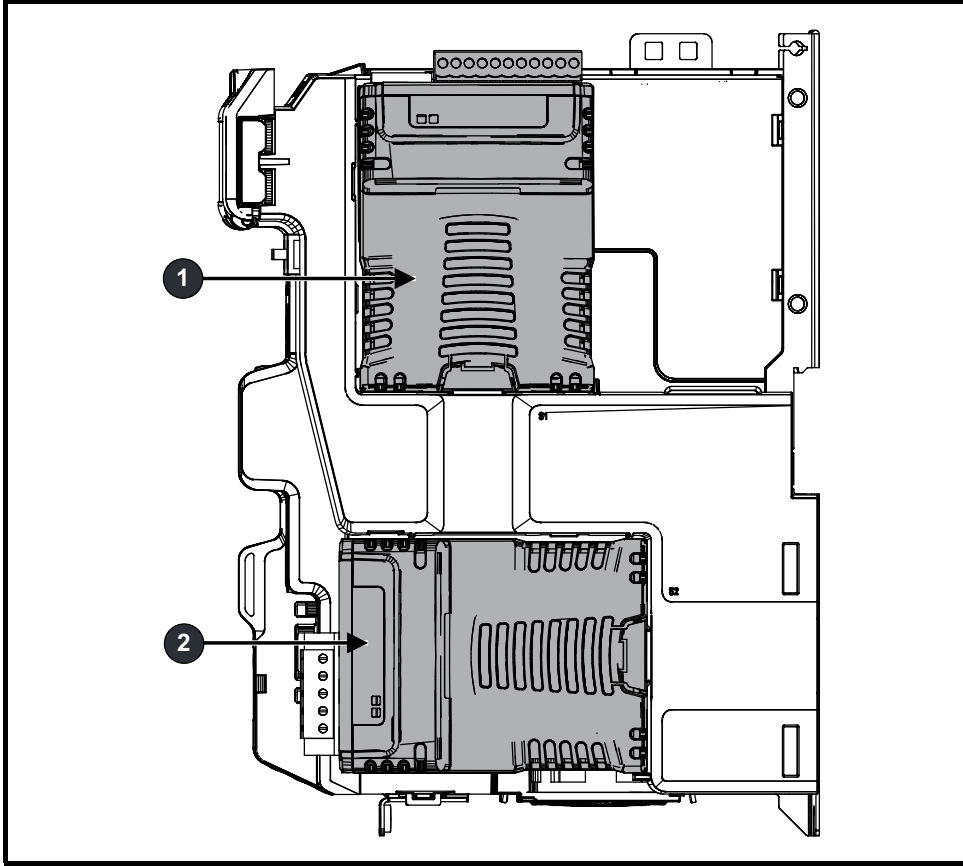
Safety information	Product information	Mechanical installation	Electrical installation	Getting started	Basic parameters	Running the motor	Optimization	Drive communication	SD Card Operation	Onboard PLC	<b>Advanced parameters</b>	Diagnostics	UL listing information
--------------------	---------------------	-------------------------	-------------------------	-----------------	------------------	-------------------	--------------	---------------------	-------------------	-------------	----------------------------	-------------	------------------------

Parameter		Range(⇅)		Default(⇨)			Type						
		OL	RFC-A / S	OL	RFC-A	RFC-S							
14.059	PID1 Mode Selector	Fbk1 (0), Fbk2 (1), Fbk1 + Fbk2 (2), Min Fbk (3), Max Fbk (4), Av Fbk (5), Min Error (6), Max Error (7)		Fbk1 (0)			RW	Txt					US
14.060	PID1 Feedback Square Root Enable 1	Off (0) or On (1)		Off (0)			RW	Bit					US
14.061	PID2 Feedback Square Root Enable	Off (0) or On (1)		Off (0)			RW	Bit					US
14.062	PID1 Feedback Square Root Enable 2	Off (0) or On (1)		Off (0)			RW	Bit					US

RW	Read / Write	RO	Read only	Num	Number parameter	Bit	Bit parameter	Txt	Text string	Bin	Binary parameter	FI	Filtered
ND	No default value	NC	Not copied	PT	Protected parameter	RA	Rating dependent	US	User save	PS	Power-down save	DE	Destination

## 12.16 Menus 15, 16 and 17: Option module set-up

Figure 12-35 Location of option module slots and their corresponding menu numbers



1. Solutions Module Slot 1 - Menu 15
2. Solutions Module Slot 2 - Menu 16

### 12.16.1 Parameters common to all categories

Parameter		Range(⇅)	Default(⇒)	Type					
mm.001	Module ID	0 to 65535		RO	Num	ND	NC	PT	
mm.002	Software Version	00.00.00.00 to 99.99.99.99		RO	Ver	ND	NC	PT	
mm.003	Hardware Version	0.00 to 99.99		RO	Num	ND	NC	PT	
mm.004	Serial Number LS	0 to 99999999		RO	Num	ND	NC	PT	
mm.005	Serial Number MS		RO	Num	ND	NC	PT		
mm.006	Module Status	Initialising (0) to Error (3)		RO	Txt	ND	NC	PT	
mm.007	Module Reset	Off (0) or On (1)	Off (0)	RW	Bit		NC		

The option module ID indicates the type of module that is installed in the corresponding slot. See the relevant option module user guide for more information regarding the module.

Option module ID	Module	Category
0	No module installed	
105	SI-Encoder	Feedback
106	SI-Universal Encoder	
209	SI-I/O	Automation (I/O Expansion)
304	SI-Applications Compact	Automation (Applications)
310	MCi210	
311	MCi200	
431	SI-EtherCAT	Fieldbus
432	SI-PROFINET RT	
433	SI-Ethernet	
434	SI-PROFINET V2	
443	SI-PROFIBUS	
447	SI-DeviceNet	
448	SI-CANopen	

## 12.17 Menus 17: Ethernet Interface - Set-up

Parameter		Range(⌘)		Default(⇔)			Type						
		OL	RFC-A / S	OL	RFC-A	RFC-S							
17.001	Module ID	0 to 65535					RO	Num	ND	NC	PT		
17.002	Software Version	0 to 99999999					RO	Num	ND	NC	PT		
17.003	Hardware version	0.00 to 655.35					RO	Num	ND	NC	PT		
17.004	Serial Number LS	00000000 to 99999999					RO	Num	ND	NC	PT		
17.005	Serial Number MS	0 to 99999999					RO	Num	ND	NC	PT		
17.006	Status	Bootldr - Update (-2), Bootldr - Idle (-1), Initialising (0), OK (1), Config (2), Error (3)					RO	Txt	ND	NC	PT		
17.007	Reset	Off (0) or On (1)				Off (0)	RW	Bit		NC			
17.008	Default	Off (0) or On (1)				Off (0)	RW	Bit		NC			
17.009	Active Alarm Bits	0000000000000000 to 1111111111111111				0000000000000000	RO	Bin		NC			
17.010	Active IP Address	0 to 255				0.0.0.0	RO	IP		NC	PT		

## 12.18 Menu 18: Application menu 1

Parameter		Range(⌘)		Default(⇔)			Type						
		OL	RFC-A / S	OL	RFC-A	RFC-S							
18.001	Application Menu 1 Power-down Save Integer	-32768 to 32767				0	RW	Num					PS
18.002 to 18.010	Application Menu 1 Read-only Integer	-32768 to 32767					RO	Num	ND	NC			US
18.011 to 18.030	Application Menu 1 Read-write Integer	-32768 to 32767				0	RW	Num					US
18.031 to 18.050	Application Menu 1 Read-write bit	Off (0) or On (1)				Off (0)	RW	Bit					US
18.051 to 18.054	Application Menu 1 Power-down Save long Integer	-2147483648 to 2147483647				0	RW	Num					PS

## 12.19 Menu 19: Application menu 2

Parameter		Range(⌘)		Default(⇔)			Type						
		OL	RFC-A / S	OL	RFC-A	RFC-S							
19.001	Application Menu 2 Power-down Save Integer	-32768 to 32767				0	RW	Num					PS
19.002 to 19.010	Application Menu 2 Read-only Integer	-32768 to 32767					RO	Num	ND	NC			US
19.011 to 19.030	Application Menu 2 Read-write Integer	-32768 to 32767				0	RW	Num					US
19.031 to 19.050	Application Menu 2 Read-write bit	Off (0) or On (1)				Off (0)	RW	Bit					US
19.051 to 19.054	Application Menu 2 Power-down Save long Integer	-2147483648 to 2147483647				0	RW	Num					PS

## 12.20 Menu 20: Application menu 3

Parameter		Range(⌘)		Default(⇔)			Type						
		OL	RFC-A / S	OL	RFC-A	RFC-S							
20.001 to 20.020	Application Menu 3 Read-write Integer	-32768 to 32767				0	RW	Num					
20.021 to 20.040	Application Menu 3 Read-write Long Integer	-2147483648 to 2147483647				0	RW	Num					

RW	Read / Write	RO	Read only	Num	Number parameter	Bit	Bit parameter	Txt	Text string	Bin	Binary parameter	FI	Filtered
ND	No default value	NC	Not copied	PT	Protected parameter	RA	Rating dependent	US	User save	PS	Power-down save	DE	Destination
IP	IP address	Mac	Mac address	Date	Date parameter	Time	Time parameter	SMP	Slot,menu,parameter	Chr	Character parameter	Ver	Version number

## 12.21 Menu 21: Second motor parameters

Parameter	Range(⌘)			Default(⇒)			Type					
	OL	RFC-A	RFC-S	OL	RFC-A	RFC-S						
21.001	M2 Maximum Reference Clamp	VM_POSITIVE_REF_CLAMP2 Hz	VM_POSITIVE_REF_CLAMP2 rpm	50 Hz: 50.0 60 Hz: 60.0	50 Hz: 1500.0 60 Hz: 1800.0	3000.0	RW	Num				US
21.002	M2 Minimum Reference Clamp	VM_NEGATIVE_REF_CLAMP2 Hz	VM_NEGATIVE_REF_CLAMP2 rpm	0.0			RW	Num				US
21.003	M2 Reference Selector	A1 A2 (0), A1 Preset (1), A2 Preset (2), Preset (3), Keypad (4), Precision (5), Keypad Ref (6)		A1 Preset (1)			RW	Txt				US
21.004	M2 Acceleration Rate 1	0.0 to VM_ACCEL_RATE s/100 Hz	0.000 to VM_ACCEL_RATE s/100 rpm	5.0 s	2.000 s	0.200 s	RW	Num				US
21.005	M2 Deceleration Rate 1	0.0 to VM_ACCEL_RATE s/100 Hz	0.000 to VM_ACCEL_RATE s/100 rpm	10.0 s	2.000 s	0.200 s	RW	Num				US
21.006	M2 Rated Frequency	0.0 to 550.0 Hz		50 Hz: 50.0 60 Hz: 60.0			RW	Num				US
21.007	M2 Rated Current	0.000 to VM_RATED_CURRENT A		Maximum Heavy Duty Rating (11.032)			RW	Num		RA		US
21.008	M2 Rated Speed	0 to 33000 rpm	0.00 to 33000.00 rpm	50 Hz: 1500 rpm 60 Hz: 1800 rpm	50 Hz: 1450.00 rpm 60 Hz: 1750.00 rpm	3000.00 rpm	RW	Num				US
21.009	M2 Rated Voltage	0 to VM_AC_VOLTAGE_SET V		200V drive: 230 V 400V drive 50Hz: 400 V 400V drive 60Hz: 460 V			RW	Num		RA		US
21.010	M2 Rated Power Factor	0.000 to 1.000		0.850			RW	Num		RA		US
21.011	M2 Number Of Motor Poles	Automatic (0) to 480 Poles (240)		Automatic (0)		6 Poles (3)	RW	Txt				US
21.012	M2 Stator Resistance	0.000000 to 1000.000000 Ω		0.000000 Ω			RW	Num		RA		US
21.014	M2 Transient Inductance / Ld	0.000 to 500.000 mH		0.000 mH			RW	Num		RA		US
21.015	Motor 2 Active	Off (0) or On (1)					RO	Bit	ND	NC	PT	
21.016	M2 Motor Thermal Time Constant 1	1.0 to 3000.0 s		89.0 s			RW	Num				US
21.017	M2 Speed Controller Proportional Gain Kp1	0.0000 to 200.0000 s/rad		0.0300 s/rad		0.0100 s/rad	RW	Num				US
21.018	M2 Speed Controller Integral Gain Ki1	0.00 to 655.35 s <sup>2</sup> /rad		0.10 s <sup>2</sup> /rad		1.00 s <sup>2</sup> /rad	RW	Num				US
21.019	M2 Speed Controller Differential Feedback Gain Kd1	0.00000 to 0.65535 1/rad		0.00000 1/rad			RW	Num				US
21.020	M2 Position Feedback Phase Angle	0.0 to 359.9°		0.0°			RW	Num	ND			US
21.021	M2 Motor Control Feedback Select	P1 Drive (0), P2 Drive (1), P1 Slot 1 (2), P2 Slot 1 (3), P1 Slot 2 (4), P2 Slot 2 (5)		P1 Drive (0)			RW	Txt				US
21.022	M2 Current Controller Kp Gain	0 to 30000		20		150	RW	Num				US
21.023	M2 Current Controller Ki Gain	0 to 30000		40		2000	RW	Num				US
21.024	M2 Stator Inductance	0.00 to 5000.00 mH		0.00 mH			RW	Num		RA		US
21.025	M2 Saturation Breakpoint 1	0.0 to 100.0 %		50.0 %			RW	Num				US
21.026	M2 Saturation Breakpoint 3	0.0 to 100.0 %		75.0 %			RW	Num				US
21.027	M2 Motoring Current Limit	0.0 to VM_MOTOR2_CURRENT_LIMIT %		165.0 %		250.0 %	RW	Num		RA		US
21.028	M2 Regenerating Current Limit	0.0 to VM_MOTOR2_CURRENT_LIMIT %		165.0 %		250.0 %	RW	Num		RA		US
21.029	M2 Symmetrical Current Limit	0.0 to VM_MOTOR2_CURRENT_LIMIT %		165.0 %		250.0 %	RW	Num		RA		US
21.030	M2 Volts Per 1000 rpm	0 to 10,000 V		98			RW	Num				US
21.032	M2 Current Reference Filter Time Constant 1	0.0 to 25.0 ms		0.0 ms			RW	Num				US
21.033	M2 Low Speed Thermal Protection Mode	0 to 1		0			RW	Num				US
21.034	M2 Current Controller Mode	Off (0) or On (1)		Off (0)			RW	Bit				US
21.035	M2 Notch Filter Centre Frequency	50 to 1000 Hz		100 Hz			RW	Num				US
21.036	M2 Notch Filter Bandwidth	0 to 500 Hz		0 Hz			RW	Num				US
21.039	M2 Motor Thermal Time Constant 2	1.0 to 3000.0 s		89.0 s			RW	Num				US
21.040	M2 Motor Thermal Time Constant 2 Scaling	0 to 100 %		0 %			RW	Num				US
21.041	M2 Saturation Breakpoint 2	0.0 to 100.0 %		0.0 %			RW	Num				US
21.042	M2 Saturation Breakpoint 4	0.0 to 100.0 %		0.0 %			RW	Num				US
21.043	M2 Torque Per Amp	0.00 to 500.00 Nm/A					RO	Num	ND	NC	PT	
	M2 Torque Per Amp			0.00 to 500.00 Nm/A		1.60 Nm/A	RW	Num				US
21.044	M2 No-load Core Loss	0.000 to 99999.999 kW		0.000 kW			RW	Num				US
21.045	M2 Rated Core Loss	0.000 to 99999.999 kW		0.000 kW			RW	Num				US
21.046	M2 Magnetising Current Limit	0.0 to 100.0 %				100.0 %	RW	Num				US
21.048	M2 No-load Lq	0.000 to 500.000 mH		0.000 mH			RW	Num		RA		US

RW	Read / Write	RO	Read only	Num	Number parameter	Bit	Bit parameter	Txt	Text string	Bin	Binary parameter	FI	Filtered
ND	No default value	NC	Not copied	PT	Protected parameter	RA	Rating dependent	US	User save	PS	Power-down save	DE	Destination

## 12.22 Menu 22: Additional Menu 0 set-up

Parameter	Range(⇅)			Default(⇒)			Type						
	OL	RFC-A	RFC-S	OL	RFC-A	RFC-S							
22.001	Parameter 00.001 Set-up	0.000 to 59.999			1.007			RW	Num			PT	US
22.002	Parameter 00.002 Set-up	0.000 to 59.999			1.006			RW	Num			PT	US
22.003	Parameter 00.003 Set-up	0.000 to 59.999			2.011			RW	Num			PT	US
22.004	Parameter 00.004 Set-up	0.000 to 59.999			2.021			RW	Num			PT	US
22.005	Parameter 00.005 Set-up	0.000 to 59.999			1.014			RW	Num			PT	US
22.006	Parameter 00.006 Set-up	0.000 to 59.999			4.007			RW	Num			PT	US
22.007	Parameter 00.007 Set-up	0.000 to 59.999			5.014	3.010		RW	Num			PT	US
22.008	Parameter 00.008 Set-up	0.000 to 59.999			5.015	3.011		RW	Num			PT	US
22.009	Parameter 00.009 Set-up	0.000 to 59.999			5.013	3.012		RW	Num			PT	US
22.010	Parameter 00.010 Set-up	0.000 to 59.999			5.004	3.002		RW	Num			PT	US
22.011	Parameter 00.011 Set-up	0.000 to 59.999			5.001		3.029	RW	Num			PT	US
22.012	Parameter 00.012 Set-up	0.000 to 59.999			4.001			RW	Num			PT	US
22.013	Parameter 00.013 Set-up	0.000 to 59.999			4.002			RW	Num			PT	US
22.014	Parameter 00.014 Set-up	0.000 to 59.999			4.011			RW	Num			PT	US
22.015	Parameter 00.015 Set-up	0.000 to 59.999			2.004			RW	Num			PT	US
22.016	Parameter 00.016 Set-up	0.000 to 59.999			0.000	2.002		RW	Num			PT	US
22.017	Parameter 00.017 Set-up	0.000 to 59.999			8.026	4.012		RW	Num			PT	US
22.018	Parameter 00.018 Set-up	0.000 to 59.999			3.123			RW	Num			PT	US
22.019	Parameter 00.019 Set-up	0.000 to 59.999			0.000			RW	Num			PT	US
22.020	Parameter 00.020 Set-up	0.000 to 59.999			0.000			RW	Num			PT	US
22.021	Parameter 00.021 Set-up	0.000 to 59.999			0.000			RW	Num			PT	US
22.022	Parameter 00.022 Set-up	0.000 to 59.999			1.010			RW	Num			PT	US
22.023	Parameter 00.023 Set-up	0.000 to 59.999			1.005			RW	Num			PT	US
22.024	Parameter 00.024 Set-up	0.000 to 59.999			1.021			RW	Num			PT	US
22.025	Parameter 00.025 Set-up	0.000 to 59.999			1.022			RW	Num			PT	US
22.026	Parameter 00.026 Set-up	0.000 to 59.999			1.023	3.008		RW	Num			PT	US
22.027	Parameter 00.027 Set-up	0.000 to 59.999			1.024	3.034		RW	Num			PT	US
22.028	Parameter 00.028 Set-up	0.000 to 59.999			6.013			RW	Num			PT	US
22.029	Parameter 00.029 Set-up	0.000 to 59.999			11.036			RW	Num			PT	US
22.030	Parameter 00.030 Set-up	0.000 to 59.999			11.042			RW	Num			PT	US
22.031	Parameter 00.031 Set-up	0.000 to 59.999			11.033			RW	Num			PT	US
22.032	Parameter 00.032 Set-up	0.000 to 59.999			11.032			RW	Num			PT	US
22.033	Parameter 00.033 Set-up	0.000 to 59.999			6.009	5.016	0.000	RW	Num			PT	US
22.034	Parameter 00.034 Set-up	0.000 to 59.999			11.030			RW	Num			PT	US
22.035	Parameter 00.035 Set-up	0.000 to 59.999			0.000			RW	Num			PT	US
22.036	Parameter 00.036 Set-up	0.000 to 59.999			0.000			RW	Num			PT	US
22.037	Parameter 00.037 Set-up	0.000 to 59.999			0.000			RW	Num			PT	US
22.038	Parameter 00.038 Set-up	0.000 to 59.999			4.013			RW	Num			PT	US
22.039	Parameter 00.039 Set-up	0.000 to 59.999			4.014			RW	Num			PT	US
22.040	Parameter 00.040 Set-up	0.000 to 59.999			5.012			RW	Num			PT	US
22.041	Parameter 00.041 Set-up	0.000 to 59.999			5.018			RW	Num			PT	US
22.042	Parameter 00.042 Set-up	0.000 to 59.999			5.011			RW	Num			PT	US
22.043	Parameter 00.043 Set-up	0.000 to 59.999			5.010		3.025	RW	Num			PT	US
22.044	Parameter 00.044 Set-up	0.000 to 59.999			5.009			RW	Num			PT	US
22.045	Parameter 00.045 Set-up	0.000 to 59.999			5.008			RW	Num			PT	US
22.046	Parameter 00.046 Set-up	0.000 to 59.999			5.007			RW	Num			PT	US
22.047	Parameter 00.047 Set-up	0.000 to 59.999			5.006		5.033	RW	Num			PT	US
22.048	Parameter 00.048 Set-up	0.000 to 59.999			11.031			RW	Num			PT	US
22.049	Parameter 00.049 Set-up	0.000 to 59.999			11.044			RW	Num			PT	US
22.050	Parameter 00.050 Set-up	0.000 to 59.999			11.029			RW	Num			PT	US
22.051	Parameter 00.051 Set-up	0.000 to 59.999			10.037			RW	Num			PT	US
22.052	Parameter 00.052 Set-up	0.000 to 59.999			0.000			RW	Num			PT	US
22.053	Parameter 00.053 Set-up	0.000 to 59.999			4.015			RW	Num			PT	US
22.054	Parameter 00.054 Set-up	0.000 to 59.999			0.000			RW	Num			PT	US
22.055	Parameter 00.055 Set-up	0.000 to 59.999			0.000			RW	Num			PT	US
22.056	Parameter 00.056 Set-up	0.000 to 59.999			0.000			RW	Num			PT	US
22.057	Parameter 00.057 Set-up	0.000 to 59.999			0.000			RW	Num			PT	US

Parameter	Range(⇅)	Default(⇄)			Type							
		OL	RFC-A	RFC-S								
22.058	Parameter 00.058 Set-up	0.000 to 59.999			0.000		RW	Num			PT	US
22.059	Parameter 00.059 Set-up	0.000 to 59.999			0.000		RW	Num			PT	US
22.060	Parameter 00.060 Set-up	0.000 to 59.999			0.000		RW	Num			PT	US
22.061	Parameter 00.061 Set-up	0.000 to 59.999			0.000		RW	Num			PT	US
22.062	Parameter 00.062 Set-up	0.000 to 59.999			0.000		RW	Num			PT	US
22.063	Parameter 00.063 Set-up	0.000 to 59.999			0.000		RW	Num			PT	US
22.064	Parameter 00.064 Set-up	0.000 to 59.999			0.000		RW	Num			PT	US
22.065	Parameter 00.065 Set-up	0.000 to 59.999			0.000		RW	Num			PT	US
22.066	Parameter 00.066 Set-up	0.000 to 59.999			0.000		RW	Num			PT	US
22.067	Parameter 00.067 Set-up	0.000 to 59.999			0.000		RW	Num			PT	US
22.068	Parameter 00.068 Set-up	0.000 to 59.999			0.000		RW	Num			PT	US
22.069	Parameter 00.069 Set-up	0.000 to 59.999			0.000		RW	Num			PT	US
22.070	Parameter 00.070 Set-up	0.000 to 59.999			0.000		RW	Num			PT	US
22.071	Parameter 00.071 Set-up	0.000 to 59.999			0.000		RW	Num			PT	US
22.072	Parameter 00.072 Set-up	0.000 to 59.999			0.000		RW	Num			PT	US
22.073	Parameter 00.073 Set-up	0.000 to 59.999			0.000		RW	Num			PT	US
22.074	Parameter 00.074 Set-up	0.000 to 59.999			0.000		RW	Num			PT	US
22.075	Parameter 00.075 Set-up	0.000 to 59.999			0.000		RW	Num			PT	US
22.076	Parameter 00.076 Set-up	0.000 to 59.999			0.000		RW	Num			PT	US
22.077	Parameter 00.077 Set-up	0.000 to 59.999			0.000		RW	Num			PT	US
22.078	Parameter 00.078 Set-up	0.000 to 59.999			0.000		RW	Num			PT	US
22.079	Parameter 00.079 Set-up	0.000 to 59.999			0.000		RW	Num			PT	US
22.080	Parameter 00.080 Set-up	0.000 to 59.999			0.000		RW	Num			PT	US

RW	Read / Write	RO	Read only	Num	Number parameter	Bit	Bit parameter	Txt	Text string	Bin	Binary parameter	FI	Filtered
ND	No default value	NC	Not copied	PT	Protected parameter	RA	Rating dependent	US	User save	PS	Power-down save	DE	Destination

## 12.23 Slot 3 Menu 0: Ethernet set-up

Parameter	Range(⇅)	Default(⇄)			Type							
		OL	RFC-A / S	RFC-S								
3.00.001	Module ID	0 to 65535					RO	Num	ND	NC	PT	
3.00.002	Software Version	0 to 99999999					RO	Num	ND	NC	PT	
3.00.003	Hardware version	0.00 to 99.99					RO	Num	ND	NC	PT	
3.00.004	Serial Number LS	00000000 to 99999999					RO	Num	ND	NC	PT	
3.00.005	Serial Number MS	0 to 99999999					RO	Num	ND	NC	PT	
3.00.006	Status	Bootldr - Update (-2), Bootldr - Idle (-1), Initialising (0), OK (1), Config (2), Error (3)					RO	Txt	ND	NC	PT	
3.00.007	Reset	Off (0) or On (1)			Off (0)		RW	Bit			NC	
3.00.008	Default	Off (0) or On (1)			Off (0)		RW	Bit			NC	
3.00.009	Active Alarm Bits	0000000000000000 to 1111111111111111			0000000000000000		RO	Bin			NC	
3.00.010	Active IP Address	0 to 255			0.0.0.0		RO	IP			NC	PT

RW	Read / Write	RO	Read only	Num	Number parameter	Bit	Bit parameter	Txt	Text string	Bin	Binary parameter	FI	Filtered
ND	No default value	NC	Not copied	PT	Protected parameter	RA	Rating dependent	US	User save	PS	Power-down save	DE	Destination

## 12.24 Slot 3 Menu 2: Ethernet configuration

Parameter	Range(Φ)		Default(⇒)			Type							
	OL	RFC-A / S	OL	RFC-A	RFC-S								
3.02.003	Network Status	Initialising (0), Links Down (1), DHCP In Progress (2), No Address (3), Ready (4), Active (5)					RO	Txt	ND	NC	PT		
3.02.004	Network Message Count	0 to 65535 Messages/s					RO	Bit					US
3.02.005	DHCP Enable	Off (0) or On (1)		On (1)			RW	Num	ND	NC	PT		
3.02.006	IP Address	0.0.0.0 to 255.255.255.255		192.168.1.100			RO	Num	ND	NC	PT		
3.02.007	Subnet Mask	0.0.0.0 to 255.255.255.255		255.255.255.0			RO	Num	ND	NC	PT		
3.02.008	Default Gateway	0.0.0.0 to 255.255.255.255		192.168.1.254			RO	Txt	ND	NC	PT		
3.02.009	Primary DNS	0.0.0.0 to 255.255.255.255		0.0.0.0			RO	Bin		NC			
3.02.010	Secondary DNS	0.0.0.0 to 255.255.255.255		0.0.0.0			RO	IP		NC	PT		
3.02.011	MAC Address	00:00:00:00:00:00 to FF:FF:FF:FF:FF:FF					RO	Mac	ND	NC	PT		
3.02.018	Protocol Mode Select	Ethernet/IP (1), PROFINET (2)		Ethernet/IP (1)			RW	Txt					US
3.02.019	Active Protocol Mode	Ethernet/IP (1), PROFINET (2)		Ethernet/IP (1)			RO	Txt		NC	PT		
3.02.020	Priority Protocol	None (0), Modbus TCP (1), EtherNet/IP (2)		None (0)			RW	Txt					US
3.02.021	Web Server Enable	Off (0) or On (1)		On (1)			RW	Bit					US
3.02.022	Web Server Port	0 to 65535		80			RW	Num					US
3.02.024	Ethernet MTU	158 to 1500 Bytes		1500 Bytes			RW	Num					US
3.02.025	Gateway Mode	Switch (0), Gateway (1), Strict Gateway (2)		Switch (0)			RW	Txt					US
3.02.030	VLAN Enable	Off (0) or On (1)		Off (0)			RW	Bit					US
3.02.034	Drive compatibility mode	Unidrive M (0), Unidrive SP (1)		Unidrive M (0)			RW	Txt					US
3.02.035	Non cyclic enable	Off (0) or On (1)		Off (0)			RW	Bit					US
3.02.036	Non cyclic base parameter	0 to 59999		0			RW	Num					US

RW	Read / Write	RO	Read only	Num	Number parameter	Bit	Bit parameter	Txt	Text string	Bin	Binary parameter	FI	Filtered
ND	No default value	NC	Not copied	PT	Protected parameter	RA	Rating dependent	US	User save	PS	Power-down save	DE	Destination

## 12.25 Slot 3 Menu 9: Resources

Parameter	Range(Φ)		Default(⇒)			Type							
	OL	RFC-A / S	OL	RFC-A	RFC-S								
3.09.001	Cyclic tx links free	0 to 255					RO	Num	ND	NC	PT		
3.09.002	Cyclic rx links free	0 to 255					RO	Num	ND	NC	PT		
3.09.003	Fieldbus Links Free	0 to 255					RO	Num	ND	NC	PT		
3.09.004	Cyclic Mappings Free	0 to 255					RO	Num	ND	NC	PT		
3.09.008	Background cycles per second	0 to 65535					RO	Num	ND	NC	PT		
3.09.010	Synchronous Task % Free	0 to 255 %					RO	Num	ND	NC	PT		
3.09.011	Nonsync link update period	0.00 to 655.35					RO	Num	ND	NC	PT		
3.09.020	Synchronous Task Worst % Free	0 to 255 %					RO	Num	ND	NC	PT		
3.09.021	Max nonsync link update period	0.00 to 655.35					RO	Num	ND	NC	PT		
3.09.030	PCB Temperature	-128 to 127 °C					RO	Num	ND	NC	PT		

RW	Read / Write	RO	Read only	Num	Number parameter	Bit	Bit parameter	Txt	Text string	Bin	Binary parameter	FI	Filtered
ND	No default value	NC	Not copied	PT	Protected parameter	RA	Rating dependent	US	User save	PS	Power-down save	DE	Destination

## 12.26 Slot 3 Menu 10: Easy Mode

Parameter	Range(φ)		Default(⇒)			Type						
	OL	RFC-A / S	OL	RFC-A	RFC-S							
3.10.001	Enable	Off (0) or On (1)	On (1)			RW	Bit					US
3.10.002	Reset	Off (0) or On (1)	Off (0)			RW	Bit		NC			
3.10.003	Default	Off (0) or On (1)	Off (0)			RW	Bit		NC			
3.10.004	Cyclic Messages Per Second	0 to 65535 Messages/s				RO	Num	ND	NC	PT		
3.10.005	Configuration Valid	Off (0) or On (1)				RO	Bit	ND	NC	PT		
3.10.006	Operational	Off (0) or On (1)				RO	Bit	ND	NC	PT		
3.10.007	Active Configuration	None (0), Easy Mode (1), Offline (2)				RO	Txt					US
3.10.008	Timeout Count	0 to 65535				RO	Num	ND	NC	PT		
3.10.009	Data Late Count	0 to 65535				RO	Num	ND	NC	PT		
3.10.010	Tx1 Link profile	Std (0), Sync (1)	Std (0)			RW	Txt					US
3.10.011	Tx1 Link number	0 to 255	0			RO	Num					US
3.10.012	Tx1 Source parameter	0 to 499999	0			RW	Num			PT		US
3.10.013	Tx1 Parameter count	0 to 10	0			RW	Num					US
3.10.014	Tx1 Link transmission type	Unicast (0), Broadcast (1), Multicast1 (2), Multicast2 (3), Multicast3 (4), Multicast4 (5), Multicast5 (6), Multicast6 (7), Multicast7 (8), Multicast8 (9), Multicast9 (10), Multicast10 (11)	Unicast (0)			RW	Txt					US
3.10.015	Tx1 Destination address	0.0.0.0 to 255.255.255.255	0.0.0.0			RW	IP					US
3.10.016	Tx1 Message Rate	0 to 100 ms	0 ms			RW	Num					US
3.10.019	Tx1 Link status	Disabled (-31), VLAN disabled (-30), Reserved 29 (-29), Reserved 28 (-28), Reserved 27 (-27), Reserved 26 (-26), Reserved 25 (-25), Reserved 24 (-24), Reserved 23 (-23), Invalid DST IP (-22), SYNC unsupported (-21), MEC offset (-20), Invalid tx rate (-19), Too many mapping (-18), Link busy (-17), Invalid profile (-16), Invalid mapping (-15), Read only param (-14), Msg mismatch (-13), Msg too long (-12), Attrib NA (-11), Attrib RO (-10), Attrib missing (-9), Timeout (-8), In error (-7), Link num in use (-6), Not editable (-5), Invalid link num (-4), Invalid args (-3), Too many links (-2), Out of memory (-1), OK (0), Not running (1), OK sync (2)				RO	Txt	ND	NC	PT		
3.10.020	Tx2 Link profile	Std (0), Sync (1)	Std (0)			RW	Txt					US
3.10.021	Tx2 Link number	0 to 255	0			RW	Num					US
3.10.022	Tx2 Source parameter	0 to 499999	0			RW	Num			PT		US
3.10.023	Tx2 Parameter count	0 to 10	0			RW	Num					US
3.10.024	Tx2 Link transmission type	Unicast (0), Broadcast (1), Multicast1 (2), Multicast2 (3), Multicast3 (4), Multicast4 (5), Multicast5 (6), Multicast6 (7), Multicast7 (8), Multicast8 (9), Multicast9 (10), Multicast10 (11)	Unicast (0)			RW	Txt					US
3.10.025	Tx2 Destination address	0.0.0.0 to 255.255.255.255	0.0.0.0			RW	IP					US
3.10.026	Tx1 Message Rate	0 to 100 ms	0 ms			RW	Num					US
3.10.029	Tx2 Link status	Disabled (-31), VLAN disabled (-30), Reserved 29 (-29), Reserved 28 (-28), Reserved 27 (-27), Reserved 26 (-26), Reserved 25 (-25), Reserved 24 (-24), Reserved 23 (-23), Invalid DST IP (-22), SYNC unsupported (-21), MEC offset (-20), Invalid tx rate (-19), Too many mapping (-18), Link busy (-17), Invalid profile (-16), Invalid mapping (-15), Read only param (-14), Msg mismatch (-13), Msg too long (-12), Attrib NA (-11), Attrib RO (-10), Attrib missing (-9), Timeout (-8), In error (-7), Link num in use (-6), Not editable (-5), Invalid link num (-4), Invalid args (-3), Too many links (-2), Out of memory (-1), OK (0), Not running (1), OK sync (2)				RO	Txt	ND	NC	PT		
3.10.030	Tx3 Link profile	Std (0), Sync (1)	Std (0)			RW	Txt					US
3.10.031	Tx3 Link number	0 to 255	0			RW	Num					US
3.10.032	Tx3 Source parameter	0 to 499999	0			RW	Num			PT		US
3.10.033	Tx3 Parameter count	0 to 10	0			RW	Num					US
3.10.034	Tx3 Link transmission type	Unicast (0), Broadcast (1), Multicast1 (2), Multicast2 (3), Multicast3 (4), Multicast4 (5), Multicast5 (6), Multicast6 (7), Multicast7 (8), Multicast8 (9), Multicast9 (10), Multicast10 (11)	Unicast (0)			RW	Txt					US
3.10.035	Tx3 Destination address	0.0.0.0 to 255.255.255.255	0.0.0.0			RW	IP					US
3.10.036	Tx3 Message Rate	0 to 100 ms	0 ms			RW	Num					US
3.10.039	Tx3 Link status	Disabled (-31), VLAN disabled (-30), Reserved 29 (-29), Reserved 28 (-28), Reserved 27 (-27), Reserved 26 (-26), Reserved 25 (-25), Reserved 24 (-24), Reserved 23 (-23), Invalid DST IP (-22), SYNC unsupported (-21), MEC offset (-20), Invalid tx rate (-19), Too many mapping (-18), Link busy (-17), Invalid profile (-16), Invalid mapping (-15), Read only param (-14), Msg mismatch (-13), Msg too long (-12), Attrib NA (-11), Attrib RO (-10), Attrib missing (-9), Timeout (-8), In error (-7), Link num in use (-6), Not editable (-5), Invalid link num (-4), Invalid args (-3), Too many links (-2), Out of memory (-1), OK (0), Not running (1), OK sync (2)				RO	Txt	ND	NC	PT		
3.10.040	Rx1 Link profile	Std (0), Sync (1)	Std (0)			RW	Txt					US
3.10.041	Rx1 Link number	0 to 255	0			RW	Num					US
3.10.042	Rx1 Destination parameter	0 to 499999	0			RW	Num					US
3.10.043	Rx1 Parameter count	0 to 10	0			RW	Num					US
3.10.044	Rx1 Source type	Direct (0), Multicast1 (1), Multicast2 (2), Multicast3 (3), Multicast4 (4), Local (5), Multicast5 (6), Multicast6 (7), Multicast7 (8), Multicast8 (9), Multicast9 (10), Multicast10 (11)	Direct (0)			RW	Txt					US

Safety information	Product information	Mechanical installation	Electrical installation	Getting started	Basic parameters	Running the motor	Optimization	Drive communication	SD Card Operation	Onboard PLC	<b>Advanced parameters</b>	Diagnostics	UL listing information
--------------------	---------------------	-------------------------	-------------------------	-----------------	------------------	-------------------	--------------	---------------------	-------------------	-------------	----------------------------	-------------	------------------------

Parameter		Range(⊕)		Default(⇒)			Type						
		OL	RFC-A / S	OL	RFC-A	RFC-S							
3.10.045	Rx1 Timeout	0 to 65535 ms		100 ms			RW	Num					US
3.10.046	Rx1 Timeout action	Trip (0), Clear output (1), Hold last (2)		Trip (0)			RW	Txt					US
3.10.047	Rx1 Timeout event destination	This slot (0), Slot 1 (1), Slot 2 (2), Slot 3 (3),		This slot (0)			RW	Txt					US
3.10.048	Rx1 Timeout event type	No Event (0), Event (1), Event1 (2), Event2 (3), Event3 (4)		No Event (0)			RW	Txt					US
3.10.049	Rx1 Link status	Disabled (-31), VLAN disabled (-30), Reserved 29 (-29), Reserved 28 (-28), Reserved 27 (-27), Reserved 26 (-26), Reserved 25 (-25), Reserved 24 (-24), Reserved 23 (-23), Invalid DST IP (-22), SYNC unsupported (-21), MEC offset (-20), Invalid tx rate (-19), Too many mapping (-18), Link busy (-17), Invalid profile (-16), Invalid mapping (-15), Read only param (-14), Msg mismatch (-13), Msg too long (-12), Attrib NA (-11), Attrib RO (-10), Attrib missing (-9), Timeout (-8), In error (-7), Link num in use (-6), Not editable (-5), Invalid link num (-4), Invalid args (-3), Too many links (-2), Out of memory (-1), OK (0), Not running (1), OK sync (2)					RO	Txt	ND	NC	PT		
3.10.050	Rx2 Link profile	Std (0), Sync (1)		Std (0)			RW	Txt					US
3.10.051	Rx2 Link number	0 to 255		0			RW	Num					US
3.10.052	Rx2 Destination parameter	0 to 499999		0			RW	Num					US
3.10.053	Rx2 Parameter count	0 to 10		0			RW	Num					US
3.10.054	Rx2 Source type	Direct (0), Multicast1 (1), Multicast2 (2), Multicast3 (3), Multicast4 (4), Local (5), Multicast5 (6), Multicast6 (7), Multicast7 (8), Multicast8 (9), Multicast9 (10), Multicast10 (11)		Direct (0)			RW	Txt					US
3.10.055	Rx2 Timeout	0 to 65535 ms		100 ms			RW	Num					US
3.10.056	Rx2 Timeout action	Trip (0), Clear output (1), Hold last (2)		Trip (0)			RW	Txt					US
3.10.057	Rx2 Timeout event destination	This slot (0), Slot 1 (1), Slot 2 (2), Slot 3 (3),		This slot (0)			RW	Txt					US
3.10.058	Rx2 Timeout event type	No Event (0), Event (1), Event1 (2), Event2 (3), Event3 (4)		No Event (0)			RW	Txt					US
3.10.059	Rx2 Link status	Disabled (-31), VLAN disabled (-30), Reserved 29 (-29), Reserved 28 (-28), Reserved 27 (-27), Reserved 26 (-26), Reserved 25 (-25), Reserved 24 (-24), Reserved 23 (-23), Invalid DST IP (-22), SYNC unsupported (-21), MEC offset (-20), Invalid tx rate (-19), Too many mapping (-18), Link busy (-17), Invalid profile (-16), Invalid mapping (-15), Read only param (-14), Msg mismatch (-13), Msg too long (-12), Attrib NA (-11), Attrib RO (-10), Attrib missing (-9), Timeout (-8), In error (-7), Link num in use (-6), Not editable (-5), Invalid link num (-4), Invalid args (-3), Too many links (-2), Out of memory (-1), OK (0), Not running (1), OK sync (2)					RO	Txt	ND	NC	PT		
3.10.060	Rx3 Link profile	Std (0), Sync (1)		Std (0)			RW	Txt					US
3.10.061	Rx3 Link number	0 to 255		0			RW	Num					US
3.10.062	Rx3 Destination parameter	0 to 499999		0			RW	Num					US
3.10.063	Rx3 Parameter count	0 to 10		0			RW	Num					US
3.10.064	Rx3 Source type	Direct (0), Multicast1 (1), Multicast2 (2), Multicast3 (3), Multicast4 (4), Local (5), Multicast5 (6), Multicast6 (7), Multicast7 (8), Multicast8 (9), Multicast9 (10), Multicast10 (11)		Direct (0)			RW	Txt					US
3.10.065	Rx3 Timeout	0 to 65535 ms		100 ms			RW	Num					US
3.10.066	Rx3 Timeout action	Trip (0), Clear output (1), Hold last (2)		Trip (0)			RW	Txt					US
3.10.067	Rx3 Timeout event destination	This slot (0), Slot 1 (1), Slot 2 (2), Slot 3 (3),		This slot (0)			RW	Txt					US
3.10.068	Rx3 Timeout event type	No Event (0), Event (1), Event1 (2), Event2 (3), Event3 (4)		No Event (0)			RW	Txt					US
3.10.069	Rx3 Link status	Disabled (-31), VLAN disabled (-30), Reserved 29 (-29), Reserved 28 (-28), Reserved 27 (-27), Reserved 26 (-26), Reserved 25 (-25), Reserved 24 (-24), Reserved 23 (-23), Invalid DST IP (-22), SYNC unsupported (-21), MEC offset (-20), Invalid tx rate (-19), Too many mapping (-18), Link busy (-17), Invalid profile (-16), Invalid mapping (-15), Read only param (-14), Msg mismatch (-13), Msg too long (-12), Attrib NA (-11), Attrib RO (-10), Attrib missing (-9), Timeout (-8), In error (-7), Link num in use (-6), Not editable (-5), Invalid link num (-4), Invalid args (-3), Too many links (-2), Out of memory (-1), OK (0), Not running (1), OK sync (2)					RO	Txt	ND	NC	PT		

RW	Read / Write	RO	Read only	Num	Number parameter	Bit	Bit parameter	Txt	Text string	Bin	Binary parameter	FI	Filtered
ND	No default value	NC	Not copied	PT	Protected parameter	RA	Rating dependent	US	User save	PS	Power-down save	DE	Destination
IP	IP address	Mac	Mac address	Date	Date parameter	Time	Time parameter	SMP	Slot,menu,parameter	Chr	Character parameter	Ver	Version number

## 12.27 Slot 3 Menu 11: Synchronization

Parameter	Range(φ)		Default(⇒)			Type						
	OL	RFC-A / S	OL	RFC-A	RFC-S							
3.11.001 Preferred Sync Master	0 to 4		1			RW	Num					US
3.11.002 Master Clock Domain	0 to 3		0			RW	Num					US
3.11.005 Grandmaster MAC Address	00:00:00:00:00:00 to FF:FF:FF:FF:FF:FF					RO	Mac	ND	NC	PT		
3.11.006 Synchronisation Jitter From Grandmaster	-2147483648 to 2147483647 ns					RO	Num	ND	NC	PT		
3.11.007 Synchronisation Jitter Threshold	500 to 1000000 ns		1000 ns			RW	Num					US
3.11.008 Module Synchronised Flag	Off (0) or On (1)		Off (0)			RO	Bit					
3.11.009 Inhibit Drive Synchronisation	Off (0) or On (1)		Off (0)			RW	Bit					US
3.11.010 PTP Date	00-00-00 to 31-12-99					RO	Date	ND	NC	PT		
3.11.011 PTP Time	00:00:00 to 23:59:59					RO	Time	ND	NC	PT		
3.11.015 PTP Delay Measurement Select	P2P DELAY (1), OFF (2)		P2P DELAY (1)			RW	Txt					US
3.11.016 PTP Sync Rate	-4 to 0		-4			RW	Num					US
3.11.017 In sync window length	3 to 255 s		20 s			RW	Num					US
3.11.020 Network Error Count	0 to 4294967295					RO	Num	ND	NC	PT		
3.11.022 Interoption Sync Status	MASTER (0), PRODUCER (1), INDEPENDENT (2)					RO	Txt	ND	NC	PT		
3.11.030 Easy Mode Maximum Network Delay	1 to 100 ms		3 ms			RW	Num					US
3.11.040 Rx1 Late Synchronisation Frame Action	Trip (1), Do not use (2), Use (3)		Trip (1)			RW	Txt					US
3.11.041 Rx1 Late Synchronisation Frame Destination	This slot (0), Slot 1 (1), Slot 2 (2), Slot 3 (3)		This slot (0)			RW	Txt					US
3.11.042 Rx1 Late Synchronisation Frame Event	No Event (0), Event (1), Event1 (2), Event2 (3), Event3 (4)		No Event (0)			RW	Txt					US
3.11.050 Rx2 Late Synchronisation Frame Action	Trip (1), Do not use (2), Use (3)		Trip (1)			RW	Txt					US
3.11.051 Rx2 Late Synchronisation Frame Destination	This slot (0), Slot 1 (1), Slot 2 (2), Slot 3 (3)		This slot (0)			RW	Txt					US
3.11.052 Rx2 Late Synchronisation Frame Event	No Event (0), Event (1), Event1 (2), Event2 (3), Event3 (4)		No Event (0)			RW	Txt					US
3.11.060 Rx3 Late Synchronisation Frame Action	Trip (1), Do not use (2), Use (3)		Trip (1)			RW	Txt					US
3.11.061 Rx3 Late Synchronisation Frame Destination	This slot (0), Slot 1 (1), Slot 2 (2), Slot 3 (3)		This slot (0)			RW	Txt					US
3.11.062 Rx3 Late Synchronisation Frame Event	No Event (0), Event (1), Event1 (2), Event2 (3), Event3 (4)		No Event (0)			RW	Txt					US

RW	Read / Write	RO	Read only	Num	Number parameter	Bit	Bit parameter	Txt	Text string	Bin	Binary parameter	FI	Filtered
ND	No default value	NC	Not copied	PT	Protected parameter	RA	Rating dependent	US	User save	PS	Power-down save	DE	Destination
IP	IP address	Mac	Mac address	Date	Date parameter	Time	Time parameter	SMP	Slot,menu,parameter	Chr	Character parameter	Ver	Version number

## 12.28 Slot 3 Menu 15: Modbus

Parameter	Range(φ)		Default(⇒)			Type						
	OL	RFC-A / S	OL	RFC-A	RFC-S							
3.15.001 Enable	Off (0) or On (1)		On (1)			RW	Bit					US
3.15.002 Reset	Off (0) or On (1)		Off (0)			RW	Bit			NC		
3.15.003 Default	Off (0) or On (1)		Off (0)			RW	Bit			NC		
3.15.004 Modbus Configuration Error	No error (0), Port in use (1), Timeout event (2), Num Connections (3)					RO	Txt	ND	NC	PT		
3.15.005 Modbus Listening Port	0 to 65535		502			RW	Num					US
3.15.006 Maximum Connections	0 to 10		2			RW	Num					US
3.15.007 Maximum Priority Connections	0 to 5		0			RW	Num					US
3.15.008 Maximum Connections Per Client	1 to 4		2			RW	Num					US
3.15.009 Modbus Timeout	1 to 10000 ms		100 ms			RW	Num					US
3.15.010 Modbus Timeout Action	Trip (0), No action (1)		No action (1)			RW	Txt					US
3.15.011 Modbus Timeout Event Destination	This slot (0), Slot 1 (1), Slot 2 (2), Slot 3 (3), Slot 4 (4)		This slot (0)			RW	Txt					US
3.15.012 Modbus Timeout Event Type	No event (0), Trigger Event (1), Trigger Event 1 (2), Trigger Event 2 (3), Trigger Event 3 (4), Trigger Event 4 (5)		No event (0)			RW	Txt					US
3.15.013 Modbus Register Addressing Mode	Standard (0), Modified (1)		Standard (0)			RW	Txt					US
3.15.020 Priority Connection 1	0.0.0.0 to 255.255.255.255		0.0.0.0			RW	IP					US
3.15.021 Priority Connection 2	0.0.0.0 to 255.255.255.255		0.0.0.0			RW	IP					US
3.15.022 Priority Connection 3	0.0.0.0 to 255.255.255.255		0.0.0.0			RW	IP					US
3.15.023 Priority Connection 4	0.0.0.0 to 255.255.255.255		0.0.0.0			RW	IP					US

RW	Read / Write	RO	Read only	Num	Number parameter	Bit	Bit parameter	Txt	Text string	Bin	Binary parameter	FI	Filtered
ND	No default value	NC	Not copied	PT	Protected parameter	RA	Rating dependent	US	User save	PS	Power-down save	DE	Destination
IP	IP address	Mac	Mac address	Date	Date parameter	Time	Time parameter	SMP	Slot,menu,parameter	Chr	Character parameter	Ver	Version number

## 12.29 Slot 3 Menu 20: EtherNet/IP

Parameter	Range(⌘)		Default(⇒)			Type						
	OL	RFC-A / S	OL	RFC-A	RFC-S							
3.20.001	Enable EtherNet/IP	Off (0) or On (1)	On (1)			RW	Bit					US
3.20.002	Reset	Off (0) or On (1)	Off (0)			RW	Bit		NC			
3.20.003	Default	Off (0) or On (1)	Off (0)			RW	Bit		NC			
3.20.004	Configuration error	No error (0), RPI event dst (1), RPI event type (2), IDLE event dst (3), IDLE event type (4), Input mapping (5), Output mapping (6), In cons trig pr (7), Out cons trig pr (8)				RO	Txt	ND	NC	PT		
3.20.007	Cyclic data transfers per second	0 to 65535 Messages/s				RO	Num	ND	NC	PT		
3.20.011	RPI timeout action	Trip (0), Send fit values (1), Clear output (2), Hold last (3), No Action (4)	Hold last (3)			RW	Txt					US
3.20.012	RPI timeout event destination	This slot (0), Slot 1 (1), Slot 2 (2), Slot 3 (3), Slot 4 (4)	This slot (0)			RW	Txt					US
3.20.013	RPI timeout event type	No event (0), Trigger Event (1), Trigger Event 1 (2), Trigger Event 2 (3), Trigger Event 3 (4), Trigger Event 4 (5)	No event (0)			RW	Txt					US
3.20.015	PLC idle action	Trip (0), Send fit values (1), Clear output (2), Hold last (3), No Action (4)	No Action (4)			RW	Txt					US
3.20.016	PLC idle event destination	This slot (0), Slot 1 (1), Slot 2 (2), Slot 3 (3), Slot 4 (4)	This slot (0)			RW	Txt					US
3.20.017	PLC idle event type	No event (0), Trigger Event (1), Trigger Event 1 (2), Trigger Event 2 (3), Trigger Event 3 (4), Trigger Event 4 (5)	No event (0)			RW	Txt					US
3.20.018	Active input assembly object	100-PrimaryI (0), 70-BscSpdCtrlI (1), 71-ExtSpdCtrlI (2), 72-SpdTqCtrlI (3), 73-ExtSpdTqCtrlI (4)				RO	Txt	ND	NC	PT		
3.20.019	Active output assembly object	101-PrimaryO (0), 20-BscSpdCtrlO (1), 21-ExtSpdCtrlO (2), 22-SpdTqCtrlO (3), 23-ExtSpdTqCtrlO (4)				RO	Txt	ND	NC	PT		
3.20.020	Input assembly object size	4 to 128 Bytes	8 Bytes			RW	Num					US
3.20.021	Output assembly object size	4 to 128 Bytes	8 Bytes			RW	Num					US
3.20.024	Input assembly object process time	0 to 65535 ms				RO	Num	ND	NC	PT		
3.20.025	Output assembly object process time	0 to 65535 ms				RO	Num	ND	NC	PT		
3.20.026	Input assembly object consistency enable	Off (0) or On (1)	Off (0)			RW	Bit					US
3.20.027	Input assembly object consistency trigger parameter	0 to 499999	0			RW	Num					US
3.20.028	Output assembly object consistency enable	Off (0) or On (1)	Off (0)			RW	Bit					US
3.20.029	Output assembly object consistency trigger parameter	0 to 499999	0			RW	Num					US
3.20.030	Custom Vendor ID	257 - CT (0), 553 - CT AMERICA (1)	257 - CT (0)			RW	Txt					US
3.20.031	Custom product code	0 to 65535	0			RW	Num					US
3.20.032	Custom product revision code	0 to 65535	0			RW	Num					US
3.20.033	Actual Product Code	0 to 65535				RO	Num	ND	NC	PT		
3.20.034	Actual Product Revision	0 to 65535				RO	Num	ND	NC	PT		
3.20.040	Type of Motor 1	2-FC DC (0), 6-WRI (1), 7-SCI (2), 9-Sin PM BL (3), 10-Trap PM BL (4)	7-SCI (2)			RO	Txt				PT	US
3.20.041	Type of Motor 2	2-FC DC (0), 6-WRI (1), 7-SCI (2), 9-Sin PM BL (3), 10-Trap PM BL (4)	7-SCI (2)			RO	Txt				PT	US

RW	Read / Write	RO	Read only	Num	Number parameter	Bit	Bit parameter	Txt	Text string	Bin	Binary parameter	FI	Filtered
ND	No default value	NC	Not copied	PT	Protected parameter	RA	Rating dependent	US	User save	PS	Power-down save	DE	Destination

## 12.30 Slot 3 Menu 21: EtherNet/IP In Mappings

Parameter		Range(†)		Default(⇒)			Type								
		OL	RFC-A / S	OL	RFC-A	RFC-S									
3.21.001	Input mapping parameter 1					10040				RW	Num			PT	US
3.21.002	Input mapping parameter 2					2001				RW	Num			PT	US
3.21.003	Input mapping parameter 3					0				RW	Num			PT	US
3.21.004	Input mapping parameter 4					0				RW	Num			PT	US
3.21.005	Input mapping parameter 5					0				RW	Num			PT	US
3.21.006	Input mapping parameter 6					0				RW	Num			PT	US
3.21.007	Input mapping parameter 7					0				RW	Num			PT	US
3.21.008	Input mapping parameter 8					0				RW	Num			PT	US
3.21.009	Input mapping parameter 9					0				RW	Num			PT	US
3.21.010	Input mapping parameter 10					0				RW	Num			PT	US
3.21.011	Input mapping parameter 11					0				RW	Num			PT	US
3.21.012	Input mapping parameter 12					0				RW	Num			PT	US
3.21.013	Input mapping parameter 13					0				RW	Num			PT	US
3.21.014	Input mapping parameter 14					0				RW	Num			PT	US
3.21.015	Input mapping parameter 15					0				RW	Num			PT	US
3.21.016	Input mapping parameter 16		0 to 499999			0				RW	Num			PT	US
3.21.017	Input mapping parameter 17					0				RW	Num			PT	US
3.21.018	Input mapping parameter 18					0				RW	Num			PT	US
3.21.019	Input mapping parameter 19					0				RW	Num			PT	US
3.21.020	Input mapping parameter 20					0				RW	Num			PT	US
3.21.021	Input mapping parameter 21					0				RW	Num			PT	US
3.21.022	Input mapping parameter 22					0				RW	Num			PT	US
3.21.023	Input mapping parameter 23					0				RW	Num			PT	US
3.21.024	Input mapping parameter 24					0				RW	Num			PT	US
3.21.025	Input mapping parameter 25					0				RW	Num			PT	US
3.21.026	Input mapping parameter 26					0				RW	Num			PT	US
3.21.027	Input mapping parameter 27					0				RW	Num			PT	US
3.21.028	Input mapping parameter 28					0				RW	Num			PT	US
3.21.029	Input mapping parameter 29					0				RW	Num			PT	US
3.21.030	Input mapping parameter 30					0				RW	Num			PT	US

RW	Read / Write	RO	Read only	Num	Number parameter	Bit	Bit parameter	Txt	Text string	Bin	Binary parameter	FI	Filtered
ND	No default value	NC	Not copied	PT	Protected parameter	RA	Rating dependent	US	User save	PS	Power-down save	DE	Destination

## 12.31 Slot 3 Menu 22: EtherNet/IP Out Mappings

Parameter		Range(⊘)		Default(⇒)			Type						
		OL	RFC-A / S	OL	RFC-A	RFC-S							
3.22.001	Output mapping parameter 1					6042	RW	Num				PT	US
3.22.002	Output mapping parameter 2					1021	RW	Num				PT	US
3.22.003	Output mapping parameter 3					0	RW	Num				PT	US
3.22.004	Output mapping parameter 4					0	RW	Num				PT	US
3.22.005	Output mapping parameter 5					0	RW	Num				PT	US
3.22.006	Output mapping parameter 6					0	RW	Num				PT	US
3.22.007	Output mapping parameter 7					0	RW	Num				PT	US
3.22.008	Output mapping parameter 8					0	RW	Num				PT	US
3.22.009	Output mapping parameter 9					0	RW	Num				PT	US
3.22.010	Output mapping parameter 10					0	RW	Num				PT	US
3.22.011	Output mapping parameter 11					0	RW	Num				PT	US
3.22.012	Output mapping parameter 12					0	RW	Num				PT	US
3.22.013	Output mapping parameter 13					0	RW	Num				PT	US
3.22.014	Output mapping parameter 14					0	RW	Num				PT	US
3.22.015	Output mapping parameter 15					0	RW	Num				PT	US
3.22.016	Output mapping parameter 16					0	RW	Num				PT	US
3.22.017	Output mapping parameter 17					0	RW	Num				PT	US
3.22.018	Output mapping parameter 18					0	RW	Num				PT	US
3.22.019	Output mapping parameter 19					0	RW	Num				PT	US
3.22.020	Output mapping parameter 20					0	RW	Num				PT	US
3.22.021	Output mapping parameter 21					0	RW	Num				PT	US
3.22.022	Output mapping parameter 22					0	RW	Num				PT	US
3.22.023	Output mapping parameter 23					0	RW	Num				PT	US
3.22.024	Output mapping parameter 24					0	RW	Num				PT	US
3.22.025	Output mapping parameter 25					0	RW	Num				PT	US
3.22.026	Output mapping parameter 26					0	RW	Num				PT	US
3.22.027	Output mapping parameter 27					0	RW	Num				PT	US
3.22.028	Output mapping parameter 28					0	RW	Num				PT	US
3.22.029	Output mapping parameter 29					0	RW	Num				PT	US
3.22.030	Output mapping parameter 30					0	RW	Num				PT	US
3.22.031	Output mapping parameter 31					0	RW	Num				PT	US
3.22.032	Output mapping parameter 32					0	RW	Num				PT	US

0 to 499999

RW	Read / Write	RO	Read only	Num	Number parameter	Bit	Bit parameter	Txt	Text string	Bin	Binary parameter	FI	Filtered
ND	No default value	NC	Not copied	PT	Protected parameter	RA	Rating dependent	US	User save	PS	Power-down save	DE	Destination

## 12.32 Slot 3 Menu 23: EtherNet/IP Fault Values

Parameter	Range(φ)		Default(⇒)			Type					
	OL	RFC-A / S	OL	RFC-A	RFC-S						
3.23.001	Output fault value 1					RW	Num			PT	US
3.23.002	Output fault value 2					RW	Num			PT	US
3.23.003	Output fault value 3					RW	Num			PT	US
3.23.004	Output fault value 4					RW	Num			PT	US
3.23.005	Output fault value 5					RW	Num			PT	US
3.23.006	Output fault value 6					RW	Num			PT	US
3.23.007	Output fault value 7					RW	Num			PT	US
3.23.008	Output fault value 8					RW	Num			PT	US
3.23.009	Output fault value 9					RW	Num			PT	US
3.23.010	Output fault value 10					RW	Num			PT	US
3.23.011	Output fault value 11					RW	Num			PT	US
3.23.012	Output fault value 12					RW	Num			PT	US
3.23.013	Output fault value 13					RW	Num			PT	US
3.23.014	Output fault value 14					RW	Num			PT	US
3.23.015	Output fault value 15					RW	Num			PT	US
3.23.016	Output fault value 16					RW	Num			PT	US
3.23.017	Output fault value 17					RW	Num			PT	US
3.23.018	Output fault value 18					RW	Num			PT	US
3.23.019	Output fault value 19					RW	Num			PT	US
3.23.020	Output fault value 20					RW	Num			PT	US
3.23.021	Output fault value 21					RW	Num			PT	US
3.23.022	Output fault value 22					RW	Num			PT	US
3.23.023	Output fault value 23					RW	Num			PT	US
3.23.024	Output fault value 24					RW	Num			PT	US
3.23.025	Output fault value 25					RW	Num			PT	US
3.23.026	Output fault value 26					RW	Num			PT	US
3.23.027	Output fault value 27					RW	Num			PT	US
3.23.028	Output fault value 28					RW	Num			PT	US
3.23.029	Output fault value 29					RW	Num			PT	US
3.23.030	Output fault value 30					RW	Num			PT	US
3.23.031	Output fault value 31					RW	Num			PT	US
3.23.032	Output fault value 32					RW	Num			PT	US

RW	Read / Write	RO	Read only	Num	Number parameter	Bit	Bit parameter	Txt	Text string	Bin	Binary parameter	FI	Filtered
ND	No default value	NC	Not copied	PT	Protected parameter	RA	Rating dependent	US	User save	PS	Power-down save	DE	Destination

## 12.33 Slot 3 Menu 24: Profinet Set-up

Parameter	Range(φ)		Default(⇒)			Type						
	OL	RFC-A / S	OL	RFC-A	RFC-S							
3.24.001	Enable Profinet Interface	Off (0) or On (1)		On (1)		RW	Bit				US	
3.24.002	Reset Profinet	Off (0) or On (1)		Off (0)		RW	Bit			NC		
3.24.003	Profinet Default	Off (0) or On (1)		Off (0)		RW	Bit			NC		
3.24.004	Configuration error	No error (0), Input mapping (1), Output mapping (2), Data Size (3), Param Config (4)		No error (0)		RO	Txt			NC	PT	
3.24.005	Cyclic data transfers per second	0 to 65535 Messages/s				RO	Num	ND		NC	PT	
3.24.006	Revision counter	0 to 65535				RO	Num	ND			PT	
3.24.007	Profile ID	0 to 65535		62976		RO	Num				PT	
3.24.008	Installation Date	00-00-00 to 31-12-99				RO	Date	ND			PT	
3.24.009	Profinet Timeout Value	1 to 10000		100		RO	Num				PT	
3.24.010	Profinet Timeout Action	Trip (0), Reserved (1), Clear output (2), Hold last (3), No action (4)		No action (4)		RW	Txt				PT	US
3.24.011	Destination For Timeout Event	This slot (0), Slot 1 (1), Slot 2 (2), Slot 3 (3), Slot 4 (4)		This slot (0)		RW	Txt				PT	US
3.24.012	Profinet Timeout Event Type	No Event (0), Trigger Event (1), Trigger Event 1 (2), Trigger Event 2 (3), Trigger Event 3 (4), Trigger Event 4 (5)		No Event (0)		RW	Txt				PT	US
3.24.026	Profinet Input Consistency Enable	Off (0) or On (1)		Off (0)		RW	Bit				US	
3.24.027	Profinet Input Consistency Trigger	0 to 499999		0		RW	Num				US	
3.24.028	Profinet Output Consistency Enable	Off (0) or On (1)		Off (0)		RW	Bit				US	
3.24.029	Profinet Output Consistency Trigger	0 to 499999		0		RW	Num				US	

RW	Read / Write	RO	Read only	Num	Number parameter	Bit	Bit parameter	Txt	Text string	Bin	Binary parameter	FI	Filtered
ND	No default value	NC	Not copied	PT	Protected parameter	RA	Rating dependent	US	User save	PS	Power-down save	DE	Destination

# 13 Diagnostics

The KI-Compact Display and KI Remote Keypad RTC provide drive status information and drive trip indication for fault diagnosis.

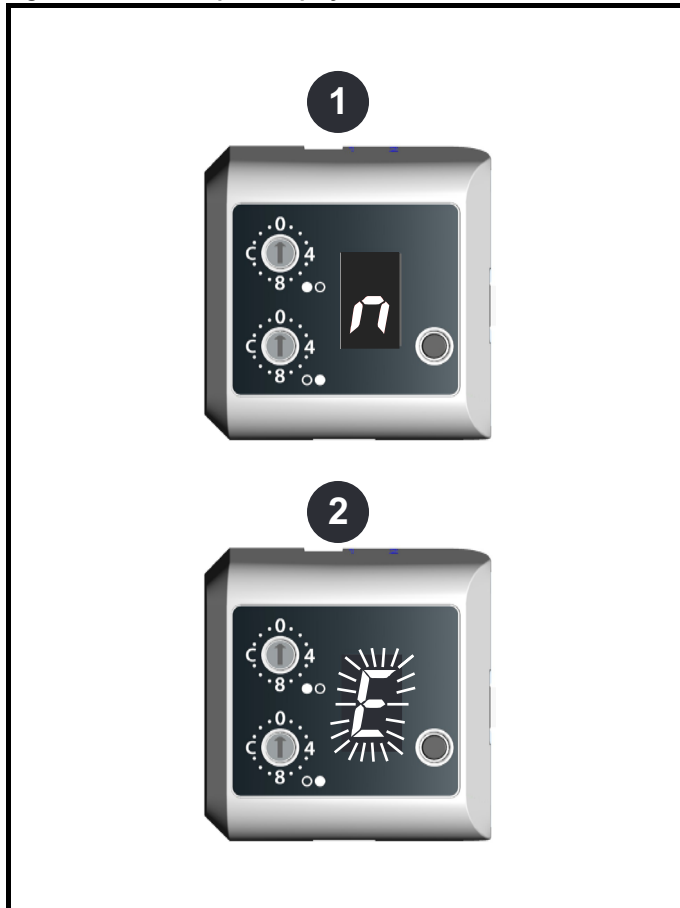


**WARNING**

Users must not attempt to repair a drive if it is faulty, nor carry out fault diagnosis other than through the use of the diagnostic features described in this chapter. If a drive is faulty, it must be returned to an authorized distributor for repair.

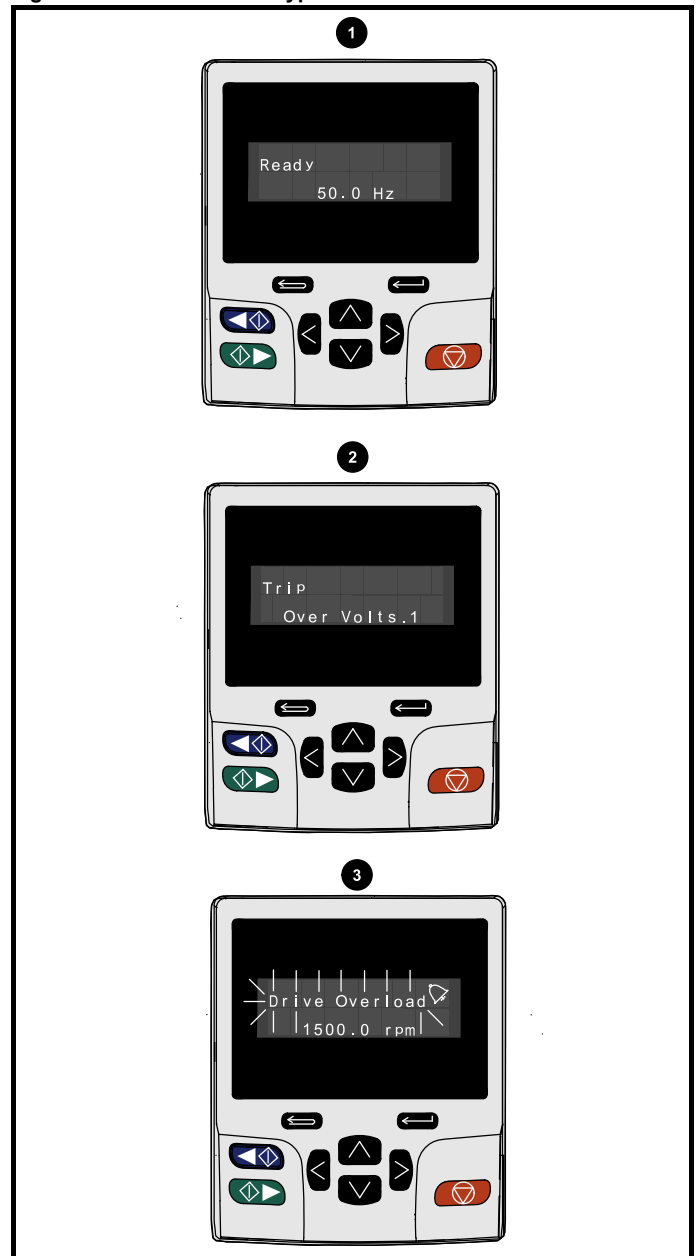
## 13.1 Status modes (KI-Compact Display, KI-Remote Keypad and drive LED status)

Figure 13-1 KI-Compact Display status modes



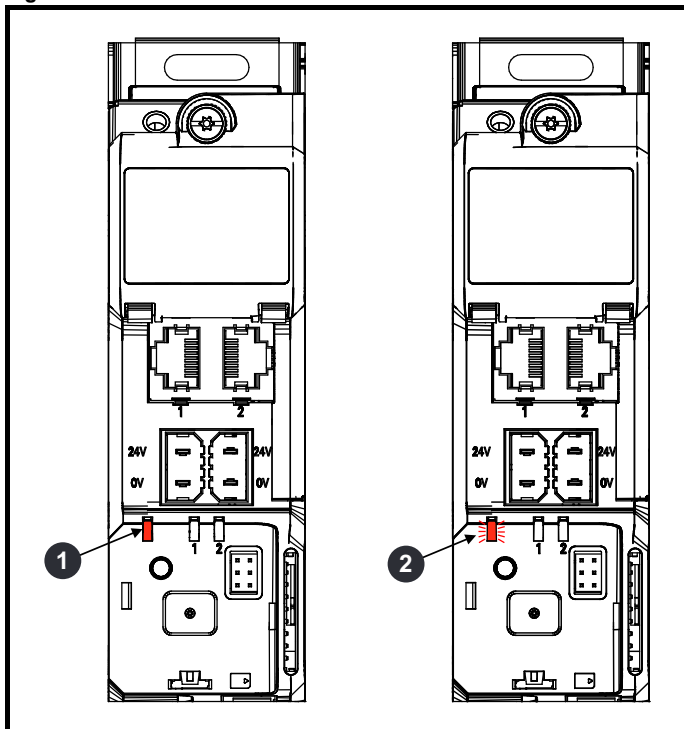
1. Drive OK status
2. Trip status (flashing)

Figure 13-2 KI-Remote Keypad status modes



1. Drive OK status
2. Trip status
3. Alarm status

**Figure 13-3 Location of the status LED**



1. Non flashing: Normal status
2. Flashing: Trip status

### 13.2 Trip indications

The output of the drive is disabled under any trip condition so that the drive stops controlling the motor. If the motor is running when the trip occurs it will coast to a stop.

During a trip condition, where a KI-Compact Display is being used, a trip or HF (hardware fault) condition is indicated as a scrolling message, with an E prefix followed by a serial communications trip code and sub trip code where relevant. Refer to Table 13-1 for further information.

**Table 13-1 Trips associated with xxyzz sub-trip number**

Display character	Trip code	Separator	Sub-trip code
	Range 1 to 254		Range 1 to 65535
	Range 1 to 99		

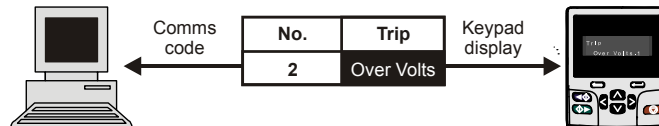
During a trip condition, where a KI-Remote Keypad is being used, the upper row of the display indicates that a trip has occurred and the lower row of the keypad display will display the trip string. Some trips have a sub-trip number to provide additional information about the trip. If a trip has a sub-trip number, the sub-trip number is flashed alternately with the trip string unless there is space on the second row for both the trip string and the sub-trip number in which case both the trip string and sub-trip information is displayed separated by a decimal place.

If a display is not being used, the drive LED Status indicator will flash with 0.5 s duty cycle if the drive has tripped. Refer to Figure 13-3.

Trips are listed alphabetically in Table 13-4 based on the trip indication shown on the drive display. Alternatively, the drive status can be read in Pr 10.001 'Drive OK' using communication protocols. The most recent trip can be read in Pr 10.020 providing a trip number. It must be noted that the hardware trips (HF01 to HF20) do not have trip numbers. The trip number must be checked in Table 13-5 to identify the specific trip.

#### Example

1. Trip code 2 is read from Pr 10.020 via serial communications.
2. Checking Table 13-4 shows Trip 2 is an Over Volts trip.



3. Look up Over Volts in Table 13-4.
4. Perform checks detailed under *Diagnosis*.

### 13.3 Identifying a trip / trip source

Some trips only contain a trip string whereas some other trips have a trip string along with a sub-trip number which provides the user with additional information about the trip.

A trip can be generated from a control system or from a power system. The sub-trip number associated with the trips listed in Table 13-2 is in the form xxyzz and used to identify the source of the trip.

**Table 13-2 Trips associated with xxyzz sub-trip number**

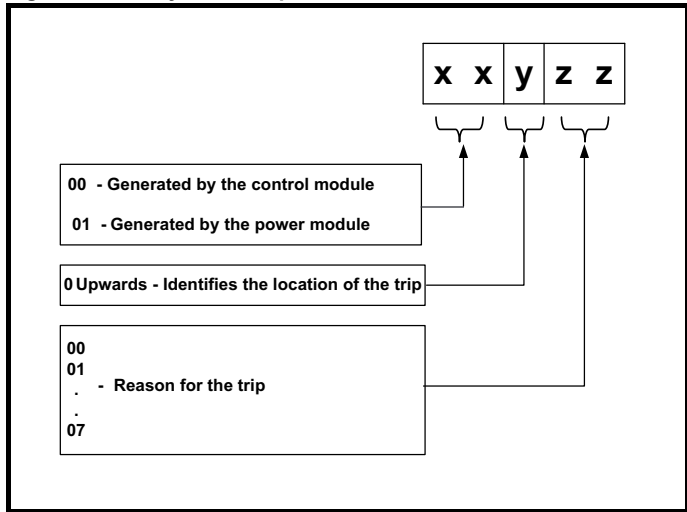
Over Volts	Oht dc bus
OI ac	Phase Loss
OI Brake	Power Comms
PSU	OI Snubber
Oht Inverter	Temp Feedback
Oht Power	Power Data
Oht Control	

The digits xx are 00 for a trip generated by the control system. For a single drive (not part of a multi-power module drive), if the trip is related to the power system then xx will have a value of 01, when displayed the leading zeros are suppressed.

The y digit is used to identify the location of a trip which is generated by a rectifier module connected to a power module (if xx is non zero). For a control system trip (xx is zero), the y digit, where relevant is defined for each trip. If not relevant, the y digit will have a value of zero.

The zz digits give the reason for the trip and are defined in each trip description.

**Figure 13-4 Key to sub-trip number**



For example, if the drive has tripped and the lower line of the display shows 'Oht Control.2', with the help of Table 13-3 below the trip can be interpreted as; an over temperature has been detected; the trip was generated by fault in the control module, the control board thermistor 2 over temperature. For further information on individual sub-trips, refer to the diagnosis column in Table 13-4.

**Table 13-3 Sub-trip identification**

Source	xx	y	zz	Description
Control system	00	0	01	Control board thermistor 1 over temperature
Control system	00	0	02	Control board thermistor 2 over temperature
Control system	00	0	03	Control board thermistor 3 over temperature

## 13.4 Trips, Sub-trip numbers

Table 13-4 Trip indications

Trip	Diagnosis																											
<b>App Menu Changed</b>	<b>Customization table for an application module has changed</b>																											
217	<p>The <i>App Menu Changed</i> trip indicates that the customization table for an application menu has changed. The menu that has been changed can be identified by the sub-trip number.</p> <table border="1"> <thead> <tr> <th>Sub-trip</th> <th>Reason</th> </tr> </thead> <tbody> <tr> <td>1</td> <td>Menu 18</td> </tr> <tr> <td>2</td> <td>Menu 19</td> </tr> <tr> <td>3</td> <td>Menu 20</td> </tr> </tbody> </table> <p>If more than one menu has changed the lowest menu has priority. Drive user parameters must be saved to prevent this trip on the next power-up.</p> <p><b>Recommended actions:</b></p> <ul style="list-style-type: none"> <li>Reset the trip and perform a parameter save to accept the new settings</li> </ul>	Sub-trip	Reason	1	Menu 18	2	Menu 19	3	Menu 20																			
Sub-trip	Reason																											
1	Menu 18																											
2	Menu 19																											
3	Menu 20																											
<b>Autotune 1</b>	<b>Position feedback did not change or required speed could not be reached</b>																											
11	<p>The drive has tripped during an autotune. The cause of the trip can be identified from the sub-trip number.</p> <table border="1"> <thead> <tr> <th>Sub-trip</th> <th>Reason</th> <th>Recommended actions</th> </tr> </thead> <tbody> <tr> <td>1</td> <td>The position feedback did not change when position feedback is being used during rotating auto-tune.</td> <td>Ensure that the motor is free to turn (i.e. mechanical brake is released). Check that the position feedback is selected correctly and operates correctly.</td> </tr> <tr> <td>2</td> <td>The motor did not reach the required speed during mechanical load measurement.</td> <td>Ensure that the motor is free to turn and that the static load plus inertia is not too large for the drive to accelerate within the test time.</td> </tr> <tr> <td>3</td> <td>The required commutation signal edge could not be found during a rotating auto-tune with a Commutation Only position feedback device.</td> <td>Check that the position feedback signals are connected correctly.</td> </tr> <tr> <td>4</td> <td>The required movement angle cannot be produced during a minimal movement test.</td> <td>Reduce the angular movement required.</td> </tr> <tr> <td>5</td> <td>The second part of the minimal movement test during auto-tuning cannot locate the motor flux position accurately.</td> <td>Reduce the angular movement required.</td> </tr> <tr> <td>6</td> <td>The phasing offset angle is measured twice during a stationary auto-tune and the results are not within 30° of each other.</td> <td>If a minimal movement test is being used and excessive motor movement is occurring during the test reduce the required angle movement. Otherwise try and increase the required angle movement.</td> </tr> <tr> <td>7</td> <td>The motor is moving when a phasing test on enable is selected and the drive is enabled, but the motor is still moving at a speed above the zero speed threshold.</td> <td>Ensure that the motor is stationary before the drive is enabled.</td> </tr> <tr> <td>8</td> <td>An auto-tune has been attempted while the AMC is selected.</td> <td>Set <i>AMC Select</i> (31.001) to zero to deselect the AMC.</td> </tr> </tbody> </table> <p><b>Recommended actions:</b></p> <ul style="list-style-type: none"> <li>Ensure the motor is free to turn i.e. mechanical brake was released</li> <li>Ensure Pr <b>03.026</b> and Pr <b>03.038</b> are set correctly (or appropriate 2<sup>nd</sup> motor map parameters)</li> <li>Check feedback device wiring is correct</li> <li>Check encoder mechanical coupling to the motor</li> </ul>	Sub-trip	Reason	Recommended actions	1	The position feedback did not change when position feedback is being used during rotating auto-tune.	Ensure that the motor is free to turn (i.e. mechanical brake is released). Check that the position feedback is selected correctly and operates correctly.	2	The motor did not reach the required speed during mechanical load measurement.	Ensure that the motor is free to turn and that the static load plus inertia is not too large for the drive to accelerate within the test time.	3	The required commutation signal edge could not be found during a rotating auto-tune with a Commutation Only position feedback device.	Check that the position feedback signals are connected correctly.	4	The required movement angle cannot be produced during a minimal movement test.	Reduce the angular movement required.	5	The second part of the minimal movement test during auto-tuning cannot locate the motor flux position accurately.	Reduce the angular movement required.	6	The phasing offset angle is measured twice during a stationary auto-tune and the results are not within 30° of each other.	If a minimal movement test is being used and excessive motor movement is occurring during the test reduce the required angle movement. Otherwise try and increase the required angle movement.	7	The motor is moving when a phasing test on enable is selected and the drive is enabled, but the motor is still moving at a speed above the zero speed threshold.	Ensure that the motor is stationary before the drive is enabled.	8	An auto-tune has been attempted while the AMC is selected.	Set <i>AMC Select</i> (31.001) to zero to deselect the AMC.
Sub-trip	Reason	Recommended actions																										
1	The position feedback did not change when position feedback is being used during rotating auto-tune.	Ensure that the motor is free to turn (i.e. mechanical brake is released). Check that the position feedback is selected correctly and operates correctly.																										
2	The motor did not reach the required speed during mechanical load measurement.	Ensure that the motor is free to turn and that the static load plus inertia is not too large for the drive to accelerate within the test time.																										
3	The required commutation signal edge could not be found during a rotating auto-tune with a Commutation Only position feedback device.	Check that the position feedback signals are connected correctly.																										
4	The required movement angle cannot be produced during a minimal movement test.	Reduce the angular movement required.																										
5	The second part of the minimal movement test during auto-tuning cannot locate the motor flux position accurately.	Reduce the angular movement required.																										
6	The phasing offset angle is measured twice during a stationary auto-tune and the results are not within 30° of each other.	If a minimal movement test is being used and excessive motor movement is occurring during the test reduce the required angle movement. Otherwise try and increase the required angle movement.																										
7	The motor is moving when a phasing test on enable is selected and the drive is enabled, but the motor is still moving at a speed above the zero speed threshold.	Ensure that the motor is stationary before the drive is enabled.																										
8	An auto-tune has been attempted while the AMC is selected.	Set <i>AMC Select</i> (31.001) to zero to deselect the AMC.																										
<b>Autotune 2</b>	<b>Position feedback direction incorrect</b>																											
12	<p>The drive has tripped during a rotating autotune. The cause of the trip can be identified from the associated sub-trip number.</p> <table border="1"> <thead> <tr> <th>Sub-trip</th> <th>Reason</th> </tr> </thead> <tbody> <tr> <td>1</td> <td>The position feedback direction is incorrect when position feedback is being used during a rotating autotune</td> </tr> <tr> <td>2</td> <td>A SINCOS encoder with comms is being used for position feedback and the comms position is rotating in the opposite direction to the sine wave based position.</td> </tr> </tbody> </table> <p><b>Recommended actions:</b></p> <ul style="list-style-type: none"> <li>Check motor cable wiring is correct</li> <li>Check feedback device wiring is correct</li> <li>Swap any two motor phases</li> </ul>	Sub-trip	Reason	1	The position feedback direction is incorrect when position feedback is being used during a rotating autotune	2	A SINCOS encoder with comms is being used for position feedback and the comms position is rotating in the opposite direction to the sine wave based position.																					
Sub-trip	Reason																											
1	The position feedback direction is incorrect when position feedback is being used during a rotating autotune																											
2	A SINCOS encoder with comms is being used for position feedback and the comms position is rotating in the opposite direction to the sine wave based position.																											

Trip	Diagnosis								
<b>Autotune 3</b>	<b>Measured inertia has exceeded the parameter range or commutation signals changed in wrong direction</b>								
13	The drive has tripped during a rotating autotune or mechanical load measurement test. The cause of the trip can be identified from the associated sub-trip number.								
	<table border="1"> <thead> <tr> <th>Sub-trip</th> <th>Reason</th> </tr> </thead> <tbody> <tr> <td>1</td> <td>Measured inertia has exceeded the parameter range during a mechanical load measurement</td> </tr> <tr> <td>2</td> <td>The commutation signals changed in the wrong direction during a rotating autotune</td> </tr> <tr> <td>3</td> <td>The mechanical load test has been unable to identify the motor inertia.</td> </tr> </tbody> </table>	Sub-trip	Reason	1	Measured inertia has exceeded the parameter range during a mechanical load measurement	2	The commutation signals changed in the wrong direction during a rotating autotune	3	The mechanical load test has been unable to identify the motor inertia.
	Sub-trip	Reason							
	1	Measured inertia has exceeded the parameter range during a mechanical load measurement							
2	The commutation signals changed in the wrong direction during a rotating autotune								
3	The mechanical load test has been unable to identify the motor inertia.								
<b>Recommended actions for sub-trip 2:</b>									
<ul style="list-style-type: none"> <li>• Check motor cable wiring is correct</li> <li>• Check feedback device U,V and W commutation signal wiring is correct</li> </ul>									
<b>Recommended actions for sub-trip 3:</b>									
<ul style="list-style-type: none"> <li>• Increase the test level</li> <li>• If the test was carried out at standstill repeat the test with the motor rotating within the recommended speed range</li> </ul>									
<b>Autotune 4</b>	<b>Drive encoder U commutation signal fail</b>								
14	A position feedback device with commutation signals is being used (i.e. AB Servo, FD Servo, FR Servo, SC Servo, or Commutations only encoder) and the U commutation signal did not change during a rotating autotune.								
	<b>Recommended actions:</b> <ul style="list-style-type: none"> <li>• Check feedback device U commutation signal wiring is correct (Encoder terminals 7 and 8)</li> </ul>								
<b>Autotune 5</b>	<b>Drive encoder V commutation signal fail</b>								
15	A position feedback device with commutation signals is being used (i.e. AB Servo, FD Servo, FR Servo, SC Servo, or Commutations only encoder) and the V commutation signal did not change during a rotating autotune.								
	<b>Recommended actions:</b> <ul style="list-style-type: none"> <li>• Check feedback device V commutation signal wiring is correct (Encoder terminals 9 and 10)</li> </ul>								
<b>Autotune 6</b>	<b>Drive encoder W commutation signal fail</b>								
16	A position feedback device with commutation signals is being used (i.e. AB Servo, FD Servo, FR Servo, SC Servo, or Commutations only encoder) and the W commutation signal did not change during a rotating autotune.								
	<b>Recommended actions:</b> <ul style="list-style-type: none"> <li>• Check feedback device W commutation signal wiring is correct (Encoder terminals 11 and 12)</li> </ul>								
<b>Autotune 7</b>	<b>Motor number of poles / position feedback resolution set incorrectly</b>								
17	An <i>Autotune 7</i> trip is initiated during a rotating autotune, if the motor poles or the position feedback resolution have been set up incorrectly where position feedback is being used.								
	<b>Recommended actions:</b> <ul style="list-style-type: none"> <li>• Check line per revolution for feedback device</li> <li>• Check the number of poles in Pr <b>05.011</b></li> </ul>								
<b>Autotune Stopped</b>	<b>Autotune test stopped before completion</b>								
18	The drive was prevented from completing an autotune test, because either the drive enable or the drive run were removed.								
	<b>Recommended actions:</b> <ul style="list-style-type: none"> <li>• Check the drive enable signal (terminal 2 &amp;6) were active during the autotune</li> <li>• Check the run command was active in Pr <b>08.005</b> during autotune</li> </ul>								
<b>Brake R Too Hot</b>	<b>Braking resistor overload timed out (I<sup>2</sup>t)</b>								
19	The <i>Brake R Too Hot</i> indicates that braking resistor overload has timed out. The value in <i>Braking Resistor Thermal Accumulator</i> (10.039) is calculated using <i>Braking Resistor Rated Power</i> (10.030), <i>Braking Resistor Thermal Time Constant</i> (10.031) and <i>Braking Resistor Resistance</i> (10.061). The <i>Brake R Too Hot</i> trip is initiated when <i>Braking Resistor Thermal Accumulator</i> (10.039) reaches 100 %.								
	<b>Recommended actions:</b> <ul style="list-style-type: none"> <li>• Ensure the values entered in Pr <b>10.030</b>, Pr <b>10.031</b> and Pr <b>10.061</b> are correct</li> <li>• If an external thermal protection device is being used and the braking resistor software overload protection is not required, set Pr <b>10.030</b>, Pr <b>10.031</b> or Pr <b>10.061</b> to 0 to disable the trip.</li> </ul>								

Trip	Diagnosis										
<b>CAM</b>	<b>Advanced motion controller CAM failure</b>										
	The <i>CAM</i> trip indicates that the advanced motion controller CAM has detected a problem.										
	<table border="1"> <thead> <tr> <th>Sub-trip</th> <th>Reason</th> </tr> </thead> <tbody> <tr> <td>1</td> <td><i>AMC Cam Start Index</i> (35.001) &gt; <i>AMC Cam Size</i> (35.003) or <i>AMC Cam Start Position In Segment</i> (35.002) &gt; Cam Table In for the start index</td> </tr> <tr> <td>2</td> <td><i>AMC CAM Index</i> (35.007) has been made to change by more than 2 in one sample</td> </tr> <tr> <td>3</td> <td>The rate of change at a segment boundary has exceeded the maximum value</td> </tr> <tr> <td>4</td> <td>The sum of the <i>AMC Cam Position In Segment</i> (35.008) and the change of master position has exceeded the maximum value.</td> </tr> </tbody> </table>	Sub-trip	Reason	1	<i>AMC Cam Start Index</i> (35.001) > <i>AMC Cam Size</i> (35.003) or <i>AMC Cam Start Position In Segment</i> (35.002) > Cam Table In for the start index	2	<i>AMC CAM Index</i> (35.007) has been made to change by more than 2 in one sample	3	The rate of change at a segment boundary has exceeded the maximum value	4	The sum of the <i>AMC Cam Position In Segment</i> (35.008) and the change of master position has exceeded the maximum value.
Sub-trip	Reason										
1	<i>AMC Cam Start Index</i> (35.001) > <i>AMC Cam Size</i> (35.003) or <i>AMC Cam Start Position In Segment</i> (35.002) > Cam Table In for the start index										
2	<i>AMC CAM Index</i> (35.007) has been made to change by more than 2 in one sample										
3	The rate of change at a segment boundary has exceeded the maximum value										
4	The sum of the <i>AMC Cam Position In Segment</i> (35.008) and the change of master position has exceeded the maximum value.										
<b>Card Access</b>	<b>SD Card Write fail</b>										
	The <i>Card Access</i> trip indicates that the drive was unable to access the SD Card. If the trip occurs during the data transfer to the card then the file being written may be corrupted. If the trip occurs when the data being transferred to the drive then the data transfer may be incomplete. If a parameter file is transferred to the drive and this trip occurs during the transfer, the parameters are not saved to non-volatile memory, and so the original parameters can be restored by powering the drive down and up again.										
	<p><b>Recommended actions:</b></p> <ul style="list-style-type: none"> <li>• Check SD Card is installed / located correctly</li> <li>• Replace the SD Card</li> </ul>										
<b>Card Boot</b>	<b>The Menu 0 parameter modification cannot be saved to the SD Card</b>										
	Menu 0 changes are automatically saved on exiting edit mode.										
	The <i>Card Boot</i> trip will occur if a write to a Menu 0 parameter has been initiated via the keypad by exiting edit mode and Pr <b>11.042</b> is set for auto or boot mode, but the necessary boot file has not been created on the SD Card to take the new parameter value. This occurs when Pr <b>11.042</b> is changed to Auto (3) or Boot (4) mode, but the drive is not subsequently reset. The action of resetting the trip will create the necessary file and prevent further trips.										
	<p><b>Recommended actions:</b></p> <ul style="list-style-type: none"> <li>• Ensure that Pr <b>11.042</b> is correctly set, and then reset the drive to create the necessary file on the SD Card</li> <li>• Re-attempt the parameter write to the Menu 0 parameter</li> </ul>										
<b>Card Busy</b>	<b>SD Card cannot be accessed as it is being accessed by an option module</b>										
	The <i>Card Busy</i> trip indicates that an attempt has been made to access a file on SD Card, but the SD Card is already being accessed by an Option Module, such as one of the Applications modules. No data is transferred.										
	<p><b>Recommended actions:</b></p> <ul style="list-style-type: none"> <li>• Wait for the option module to finish accessing the SD Card and re-attempt the required function</li> </ul>										
<b>Card Compare</b>	<b>SD Card file/data is different to the one in the drive</b>										
	A compare has been carried out between a file on the SD Card and the drive. A Card Compare trip is initiated if the parameters on the SD Card are different to the drive.										
	<p><b>Recommended actions:</b></p> <ul style="list-style-type: none"> <li>• Set Pr <b>mm.000</b> to 0 and reset the trip</li> <li>• Check to ensure the correct data block on the SD Card has been used for the compare.</li> </ul>										
<b>Card Data Exists</b>	<b>SD Card data location already contains data</b>										
	The <i>Card Data Exists</i> trip indicates that an attempt has been made to store data on an SD Card in a data block which already contains data. No data is transferred. The data should be erased from the card first to prevent this trip.										
	<p><b>Recommended actions:</b></p> <ul style="list-style-type: none"> <li>• Erase the data in data location</li> <li>• Write data to an alternative data location</li> </ul>										
<b>Card Drive Mode</b>	<b>SD Card parameter set not compatible with current drive mode</b>										
	The <i>Card Drive Mode</i> trip is produced during a compare if the drive mode in the data block on the SD Card is different from the current drive mode. This trip is also produced if an attempt is made to transfer parameters from an SD Card to the drive if the operating mode in the data block is outside the allowed range of operating modes.										
	<p><b>Recommended actions:</b></p> <ul style="list-style-type: none"> <li>• Ensure the destination drive supports the drive operating mode in the parameter file.</li> <li>• Clear the value in Pr <b>mm.000</b> and reset the drive.</li> <li>• Ensure destination drive operating mode is the same as the source parameter file.</li> </ul>										

Trip	Diagnosis								
<b>Card Error</b>	<b>SD Card data structure error</b>								
182	The <i>Card Error</i> trip indicates that an attempt has been made to access an SD Card but an error has been detected in the data structure on the card. Resetting the trip will cause the drive to erase and create the correct folder structure. The cause of the trip can be identified by the sub-trip.								
	<table border="1"> <thead> <tr> <th>Sub-trip</th> <th>Reason</th> </tr> </thead> <tbody> <tr> <td>1</td> <td>The required folder and file structure is not present</td> </tr> <tr> <td>2</td> <td>The &lt;000&gt; file is corrupted.</td> </tr> <tr> <td>3</td> <td>Two or more files in the &lt;MCDF&gt; folder have the same file identification number.</td> </tr> </tbody> </table>	Sub-trip	Reason	1	The required folder and file structure is not present	2	The <000> file is corrupted.	3	Two or more files in the <MCDF> folder have the same file identification number.
	Sub-trip	Reason							
	1	The required folder and file structure is not present							
2	The <000> file is corrupted.								
3	Two or more files in the <MCDF> folder have the same file identification number.								
<b>Recommended actions:</b>									
	<ul style="list-style-type: none"> <li>Erase all the data blocks and re-attempt the process</li> <li>Ensure the card is located correctly</li> <li>Replace the SD Card</li> </ul>								
<b>Card Full</b>	<b>SD Card full</b>								
184	The <i>Card Full</i> trip indicates that an attempt has been made to create a data block on an SD Card, but there is not enough space left on the card.								
	<b>Recommended actions:</b> <ul style="list-style-type: none"> <li>Delete a data block or the entire SD Card to create space</li> <li>Use a different SD Card</li> </ul>								
<b>Card No Data</b>	<b>SD Card data not found</b>								
183	The <i>Card No Data</i> trip indicates that an attempt has been made to access non-existent file or block on an SD Card. No data is transferred.								
	<b>Recommended actions:</b> <ul style="list-style-type: none"> <li>Ensure data block number is correct</li> </ul>								
<b>Card Option</b>	<b>SD Card trip; option modules installed are different between source drive and destination drive</b>								
180	The <i>Card Option</i> trip indicates that parameter data or default difference data is being transferred from an SD Card to the drive, but the option module categories are different between source and destination drives. This trip does not stop the data transfer, but is a warning that the data for the option modules that are different will be set to the default values and not the values from the card. This trip also applies if a compare is attempted between the data block and the drive.								
	<b>Recommended actions:</b> <ul style="list-style-type: none"> <li>Ensure the correct option modules are installed.</li> <li>Ensure the option modules are in the same option module slot as the parameter set stored.</li> <li>Press the red reset button to acknowledge that the parameters for one or more of the option modules installed will be at their default values</li> <li>This trip can be suppressed by setting Pr <b>mm.000</b> to 9666 and resetting the drive.</li> </ul>								
<b>Card Product</b>	<b>SD Card data blocks are not compatible with the drive derivative</b>								
175	If <i>Drive Derivative</i> (11.028) or <i>Product Type</i> (11.063) are different between the source and target drives then this trip is initiated either at power-up or when the card is accessed. It will have one of the following sub-trip numbers:								
	<table border="1"> <thead> <tr> <th>Sub-trip</th> <th>Reason</th> </tr> </thead> <tbody> <tr> <td>1</td> <td>If <i>Drive Derivative</i> (11.028) is different between the source and target drives, this trip is initiated either at power-up or when the SD Card is accessed. Data is still transferred, since this is a warning trip; the trip can be suppressed by entering code 9666 in parameter xx.000, and resetting the drive (this applies the warning suppression flag to the card).</td> </tr> <tr> <td>2</td> <td>If <i>Product Type</i> (11.063) is different between the source and target drives or if corruption is detected in the parameter file, this trip is initiated either at power-up or when the SD Card is accessed. This trip can be reset but no data are transferred in either direction between the drive and the card.</td> </tr> <tr> <td>3</td> <td>A Unidrive SP parameter value was found that has no equivalent parameter on the destination drive. Data is still transferred, since this is a warning trip; the trip can be suppressed by entering code 9666 in Pr <b>xx.000</b>, and resetting the drive (this applies the warning suppression flag to the card).</td> </tr> </tbody> </table>	Sub-trip	Reason	1	If <i>Drive Derivative</i> (11.028) is different between the source and target drives, this trip is initiated either at power-up or when the SD Card is accessed. Data is still transferred, since this is a warning trip; the trip can be suppressed by entering code 9666 in parameter xx.000, and resetting the drive (this applies the warning suppression flag to the card).	2	If <i>Product Type</i> (11.063) is different between the source and target drives or if corruption is detected in the parameter file, this trip is initiated either at power-up or when the SD Card is accessed. This trip can be reset but no data are transferred in either direction between the drive and the card.	3	A Unidrive SP parameter value was found that has no equivalent parameter on the destination drive. Data is still transferred, since this is a warning trip; the trip can be suppressed by entering code 9666 in Pr <b>xx.000</b> , and resetting the drive (this applies the warning suppression flag to the card).
	Sub-trip	Reason							
	1	If <i>Drive Derivative</i> (11.028) is different between the source and target drives, this trip is initiated either at power-up or when the SD Card is accessed. Data is still transferred, since this is a warning trip; the trip can be suppressed by entering code 9666 in parameter xx.000, and resetting the drive (this applies the warning suppression flag to the card).							
2	If <i>Product Type</i> (11.063) is different between the source and target drives or if corruption is detected in the parameter file, this trip is initiated either at power-up or when the SD Card is accessed. This trip can be reset but no data are transferred in either direction between the drive and the card.								
3	A Unidrive SP parameter value was found that has no equivalent parameter on the destination drive. Data is still transferred, since this is a warning trip; the trip can be suppressed by entering code 9666 in Pr <b>xx.000</b> , and resetting the drive (this applies the warning suppression flag to the card).								
<b>Recommended actions:</b>									
	<ul style="list-style-type: none"> <li>Use a different SD Card</li> <li>This trip can be suppressed by setting Pr <b>mm.000</b> to 9666 and resetting the drive</li> </ul>								

Trip	Diagnosis								
<b>Card Rating</b>	<b>SD Card Trip; The voltage and / or current rating of the source and destination drives are different</b>								
186	<p>The Card Rating trip indicates that parameter data is being transferred from an SD Card to the drive, but the current and / or voltage ratings are different between source and destination drives. This trip also applies if a compare (using Pr <b>mm.000</b> set to 8yyy) is attempted between the data block on an SD Card and the drive. The Card Rating trip does not stop the data transfer but is a warning that rating specific parameters with the RA attribute may not be transferred to the destination drive.</p> <p><b>Recommended actions:</b></p> <ul style="list-style-type: none"> <li>Reset the drive to clear the trip</li> <li>Ensure that the drive rating dependent parameters have transferred correctly</li> <li>This trip can be suppressed by setting Pr <b>mm.000</b> to 9666 and resetting the drive</li> </ul>								
<b>Card Read Only</b>	<b>SD Card has the Read Only bit set</b>								
181	<p>The <i>Card Read Only</i> trip indicates that an attempt has been made to modify a read-only SD Card or a read-only data block. An SD Card is read-only if the read-only flag has been set.</p> <p><b>Recommended actions:</b></p> <ul style="list-style-type: none"> <li>Clear the read only flag by setting Pr <b>mm.000</b> to 9777 and reset the drive. This will clear the read-only flag for all data blocks in the SD Card</li> </ul>								
<b>Card Slot</b>	<b>SD Card Trip; Option module application program transfer has failed</b>								
174	<p>The <i>Card Slot</i> trip is initiated, if the transfer of an option module application program to or from an application module failed because the option module does not respond correctly. If this happens this trip is produced with the sub-trip indicating the option module slot number.</p> <p><b>Recommended actions:</b></p> <ul style="list-style-type: none"> <li>Ensure the source / destination option module is installed on the correct slot</li> </ul>								
<b>Control Word</b>	<b>Trip initiated from the Control Word (06.042)</b>								
35	<p>The Control Word trip is initiated by setting bit 12 on the control word in Pr <b>06.042</b> when the control word is enabled (Pr <b>06.043</b> = On).</p> <p><b>Recommended actions:</b></p> <ul style="list-style-type: none"> <li>Check the value of Pr <b>06.042</b>.</li> <li>Disable the control word in <i>Control Word Enable</i> (Pr <b>06.043</b>) <ul style="list-style-type: none"> <li>Bit 12 of the control word set to a one causes the drive to trip on Control Word</li> <li>When the control word is enabled, the trip can only be cleared by setting bit 12 to zero</li> </ul> </li> </ul>								
<b>Current Offset</b>	<b>Current feedback offset error</b>								
225	<p>The current feedback offset is too large to be trimmed correctly. The sub-trip relates to the output phase for which the offset error has been detected.</p> <table border="1"> <thead> <tr> <th>Sub-trip</th> <th>Phase</th> </tr> </thead> <tbody> <tr> <td>1</td> <td>U</td> </tr> <tr> <td>2</td> <td>V</td> </tr> <tr> <td>3</td> <td>W</td> </tr> </tbody> </table> <p><b>Recommended actions:</b></p> <ul style="list-style-type: none"> <li>Ensure that there is no possibility of current flowing in the output phases of the drive when the drive is not enabled</li> <li>Hardware fault – Contact the supplier of the drive</li> </ul>	Sub-trip	Phase	1	U	2	V	3	W
Sub-trip	Phase								
1	U								
2	V								
3	W								
<b>Data Changing</b>	<b>Drive parameters are being changed</b>								
97	<p>A user action or a file system write is active that is changing the drive parameters and the drive has been commanded to enable, i.e. <i>Drive Active</i> (10.002) = 1. The user actions that change drive parameters are loading defaults, changing drive mode, or transferring data from an NV memory card or a position feedback device to the drive. The file system actions that will cause this trip to be initiated if the drive is enabled during the transfer are writing a parameter or macro file to the drive, or transferring a derivative or user program to the drive. It should be noted that none of these actions can be started if the drive is active, and so the trip only occurs if the action is started and then the drive is enabled.</p> <p><b>Recommended actions:</b></p> <ul style="list-style-type: none"> <li>Ensure the drive is not enabled when one of the following is being carried out <ul style="list-style-type: none"> <li>Loading defaults</li> <li>Changing drive mode</li> <li>Transferring data from SD Card or position feedback device</li> <li>Transferring user programs</li> </ul> </li> </ul>								

Trip	Diagnosis																											
<b>Derivative ID</b>	<b>Derivative identification error</b>																											
247	There is a problem with the identifier associated with derivative image which customizes the drive. The reason for the trip is given by the sub-trip as follows:																											
	<table border="1"> <thead> <tr> <th>Sub-trip</th> <th>Reason</th> </tr> </thead> <tbody> <tr> <td>1</td> <td>There should be a derivative image in the product but this has been erased.</td> </tr> <tr> <td>2</td> <td>The identifier is out of range.</td> </tr> <tr> <td>3</td> <td>The derivative image has been changed.</td> </tr> </tbody> </table>	Sub-trip	Reason	1	There should be a derivative image in the product but this has been erased.	2	The identifier is out of range.	3	The derivative image has been changed.																			
	Sub-trip	Reason																										
	1	There should be a derivative image in the product but this has been erased.																										
	2	The identifier is out of range.																										
3	The derivative image has been changed.																											
<b>Recommended actions:</b>	Contact the supplier of the drive																											
<b>Derivative Image</b>	<b>Derivative Image error</b>																											
248	The <i>Derivative Image</i> trip indicates that an error has been detected in the derivative image. The sub-trip number indicates the reason for the trip.																											
	<table border="1"> <thead> <tr> <th>Sub-trip</th> <th>Reason</th> <th>Comments</th> </tr> </thead> <tbody> <tr> <td>1 to 52</td> <td>An error has been detected in the derivative image, contact the supplier of the drive.</td> <td></td> </tr> <tr> <td>61</td> <td>The option module fitted in slot 1 is not allowed with the derivative image</td> <td rowspan="4">Occurs when the drive powers-up or the image is programmed. The image tasks will not run.</td> </tr> <tr> <td>62</td> <td>The option module fitted in slot 2 is not allowed with the derivative image</td> </tr> <tr> <td>63</td> <td>The option module fitted in slot 3 is not allowed with the derivative image</td> </tr> <tr> <td>64</td> <td>The option module fitted in slot 4 is not allowed with the derivative image</td> </tr> <tr> <td>70</td> <td>An option module that is required by the derivative image is not fitted in any slot</td> <td rowspan="4">Occurs when the drive powers-up or the image is programmed. The image tasks will not run.</td> </tr> <tr> <td>71</td> <td>An option module specifically required to be fitted in slot 1 not present</td> </tr> <tr> <td>72</td> <td>An option module specifically required to be fitted in slot 2 not present</td> </tr> <tr> <td>73</td> <td>An option module specifically required to be fitted in slot 3 not present</td> </tr> <tr> <td>80 to 81</td> <td>An error has been detected in the derivative image, contact the supplier of the drive.</td> <td></td> </tr> </tbody> </table>	Sub-trip	Reason	Comments	1 to 52	An error has been detected in the derivative image, contact the supplier of the drive.		61	The option module fitted in slot 1 is not allowed with the derivative image	Occurs when the drive powers-up or the image is programmed. The image tasks will not run.	62	The option module fitted in slot 2 is not allowed with the derivative image	63	The option module fitted in slot 3 is not allowed with the derivative image	64	The option module fitted in slot 4 is not allowed with the derivative image	70	An option module that is required by the derivative image is not fitted in any slot	Occurs when the drive powers-up or the image is programmed. The image tasks will not run.	71	An option module specifically required to be fitted in slot 1 not present	72	An option module specifically required to be fitted in slot 2 not present	73	An option module specifically required to be fitted in slot 3 not present	80 to 81	An error has been detected in the derivative image, contact the supplier of the drive.	
	Sub-trip	Reason	Comments																									
	1 to 52	An error has been detected in the derivative image, contact the supplier of the drive.																										
	61	The option module fitted in slot 1 is not allowed with the derivative image	Occurs when the drive powers-up or the image is programmed. The image tasks will not run.																									
	62	The option module fitted in slot 2 is not allowed with the derivative image																										
	63	The option module fitted in slot 3 is not allowed with the derivative image																										
	64	The option module fitted in slot 4 is not allowed with the derivative image																										
	70	An option module that is required by the derivative image is not fitted in any slot	Occurs when the drive powers-up or the image is programmed. The image tasks will not run.																									
	71	An option module specifically required to be fitted in slot 1 not present																										
	72	An option module specifically required to be fitted in slot 2 not present																										
	73	An option module specifically required to be fitted in slot 3 not present																										
	80 to 81	An error has been detected in the derivative image, contact the supplier of the drive.																										
	<b>Recommended action:</b>	Contact the supplier of the drive																										
<b>Destination</b>	<b>Two or more parameters are writing to the same destination parameter</b>																											
199	The Destination trip indicates that destination parameters of two or more functions (Menus 3, 7, 8, 9, 12 or 14) within the drive are writing to the same parameter.																											
	<b>Recommended actions:</b> <ul style="list-style-type: none"> <li>Set Pr <b>mm.000</b> to 'Destinations' or 12001 and check all visible parameters in all menus for parameter write conflicts</li> </ul>																											
<b>Drive Size</b>	<b>Power stage recognition: Unrecognized drive size</b>																											
224	The <i>Drive Size</i> trip indicates that the control PCB has not recognized the drive size of the power circuit to which it is connected.																											
	<b>Recommended action:</b> <ul style="list-style-type: none"> <li>Ensure the drive is programmed to the latest firmware version</li> <li>Hardware fault - return drive to supplier</li> </ul>																											

Trip	Diagnosis																				
<b>EEPROM Fail</b>	<b>Default parameters have been loaded</b>																				
31	The <i>EEPROM Fail</i> trip indicates that default parameters have been loaded. The exact cause/reason of the trip can be identified from the sub-trip number.																				
	<table border="1"> <thead> <tr> <th>Sub-trip</th> <th>Reason</th> </tr> </thead> <tbody> <tr> <td>1</td> <td>The most significant digit of the internal parameter database version number has changed</td> </tr> <tr> <td>2</td> <td>The CRCs applied to the parameter data stored in internal non-volatile memory indicate that a valid set of parameters cannot be loaded</td> </tr> <tr> <td>3</td> <td>The drive mode restored from internal non-volatile memory is outside the allowed range for the product or the derivative image does not allow the previous drive mode</td> </tr> <tr> <td>4</td> <td>The drive derivative image has changed</td> </tr> <tr> <td>5</td> <td>The power stage hardware has changed</td> </tr> <tr> <td>6</td> <td>The internal I/O hardware has changed</td> </tr> <tr> <td>7</td> <td>The position feedback interface hardware has changed</td> </tr> <tr> <td>8</td> <td>The control board hardware has changed</td> </tr> <tr> <td>9</td> <td>The checksum on the non-parameter area of the EEPROM has failed</td> </tr> </tbody> </table>	Sub-trip	Reason	1	The most significant digit of the internal parameter database version number has changed	2	The CRCs applied to the parameter data stored in internal non-volatile memory indicate that a valid set of parameters cannot be loaded	3	The drive mode restored from internal non-volatile memory is outside the allowed range for the product or the derivative image does not allow the previous drive mode	4	The drive derivative image has changed	5	The power stage hardware has changed	6	The internal I/O hardware has changed	7	The position feedback interface hardware has changed	8	The control board hardware has changed	9	The checksum on the non-parameter area of the EEPROM has failed
	Sub-trip	Reason																			
	1	The most significant digit of the internal parameter database version number has changed																			
	2	The CRCs applied to the parameter data stored in internal non-volatile memory indicate that a valid set of parameters cannot be loaded																			
	3	The drive mode restored from internal non-volatile memory is outside the allowed range for the product or the derivative image does not allow the previous drive mode																			
	4	The drive derivative image has changed																			
	5	The power stage hardware has changed																			
	6	The internal I/O hardware has changed																			
	7	The position feedback interface hardware has changed																			
8	The control board hardware has changed																				
9	The checksum on the non-parameter area of the EEPROM has failed																				
The drive holds two banks of user save parameters and two banks of power down save parameters in non-volatile memory. If the last bank of either set of parameters that was saved is corrupted a <i>User Save</i> or <i>Power Down Save</i> trip is produced. If one of these trips occurs the parameters values that were last saved successfully are used. It can take some time to save parameters when requested by the user and if the power is removed from the drive during this process it is possible to corrupt the data in the non-volatile memory.																					
If both banks of user save parameters or both banks of power down save parameters are corrupted or one of the other conditions given in the table above occurs EEPROM Fail.xxx trip is produced. If this trip occurs it is not possible to use the data that has been saved previously, and so the drive will be in lowest allowed drive mode with default parameters. The trip can only be reset if Pr <b>mm.000</b> (mm.000) is set to 10, 11, 1233 or 1244 or if <i>Load Defaults</i> (11.043) is set to a non-zero value.																					
<b>Recommended actions:</b>																					
<ul style="list-style-type: none"> <li>• Default the drive and perform a reset</li> <li>• Allow sufficient time to perform a save before the supply to the drive is removed</li> <li>• If the trip persists - return drive to supplier</li> </ul>																					
<b>Encoder 1</b>	<b>Drive position feedback interface power supply overload</b>																				
189	The <i>Encoder 1</i> trip indicates that the drive encoder power supply has been overloaded. Terminals 13 & 14 of the 15 way D type connector can supply a maximum current of 200 mA @ 15 V or 300 mA @ 8 V and 5 V.																				
	<b>Recommended actions:</b> <ul style="list-style-type: none"> <li>• Check encoder power supply wiring</li> <li>• Disable the termination resistors (Pr <b>03.039</b> set to 0) to reduce current consumption</li> <li>• For 5 V encoders with long cables, select 8 V (Pr <b>03.036</b>) and install a 5 V voltage regulator close to the encoder</li> <li>• Check the encoder specification to confirm if it is compatible with the encoder port power supply current capability</li> <li>• Replace the encoder</li> <li>• Use an external power supply with higher current capability</li> </ul>																				
<b>Encoder 2</b>	<b>Drive encoder (Feedback) wire break</b>																				
190	The <i>Encoder 2</i> trip indicates that the drive has detected a wire break on the 15 way D-type connector on the drive. The exact cause of the trip can be identified from the sub-trip number.																				
	<table border="1"> <thead> <tr> <th>Sub-trip</th> <th>Reason</th> </tr> </thead> <tbody> <tr> <td>1</td> <td>Drive position feedback interface 1 on any input</td> </tr> <tr> <td>2</td> <td>Drive position feedback interface 2 on any input</td> </tr> <tr> <td>11</td> <td>Drive position feedback interface 1 on the A channel</td> </tr> <tr> <td>12</td> <td>Drive position feedback interface 1 on the B channel</td> </tr> <tr> <td>13</td> <td>Drive position feedback interface 1 on the Z channel</td> </tr> </tbody> </table>	Sub-trip	Reason	1	Drive position feedback interface 1 on any input	2	Drive position feedback interface 2 on any input	11	Drive position feedback interface 1 on the A channel	12	Drive position feedback interface 1 on the B channel	13	Drive position feedback interface 1 on the Z channel								
	Sub-trip	Reason																			
	1	Drive position feedback interface 1 on any input																			
	2	Drive position feedback interface 2 on any input																			
	11	Drive position feedback interface 1 on the A channel																			
12	Drive position feedback interface 1 on the B channel																				
13	Drive position feedback interface 1 on the Z channel																				
<b>Recommended actions:</b>																					
<ul style="list-style-type: none"> <li>• Ensure that the position feedback device type selected in Pr <b>03.038</b> is correct for the position feedback device connected to the P1 interface on the drive.</li> <li>• If wire break detection on the drive encoder input is not required, set Pr <b>03.040</b> = XXX0 to disable the Encoder 2 trip</li> <li>• Check cable continuity</li> <li>• Check wiring of feedback signals is correct</li> <li>• Check encoder power supply is set correctly (Pr <b>03.036</b>)</li> <li>• Replace encoder</li> </ul>																					

Trip	Diagnosis						
<b>Encoder 3</b>	<b>Phase offset incorrect while running</b>						
191	The <i>Encoder 3</i> trip indicates that the drive has detected an incorrect UVW phase angle while running (RFC-S mode only) or SINCOS phase error. The feedback device which has caused the trip can be identified by the sub-trip number.						
	<table border="1"> <thead> <tr> <th>Sub-trip</th> <th>Reason</th> </tr> </thead> <tbody> <tr> <td>1</td> <td>Drive position feedback interface 1</td> </tr> <tr> <td>2</td> <td>Drive position feedback interface 2</td> </tr> </tbody> </table>	Sub-trip	Reason	1	Drive position feedback interface 1	2	Drive position feedback interface 2
	Sub-trip	Reason					
1	Drive position feedback interface 1						
2	Drive position feedback interface 2						
<p><b>Recommended actions:</b></p> <ul style="list-style-type: none"> <li>• Check encoder shield connections</li> <li>• Ensure the encoder cable is one uninterrupted cable</li> <li>• Check the encoder signal for noise with an oscilloscope</li> <li>• Check the integrity of the encoder mechanical mounting</li> <li>• For a UVW servo encoder, ensure that the phase rotation of the UVW commutation signals is the same as the phase rotation of the motor</li> <li>• For a SINCOS encoder, ensure that motor and incremental SINCOS connections are correct and that for forward rotation of the motor, the encoder rotates clockwise (when looking at the shaft of the encoder)</li> <li>• Repeat the offset measurement test</li> </ul>							
<b>Encoder 4</b>	<b>Feedback device comms failure</b>						
192	The <i>Encoder 4</i> trip indicates that the encoder communications has timed out or the communications position message transfer time is too long. This trip can also be caused due to wire break in the communication channel between the drive and the encoder. The feedback device which has caused the trip can be identified by the sub-trip number.						
	<table border="1"> <thead> <tr> <th>Sub-trip</th> <th>Reason</th> </tr> </thead> <tbody> <tr> <td>1</td> <td>Drive position feedback interface 1</td> </tr> <tr> <td>2</td> <td>Drive position feedback interface 2</td> </tr> </tbody> </table>	Sub-trip	Reason	1	Drive position feedback interface 1	2	Drive position feedback interface 2
	Sub-trip	Reason					
1	Drive position feedback interface 1						
2	Drive position feedback interface 2						
<p><b>Recommended actions:</b></p> <ul style="list-style-type: none"> <li>• Ensure the encoder power supply setting (Pr <b>03.036</b>) is correct</li> <li>• Complete encoder auto-configuration (Pr <b>03.041</b>)</li> <li>• Check the encoder wiring</li> <li>• Replace the feedback device</li> </ul>							
<b>Encoder 5</b>	<b>Checksum or CRC error</b>						
193	The <i>Encoder 5</i> trip indicates that there is a checksum or CRC error, or the SSI encoder is not ready. The <i>Encoder 5</i> trip can also indicate a wire break to a communications based encoder.						
	<table border="1"> <thead> <tr> <th>Sub-trip</th> <th>Reason</th> </tr> </thead> <tbody> <tr> <td>1</td> <td>Drive position feedback interface 1</td> </tr> <tr> <td>2</td> <td>Drive position feedback interface 2</td> </tr> </tbody> </table>	Sub-trip	Reason	1	Drive position feedback interface 1	2	Drive position feedback interface 2
	Sub-trip	Reason					
1	Drive position feedback interface 1						
2	Drive position feedback interface 2						
<p><b>Recommended actions:</b></p> <ul style="list-style-type: none"> <li>• Check the encoder cable shield connections</li> <li>• Ensure the cable is one uninterrupted cable - remove any connector blocks or if unavoidable minimise the length of any shield pigtailed to the connector block</li> <li>• Check the encoder signal for noise with an oscilloscope</li> <li>• Check the comms resolution setting (Pr <b>03.035</b>)</li> <li>• If using a Hiperface, EnDat encoder carry out an encoder auto-configuration (Pr <b>03.041</b> = Enabled)</li> <li>• Replace the encoder</li> </ul>							
<b>Encoder 6</b>	<b>Encoder has indicated an error</b>						
194	The <i>Encoder 6</i> trip indicates that the encoder has indicated an error or that the power supply has failed to an SSI encoder. The <i>Encoder 6</i> trip can also indicate a wire break to an SSI encoder.						
	<table border="1"> <thead> <tr> <th>Sub-trip</th> <th>Reason</th> </tr> </thead> <tbody> <tr> <td>1</td> <td>Drive position feedback interface 1</td> </tr> <tr> <td>2</td> <td>Drive position feedback interface 2</td> </tr> </tbody> </table>	Sub-trip	Reason	1	Drive position feedback interface 1	2	Drive position feedback interface 2
	Sub-trip	Reason					
1	Drive position feedback interface 1						
2	Drive position feedback interface 2						
<p><b>Recommended actions:</b></p> <ul style="list-style-type: none"> <li>• For SSI encoders, check the wiring and encoder power supply setting (Pr <b>03.036</b>)</li> <li>• Replace the encoder / contact the supplier of the encoder</li> </ul>							

Trip	Diagnosis																
<b>Encoder 7</b>	<b>Set-up parameters for position feedback device have changed</b>																
195	The <i>Encoder 7</i> trip indicates that the set-up parameters for position feedback device has changed. The feedback device which has caused the trip can be identified by the sub-trip number.																
	<table border="1"> <thead> <tr> <th>Sub-trip</th> <th>Reason</th> </tr> </thead> <tbody> <tr> <td>1</td> <td>Drive position feedback interface 1</td> </tr> <tr> <td>2</td> <td>Drive position feedback interface 2</td> </tr> </tbody> </table>	Sub-trip	Reason	1	Drive position feedback interface 1	2	Drive position feedback interface 2										
	Sub-trip	Reason															
1	Drive position feedback interface 1																
2	Drive position feedback interface 2																
<p><b>Recommended actions:</b></p> <ul style="list-style-type: none"> <li>Reset the trip and perform a save.</li> <li>Ensure Pr <b>3.033</b> and Pr <b>03.035</b> are set correctly or carry out an encoder auto-configuration (Pr <b>03.041</b> = Enabled)</li> </ul>																	
<b>Encoder 8</b>	<b>Position feedback interface has timed out</b>																
196	The <i>Encoder 8</i> trip indicates that Position feedback interface communications time exceeds 250 $\mu$ s. The feedback device which has caused the trip can be identified by the sub-trip number.																
	<table border="1"> <thead> <tr> <th>Sub-trip</th> <th>Reason</th> </tr> </thead> <tbody> <tr> <td>1</td> <td>Drive position feedback interface 1</td> </tr> <tr> <td>2</td> <td>Drive position feedback interface 2</td> </tr> </tbody> </table>	Sub-trip	Reason	1	Drive position feedback interface 1	2	Drive position feedback interface 2										
	Sub-trip	Reason															
1	Drive position feedback interface 1																
2	Drive position feedback interface 2																
<p><b>Recommended actions:</b></p> <ul style="list-style-type: none"> <li>Ensure the encoder is connected correctly</li> <li>Ensure that the encoder is compatible</li> <li>Increase baud rate</li> </ul>																	
<b>Encoder 9</b>	<b>Position feedback is selected from a option module slot which does not have a feedback option module installed</b>																
197	The <i>Encoder 9</i> trip indicates that position feedback source selected in Pr <b>03.026</b> (or Pr <b>21.021</b> for the second motor map) is not valid																
	<p><b>Recommended actions:</b></p> <ul style="list-style-type: none"> <li>Check the setting of Pr <b>03.026</b> (or Pr <b>21.021</b> if the second motor parameters have been enabled)</li> <li>Ensure that the option slot selected in Pr <b>03.026</b> has a feedback option module installed</li> </ul>																
<b>Encoder 12</b>	<b>Encoder could not be identified during auto-configuration</b>																
162	The <i>Encoder 12</i> trip indicates that the drive is communicating with the encoder but the encoder type is not recognized.																
	<table border="1"> <thead> <tr> <th>Sub-trip</th> <th>Reason</th> </tr> </thead> <tbody> <tr> <td>1</td> <td>Drive position feedback interface 1</td> </tr> <tr> <td>2</td> <td>Drive position feedback interface 2</td> </tr> </tbody> </table>	Sub-trip	Reason	1	Drive position feedback interface 1	2	Drive position feedback interface 2										
	Sub-trip	Reason															
1	Drive position feedback interface 1																
2	Drive position feedback interface 2																
<p><b>Recommended actions:</b></p> <ul style="list-style-type: none"> <li>Enter the encoder setup parameters manually</li> <li>Check to see the encoder supports auto-configuration</li> </ul>																	
<b>Encoder 13</b>	<b>Data read from the encoder is out of range during auto-configuration</b>																
163	The <i>Encoder 13</i> trip indicates that the data read from the encoder was out of the range during auto-configuration. No parameters will be modified with the data read from the encoder as a result of auto configuration. The tens in the sub-trip number indicate the interface number (i.e. 1 for P1 interface and 2 for P2 interface).																
	<table border="1"> <thead> <tr> <th>Sub-trip</th> <th>Reason</th> </tr> </thead> <tbody> <tr> <td>x1</td> <td>Rotary lines per revolution error</td> </tr> <tr> <td>x2</td> <td>Linear comms pitch error</td> </tr> <tr> <td>x3</td> <td>Linear line pitch error</td> </tr> <tr> <td>x4</td> <td>Rotary turns bits error</td> </tr> <tr> <td>x5</td> <td>Communications bits error</td> </tr> <tr> <td>x6</td> <td>Calculation time is too long</td> </tr> <tr> <td>x7</td> <td>Line delay measured is longer than 5 <math>\mu</math>s</td> </tr> </tbody> </table>	Sub-trip	Reason	x1	Rotary lines per revolution error	x2	Linear comms pitch error	x3	Linear line pitch error	x4	Rotary turns bits error	x5	Communications bits error	x6	Calculation time is too long	x7	Line delay measured is longer than 5 $\mu$ s
	Sub-trip	Reason															
	x1	Rotary lines per revolution error															
	x2	Linear comms pitch error															
	x3	Linear line pitch error															
	x4	Rotary turns bits error															
	x5	Communications bits error															
x6	Calculation time is too long																
x7	Line delay measured is longer than 5 $\mu$ s																
<p><b>Recommended actions:</b></p> <ul style="list-style-type: none"> <li>Enter the encoder setup parameters manually</li> <li>Check to see the encoder supports auto-configuration</li> </ul>																	

Trip	Diagnosis								
<b>External Trip</b>	<b>An External trip is initiated</b>								
	An <i>External Trip</i> has occurred. The cause of the trip can be identified from the sub trip number displayed after the trip string. See table below. An external trip can also be initiated by writing a value of 6 in Pr <b>10.038</b> .								
	<table border="1"> <thead> <tr> <th>Sub-trip</th> <th>Reason</th> </tr> </thead> <tbody> <tr> <td>1</td> <td><i>External Trip Mode</i> (08.010) = 1 or 3 and Safe Torque Off input 1 is low</td> </tr> <tr> <td>2</td> <td><i>External Trip Mode</i> (08.010) = 2 or 3 and Safe Torque Off input 2 is low</td> </tr> <tr> <td>3</td> <td><i>External Trip</i> (10.032) = 1</td> </tr> </tbody> </table>	Sub-trip	Reason	1	<i>External Trip Mode</i> (08.010) = 1 or 3 and Safe Torque Off input 1 is low	2	<i>External Trip Mode</i> (08.010) = 2 or 3 and Safe Torque Off input 2 is low	3	<i>External Trip</i> (10.032) = 1
Sub-trip	Reason								
1	<i>External Trip Mode</i> (08.010) = 1 or 3 and Safe Torque Off input 1 is low								
2	<i>External Trip Mode</i> (08.010) = 2 or 3 and Safe Torque Off input 2 is low								
3	<i>External Trip</i> (10.032) = 1								
6	<p><b>Recommended actions:</b></p> <ul style="list-style-type: none"> <li>• Check the Safe Torque Off signal voltage (on terminals 2 &amp; 6) equals to 24 V.</li> <li>• Check the value of Pr <b>08.009</b> which indicates the digital state of terminals 2 &amp; 6, equates to 'on'.</li> <li>• If external trip detection of the Safe Torque Off input is not required, set Pr <b>08.010</b> to OFF (0).</li> <li>• Check the value of Pr <b>10.032</b>.</li> <li>• Select 'Destinations' (or enter 12001) in Pr <b>mm.000</b> and check for a parameter controlling Pr <b>10.032</b>.</li> <li>• Ensure Pr <b>10.032</b> or Pr <b>10.038</b> (= 6) is not being controlled by serial comms</li> </ul>								
<b>HF01</b>	<b>Data processing error: CPU address error</b>								
	The <i>HF01</i> trip indicates that a CPU address error has occurred. This trip indicates that the control PCB on the drive has failed.								
	<p><b>Recommended actions:</b></p> <ul style="list-style-type: none"> <li>• Hardware fault – Contact the supplier of the drive</li> </ul>								
<b>HF02</b>	<b>Data processing error: DMAC address error</b>								
	The <i>HF02</i> trip indicates that a DMAC address error has occurred. This trip indicates that the control PCB on the drive has failed.								
	<p><b>Recommended actions:</b></p> <ul style="list-style-type: none"> <li>• Hardware fault – Contact the supplier of the drive</li> </ul>								
<b>HF03</b>	<b>Data processing error: Illegal instruction</b>								
	The <i>HF03</i> trip indicates that an illegal instruction has occurred. This trip indicates that the control PCB on the drive has failed.								
	<p><b>Recommended actions:</b></p> <ul style="list-style-type: none"> <li>• Hardware fault – Contact the supplier of the drive</li> </ul>								
<b>HF04</b>	<b>Data processing error: Illegal slot instruction</b>								
	The <i>HF04</i> trip indicates that an illegal slot instruction has occurred. This trip indicates that the control PCB on the drive has failed.								
	<p><b>Recommended actions:</b></p> <ul style="list-style-type: none"> <li>• Hardware fault – Contact the supplier of the drive</li> </ul>								
<b>HF05</b>	<b>Data processing error: Undefined exception</b>								
	The <i>HF05</i> trip indicates that an undefined exception error has occurred. This trip indicates that the control PCB on the drive has failed.								
	<p><b>Recommended actions:</b></p> <ul style="list-style-type: none"> <li>• Hardware fault – Contact the supplier of the drive</li> </ul>								
<b>HF06</b>	<b>Data processing error: Reserved exception</b>								
	The <i>HF06</i> trip indicates that a reserved exception error has occurred. This trip indicates that the control PCB on the drive has failed.								
	<p><b>Recommended actions:</b></p> <ul style="list-style-type: none"> <li>• Hardware fault – Contact the supplier of the drive</li> </ul>								
<b>HF07</b>	<b>Data processing error: Watchdog failure</b>								
	The <i>HF07</i> trip indicates that a watchdog failure has occurred. This trip indicates that the control PCB on the drive has failed.								
	<p><b>Recommended actions:</b></p> <ul style="list-style-type: none"> <li>• Hardware fault – Contact the supplier of the drive</li> </ul>								
<b>HF08</b>	<b>Data processing error: CPU interrupt crash</b>								
	The <i>HF08</i> trip indicates that a CPU interrupt crash has occurred. This trip indicates that the control PCB on the drive has failed.								
	<p><b>Recommended actions:</b></p> <ul style="list-style-type: none"> <li>• Hardware fault – Contact the supplier of the drive</li> </ul>								

Trip	Diagnosis								
<b>HF09</b>	<b>Data processing error: Free store overflow</b> The <i>HF09</i> trip indicates that a free store overflow has occurred. This trip indicates that the control PCB on the drive has failed. <b>Recommended actions:</b> <ul style="list-style-type: none"> <li>Hardware fault – Contact the supplier of the drive</li> </ul>								
<b>HF10</b>	<b>Data processing error: Parameter routing system error</b> The <i>HF10</i> trip indicates that a Parameter routing system error has occurred. This trip indicates that the control PCB on the drive has failed. <b>Recommended actions:</b> <ul style="list-style-type: none"> <li>Hardware fault – Contact the supplier of the drive</li> </ul>								
<b>HF11</b>	<b>Data processing error: Access to EEPROM failed</b> The <i>HF11</i> trip indicates that access to the drive EEPROM has failed. This trip indicates that the control PCB on the drive has failed. <b>Recommended actions:</b> <ul style="list-style-type: none"> <li>Hardware fault – Contact the supplier of the drive</li> </ul>								
<b>HF12</b>	<b>Data processing error: Main program stack overflow</b> The <i>HF12</i> trip indicates that the main program stack over flow has occurred. The stack can be identified by the sub-trip number. This trip indicates that the control PCB on the drive has failed. <table border="1" data-bbox="316 730 896 873"> <thead> <tr> <th>Sub-trip</th> <th>Stack</th> </tr> </thead> <tbody> <tr> <td>1</td> <td>Background tasks</td> </tr> <tr> <td>2</td> <td>Timed tasks</td> </tr> <tr> <td>3</td> <td>Main system interrupts</td> </tr> </tbody> </table> <b>Recommended actions:</b> <ul style="list-style-type: none"> <li>Hardware fault – Contact the supplier of the drive</li> </ul>	Sub-trip	Stack	1	Background tasks	2	Timed tasks	3	Main system interrupts
Sub-trip	Stack								
1	Background tasks								
2	Timed tasks								
3	Main system interrupts								
<b>HF13</b>	<b>Data processing error: Firmware incompatible with hardware</b> The <i>HF13</i> trip indicates that the drive firmware is not compatible with the hardware. This trip indicates that the control PCB on the drive has failed. The sub-trip number gives the actual ID code of the control board hardware. <b>Recommended actions:</b> <ul style="list-style-type: none"> <li>Re-program the drive with the latest version of the drive firmware for <i>Digitax HD M753</i></li> <li>Hardware fault – Contact the supplier of the drive</li> </ul>								
<b>HF14</b>	<b>Data processing error: CPU register bank error</b> The <i>HF14</i> trip indicates that a CPU register bank error has occurred. This trip indicates that the control PCB on the drive has failed. <b>Recommended actions:</b> <ul style="list-style-type: none"> <li>Hardware fault – Contact the supplier of the drive</li> </ul>								
<b>HF15</b>	<b>Data processing error: CPU divide error</b> The <i>HF15</i> trip indicates that a CPU divide error has occurred. This trip indicates that the control PCB on the drive has failed. <b>Recommended actions:</b> <ul style="list-style-type: none"> <li>Hardware fault – Contact the supplier of the drive</li> </ul>								
<b>HF16</b>	<b>Data processing error: RTOS error</b> The <i>HF16</i> trip indicates that a RTOS error has occurred. This trip indicates that the control PCB on the drive has failed. <b>Recommended actions:</b> <ul style="list-style-type: none"> <li>Hardware fault – Contact the supplier of the drive</li> </ul>								
<b>HF17</b>	<b>Data processing error: Clock supplied to the control board is out of specification</b> The <i>HF17</i> trip indicates that the clock supplied to the control board logic is out of specification. This trip indicates that the control PCB on the drive has failed. <b>Recommended actions:</b> <ul style="list-style-type: none"> <li>Hardware fault – Contact the supplier of the drive</li> </ul>								

Trip	Diagnosis								
<b>HF18</b>	<p><b>Data processing error: Internal flash memory has failed</b></p> <p>The <i>HF18</i> trip indicates that the internal flash memory has failed when writing option module parameter data. The reason for the trip can be identified by the sub-trip number.</p> <table border="1" style="width: 100%;"> <thead> <tr> <th style="text-align: center;">Sub-trip</th> <th style="text-align: center;">Reason</th> </tr> </thead> <tbody> <tr> <td style="text-align: center;">1</td> <td>Programming error while writing menu in flash</td> </tr> <tr> <td style="text-align: center;">2</td> <td>Erase flash block containing setup menus failed</td> </tr> <tr> <td style="text-align: center;">3</td> <td>Erase flash block containing application menus failed</td> </tr> </tbody> </table> <p><b>Recommended actions:</b></p> <ul style="list-style-type: none"> <li>Hardware fault - Contact the supplier of the drive.</li> </ul>	Sub-trip	Reason	1	Programming error while writing menu in flash	2	Erase flash block containing setup menus failed	3	Erase flash block containing application menus failed
Sub-trip	Reason								
1	Programming error while writing menu in flash								
2	Erase flash block containing setup menus failed								
3	Erase flash block containing application menus failed								
<b>HF19</b>	<p><b>Data processing error: CRC check on the firmware has failed</b></p> <p>The <i>HF19</i> trip indicates that the CRC check on the drive firmware has failed.</p> <p><b>Recommended actions:</b></p> <ul style="list-style-type: none"> <li>Re-program the drive</li> <li>Hardware fault - Contact the supplier of the drive</li> </ul>								
<b>HF20</b>	<p><b>Data processing error: ASIC is not compatible with the hardware</b></p> <p>The <i>HF20</i> trip indicates that the ASIC version is not compatible with the drive firmware. The ASIC version can be identified from the sub-trip number.</p> <p><b>Recommended actions:</b></p> <ul style="list-style-type: none"> <li>Hardware fault - Contact the supplier of the drive</li> </ul>								
<b>HF23 to HF25</b>	<p><b>Hardware fault</b></p> <p><b>Recommended actions:</b></p> <ul style="list-style-type: none"> <li>If this trip occurs please consult the drive supplier.</li> </ul>								

Trip	Diagnosis																				
<b>Inductance</b>	<b>Inductance measurement out of range or motor saturation not detected</b>																				
8	<p>This trip occurs in RFC-S mode when the drive has detected that the motor inductances are not suitable for the operation being attempted. The trip is either caused because the ratio or difference between Ld and Lq is too small or because the saturation characteristic of the motor cannot be measured.</p> <p>If the inductance ratio or difference is too small this is because one of the following conditions is true:</p> $(No\text{-}load\ Lq\ (05.072) - Ld\ (05.024)) / Ld\ (05.024) < 0.1$ $(No\text{-}load\ Lq\ (05.072) - Ld\ (05.024)) < (K / Full\ Scale\ Current\ Kc\ (11.061))H$ <p>where:</p> <table border="1"> <thead> <tr> <th>Drive Rated voltage (11.033)</th> <th>K</th> </tr> </thead> <tbody> <tr> <td>200 V</td> <td>0.0073</td> </tr> <tr> <td>400 V</td> <td>0.0146</td> </tr> <tr> <td>575 V</td> <td>0.0174</td> </tr> <tr> <td>690 V</td> <td>0.0209</td> </tr> </tbody> </table> <p>If the saturation characteristic of the motor cannot be measured this is because when the flux in the motor is changed the measured value of Ld does change sufficiently due to saturation to be measured. When half of <i>Rated Current</i> (05.007) is applied in the d axis of the motor in each direction the inductance must fall change at least <math>(K / (2 \times Full\ Scale\ Current\ Kc\ (11.061)))</math>.</p> <p>The specific reasons for each of the sub-trips are given in the table below:</p> <table border="1"> <thead> <tr> <th>Sub-trip</th> <th>Reason</th> </tr> </thead> <tbody> <tr> <td>1</td> <td>The inductance ratio or difference is too small when the drive has been started in sensorless mode.</td> </tr> <tr> <td>2</td> <td>The saturation characteristic of the motor cannot be measured when the drive has been started in sensorless mode.</td> </tr> <tr> <td>3</td> <td>The inductance ratio or difference is too small when an attempt is made to determine the location of the motor flux during a stationary auto-tune in RFC-S mode. This trip is also produced when the inductance ratio or inductance difference is too small when carrying out a phasing test on starting in RFC-S mode. If position feedback is being used the measured value for <i>Position Feedback Phase Angle</i> (03.025) may not be reliable. Also the measured values of <i>Ld</i> (05.024) and <i>No-load Lq</i> (05.072) may not correspond to the d and q axis respectively.</td> </tr> <tr> <td>4</td> <td>The direction of the flux in the motor is detected by the change of inductance with different currents. This trip is initiated if the change cannot be detected when an attempt is made to perform a stationary auto-tune when position feedback is being used, or to perform a phasing test on starting in RFC-S mode.</td> </tr> </tbody> </table> <p><b>Recommended actions for sub-trip 1:</b></p> <ul style="list-style-type: none"> <li>Ensure that <i>RFC Low Speed Mode</i> (05.064) is set to Non-salient (1), Current (2) or Current No test (3).</li> </ul> <p><b>Recommended actions for sub-trip 2:</b></p> <ul style="list-style-type: none"> <li>Ensure that <i>RFC Low Speed Mode</i> (05.064) is set to Non-salient (1), Current (2) or Current No test (3).</li> </ul> <p><b>Recommended actions for sub-trip 3:</b></p> <ul style="list-style-type: none"> <li>None. The trip acts as a warning.</li> </ul> <p><b>Recommended actions for sub-trip 4:</b></p> <ul style="list-style-type: none"> <li>Stationary autotune is not possible. Perform a minimal movement or rotating autotune.</li> <li>Phasing test on starting is not possible. Use a position feedback device with commutation signals or absolute position.</li> </ul>	Drive Rated voltage (11.033)	K	200 V	0.0073	400 V	0.0146	575 V	0.0174	690 V	0.0209	Sub-trip	Reason	1	The inductance ratio or difference is too small when the drive has been started in sensorless mode.	2	The saturation characteristic of the motor cannot be measured when the drive has been started in sensorless mode.	3	The inductance ratio or difference is too small when an attempt is made to determine the location of the motor flux during a stationary auto-tune in RFC-S mode. This trip is also produced when the inductance ratio or inductance difference is too small when carrying out a phasing test on starting in RFC-S mode. If position feedback is being used the measured value for <i>Position Feedback Phase Angle</i> (03.025) may not be reliable. Also the measured values of <i>Ld</i> (05.024) and <i>No-load Lq</i> (05.072) may not correspond to the d and q axis respectively.	4	The direction of the flux in the motor is detected by the change of inductance with different currents. This trip is initiated if the change cannot be detected when an attempt is made to perform a stationary auto-tune when position feedback is being used, or to perform a phasing test on starting in RFC-S mode.
	Drive Rated voltage (11.033)	K																			
	200 V	0.0073																			
	400 V	0.0146																			
	575 V	0.0174																			
	690 V	0.0209																			
	Sub-trip	Reason																			
	1	The inductance ratio or difference is too small when the drive has been started in sensorless mode.																			
2	The saturation characteristic of the motor cannot be measured when the drive has been started in sensorless mode.																				
3	The inductance ratio or difference is too small when an attempt is made to determine the location of the motor flux during a stationary auto-tune in RFC-S mode. This trip is also produced when the inductance ratio or inductance difference is too small when carrying out a phasing test on starting in RFC-S mode. If position feedback is being used the measured value for <i>Position Feedback Phase Angle</i> (03.025) may not be reliable. Also the measured values of <i>Ld</i> (05.024) and <i>No-load Lq</i> (05.072) may not correspond to the d and q axis respectively.																				
4	The direction of the flux in the motor is detected by the change of inductance with different currents. This trip is initiated if the change cannot be detected when an attempt is made to perform a stationary auto-tune when position feedback is being used, or to perform a phasing test on starting in RFC-S mode.																				
<b>Inductor Too Hot</b>	<b>The regen inductor has overloaded</b>																				
93	<p>In Regen mode, this trip indicates a regen inductor thermal overload based on the <i>Rated Current</i> (Pr 05.007) and the <i>Inductor Thermal Time Constant</i> (Pr 04.015). Pr 04.019 displays the inductor temperature as a percentage of the maximum value. The drive will trip on <i>Inductor Too Hot</i> when Pr 04.019 gets to 100 %.</p> <p><b>Recommended actions:</b></p> <ul style="list-style-type: none"> <li>Check the load / current through the inductor has not changed.</li> <li>Ensure the <i>Rated Current</i> (Pr 05.007) is not zero.</li> </ul>																				
<b>I/O Overload</b>	<b>Digital output overload</b>																				
26	<p>The <i>I/O Overload</i> trip indicates that the total current drawn from 24 V user supply or from the digital output has exceeded the limit. A trip is initiated if one or more of the following conditions:</p> <ul style="list-style-type: none"> <li>Maximum output current from one digital output is 100 mA.</li> <li>The combined maximum output current from outputs 1 and 2 is 100 mA</li> <li>The combined maximum output current from output 3 and +24 V output is 100 mA</li> </ul> <p><b>Recommended actions:</b></p> <ul style="list-style-type: none"> <li>Check total loads on digital outputs</li> <li>Check control wiring is correct</li> <li>Check output wiring is undamaged</li> </ul>																				

Trip	Diagnosis										
<b>Island</b>	<b>Island condition detected in regen mode</b>										
160	The <i>Island</i> trip indicates that the AC mains is no longer present and the inverter would be an 'islanded' power supply if it continued to operate. The sub-trip indicates the reason for the trip.										
	<table border="1"> <thead> <tr> <th>Sub-trip</th> <th>Description</th> </tr> </thead> <tbody> <tr> <td>1</td> <td>Island detection system has been enabled and detected an island condition</td> </tr> <tr> <td>2</td> <td>The minimum synchronization voltage is non-zero and the supply voltage has been below this threshold and been simulating its own supply synchronization for more than 2.0 s.</td> </tr> </tbody> </table>	Sub-trip	Description	1	Island detection system has been enabled and detected an island condition	2	The minimum synchronization voltage is non-zero and the supply voltage has been below this threshold and been simulating its own supply synchronization for more than 2.0 s.				
	Sub-trip	Description									
1	Island detection system has been enabled and detected an island condition										
2	The minimum synchronization voltage is non-zero and the supply voltage has been below this threshold and been simulating its own supply synchronization for more than 2.0 s.										
<p><b>Recommended actions:</b></p> <ul style="list-style-type: none"> <li>Check the supply / supply connections to the regen drive</li> </ul>											
<b>Keypad Mode</b>	<b>Keypad has been removed when the drive is receiving the speed reference from the keypad</b>										
34	<p>The <i>Keypad Mode</i> trip indicates that the drive is in keypad mode [<i>Reference Selector</i> (01.014) = 4 or 6 or M2 reference selector (21.003 = 4 or 6 if motor map 2 is selected)] and the keypad has been removed or disconnected from the drive.</p> <p><b>Recommended actions:</b></p> <ul style="list-style-type: none"> <li>Re-install keypad and reset</li> <li>Change <i>Reference Selector</i> (01.014) to select the reference from another source</li> </ul>										
<b>Line Sync</b>	<b>Synchronization to the power supply has been lost</b>										
39	<p>The <i>Line Sync</i> trip indicates that the inverter has lost the synchronization with the ac supply in Regen mode.</p> <p><b>Recommended actions:</b></p> <ul style="list-style-type: none"> <li>Check the supply / supply connections to the regen drive</li> </ul>										
<b>Motor Too Hot</b>	<b>Output current overload timed out (<math>I^2t</math>)</b>										
20	<p>The <i>Motor Too Hot</i> trip indicates a motor thermal overload based on the <i>Rated Current</i> (Pr 05.007) and <i>Motor Thermal Time Constant</i> (Pr 04.015). Pr 04.019 displays the motor temperature as a percentage of the maximum value. The drive will trip on <i>Motor Too Hot</i> when Pr 04.019 gets to 100 %.</p> <p><b>Recommended actions:</b></p> <ul style="list-style-type: none"> <li>Ensure the load is not jammed / sticking</li> <li>Check the load on the motor has not changed</li> <li>If seen during an auto-tune test in RFC-S mode, ensure the motor <i>Rated Current</i> in Pr 05.007 is <math>\leq</math> Heavy duty current rating of the drive</li> <li>Tune the <i>Rated Speed</i> (Pr 05.008) (RFC-A mode only)</li> <li>Check feedback signal for noise</li> <li>Ensure the motor rated current is not zero</li> <li>This trip can be disabled and current limiting activated on the motor overload by setting thermal protection mode Pr 04.016 to 1.</li> </ul>										
<b>Name Plate</b>	<b>Electronic nameplate transfer has failed</b>										
176	The <i>Name Plate</i> trip is initiated if an electronic name plate transfer between the drive and the motor has failed. The exact reason for the trip can be identified from the sub-trip number.										
	<table border="1"> <thead> <tr> <th>Sub-trip</th> <th>Reason</th> </tr> </thead> <tbody> <tr> <td>1</td> <td>Not enough memory space to complete the transfer</td> </tr> <tr> <td>2</td> <td>Communication with encoder failed</td> </tr> <tr> <td>3</td> <td>The transfer has failed</td> </tr> <tr> <td>4</td> <td>The checksum of the stored object has failed</td> </tr> </tbody> </table>	Sub-trip	Reason	1	Not enough memory space to complete the transfer	2	Communication with encoder failed	3	The transfer has failed	4	The checksum of the stored object has failed
	Sub-trip	Reason									
1	Not enough memory space to complete the transfer										
2	Communication with encoder failed										
3	The transfer has failed										
4	The checksum of the stored object has failed										
<p><b>Recommended actions:</b></p> <ul style="list-style-type: none"> <li>Ensure that the device encoder memory has at least 128 bytes to store the nameplate data</li> <li>When writing the motor object (Pr mm.000 = 11000), ensure that the device encoder memory has at least 256 bytes to store all the nameplate data.</li> <li>When transferring between option module and encoder, ensure that the option slot has a feedback option module installed.</li> <li>Check if the encoder has been initialized in <i>Position Feedback Initialized</i> (03.076).</li> <li>Verify the encoder wiring.</li> </ul>											
<b>OHt Brake</b>	<b>Braking IGBT over-temperature</b>										
101	<p>The <i>OHt Brake</i> over-temperature trip indicates that braking IGBT over-temperature has been detected based on software thermal model.</p> <p><b>Recommended actions:</b></p> <ul style="list-style-type: none"> <li>Check braking resistor value is greater than or equal to the minimum resistance value</li> </ul>										

Trip	Diagnosis																				
<b>OHT Control</b>	<b>Control stage over temperature</b>																				
23	This <i>OHT Control</i> trip indicates that a control stage over-temperature has been detected. From the sub-trip 'xyzz', the Thermistor location is identified by 'zz'.																				
	<table border="1"> <thead> <tr> <th>Source</th> <th>xx</th> <th>y</th> <th>zz</th> <th>Description</th> </tr> </thead> <tbody> <tr> <td>Control system</td> <td>00</td> <td>0</td> <td>01</td> <td>Control board thermistor 1 over temperature</td> </tr> <tr> <td>Control system</td> <td>00</td> <td>0</td> <td>02</td> <td>Control board thermistor 2 over temperature</td> </tr> <tr> <td>Control system</td> <td>00</td> <td>0</td> <td>03</td> <td>Compact brake resistor thermistor</td> </tr> </tbody> </table>	Source	xx	y	zz	Description	Control system	00	0	01	Control board thermistor 1 over temperature	Control system	00	0	02	Control board thermistor 2 over temperature	Control system	00	0	03	Compact brake resistor thermistor
	Source	xx	y	zz	Description																
	Control system	00	0	01	Control board thermistor 1 over temperature																
Control system	00	0	02	Control board thermistor 2 over temperature																	
Control system	00	0	03	Compact brake resistor thermistor																	
<p><b>Recommended actions:</b></p> <ul style="list-style-type: none"> <li>• Check enclosure / drive fans are still functioning correctly</li> <li>• Check enclosure ventilation paths</li> <li>• Check enclosure door filters</li> <li>• Increase ventilation</li> <li>• Reduce the drive switching frequency</li> <li>• Check ambient temperature</li> </ul>																					
<b>OHT dc bus</b>	<b>DC bus over temperature</b>																				
27	The <i>OHT dc bus</i> trip indicates a DC bus component over temperature based on a software thermal model. The drive includes a thermal protection system to protect the DC bus components within the drive. This includes the effects of the output current and DC bus ripple. The estimated temperature is displayed as a percentage of the trip level in Pr <b>07.035</b> . If this parameter reaches 100 % then an <i>OHT dc bus</i> trip with sub-trip 200 is initiated. The drive will attempt to stop the motor before tripping. If the motor does not stop in 10 seconds the drive trips immediately.																				
	<table border="1"> <thead> <tr> <th>Source</th> <th>xx</th> <th>y</th> <th>zz</th> <th>Description</th> </tr> </thead> <tbody> <tr> <td>Control system</td> <td>00</td> <td>2</td> <td>00</td> <td>DC bus thermal model gives trip with sub-trip 0</td> </tr> </tbody> </table>	Source	xx	y	zz	Description	Control system	00	2	00	DC bus thermal model gives trip with sub-trip 0										
	Source	xx	y	zz	Description																
	Control system	00	2	00	DC bus thermal model gives trip with sub-trip 0																
It is also possible in a multi-power module system for DC bus over-temperature to be detected from within the power stage. From this source the estimated temperature as a percentage of trip is not available and the trip is indicated as follows:																					
<table border="1"> <thead> <tr> <th>Source</th> <th>xx</th> <th>y</th> <th>zz</th> <th>Description</th> </tr> </thead> <tbody> <tr> <td>Control system</td> <td>01</td> <td>0</td> <td>00</td> <td>Power stage gives trip with sub-trip 0</td> </tr> </tbody> </table> <p><b>Recommended actions:</b></p> <ul style="list-style-type: none"> <li>• Check the AC supply voltage balance and levels</li> <li>• Check DC bus ripple level</li> <li>• Reduce duty cycle</li> <li>• Reduce motor load</li> <li>• Check the output current stability. If unstable; <ul style="list-style-type: none"> <li>Check the motor map settings with motor nameplate (Pr <b>05.006</b>, Pr <b>05.007</b>, Pr <b>05.008</b>, Pr <b>05.009</b>, Pr <b>05.010</b>, Pr <b>05.011</b>) – (All Modes)</li> <li>Disable slip compensation (Pr <b>05.027</b> = 0) – (Open loop)</li> <li>Disable dynamic V to F operation (Pr <b>05.013</b> = 0) - (Open loop)</li> <li>Select fixed boost (Pr <b>05.014</b> = Fixed) – (Open loop)</li> <li>Select high stability space vector modulation (Pr <b>05.020</b> = 1) – (Open loop)</li> <li>Disconnect the load and complete a rotating auto-tune (Pr <b>05.012</b>) – (RFC-A, RFC-S)</li> <li>Auto-tune the rated speed value (Pr <b>05.016</b> = 1) – (RFC-A, RFC-S)</li> <li>Reduce speed loop gains (Pr <b>03.010</b>, Pr <b>03.011</b>, Pr <b>03.012</b>) – (RFC-A, RFC-S)</li> <li>Add a speed feedback filter value (Pr <b>03.042</b>) – (RFC-A, RFC-S)</li> <li>Add a current demand filter (Pr <b>04.012</b>) – (RFC-A, RFC-S)</li> <li>Check encoder signals for noise with an oscilloscope (RFC-A, RFC-S)</li> <li>Check encoder mechanical coupling - (RFC-A, RFC-S)</li> </ul> </li> </ul>	Source	xx	y	zz	Description	Control system	01	0	00	Power stage gives trip with sub-trip 0											
Source	xx	y	zz	Description																	
Control system	01	0	00	Power stage gives trip with sub-trip 0																	

Trip	Diagnosis																																			
<b>Oht Inverter</b>	<b>Inverter over temperature based on thermal model</b>																																			
21	This trip indicates that an IGBT junction over-temperature has been detected based on a software thermal model. The sub-trip indicates which model has initiated the trip in the form xxyzz as given below:																																			
	<table border="1"> <thead> <tr> <th>Source</th> <th>xx</th> <th>y</th> <th>zz</th> <th>Description</th> </tr> </thead> <tbody> <tr> <td>Control system</td> <td>00</td> <td>1</td> <td>00</td> <td>Inverter thermal model</td> </tr> <tr> <td>Control system</td> <td>00</td> <td>3</td> <td>00</td> <td>Braking IGBT thermal model</td> </tr> </tbody> </table>	Source	xx	y	zz	Description	Control system	00	1	00	Inverter thermal model	Control system	00	3	00	Braking IGBT thermal model																				
	Source	xx	y	zz	Description																															
	Control system	00	1	00	Inverter thermal model																															
Control system	00	3	00	Braking IGBT thermal model																																
<b>Recommended actions with sub-trip 100:</b>																																				
<ul style="list-style-type: none"> <li>Reduce the selected drive switching frequency</li> <li>Ensure <i>Auto-switching Frequency Change Disable</i> (05.035) is set to Off</li> <li>Reduce duty cycle</li> <li>Increase acceleration / deceleration rates</li> <li>Reduce motor load</li> <li>Check DC bus ripple</li> <li>Ensure all three input phases are present and balanced</li> </ul>																																				
	<b>Recommended actions with sub-trip 300:</b>																																			
	<ul style="list-style-type: none"> <li>Reduce the braking load</li> </ul>																																			
<b>Oht Power</b>	<b>Power stage over temperature</b>																																			
22	This trip indicates that a power stage over-temperature has been detected. From the sub-trip 'xxyzz', the Thermistor location which is indicating the over-temperature is identified by 'zz'. The thermistor numbering is different for a single module type drive (i.e. no parallel board fitted) and a multi-module type drive (i.e. parallel board fitted with one or more power modules) as shown below:																																			
	<b>Single module type drive:</b>																																			
	<table border="1"> <thead> <tr> <th>Source</th> <th>xx</th> <th>y</th> <th>zz</th> <th>Description</th> </tr> </thead> <tbody> <tr> <td>Power system</td> <td>01</td> <td>0</td> <td>zz</td> <td>Thermistor location defined by zz in the power board</td> </tr> <tr> <td>Power system</td> <td>01</td> <td>Rectifier number</td> <td>zz</td> <td>Thermistor location defined by zz in the rectifier</td> </tr> </tbody> </table>	Source	xx	y	zz	Description	Power system	01	0	zz	Thermistor location defined by zz in the power board	Power system	01	Rectifier number	zz	Thermistor location defined by zz in the rectifier																				
	Source	xx	y	zz	Description																															
	Power system	01	0	zz	Thermistor location defined by zz in the power board																															
	Power system	01	Rectifier number	zz	Thermistor location defined by zz in the rectifier																															
	<b>Multi-module type system:</b>																																			
	<table border="1"> <thead> <tr> <th>Source</th> <th>xx</th> <th>y</th> <th>zz</th> <th>Description</th> </tr> </thead> <tbody> <tr> <td>Power system</td> <td>power module number</td> <td>0</td> <td>01</td> <td>U phase power device</td> </tr> <tr> <td>Power system</td> <td>power module number</td> <td>0</td> <td>02</td> <td>V phase power device</td> </tr> <tr> <td>Power system</td> <td>power module number</td> <td>0</td> <td>03</td> <td>W phase power device</td> </tr> <tr> <td>Power system</td> <td>power module number</td> <td>0</td> <td>04</td> <td>Rectifier</td> </tr> <tr> <td>Power system</td> <td>power module number</td> <td>0</td> <td>05</td> <td>General power system</td> </tr> <tr> <td>Power system</td> <td>power module number</td> <td>0</td> <td>00</td> <td>Braking IGBT</td> </tr> </tbody> </table>	Source	xx	y	zz	Description	Power system	power module number	0	01	U phase power device	Power system	power module number	0	02	V phase power device	Power system	power module number	0	03	W phase power device	Power system	power module number	0	04	Rectifier	Power system	power module number	0	05	General power system	Power system	power module number	0	00	Braking IGBT
	Source	xx	y	zz	Description																															
	Power system	power module number	0	01	U phase power device																															
Power system	power module number	0	02	V phase power device																																
Power system	power module number	0	03	W phase power device																																
Power system	power module number	0	04	Rectifier																																
Power system	power module number	0	05	General power system																																
Power system	power module number	0	00	Braking IGBT																																
Note that the power module that has caused the trip cannot be identified except for the braking IGBT temperature measurement																																				
<b>Recommended actions:</b>																																				
<ul style="list-style-type: none"> <li>Check enclosure / drive fans are still functioning correctly</li> <li>Force the heatsink fans to run at maximum speed</li> <li>Check enclosure ventilation paths</li> <li>Check enclosure door filters</li> <li>Increase ventilation</li> <li>Reduce the drive switching frequency</li> <li>Reduce duty cycle</li> <li>Increase acceleration / deceleration rates</li> <li>Use S ramp (Pr <b>02.006</b>)</li> <li>Reduce motor load</li> <li>Check the derating tables and confirm the drive is correctly sized for the application.</li> <li>Use a drive with larger current / power rating</li> </ul>																																				

Trip	Diagnosis													
<b>OI ac</b>	<b>Instantaneous output over current detected</b>													
3	The instantaneous drive output current has exceeded VM_DRIVE_CURRENT[MAX]. This trip cannot be reset until 10 s after the trip was initiated.													
	<table border="1"> <thead> <tr> <th>Source</th> <th>xx</th> <th>y</th> <th>zz</th> <th>Description</th> </tr> </thead> <tbody> <tr> <td>Control system</td> <td>00</td> <td>0</td> <td rowspan="2">00</td> <td rowspan="2">Instantaneous over-current trip when the measured AC current exceeds VM_DRIVE_CURRENT[MAX].</td> </tr> <tr> <td>Power system</td> <td>Power module number</td> <td>0</td> </tr> </tbody> </table>	Source	xx	y	zz	Description	Control system	00	0	00	Instantaneous over-current trip when the measured AC current exceeds VM_DRIVE_CURRENT[MAX].	Power system	Power module number	0
	Source	xx	y	zz	Description									
Control system	00	0	00	Instantaneous over-current trip when the measured AC current exceeds VM_DRIVE_CURRENT[MAX].										
Power system	Power module number	0												
<p><b>Recommended actions:</b></p> <ul style="list-style-type: none"> <li>• Acceleration/deceleration rate is too short</li> <li>• If seen during auto-tune reduce the voltage boost</li> <li>• Check for short circuit on the output cabling</li> <li>• Check integrity of the motor insulation using an insulation tester</li> <li>• Check feedback device wiring</li> <li>• Check feedback device mechanical coupling</li> <li>• Check feedback signals are free from noise</li> <li>• Is motor cable length within limits for the frame size</li> <li>• Reduce the values in the speed loop gain parameters - (Pr <b>03.010</b>, <b>03.011</b>, <b>03.012</b>) or (Pr <b>03.013</b>, <b>03.014</b>, <b>03.015</b>)</li> <li>• Has the phase angle autotune been completed? (RFC-S mode only)</li> <li>• Reduce the values in current loop gain parameters (RFC-A, RFC-S modes only)</li> </ul>														
<b>OI Brake</b>	<b>Braking IGBT over current detected: short circuit protection for the braking IGBT activated</b>													
4	The <i>OI Brake</i> trip indicates that over current has been detected in braking IGBT or braking IGBT protection has been activated. This trip cannot be reset until 10 s after the trip was initiated.													
	<table border="1"> <thead> <tr> <th>Source</th> <th>xx</th> <th>y</th> <th>zz</th> <th>Description</th> </tr> </thead> <tbody> <tr> <td>Power system</td> <td>Power module number</td> <td>0</td> <td>00</td> <td>Braking IGBT instantaneous over-current trip</td> </tr> </tbody> </table>	Source	xx	y	zz	Description	Power system	Power module number	0	00	Braking IGBT instantaneous over-current trip			
	Source	xx	y	zz	Description									
Power system	Power module number	0	00	Braking IGBT instantaneous over-current trip										
<p><b>Recommended actions:</b></p> <ul style="list-style-type: none"> <li>• Check brake resistor wiring</li> <li>• Check braking resistor value is greater than or equal to the minimum resistance value</li> <li>• Check braking resistor insulation</li> </ul>														
<b>OI dc</b>	<b>Power module over current detected from IGBT on state voltage monitoring</b>													
109	The <i>OI dc</i> trip indicates that the short circuit protection for the drive output stage has been activated. The table below shows where the trip has been detected. This trip cannot be reset until 10 s after the trip was initiated.													
	<table border="1"> <thead> <tr> <th>Source</th> <th>xx</th> <th>y</th> <th>zz</th> </tr> </thead> <tbody> <tr> <td>Control system</td> <td>00</td> <td>0</td> <td>00</td> </tr> <tr> <td>Power system</td> <td>Power module number</td> <td>0</td> <td>00</td> </tr> </tbody> </table>	Source	xx	y	zz	Control system	00	0	00	Power system	Power module number	0	00	
	Source	xx	y	zz										
Control system	00	0	00											
Power system	Power module number	0	00											
<p><b>Recommended actions:</b></p> <ul style="list-style-type: none"> <li>• Disconnect the motor cable at the drive end and check the motor and cable insulation with an insulation tester</li> <li>• Replace the drive</li> </ul>														
<b>OI Snubber</b>	<b>Snubber over-current detected</b>													
92	The <i>OI Snubber</i> trip indicates that an over-current condition has been detected in the rectifier snubber circuit. The reason for the trip can be identified by the sub-trip number.													
	<table border="1"> <thead> <tr> <th>Source</th> <th>xx</th> <th>y</th> <th>zz</th> <th>Description</th> </tr> </thead> <tbody> <tr> <td>Power system</td> <td>01</td> <td>Rectifier number*</td> <td>00</td> <td>Rectifier snubber over-current trip detected.</td> </tr> </tbody> </table>	Source	xx	y	zz	Description	Power system	01	Rectifier number*	00	Rectifier snubber over-current trip detected.			
	Source	xx	y	zz	Description									
Power system	01	Rectifier number*	00	Rectifier snubber over-current trip detected.										
<p>* For a parallel power-module system the rectifier number will be one as it is not possible to determine which rectifier has detected the fault.</p> <p><b>Recommended actions:</b></p> <ul style="list-style-type: none"> <li>• Ensure the internal EMC Filter is installed</li> <li>• Ensure the motor cable length does not exceed the maximum for selected switching frequency</li> <li>• Check for supply voltage imbalance</li> <li>• Check for supply disturbance such as notching from a DC drive</li> <li>• Check the motor and motor cable insulation with an insulation tester</li> <li>• Install an output line reactor or sinusoidal filter</li> </ul>														
<b>Option Disable</b>	<b>Option module does not acknowledge during drive mode changeover</b>													
215	The <i>Option Disable</i> trip indicates that the option module did not acknowledge to the drive that communications with the drive has been stopped during the drive mode changeover with in the allocated time.													
	<p><b>Recommended trip:</b></p> <ul style="list-style-type: none"> <li>• Reset the trip</li> <li>• If the trip persists, replace the option module</li> </ul>													

Trip	Diagnosis															
<b>Out Phase Loss</b>	<b>Output phase loss detected</b>															
98	The <i>Out Phase Loss</i> trip indicates that phase loss has been detected at the drive output.															
	<table border="1"> <thead> <tr> <th>Sub-trip</th> <th>Reason</th> </tr> </thead> <tbody> <tr> <td>1</td> <td>U phase detected as disconnected when drive enabled to run.</td> </tr> <tr> <td>2</td> <td>V phase detected as disconnected when drive enabled to run.</td> </tr> <tr> <td>3</td> <td>W phase detected as disconnected when drive enabled to run.</td> </tr> <tr> <td>4</td> <td>Output phase loss detected when the drive is running.</td> </tr> </tbody> </table>	Sub-trip	Reason	1	U phase detected as disconnected when drive enabled to run.	2	V phase detected as disconnected when drive enabled to run.	3	W phase detected as disconnected when drive enabled to run.	4	Output phase loss detected when the drive is running.					
	Sub-trip	Reason														
	1	U phase detected as disconnected when drive enabled to run.														
	2	V phase detected as disconnected when drive enabled to run.														
3	W phase detected as disconnected when drive enabled to run.															
4	Output phase loss detected when the drive is running.															
<b>NOTE</b>	If Pr <b>05.042</b> = 1 the physical output phases are reversed, and so sub-trip 3 refers to physical output phase V and sub-trip 2 refers to physical output phase W.															
<b>Recommended actions:</b>	<ul style="list-style-type: none"> <li>Check motor and drive connections</li> <li>To disable the trip set <i>Output Phase Loss Detection Enable</i> (06.059) = 0</li> </ul>															
<b>Over Speed</b>	<b>Motor speed has exceeded the over speed threshold</b>															
7	In open loop mode, if the <i>Output Frequency</i> (05.001) exceeds the threshold set in <i>Over Speed Threshold</i> (03.008) in either direction an <i>Over Speed</i> trip is produced. In RFC-A and RFC-S mode, if the Speed Feedback (03.002) exceeds the <i>Over Speed Threshold</i> in Pr <b>03.008</b> in either direction an <i>Over Speed</i> trip is produced. If Pr <b>03.008</b> is set to 0.0 the threshold is then equal to 1.2 x the value set in Pr <b>01.006</b> .															
	In RFC-A and RFC-S mode, if an SSI encoder is being used and Pr <b>03.047</b> is set to 0 an <i>Over Speed</i> trip will be produced when the encoder passes through the boundary between its maximum position and zero.															
	<b>Recommended actions:</b> <ul style="list-style-type: none"> <li>Check the motor is not being driven by another part of the system</li> <li>Reduce the <i>Speed Controller Proportional Gain</i> (03.010) to reduce the speed overshoot (RFC-A, RFC-S modes only)</li> <li>If an SSI encoder is being used set Pr <b>03.047</b> to 1</li> </ul> The above description relates to a standard Over Speed trip, however in RFC-S mode it is possible to produce an <i>Over Speed.1</i> trip. This is caused if the speed is allowed to exceed the safe level in RFC-S mode with flux weakening when <i>Enable High Speed Mode</i> (05.022) is set to -1.															
<b>Over Volts</b>	<b>DC bus voltage has exceeded the peak level or maximum continuous level for 15 seconds</b>															
2	The <i>Over Volts</i> trip indicates that the DC bus voltage has exceeded the VM_DC_VOLTAGE[MAX] or VM_DC_VOLTAGE_SET[MAX] for 15 s. The trip threshold varies depending on voltage rating of the drive as shown below.															
	<table border="1"> <thead> <tr> <th>Voltage rating</th> <th>VM_DC_VOLTAGE[MAX]</th> <th>VM_DC_VOLTAGE_SET[MAX]</th> </tr> </thead> <tbody> <tr> <td>200</td> <td>415</td> <td>410</td> </tr> <tr> <td>400</td> <td>830</td> <td>815</td> </tr> <tr> <td>575</td> <td>990</td> <td>970</td> </tr> <tr> <td>690</td> <td>1190</td> <td>1175</td> </tr> </tbody> </table>	Voltage rating	VM_DC_VOLTAGE[MAX]	VM_DC_VOLTAGE_SET[MAX]	200	415	410	400	830	815	575	990	970	690	1190	1175
	Voltage rating	VM_DC_VOLTAGE[MAX]	VM_DC_VOLTAGE_SET[MAX]													
	200	415	410													
	400	830	815													
575	990	970														
690	1190	1175														
<b>Sub-trip Identification</b>																
	<table border="1"> <thead> <tr> <th>Source</th> <th>xx</th> <th>y</th> <th>zz</th> </tr> </thead> <tbody> <tr> <td>Control system</td> <td>00</td> <td>0</td> <td>01: Instantaneous trip when the DC bus voltage exceeds VM_DC_VOLTAGE[MAX].</td> </tr> <tr> <td>Control system</td> <td>00</td> <td>0</td> <td>02: Time delayed trip indicating that the DC bus voltage is above VM_DC_VOLTAGE_SET[MAX].</td> </tr> </tbody> </table>	Source	xx	y	zz	Control system	00	0	01: Instantaneous trip when the DC bus voltage exceeds VM_DC_VOLTAGE[MAX].	Control system	00	0	02: Time delayed trip indicating that the DC bus voltage is above VM_DC_VOLTAGE_SET[MAX].			
Source	xx	y	zz													
Control system	00	0	01: Instantaneous trip when the DC bus voltage exceeds VM_DC_VOLTAGE[MAX].													
Control system	00	0	02: Time delayed trip indicating that the DC bus voltage is above VM_DC_VOLTAGE_SET[MAX].													
<b>Recommended actions:</b>	<ul style="list-style-type: none"> <li>Increase deceleration ramp (Pr <b>00.004</b>)</li> <li>Decrease the braking resistor value (staying above the minimum value)</li> <li>Check nominal AC supply level</li> <li>Check for supply disturbances which could cause the DC bus to rise</li> <li>Check motor insulation using an insulation tester</li> </ul>															

Trip	Diagnosis												
<b>Phase Loss</b>	<b>Supply phase loss</b>												
32	<p>The Phase Loss trip indicates that the drive has detected an input phase loss or large supply imbalance. Phase loss can be detected directly from the supply where the drive has a thyristor base charge system (Frame size 8 and above). If phase loss is detected using this method the drive trips immediately and the xx part of the sub-trip is set to 01. In all sizes of drive phase loss is also detected by monitoring the ripple in the DC bus voltage in which case the drive attempts to stop the drive before tripping unless bit 2 of <i>Action On Trip Detection</i> (10.037) is set to one. When phase loss is detected by monitoring the ripple in the DC bus voltage the xx part of the sub-trip is zero.</p> <table border="1"> <thead> <tr> <th>Source</th> <th>xx</th> <th>y</th> <th>zz</th> </tr> </thead> <tbody> <tr> <td>Control system</td> <td>00</td> <td>0</td> <td>00: Phase loss detected from DC bus ripple</td> </tr> <tr> <td>Power system (1)</td> <td>Power module number</td> <td>Rectifier number (2)</td> <td>00: Phase loss detected directly from the supply</td> </tr> </tbody> </table> <p>(1) Input phase loss detection can be disabled when the drive required to operate from the DC supply or from a single phase supply in <i>Input Phase Loss Detection Mode</i> (06.047).</p> <p>(2) For a parallel power-module system the rectifier number will be one as it is not possible to determine which rectifier has detected the fault.</p> <p>This trip does not occur in regen mode.</p> <p><b>Recommended actions:</b></p> <ul style="list-style-type: none"> <li>• Check the AC supply voltage balance and level at full load</li> <li>• Check the DC bus ripple level with an isolated oscilloscope</li> <li>• Check the output current stability</li> <li>• Check for mechanical resonance with the load</li> <li>• Reduce the duty cycle</li> <li>• Reduce the motor load</li> <li>• Disable the phase loss detection, set Pr <b>06.047</b> to 2.</li> </ul>	Source	xx	y	zz	Control system	00	0	00: Phase loss detected from DC bus ripple	Power system (1)	Power module number	Rectifier number (2)	00: Phase loss detected directly from the supply
	Source	xx	y	zz									
Control system	00	0	00: Phase loss detected from DC bus ripple										
Power system (1)	Power module number	Rectifier number (2)	00: Phase loss detected directly from the supply										
<b>Phasing Error</b>	<b>RFC-S mode phasing failure due to incorrect phase angle</b>												
198	<p>The <i>Phasing Error</i> trip indicates that the phase offset angle in Pr <b>03.025</b> (or Pr <b>21.020</b> if the second motor map is being used) is incorrect if position feedback is being used and the drive is unable to control the motor correctly.</p> <p><b>Recommended actions:</b></p> <ul style="list-style-type: none"> <li>• Check the encoder wiring</li> <li>• Check the encoder signals for noise with an oscilloscope</li> <li>• Check the encoder mechanical coupling</li> <li>• Perform an auto-tune to measure the encoder phase angle or manually enter the correct phase angle into Pr <b>03.025</b></li> <li>• Spurious <i>Phasing Error</i> trips can sometimes be seen in very dynamic applications. This trip can be disabled by setting the over-speed threshold in Pr <b>03.008</b> to a value greater than zero.</li> </ul> <p>If sensorless control is being used this indicates that significant instability has occurred and the motor has accelerated without control.</p> <p><b>Recommended actions:</b></p> <ul style="list-style-type: none"> <li>• Ensure that the motor parameters are set-up correctly.</li> <li>• Reduce the speed controller gains.</li> </ul>												
<b>Power Comms</b>	<b>Communication has been lost / errors detected between power, control and rectifier modules</b>												
90	<p>A <i>Power Comms</i> trip indicates a communications problem within the power system of the drive. The reason for the trip can be identified by the sub-trip number.</p> <table border="1"> <thead> <tr> <th>Type of drive</th> <th>xx</th> <th>y</th> <th>zz</th> </tr> </thead> <tbody> <tr> <td>Single power module system</td> <td>01</td> <td>Rectifier number*</td> <td>00: Excessive communications errors detected by the rectifier module.</td> </tr> </tbody> </table> <p>* For a parallel power-module system the rectifier number will be one as it is not possible to determine which rectifier has detected the fault.</p> <p><b>Recommended actions:</b></p> <ul style="list-style-type: none"> <li>• Hardware fault – Contact the supplier of the drive</li> </ul>	Type of drive	xx	y	zz	Single power module system	01	Rectifier number*	00: Excessive communications errors detected by the rectifier module.				
Type of drive	xx	y	zz										
Single power module system	01	Rectifier number*	00: Excessive communications errors detected by the rectifier module.										

Trip	Diagnosis																																																		
<b>Power Data</b>	<b>Power system configuration data error</b>																																																		
220	The <i>Power Data</i> trip indicates that there is an error in the configuration data stored in the power system.																																																		
	<table border="1"> <thead> <tr> <th>Source</th> <th>xx</th> <th>y</th> <th>zz</th> <th>Description</th> </tr> </thead> <tbody> <tr> <td>Control system</td> <td>00</td> <td>0</td> <td>02</td> <td>There is no data table to be uploaded to the control board</td> </tr> <tr> <td>Control system</td> <td>00</td> <td>0</td> <td>03</td> <td>The power system data table is bigger than the space available in the control pod to store it.</td> </tr> <tr> <td>Control system</td> <td>00</td> <td>0</td> <td>04</td> <td>The size of the table given in the table is incorrect.</td> </tr> <tr> <td>Control system</td> <td>00</td> <td>0</td> <td>05</td> <td>Table CRC error.</td> </tr> <tr> <td>Control system</td> <td>00</td> <td>0</td> <td>06</td> <td>The version number of the generator software that produced the table is too low. i.e. a table from a newer generator is required that includes features that have been added to the table that may not be present.</td> </tr> <tr> <td>Control system</td> <td>00</td> <td>0</td> <td>07</td> <td>The power board data table does not match the power board hardware identifier.</td> </tr> <tr> <td>Power system</td> <td>01</td> <td>0</td> <td>00</td> <td>The power data table used internally by the power module has an error. (For a multi-power module drive this indicates any error with the code tables in the power system).</td> </tr> <tr> <td>Power system</td> <td>01</td> <td>0</td> <td>01</td> <td>The power data table that should be uploaded to the control system on power up has an error.</td> </tr> <tr> <td>Power system</td> <td>01</td> <td>0</td> <td>02</td> <td>The power data table used internally by the power module does not match the hardware identification of the power module.</td> </tr> </tbody> </table>	Source	xx	y	zz	Description	Control system	00	0	02	There is no data table to be uploaded to the control board	Control system	00	0	03	The power system data table is bigger than the space available in the control pod to store it.	Control system	00	0	04	The size of the table given in the table is incorrect.	Control system	00	0	05	Table CRC error.	Control system	00	0	06	The version number of the generator software that produced the table is too low. i.e. a table from a newer generator is required that includes features that have been added to the table that may not be present.	Control system	00	0	07	The power board data table does not match the power board hardware identifier.	Power system	01	0	00	The power data table used internally by the power module has an error. (For a multi-power module drive this indicates any error with the code tables in the power system).	Power system	01	0	01	The power data table that should be uploaded to the control system on power up has an error.	Power system	01	0	02	The power data table used internally by the power module does not match the hardware identification of the power module.
	Source	xx	y	zz	Description																																														
	Control system	00	0	02	There is no data table to be uploaded to the control board																																														
	Control system	00	0	03	The power system data table is bigger than the space available in the control pod to store it.																																														
	Control system	00	0	04	The size of the table given in the table is incorrect.																																														
	Control system	00	0	05	Table CRC error.																																														
	Control system	00	0	06	The version number of the generator software that produced the table is too low. i.e. a table from a newer generator is required that includes features that have been added to the table that may not be present.																																														
	Control system	00	0	07	The power board data table does not match the power board hardware identifier.																																														
	Power system	01	0	00	The power data table used internally by the power module has an error. (For a multi-power module drive this indicates any error with the code tables in the power system).																																														
	Power system	01	0	01	The power data table that should be uploaded to the control system on power up has an error.																																														
Power system	01	0	02	The power data table used internally by the power module does not match the hardware identification of the power module.																																															
<b>Recommended actions:</b>																																																			
<ul style="list-style-type: none"> <li>Hardware fault – Contact the supplier of the drive</li> </ul>																																																			
<b>Power Down Save</b>	<b>Power down save error</b>																																																		
37	The <i>Power Down Save</i> trip indicates that an error has been detected in the power down save parameters saved in non-volatile memory.																																																		
	<b>Recommended actions:</b> <ul style="list-style-type: none"> <li>Perform a 1001 save in Pr <b>mm.000</b> to ensure that the trip doesn't occur the next time the drive is powered up.</li> </ul>																																																		
<b>PSU</b>	<b>Internal power supply fault</b>																																																		
5	The <i>PSU</i> trip indicates that one or more internal power supply rails are outside limits or overloaded.																																																		
	<table border="1"> <thead> <tr> <th>Source</th> <th>xx</th> <th>y</th> <th>zz</th> <th>Description</th> </tr> </thead> <tbody> <tr> <td>Control system</td> <td>00</td> <td>0</td> <td rowspan="2">00</td> <td>Internal power supply overload</td> </tr> <tr> <td>Power system</td> <td>Power module number</td> <td>Rectifier number*</td> <td>Rectifier internal power supply overload</td> </tr> </tbody> </table>	Source	xx	y	zz	Description	Control system	00	0	00	Internal power supply overload	Power system	Power module number	Rectifier number*	Rectifier internal power supply overload																																				
	Source	xx	y	zz	Description																																														
	Control system	00	0	00	Internal power supply overload																																														
Power system	Power module number	Rectifier number*	Rectifier internal power supply overload																																																
* For a parallel power-module system the rectifier number will be zero as it is not possible to determine which rectifier has detected the fault.																																																			
<b>Recommended actions:</b> <ul style="list-style-type: none"> <li>Remove any option modules and perform a reset</li> <li>Remove encoder connection and perform a reset</li> <li>Hardware fault within the drive – return the drive to the supplier</li> </ul>																																																			
<b>PSU 24V</b>	<b>24V internal power supply overload</b>																																																		
9	The total user load of the drive and option modules has exceeded the internal 24 V power supply limit. The user load consists of the drive digital outputs and main encoder supply.																																																		
	<b>Recommended actions:</b> <ul style="list-style-type: none"> <li>Reduce the load and reset</li> <li>Provide an external 24 V power supply on control terminal 2</li> <li>Remove all option modules</li> </ul>																																																		

Trip	Diagnosis												
<b>Reserved</b>	<b>Reserved trips</b>												
<p>01 95 104 – 108 161, 165-168 170 – 173 222 228 - 246</p>	<p>These trip numbers are reserved trip numbers for future use. These trips should not be used by the user application programs.</p> <table border="1"> <thead> <tr> <th>Trip Number</th> <th>Description</th> </tr> </thead> <tbody> <tr> <td>01</td> <td>Reserved resettable trip</td> </tr> <tr> <td>95</td> <td>Reserved resettable trip</td> </tr> <tr> <td>104 - 108</td> <td>Reserved resettable trip</td> </tr> <tr> <td>170 - 173</td> <td>Reserved resettable trip</td> </tr> <tr> <td>228 - 246</td> <td>Reserved non-resettable trip</td> </tr> </tbody> </table>	Trip Number	Description	01	Reserved resettable trip	95	Reserved resettable trip	104 - 108	Reserved resettable trip	170 - 173	Reserved resettable trip	228 - 246	Reserved non-resettable trip
Trip Number	Description												
01	Reserved resettable trip												
95	Reserved resettable trip												
104 - 108	Reserved resettable trip												
170 - 173	Reserved resettable trip												
228 - 246	Reserved non-resettable trip												
<b>Resistance</b>	<b>Measured resistance has exceeded the parameter range</b>												
33	<p>This trip indicates that either the value being used for motor stator resistance is too high or that an attempt to do a test involving measuring motor stator resistance has failed. The maximum for the stator resistance parameters is generally higher than the maximum value that can be used in the control algorithms. If the value exceeds <math>(V_{FS} / \sqrt{2}) / \text{Full Scale Current } Kc</math> (11.061), where <math>V_{FS}</math> is the full scale DC bus voltage then this trip is initiated. If the value is the result of a measurement made by the drive then sub-trip 1 is applied, or if it is because the parameter has been changed by the user then sub-trip 3 is applied. During the stator resistance section of auto-tuning an additional test is performed to measure the drive inverter characteristics to provide the compensation necessary for dead-times. If the inverter characteristic measurement fails then sub-trip 2 is applied.</p> <table border="1"> <thead> <tr> <th>Sub-trip</th> <th>Reason</th> </tr> </thead> <tbody> <tr> <td>1</td> <td>Measured stator resistance exceeded the allowed range</td> </tr> <tr> <td>2</td> <td>It was not possible to measure the inverter characteristic</td> </tr> <tr> <td>3</td> <td>The stator resistance associated with the presently selected motor map exceeds the allowed range</td> </tr> </tbody> </table> <p><b>Recommended actions:</b></p> <ul style="list-style-type: none"> <li>• Check that the value that has been entered in the stator resistance does not exceed the allowed range (for the presently selected motor map)</li> <li>• Check the motor cable / connections</li> <li>• Check the integrity of the motor stator winding using a insulation tester</li> <li>• Check the motor phase to phase resistance at the drive terminals</li> <li>• Check the motor phase to phase resistance at the motor terminals</li> <li>• Ensure the stator resistance of the motor falls within the range of the drive model</li> <li>• Select fixed boost mode (Pr <b>05.014</b> = Fixed) and verify the output current waveforms with an oscilloscope</li> <li>• Replace the motor</li> </ul>	Sub-trip	Reason	1	Measured stator resistance exceeded the allowed range	2	It was not possible to measure the inverter characteristic	3	The stator resistance associated with the presently selected motor map exceeds the allowed range				
Sub-trip	Reason												
1	Measured stator resistance exceeded the allowed range												
2	It was not possible to measure the inverter characteristic												
3	The stator resistance associated with the presently selected motor map exceeds the allowed range												
<b>Slot3 Different</b>	<b>Ethernet interface in slot 3 has changed</b>												
254	<p>The <i>Slot3 Different</i> trip indicates that the Ethernet interface in slot 3 has changed / not found. The reason for the trip can be identified by the sub-trip number.</p> <table border="1"> <thead> <tr> <th>Sub-trip</th> <th>Reason</th> </tr> </thead> <tbody> <tr> <td>1</td> <td>No module was installed previously</td> </tr> <tr> <td>2</td> <td>A module with the same identifier is installed, but the set-up menu for this option slot has been changed, and so default parameters have been loaded for this menu.</td> </tr> <tr> <td>3</td> <td>A module with the same identifier is installed, but the applications menu for this option slot has been changed, and so default parameters have been loaded for this menu.</td> </tr> <tr> <td>4</td> <td>A module with the same identifier is installed, but the set-up and applications menu for this option slot have been changed, and so default parameters have been loaded for these menus.</td> </tr> <tr> <td>&gt;99</td> <td>Shows the identifier of the module previously installed.</td> </tr> </tbody> </table> <p><b>Recommended actions:</b></p> <ul style="list-style-type: none"> <li>• Turn off the power, ensure that the correct option module is installed in the option slot and re-apply the power.</li> <li>• Confirm that the currently installed option module is correct, ensure the option module parameters are set correctly and perform a <i>User Save</i> in Pr <b>mm.000</b>.</li> <li>• If the trip persists - Contact the supplier of the drive.</li> </ul>	Sub-trip	Reason	1	No module was installed previously	2	A module with the same identifier is installed, but the set-up menu for this option slot has been changed, and so default parameters have been loaded for this menu.	3	A module with the same identifier is installed, but the applications menu for this option slot has been changed, and so default parameters have been loaded for this menu.	4	A module with the same identifier is installed, but the set-up and applications menu for this option slot have been changed, and so default parameters have been loaded for these menus.	>99	Shows the identifier of the module previously installed.
Sub-trip	Reason												
1	No module was installed previously												
2	A module with the same identifier is installed, but the set-up menu for this option slot has been changed, and so default parameters have been loaded for this menu.												
3	A module with the same identifier is installed, but the applications menu for this option slot has been changed, and so default parameters have been loaded for this menu.												
4	A module with the same identifier is installed, but the set-up and applications menu for this option slot have been changed, and so default parameters have been loaded for these menus.												
>99	Shows the identifier of the module previously installed.												

Trip	Diagnosis																																																																																																																																										
252	<p data-bbox="352 149 831 176"><b>Ethernet interface in slot 3 has detected a fault</b></p> <p data-bbox="352 180 1506 233">The <i>Slot3 Error</i> trip indicates that the Ethernet interface in slot 3 on the drive has detected an error. The reason for the trip can be identified by the sub-trip number.</p> <table border="1" data-bbox="360 247 1503 1661"> <thead> <tr> <th data-bbox="365 254 501 281">Sub-trip</th> <th data-bbox="501 254 868 281">Trip string</th> <th data-bbox="868 254 1498 281">Description</th> </tr> </thead> <tbody> <tr><td>100</td><td>Link Loss</td><td>Network link has been lost</td></tr> <tr><td>101</td><td>E/IP Timeout</td><td>An EtherNet/IP RPI timeout trip has occurred</td></tr> <tr><td>102</td><td>E/IP Read Param</td><td>Invalid read consistency parameter</td></tr> <tr><td>103</td><td>E/IP Write Param</td><td>Invalid write consistency parameter</td></tr> <tr><td>104</td><td>E/IP Fault</td><td>An unexpected EtherNet/IP error has occurred</td></tr> <tr><td>105</td><td>Modbus Timeout</td><td>The Modbus connection has timed out</td></tr> <tr><td>106</td><td>DA-RT Timeout</td><td>DA-RX Rx link has timeout</td></tr> <tr><td>107</td><td>DA-RT Rx Late</td><td>Rx data was received late</td></tr> <tr><td>108</td><td>INIT Switch</td><td>Ethernet switch initialisation error</td></tr> <tr><td>109</td><td>INIT PTP</td><td>IEEE1588 (Precision Time Protocol) initialisation error</td></tr> <tr><td>110</td><td>INIT DA-RT</td><td>Cyclic data initialisation error</td></tr> <tr><td>111</td><td>INIT Modbus</td><td>Modbus TCP initialisation error</td></tr> <tr><td>112</td><td>INIT SMTP</td><td>Email (SMTP) initialisation error</td></tr> <tr><td>113</td><td>INIT EtherNet/IP</td><td>Ethernet/IP initialisation error</td></tr> <tr><td>114</td><td>INIT TCP/IP</td><td>TCP/IP initialisation error</td></tr> <tr><td>115</td><td>Ethernet Failure</td><td>Ethernet controller initialisation error</td></tr> <tr><td>116</td><td>E/IP PLC IDLE</td><td>Ethernet/IP PLC Idle</td></tr> <tr><td>117</td><td>Sync Task ORun</td><td>Synchronous task overrun</td></tr> <tr><td>118</td><td>INIT Param Chann</td><td>Parameter channel initialization error</td></tr> <tr><td>119</td><td>Link Overload</td><td>Too many links to be handled in the same cycle</td></tr> <tr><td>120</td><td>Mcast Over Limit</td><td>Too many multicast addresses being used</td></tr> <tr><td>121</td><td>Init Profinet</td><td>Profinet initialisation error</td></tr> <tr><td>122</td><td>Profinet Start</td><td>Profinet start error</td></tr> <tr><td>123</td><td>Profinet Plug</td><td>Profinet failed to load the slots</td></tr> <tr><td>124</td><td>Invalid IM</td><td>Invalid Identification and Maintenance data</td></tr> <tr><td>125</td><td>CPM Watchdog</td><td>Profinet cyclic timeout error</td></tr> <tr><td>200</td><td>Software Fault</td><td>Software Fault</td></tr> <tr><td>201</td><td>BG Overrun</td><td>Background task overrun</td></tr> <tr><td>202</td><td>Firmware Invalid</td><td>Firmware is not compatible for the hardware version</td></tr> <tr><td>203</td><td>Drive Unknown</td><td>Unknown drive type</td></tr> <tr><td>204</td><td>DriveUnsupported</td><td>Unsupported drive type</td></tr> <tr><td>205</td><td>Mode Unknown</td><td>Unknown drive mode</td></tr> <tr><td>206</td><td>Mode Unsupported</td><td>Unsupported drive mode</td></tr> <tr><td>207</td><td>FLASH Error</td><td>Corrupted Non-volatile FLASH</td></tr> <tr><td>208</td><td>Database Init</td><td>Database initialization error</td></tr> <tr><td>209</td><td>File System Init</td><td>File system initialization error</td></tr> <tr><td>210</td><td>Mem Allocation</td><td>Memory allocation error</td></tr> <tr><td>211</td><td>Filesystem Error</td><td>File system error</td></tr> <tr><td>212</td><td>Config Save</td><td>Configuration file save error</td></tr> <tr><td>213</td><td>Over Temperature</td><td>Option module over temperature</td></tr> <tr><td>214</td><td>Drive Timeout</td><td>The drive has not responded within watchdog period</td></tr> <tr><td>215</td><td>eCMP Comms Error</td><td>eCMP communication failure</td></tr> <tr><td>216</td><td>TO eCMP Slot1</td><td>eCMP communication to slot 1 timeout</td></tr> <tr><td>217</td><td>TO eCMP Slot2</td><td>eCMP communication to slot 2 timeout</td></tr> <tr><td>228</td><td>EEPROM Error</td><td>EEPROM Initialisation error</td></tr> </tbody> </table> <p data-bbox="352 1688 596 1715"><b>Recommended actions:</b></p> <ul data-bbox="352 1715 1287 1766" style="list-style-type: none"> <li>• Identify the reason for the trip from the trip string or from sub-trip number and resolve the error.</li> <li>• Reset the trip, If the trip persists, Hardware fault - Contact the supplier of the drive.</li> </ul>	Sub-trip	Trip string	Description	100	Link Loss	Network link has been lost	101	E/IP Timeout	An EtherNet/IP RPI timeout trip has occurred	102	E/IP Read Param	Invalid read consistency parameter	103	E/IP Write Param	Invalid write consistency parameter	104	E/IP Fault	An unexpected EtherNet/IP error has occurred	105	Modbus Timeout	The Modbus connection has timed out	106	DA-RT Timeout	DA-RX Rx link has timeout	107	DA-RT Rx Late	Rx data was received late	108	INIT Switch	Ethernet switch initialisation error	109	INIT PTP	IEEE1588 (Precision Time Protocol) initialisation error	110	INIT DA-RT	Cyclic data initialisation error	111	INIT Modbus	Modbus TCP initialisation error	112	INIT SMTP	Email (SMTP) initialisation error	113	INIT EtherNet/IP	Ethernet/IP initialisation error	114	INIT TCP/IP	TCP/IP initialisation error	115	Ethernet Failure	Ethernet controller initialisation error	116	E/IP PLC IDLE	Ethernet/IP PLC Idle	117	Sync Task ORun	Synchronous task overrun	118	INIT Param Chann	Parameter channel initialization error	119	Link Overload	Too many links to be handled in the same cycle	120	Mcast Over Limit	Too many multicast addresses being used	121	Init Profinet	Profinet initialisation error	122	Profinet Start	Profinet start error	123	Profinet Plug	Profinet failed to load the slots	124	Invalid IM	Invalid Identification and Maintenance data	125	CPM Watchdog	Profinet cyclic timeout error	200	Software Fault	Software Fault	201	BG Overrun	Background task overrun	202	Firmware Invalid	Firmware is not compatible for the hardware version	203	Drive Unknown	Unknown drive type	204	DriveUnsupported	Unsupported drive type	205	Mode Unknown	Unknown drive mode	206	Mode Unsupported	Unsupported drive mode	207	FLASH Error	Corrupted Non-volatile FLASH	208	Database Init	Database initialization error	209	File System Init	File system initialization error	210	Mem Allocation	Memory allocation error	211	Filesystem Error	File system error	212	Config Save	Configuration file save error	213	Over Temperature	Option module over temperature	214	Drive Timeout	The drive has not responded within watchdog period	215	eCMP Comms Error	eCMP communication failure	216	TO eCMP Slot1	eCMP communication to slot 1 timeout	217	TO eCMP Slot2	eCMP communication to slot 2 timeout	228	EEPROM Error	EEPROM Initialisation error
Sub-trip	Trip string	Description																																																																																																																																									
100	Link Loss	Network link has been lost																																																																																																																																									
101	E/IP Timeout	An EtherNet/IP RPI timeout trip has occurred																																																																																																																																									
102	E/IP Read Param	Invalid read consistency parameter																																																																																																																																									
103	E/IP Write Param	Invalid write consistency parameter																																																																																																																																									
104	E/IP Fault	An unexpected EtherNet/IP error has occurred																																																																																																																																									
105	Modbus Timeout	The Modbus connection has timed out																																																																																																																																									
106	DA-RT Timeout	DA-RX Rx link has timeout																																																																																																																																									
107	DA-RT Rx Late	Rx data was received late																																																																																																																																									
108	INIT Switch	Ethernet switch initialisation error																																																																																																																																									
109	INIT PTP	IEEE1588 (Precision Time Protocol) initialisation error																																																																																																																																									
110	INIT DA-RT	Cyclic data initialisation error																																																																																																																																									
111	INIT Modbus	Modbus TCP initialisation error																																																																																																																																									
112	INIT SMTP	Email (SMTP) initialisation error																																																																																																																																									
113	INIT EtherNet/IP	Ethernet/IP initialisation error																																																																																																																																									
114	INIT TCP/IP	TCP/IP initialisation error																																																																																																																																									
115	Ethernet Failure	Ethernet controller initialisation error																																																																																																																																									
116	E/IP PLC IDLE	Ethernet/IP PLC Idle																																																																																																																																									
117	Sync Task ORun	Synchronous task overrun																																																																																																																																									
118	INIT Param Chann	Parameter channel initialization error																																																																																																																																									
119	Link Overload	Too many links to be handled in the same cycle																																																																																																																																									
120	Mcast Over Limit	Too many multicast addresses being used																																																																																																																																									
121	Init Profinet	Profinet initialisation error																																																																																																																																									
122	Profinet Start	Profinet start error																																																																																																																																									
123	Profinet Plug	Profinet failed to load the slots																																																																																																																																									
124	Invalid IM	Invalid Identification and Maintenance data																																																																																																																																									
125	CPM Watchdog	Profinet cyclic timeout error																																																																																																																																									
200	Software Fault	Software Fault																																																																																																																																									
201	BG Overrun	Background task overrun																																																																																																																																									
202	Firmware Invalid	Firmware is not compatible for the hardware version																																																																																																																																									
203	Drive Unknown	Unknown drive type																																																																																																																																									
204	DriveUnsupported	Unsupported drive type																																																																																																																																									
205	Mode Unknown	Unknown drive mode																																																																																																																																									
206	Mode Unsupported	Unsupported drive mode																																																																																																																																									
207	FLASH Error	Corrupted Non-volatile FLASH																																																																																																																																									
208	Database Init	Database initialization error																																																																																																																																									
209	File System Init	File system initialization error																																																																																																																																									
210	Mem Allocation	Memory allocation error																																																																																																																																									
211	Filesystem Error	File system error																																																																																																																																									
212	Config Save	Configuration file save error																																																																																																																																									
213	Over Temperature	Option module over temperature																																																																																																																																									
214	Drive Timeout	The drive has not responded within watchdog period																																																																																																																																									
215	eCMP Comms Error	eCMP communication failure																																																																																																																																									
216	TO eCMP Slot1	eCMP communication to slot 1 timeout																																																																																																																																									
217	TO eCMP Slot2	eCMP communication to slot 2 timeout																																																																																																																																									
228	EEPROM Error	EEPROM Initialisation error																																																																																																																																									

Trip	Diagnosis																						
<b>Slot3 HF</b>	<b>Ethernet interface in slot 3 hardware fault</b>																						
250	The <i>Slot3 HF</i> trip indicates that the Ethernet interface in slot 3 cannot operate. The reason for the error can be identified by the sub-trip number.																						
	<table border="1"> <thead> <tr> <th>Sub-trip</th> <th>Reason</th> </tr> </thead> <tbody> <tr> <td>1</td> <td>The module category cannot be identified</td> </tr> <tr> <td>2</td> <td>All the required customized menu table information has not been supplied or the tables supplied are corrupt</td> </tr> <tr> <td>3</td> <td>There is insufficient memory available to allocate the comms buffers for this module</td> </tr> <tr> <td>4</td> <td>The module has not indicated that it is running correctly during drive power-up</td> </tr> <tr> <td>5</td> <td>Module has been removed after power-up or it has stopped working</td> </tr> <tr> <td>6</td> <td>The module has not indicated that it has stopped accessing drive parameters during a drive mode change</td> </tr> <tr> <td>7</td> <td>The module has failed to acknowledge that a request has been made to reset the drive processor</td> </tr> <tr> <td>8</td> <td>The drive failed to correctly read the menu table from the module during drive power up</td> </tr> <tr> <td>9</td> <td>The drive failed to upload menu tables from the module and timed out (5 s)</td> </tr> <tr> <td>10</td> <td>Menu table CRC invalid</td> </tr> </tbody> </table>	Sub-trip	Reason	1	The module category cannot be identified	2	All the required customized menu table information has not been supplied or the tables supplied are corrupt	3	There is insufficient memory available to allocate the comms buffers for this module	4	The module has not indicated that it is running correctly during drive power-up	5	Module has been removed after power-up or it has stopped working	6	The module has not indicated that it has stopped accessing drive parameters during a drive mode change	7	The module has failed to acknowledge that a request has been made to reset the drive processor	8	The drive failed to correctly read the menu table from the module during drive power up	9	The drive failed to upload menu tables from the module and timed out (5 s)	10	Menu table CRC invalid
	Sub-trip	Reason																					
	1	The module category cannot be identified																					
	2	All the required customized menu table information has not been supplied or the tables supplied are corrupt																					
	3	There is insufficient memory available to allocate the comms buffers for this module																					
	4	The module has not indicated that it is running correctly during drive power-up																					
	5	Module has been removed after power-up or it has stopped working																					
	6	The module has not indicated that it has stopped accessing drive parameters during a drive mode change																					
	7	The module has failed to acknowledge that a request has been made to reset the drive processor																					
	8	The drive failed to correctly read the menu table from the module during drive power up																					
9	The drive failed to upload menu tables from the module and timed out (5 s)																						
10	Menu table CRC invalid																						
<b>Recommended actions:</b>																							
<ul style="list-style-type: none"> <li>Ensure the Ethernet interface is installed correctly</li> <li>Hardware fault - Contact the supplier of the drive.</li> </ul>																							
<b>Slot3 Not Fitted</b>	<b>Ethernet interface in slot 3 has been removed</b>																						
253	The <i>Slot3 Not Fitted</i> trip indicates that the Ethernet interface in slot 3 on the drive has been removed since the last power-up.																						
	<b>Recommended actions:</b> <ul style="list-style-type: none"> <li>Ensure the Ethernet interface is installed correctly</li> <li>Hardware fault - Contact the supplier of the drive.</li> </ul>																						
<b>Slot3 Watchdog</b>	<b>Ethernet interface watchdog service error</b>																						
251	The <i>Slot3 Watchdog</i> trip indicates that the Ethernet interface installed in slot 3 has started the option watchdog function and then failed to service the watchdog correctly.																						
	<b>Recommended actions:</b> <ul style="list-style-type: none"> <li>Hardware fault - Contact the supplier of the drive.</li> </ul>																						
<b>Slot App Menu</b>	<b>Application menu Customization conflict error</b>																						
216	The Slot App Menu trip indicates that more than one option slot has requested to customize the application menus 18, 19 and 20. The sub-trip number indicates which option slot has been allowed to customize the menus.																						
	<b>Recommended actions:</b> <ul style="list-style-type: none"> <li>Ensure that only one of the Application modules is configured to customize the application menus 18, 19 and 20</li> </ul>																						
<b>SlotX Different</b>	<b>Option module in option slot X has changed</b>																						
204 209 214	The <i>SlotX Different</i> trip indicates that the option module in option slot X on the drive is a different type to that installed when parameters were last saved on the drive. The sub-trip number gives the identification code of the module that was originally fitted. The reason for the trip can be identified by the sub-trip number.																						
	<table border="1"> <thead> <tr> <th>Sub-trip</th> <th>Reason</th> </tr> </thead> <tbody> <tr> <td>1</td> <td>No module was installed previously</td> </tr> <tr> <td>2</td> <td>A module with the same identifier is installed, but the set-up menu for this option slot has been changed, and so default parameters have been loaded for this menu.</td> </tr> <tr> <td>3</td> <td>A module with the same identifier is installed, but the applications menu for this option slot has been changed, and so default parameters have been loaded for this menu.</td> </tr> <tr> <td>4</td> <td>A module with the same identifier is installed, but the set-up and applications menu for this option slot have been changed, and so default parameters have been loaded for these menus.</td> </tr> <tr> <td>&gt;99</td> <td>Shows the identifier of the module previously installed.</td> </tr> </tbody> </table>	Sub-trip	Reason	1	No module was installed previously	2	A module with the same identifier is installed, but the set-up menu for this option slot has been changed, and so default parameters have been loaded for this menu.	3	A module with the same identifier is installed, but the applications menu for this option slot has been changed, and so default parameters have been loaded for this menu.	4	A module with the same identifier is installed, but the set-up and applications menu for this option slot have been changed, and so default parameters have been loaded for these menus.	>99	Shows the identifier of the module previously installed.										
	Sub-trip	Reason																					
	1	No module was installed previously																					
	2	A module with the same identifier is installed, but the set-up menu for this option slot has been changed, and so default parameters have been loaded for this menu.																					
	3	A module with the same identifier is installed, but the applications menu for this option slot has been changed, and so default parameters have been loaded for this menu.																					
4	A module with the same identifier is installed, but the set-up and applications menu for this option slot have been changed, and so default parameters have been loaded for these menus.																						
>99	Shows the identifier of the module previously installed.																						
<b>Recommended actions:</b>																							
<ul style="list-style-type: none"> <li>Turn off the power, ensure the correct option modules are installed in the correct option slots and re-apply the power.</li> <li>Confirm that the currently installed option module is correct, ensure option module parameters are set correctly and perform a user save in Pr <b>mm.000</b>.</li> </ul>																							

Trip	Diagnosis																						
<b>SlotX Error</b>	<b>Option module in option slot X has detected a fault</b>																						
202 207 212	<p>The <i>SlotX Error</i> trip indicates that the option module in option slot X on the drive has detected an error. The reason for the error can be identified by the sub-trip number.</p> <p><b>Recommended actions:</b></p> <ul style="list-style-type: none"> <li>See the relevant <i>Option Module User Guide</i> for details of the trip</li> </ul>																						
<b>SlotX HF</b>	<b>Option module X hardware fault</b>																						
200 205 210	<p>The <i>SlotX HF</i> trip indicates that the option module in option slot X cannot operate. The possible causes of the trip can be identified by the sub-trip number.</p> <table border="1"> <thead> <tr> <th>Sub-trip</th> <th>Reason</th> </tr> </thead> <tbody> <tr> <td>1</td> <td>The module category cannot be identified</td> </tr> <tr> <td>2</td> <td>All the required customized menu table information has not been supplied or the tables supplied are corrupt</td> </tr> <tr> <td>3</td> <td>There is insufficient memory available to allocate the comms buffers for this module</td> </tr> <tr> <td>4</td> <td>The module has not indicated that it is running correctly during drive power-up</td> </tr> <tr> <td>5</td> <td>Module has been removed after power-up or it has stopped working</td> </tr> <tr> <td>6</td> <td>The module has not indicated that it has stopped accessing drive parameters during a drive mode change</td> </tr> <tr> <td>7</td> <td>The module has failed to acknowledge that a request has been made to reset the drive processor</td> </tr> <tr> <td>8</td> <td>The drive failed to correctly read the menu table from the module during drive power up</td> </tr> <tr> <td>9</td> <td>The drive failed to upload menu tables from the module and timed out (5 s)</td> </tr> <tr> <td>10</td> <td>Menu table CRC invalid</td> </tr> </tbody> </table> <p><b>Recommended actions:</b></p> <ul style="list-style-type: none"> <li>Ensure the option module is installed correctly</li> <li>Replace the option module</li> <li>Replace the drive</li> </ul>	Sub-trip	Reason	1	The module category cannot be identified	2	All the required customized menu table information has not been supplied or the tables supplied are corrupt	3	There is insufficient memory available to allocate the comms buffers for this module	4	The module has not indicated that it is running correctly during drive power-up	5	Module has been removed after power-up or it has stopped working	6	The module has not indicated that it has stopped accessing drive parameters during a drive mode change	7	The module has failed to acknowledge that a request has been made to reset the drive processor	8	The drive failed to correctly read the menu table from the module during drive power up	9	The drive failed to upload menu tables from the module and timed out (5 s)	10	Menu table CRC invalid
Sub-trip	Reason																						
1	The module category cannot be identified																						
2	All the required customized menu table information has not been supplied or the tables supplied are corrupt																						
3	There is insufficient memory available to allocate the comms buffers for this module																						
4	The module has not indicated that it is running correctly during drive power-up																						
5	Module has been removed after power-up or it has stopped working																						
6	The module has not indicated that it has stopped accessing drive parameters during a drive mode change																						
7	The module has failed to acknowledge that a request has been made to reset the drive processor																						
8	The drive failed to correctly read the menu table from the module during drive power up																						
9	The drive failed to upload menu tables from the module and timed out (5 s)																						
10	Menu table CRC invalid																						
<b>SlotX Not Fitted</b>	<b>Option module in option slot X has been removed</b>																						
203 208 213	<p>The <i>SlotX Not Fitted</i> trip indicates that the option module in option slot X on the drive has been removed since the last power up.</p> <p><b>Recommended actions:</b></p> <ul style="list-style-type: none"> <li>Ensure the option module is installed correctly.</li> <li>Re-install the option module.</li> <li>To confirm that the removed option module is no longer required perform a save function in Pr <b>mm.000</b>.</li> </ul>																						
<b>SlotX Watchdog</b>	<b>Option module watchdog function service error</b>																						
201 206 211	<p>The <i>SlotX Watchdog</i> trip indicates that the option module installed in Slot X has started the option watchdog function and then failed to service the watchdog correctly.</p> <p><b>Recommended actions:</b></p> <ul style="list-style-type: none"> <li>Replace the option module</li> </ul>																						
<b>Soft Start</b>	<b>Soft start relay failed to close, soft start monitor failed</b>																						
226	<p>The <i>Soft Start</i> trip indicates that the soft start relay in the drive failed to close or the soft start monitoring circuit has failed.</p> <p><b>Recommended actions:</b></p> <ul style="list-style-type: none"> <li>Hardware fault – Contact the supplier of the drive</li> </ul>																						
<b>Stored HF</b>	<b>Hardware trip has occurred during last power down</b>																						
221	<p>The <i>Stored HF</i> trip indicates that a hardware trip (HF01 –HF20) has occurred and the drive has been power cycled. The sub-trip number identifies the HF trip i.e. stored HF.17.</p> <p><b>Recommended actions:</b></p> <ul style="list-style-type: none"> <li>Enter 1299 in Pr <b>mm.000</b> and press reset to clear the trip</li> </ul>																						

Trip	Diagnosis																																																								
<b>Sub-array RAM</b>	<b>RAM allocation error</b>																																																								
227	<p>The Sub-array RAM indicates that an option module, derivative image or user program image has requested more parameter RAM than is allowed. The RAM allocation is checked in order of resulting sub-trip numbers, and so the failure with the highest sub-trip number is given. The sub-trip is calculated as (parameter size) + (parameter type) + sub-array number.</p> <table border="1"> <thead> <tr> <th>Parameter size</th> <th>Value</th> </tr> </thead> <tbody> <tr> <td>1 bit</td> <td>1000</td> </tr> <tr> <td>8 bit</td> <td>2000</td> </tr> <tr> <td>16 bit</td> <td>3000</td> </tr> <tr> <td>32 bit</td> <td>4000</td> </tr> <tr> <td>64 bit</td> <td>5000</td> </tr> </tbody> </table> <table border="1"> <thead> <tr> <th>Parameter type</th> <th>Value</th> </tr> </thead> <tbody> <tr> <td>Volatile</td> <td>0</td> </tr> <tr> <td>User save</td> <td>100</td> </tr> <tr> <td>Power-down save</td> <td>200</td> </tr> </tbody> </table> <table border="1"> <thead> <tr> <th>Sub-array</th> <th>Menus</th> <th>Value</th> </tr> </thead> <tbody> <tr> <td>Applications menus</td> <td>18-20</td> <td>1</td> </tr> <tr> <td>Derivative image</td> <td>29</td> <td>2</td> </tr> <tr> <td>User program image</td> <td>30</td> <td>3</td> </tr> <tr> <td>Option slot 1 set-up</td> <td>15</td> <td>4</td> </tr> <tr> <td>Option slot 1 applications</td> <td>25</td> <td>5</td> </tr> <tr> <td>Option slot 2 set-up</td> <td>16</td> <td>6</td> </tr> <tr> <td>Option slot 2 applications</td> <td>26</td> <td>7</td> </tr> <tr> <td>Option slot 3 set-up</td> <td>17</td> <td>8</td> </tr> <tr> <td>Option slot 3 applications</td> <td>27</td> <td>9</td> </tr> <tr> <td>Option slot 4 set-up</td> <td>24</td> <td>10</td> </tr> <tr> <td>Option slot 4 applications</td> <td>28</td> <td>11</td> </tr> </tbody> </table>	Parameter size	Value	1 bit	1000	8 bit	2000	16 bit	3000	32 bit	4000	64 bit	5000	Parameter type	Value	Volatile	0	User save	100	Power-down save	200	Sub-array	Menus	Value	Applications menus	18-20	1	Derivative image	29	2	User program image	30	3	Option slot 1 set-up	15	4	Option slot 1 applications	25	5	Option slot 2 set-up	16	6	Option slot 2 applications	26	7	Option slot 3 set-up	17	8	Option slot 3 applications	27	9	Option slot 4 set-up	24	10	Option slot 4 applications	28	11
Parameter size	Value																																																								
1 bit	1000																																																								
8 bit	2000																																																								
16 bit	3000																																																								
32 bit	4000																																																								
64 bit	5000																																																								
Parameter type	Value																																																								
Volatile	0																																																								
User save	100																																																								
Power-down save	200																																																								
Sub-array	Menus	Value																																																							
Applications menus	18-20	1																																																							
Derivative image	29	2																																																							
User program image	30	3																																																							
Option slot 1 set-up	15	4																																																							
Option slot 1 applications	25	5																																																							
Option slot 2 set-up	16	6																																																							
Option slot 2 applications	26	7																																																							
Option slot 3 set-up	17	8																																																							
Option slot 3 applications	27	9																																																							
Option slot 4 set-up	24	10																																																							
Option slot 4 applications	28	11																																																							
<b>Temp Feedback</b>	<b>Internal thermistor has failed</b>																																																								
218	<p>The <i>Temp Feedback</i> trip indicates that an internal thermistor has failed. The thermistor location can be identified by the sub-trip number.</p> <table border="1"> <thead> <tr> <th>Source</th> <th>xx</th> <th>y</th> <th>zz</th> </tr> </thead> <tbody> <tr> <td>Control PCB</td> <td>00</td> <td>0</td> <td>01: Control PCB thermistor 1 02: Control PCB thermistor 2 03: Compact brake resistor thermistor</td> </tr> <tr> <td>Power system</td> <td>Power module number</td> <td>0</td> <td>00: Temperature feedback provided via power system comms.</td> </tr> <tr> <td>Power system</td> <td>01</td> <td>Rectifier number*</td> <td>Always zero</td> </tr> </tbody> </table> <p>* For a parallel power-module system the rectifier number will be zero as it is not possible to determine which rectifier has detected the fault.</p> <p><b>Recommended actions:</b></p> <ul style="list-style-type: none"> <li>Hardware fault – Contact the supplier of the drive</li> </ul>	Source	xx	y	zz	Control PCB	00	0	01: Control PCB thermistor 1 02: Control PCB thermistor 2 03: Compact brake resistor thermistor	Power system	Power module number	0	00: Temperature feedback provided via power system comms.	Power system	01	Rectifier number*	Always zero																																								
Source	xx	y	zz																																																						
Control PCB	00	0	01: Control PCB thermistor 1 02: Control PCB thermistor 2 03: Compact brake resistor thermistor																																																						
Power system	Power module number	0	00: Temperature feedback provided via power system comms.																																																						
Power system	01	Rectifier number*	Always zero																																																						
<b>Th Brake Res</b>	<b>Brake resistor over temperature</b>																																																								
10	<p>The <i>Th Brake Res</i> is initiated, If hardware based braking resistor thermal monitoring is connected and the resistor overheats. If the braking resistor is not used then this trip must be disabled with bit 3 of Action <i>On Trip Detection</i> (10.037) to prevent this trip.</p> <p><b>Recommended actions:</b></p> <ul style="list-style-type: none"> <li>Check brake resistor wiring</li> <li>Check braking resistor value is greater than or equal to the minimum resistance value</li> <li>Check braking resistor insulation</li> </ul>																																																								
<b>Th Short Circuit</b>	<b>Motor thermistor short circuit</b>																																																								
25	<p>The <i>Th Short Circuit</i> trip indicates that the motor thermistor connected to the drive is short circuit or low impedance i.e. &lt; 50 Ω. The location of the trip can be identified by the sub-trip number.</p> <table border="1"> <thead> <tr> <th>Sub-trip</th> <th>Source</th> </tr> </thead> <tbody> <tr> <td>4</td> <td>Position feedback interface</td> </tr> </tbody> </table> <p><b>Recommended actions:</b></p> <ul style="list-style-type: none"> <li>Check thermistor continuity</li> <li>Replace motor / motor thermistor</li> </ul>	Sub-trip	Source	4	Position feedback interface																																																				
Sub-trip	Source																																																								
4	Position feedback interface																																																								

Trip	Diagnosis				
<b>Thermistor</b>	<b>Motor thermistor over-temperature</b>				
24	The <i>Thermistor</i> trip indicates that the motor thermistor connected to the drive has indicated a motor over temperature. The location of the trip can be identified by the sub-trip number.				
	<table border="1" style="width: 100%;"> <thead> <tr> <th style="text-align: center;">Sub-trip</th> <th style="text-align: center;">Source</th> </tr> </thead> <tbody> <tr> <td style="text-align: center;">4</td> <td>Position feedback interface</td> </tr> </tbody> </table>	Sub-trip	Source	4	Position feedback interface
	Sub-trip	Source			
4	Position feedback interface				
<p><b>Recommended actions:</b></p> <ul style="list-style-type: none"> <li>• Check motor temperature</li> <li>• Check <i>Threshold Level</i> (07.048)</li> <li>• Check thermistor continuity</li> </ul>					
<b>Undefined</b>	<b>Drive has tripped and the cause of the trip is Undefined</b>				
110	The <i>Undefined</i> trip indicates that the power system has generated but did not identify the trip from the power system. The cause of the trip is unknown.				
	<p><b>Recommended actions:</b></p> <ul style="list-style-type: none"> <li>• Hardware fault – return the drive to the supplier</li> </ul>				

Trip	Diagnosis																																																																																																	
<b>User Program</b>	<b>On board user program error</b>																																																																																																	
	The <i>User Program</i> trip indicates that an error has been detected in the onboard user program image. The reason for the trip can be identified by the sub-trip number.																																																																																																	
	<table border="1"> <thead> <tr> <th>Sub-trip</th> <th>Reason</th> <th>Comments</th> </tr> </thead> <tbody> <tr> <td>1</td> <td>Divide by zero</td> <td></td> </tr> <tr> <td>2</td> <td>Undefined trip</td> <td></td> </tr> <tr> <td>3</td> <td>Attempted fast parameter access set-up with non-existent parameter</td> <td></td> </tr> <tr> <td>4</td> <td>Attempted access to non-existent parameter</td> <td></td> </tr> <tr> <td>5</td> <td>Attempted write to read-only parameter</td> <td></td> </tr> <tr> <td>6</td> <td>Attempted an over-range write</td> <td></td> </tr> <tr> <td>7</td> <td>Attempted read from write-only parameter</td> <td></td> </tr> <tr> <td>30</td> <td>The image has failed because either its CRC is incorrect, or there are less than 6 bytes in the image or the image header version is less than 5.</td> <td>Occurs when the drive powers-up or the image is programmed. The image tasks will not run</td> </tr> <tr> <td>31</td> <td>The image requires more RAM for heap and stack than can be provided by the drive.</td> <td>As 30</td> </tr> <tr> <td>32</td> <td>The image requires an OS function call that is higher than the maximum allowed</td> <td>As 30</td> </tr> <tr> <td>33</td> <td>The ID code within the image is not valid</td> <td>As 30</td> </tr> <tr> <td>40</td> <td>The timed task has not completed in time and has been suspended</td> <td><i>Onboard User Program: Enable</i> (11.047) is reset to zero when the trip is initiated</td> </tr> <tr> <td>41</td> <td>Undefined function called, i.e. a function in the host system vector table that has not been assigned.</td> <td>As 40</td> </tr> <tr> <td>52</td> <td>Customized menu table CRC check failed</td> <td>As 30</td> </tr> <tr> <td>53</td> <td>Customized menu table changed</td> <td>Occurs when the drive powers-up or the image is programmed and the table has changed. Defaults are loaded for the user program menu and the trip will keep occurring until drive parameters are saved.</td> </tr> <tr> <td>80</td> <td>Image is not compatible with the control board</td> <td>Initiated from within the image code</td> </tr> <tr> <td>81</td> <td>Image is not compatible with the control board serial number</td> <td>As 80</td> </tr> <tr> <td>100</td> <td>Image has detected and prevented attempted pointer access outside of the IEC task's heap area.</td> <td></td> </tr> <tr> <td>101</td> <td>Image has detected and prevented misaligned pointer usage.</td> <td></td> </tr> <tr> <td>102</td> <td>Image has detected an array bounds violation and prevented its access.</td> <td></td> </tr> <tr> <td>103</td> <td>Image has attempted to convert a data type to or from an unknown data type, has failed and has shut itself down.</td> <td></td> </tr> <tr> <td>104</td> <td>Image has attempted to use an unknown user service function.</td> <td></td> </tr> <tr> <td>200</td> <td>User program has invoked a "divide" service with a denominator of zero. (Note that this is raised by the downloaded image and has therefore been given a distinct error code despite being the same fundamental problem as sub-trip 1.)</td> <td></td> </tr> <tr> <td>201</td> <td>Parameter access is not supported. An attempt to read database other than the host drive.</td> <td></td> </tr> <tr> <td>202</td> <td>Parameter does not exist. Database was host drive but the specified parameter does not exist.</td> <td></td> </tr> <tr> <td>203</td> <td>Parameter is read-only.</td> <td></td> </tr> <tr> <td>204</td> <td>Parameter is write-only.</td> <td></td> </tr> <tr> <td>205</td> <td>Unknown parameter error.</td> <td></td> </tr> <tr> <td>206</td> <td>Invalid bit present in parameter. The parameter does not contain the specified bit.</td> <td></td> </tr> <tr> <td>207</td> <td>Parameter format lookup failed. Failed to get parameter information data.</td> <td></td> </tr> <tr> <td>208</td> <td>An over-range write has been attempted.</td> <td></td> </tr> </tbody> </table>	Sub-trip	Reason	Comments	1	Divide by zero		2	Undefined trip		3	Attempted fast parameter access set-up with non-existent parameter		4	Attempted access to non-existent parameter		5	Attempted write to read-only parameter		6	Attempted an over-range write		7	Attempted read from write-only parameter		30	The image has failed because either its CRC is incorrect, or there are less than 6 bytes in the image or the image header version is less than 5.	Occurs when the drive powers-up or the image is programmed. The image tasks will not run	31	The image requires more RAM for heap and stack than can be provided by the drive.	As 30	32	The image requires an OS function call that is higher than the maximum allowed	As 30	33	The ID code within the image is not valid	As 30	40	The timed task has not completed in time and has been suspended	<i>Onboard User Program: Enable</i> (11.047) is reset to zero when the trip is initiated	41	Undefined function called, i.e. a function in the host system vector table that has not been assigned.	As 40	52	Customized menu table CRC check failed	As 30	53	Customized menu table changed	Occurs when the drive powers-up or the image is programmed and the table has changed. Defaults are loaded for the user program menu and the trip will keep occurring until drive parameters are saved.	80	Image is not compatible with the control board	Initiated from within the image code	81	Image is not compatible with the control board serial number	As 80	100	Image has detected and prevented attempted pointer access outside of the IEC task's heap area.		101	Image has detected and prevented misaligned pointer usage.		102	Image has detected an array bounds violation and prevented its access.		103	Image has attempted to convert a data type to or from an unknown data type, has failed and has shut itself down.		104	Image has attempted to use an unknown user service function.		200	User program has invoked a "divide" service with a denominator of zero. (Note that this is raised by the downloaded image and has therefore been given a distinct error code despite being the same fundamental problem as sub-trip 1.)		201	Parameter access is not supported. An attempt to read database other than the host drive.		202	Parameter does not exist. Database was host drive but the specified parameter does not exist.		203	Parameter is read-only.		204	Parameter is write-only.		205	Unknown parameter error.		206	Invalid bit present in parameter. The parameter does not contain the specified bit.		207	Parameter format lookup failed. Failed to get parameter information data.		208	An over-range write has been attempted.		
Sub-trip	Reason	Comments																																																																																																
1	Divide by zero																																																																																																	
2	Undefined trip																																																																																																	
3	Attempted fast parameter access set-up with non-existent parameter																																																																																																	
4	Attempted access to non-existent parameter																																																																																																	
5	Attempted write to read-only parameter																																																																																																	
6	Attempted an over-range write																																																																																																	
7	Attempted read from write-only parameter																																																																																																	
30	The image has failed because either its CRC is incorrect, or there are less than 6 bytes in the image or the image header version is less than 5.	Occurs when the drive powers-up or the image is programmed. The image tasks will not run																																																																																																
31	The image requires more RAM for heap and stack than can be provided by the drive.	As 30																																																																																																
32	The image requires an OS function call that is higher than the maximum allowed	As 30																																																																																																
33	The ID code within the image is not valid	As 30																																																																																																
40	The timed task has not completed in time and has been suspended	<i>Onboard User Program: Enable</i> (11.047) is reset to zero when the trip is initiated																																																																																																
41	Undefined function called, i.e. a function in the host system vector table that has not been assigned.	As 40																																																																																																
52	Customized menu table CRC check failed	As 30																																																																																																
53	Customized menu table changed	Occurs when the drive powers-up or the image is programmed and the table has changed. Defaults are loaded for the user program menu and the trip will keep occurring until drive parameters are saved.																																																																																																
80	Image is not compatible with the control board	Initiated from within the image code																																																																																																
81	Image is not compatible with the control board serial number	As 80																																																																																																
100	Image has detected and prevented attempted pointer access outside of the IEC task's heap area.																																																																																																	
101	Image has detected and prevented misaligned pointer usage.																																																																																																	
102	Image has detected an array bounds violation and prevented its access.																																																																																																	
103	Image has attempted to convert a data type to or from an unknown data type, has failed and has shut itself down.																																																																																																	
104	Image has attempted to use an unknown user service function.																																																																																																	
200	User program has invoked a "divide" service with a denominator of zero. (Note that this is raised by the downloaded image and has therefore been given a distinct error code despite being the same fundamental problem as sub-trip 1.)																																																																																																	
201	Parameter access is not supported. An attempt to read database other than the host drive.																																																																																																	
202	Parameter does not exist. Database was host drive but the specified parameter does not exist.																																																																																																	
203	Parameter is read-only.																																																																																																	
204	Parameter is write-only.																																																																																																	
205	Unknown parameter error.																																																																																																	
206	Invalid bit present in parameter. The parameter does not contain the specified bit.																																																																																																	
207	Parameter format lookup failed. Failed to get parameter information data.																																																																																																	
208	An over-range write has been attempted.																																																																																																	
249																																																																																																		

Trip	Diagnosis
<b>User Prog Trip</b>	<b>Trip generated by an onboard user program</b>
<b>96</b>	This trip can be initiated from within an onboard user program using a function call which defines the sub-trip number. <b>Recommended actions:</b> <ul style="list-style-type: none"> <li>• Check the user program</li> </ul>
<b>User Save</b>	<b>User Save error / not completed</b>
<b>36</b>	The <i>User Save</i> trip indicates that an error has been detected in the user save parameters saved in non-volatile memory. For example, following a user save command, if the power to the drive was removed when the user parameters were being saved. <b>Recommended actions:</b> <ul style="list-style-type: none"> <li>• Perform a user save in Pr <b>mm.000</b> to ensure that the trip doesn't occur the next time the drive is powered up.</li> <li>• Ensure that the drive has enough time to complete the save before removing the power to the drive.</li> </ul>
<b>User Trip</b>	<b>User generated trip</b>
<b>40 -89 112 -159</b>	These trips are not generated by the drive and are to be used by the user to trip the drive through an application program. <b>Recommended actions:</b> <ul style="list-style-type: none"> <li>• Check the user program</li> </ul>
<b>Voltage Range</b>	<b>Supply voltage out of range detected in Regen mode</b>
<b>169</b>	The <i>Voltage Range</i> trip is initiated, if the Regen <i>Minimum Voltage</i> (03.026) is set to a non-zero value and the supply voltage is outside the range defined by <i>Regen Maximum Voltage</i> (03.027) and <i>Regen Minimum Voltage</i> (03.026) for more than 100 ms. <b>Recommended actions:</b> <ul style="list-style-type: none"> <li>• Ensure the supply voltage is operating within the drive specification.</li> <li>• Ensure Pr <b>03.026</b> and Pr <b>03.027</b> are set correctly</li> <li>• Check the supply voltage waveform using an oscilloscope</li> <li>• Reduce the level of supply disturbance</li> <li>• Set <i>Maximum Voltage</i> (03.027) to zero to disable the trip.</li> </ul>
<b>Watchdog</b>	<b>Control word watchdog has timed out</b>
<b>30</b>	The <i>Watchdog</i> trip indicates that the control word has been enabled and has timed out. <b>Recommended actions:</b> <p>Once Pr <b>06.042</b> bit 14 has been changed from 0 to 1 to enable the watchdog, this must be repeated every 1 s or a Watchdog trip will be initiated. The watchdog is disabled when the trip occurs and must be re-enabled if required when the trip is reset.</p>

**Table 13-5 Serial communications look up table**

No	Trip	No	Trip	No	Trip
1	Reserved 001	93	Inductor Too Hot	192	Encoder 4
2	Over Volts	94	Rectifier Set-up	193	Encoder 5
3	OI ac	95	Reserved 95	194	Encoder 6
4	OI Brake	96	User Prog Trip	195	Encoder 7
5	PSU	97	Data Changing	196	Encoder 8
6	External Trip	98	Out Phase Loss	197	Encoder 9
7	Over Speed	99	CAM	198	Phasing Error
8	Inductance	100	Reset	199	Destination
9	PSU 24V	101	OHT Brake	200	Slot1 HF
10	Th Brake Res	102	Cloning	201	Slot1 Watchdog
11	Autotune 1	103	Inter-connect	202	Slot1 Error
12	Autotune 2	104 - 108	Reserved 104 - 108	203	Slot1 Not Fitted
13	Autotune 3	109	OI dc	204	Slot1 Different
14	Autotune 4	110	Undefined	205	Slot2 HF
15	Autotune 5	111	Configuration	206	Slot2 Watchdog
16	Autotune 6	112 - 159	User Trip 112 - 159	207	Slot2 Error
17	Autotune 7	160	Island	208	Slot2 Not Fitted
18	Autotune Stopped	161	Reserved 161	209	Slot2 Different
19	Brake R Too Hot	162	Encoder 12	210	Slot3 HF
20	Motor Too Hot	163	Encoder 13	211	Slot3 Watchdog
21	OHT Inverter	164	Encoder 14	212	Slot3 Error
22	OHT Power	165 - 168	Reserved 165 - 168	213	Slot3 Not Fitted
23	OHT Control	169	Voltage Range	214	Slot3 Different
24	Thermistor	170 - 173	Reserved 170 - 173	215	Option Disable
25	Th Short Circuit	174	Card Slot	216	Slot App Menu
26	I/O Overload	175	Card Product	217	App Menu Changed
27	OHT dc bus	176	Name Plate	218	Temp Feedback
28	An Input Loss 1	177	Card Boot	220	Power Data
30	Watchdog	178	Card Busy	221	Stored HF
31	EEPROM Fail	179	Card Data Exists	222	Reserved 222
32	Phase Loss	180	Card Option	223	Rating Mismatch
33	Resistance	181	Card Read Only	224	Drive Size
34	Keypad Mode	182	Card Error	225	Current Offset
35	Control Word	183	Card No Data	226	Soft Start
36	User Save	184	Card Full	227	Sub-array RAM
37	Power Down Save	185	Card Access	228 - 246	Reserved 228 - 246
38	Low Load	186	Card Rating	247	Derivative ID
39	Line Sync	187	Card Drive Mode	248	Derivative Image
40 -89	User Trip 40 - 89	188	Card Compare	249	User Program
90	Power Comms	189	Encoder 1	255	Reset Logs
91	User 24V	190	Encoder 2		
92	OI Snubber	191	Encoder 3	255	Reset Logs

The trips can be grouped into the following categories. It should be noted that a trip can only occur when the drive is not tripped or is already tripped but with a trip with a lower priority number.

**Table 13-6 Trip categories**

Priority	Category	Trips	Comments
1	Internal faults	HFxx	These indicate internal problems and cannot be reset. All drive features are inactive after any of these trips occur. If an KI-Keypad is installed it will show the trip, but the keypad will not function.
1	Stored HF trip	{Stored HF}	This trip cannot be cleared unless 1299 is entered into <i>Parameter (mm.000)</i> and a reset is initiated.
2	Non-resettable trips	Trip numbers 218 to 247, {Slot1 HF}, {Slot2 HF}, {Slot3 HF} or {Slot4 HF}	These trips cannot be reset.
3	Volatile memory failure	{EEPROM Fail}	This can only be reset if Parameter <b>mm.000</b> is set to 1233 or 1244, or if <i>Load Defaults</i> (11.043) is set to a non-zero value.
4	SD Card trips	Trip numbers 174, 175 and 177 to 188	These trips are priority 5 during power-up.
4	Internal 24V and position feedback interface power supply	{PSU 24V} and {Encoder 1}	These trips can override {Encoder 2} to {Encoder 6} trips.
5	Trips with extended reset times	{OI ac}, {OI Brake}, and OI dc}	These trips cannot be reset until 10 s after the trip was initiated.
5	Phase loss and d.c. link power circuit protection	{Phase Loss} and {Oht dc bus}	The drive will attempt to stop the motor before tripping if a {Phase Loss}.000 trip occurs unless this feature has been disabled (see <i>Action On Trip Detection</i> (10.037)). The drive will always attempt to stop the motor before tripping if an {Oht dc bus} occurs.
5	Standard trips	All other trips	

### 13.5 Internal / Hardware trips

Trips {HF01} to {HF25} are internal faults that do not have trip numbers. If one of these trips occurs, the main drive processor has detected an irrecoverable error. All drive functions are stopped and the trip message will be displayed on the drive keypad. If a non permanent trip occurs this may be reset by power cycling the drive. On power up after it has been power cycled the drive will trip on Stored HF. The sub-trip code is the number of the original HF trip. Enter 1299 in **mm.000** to clear the Stored HF trip.

## 13.6 Alarm indications

In any mode, an alarm is an indication given on the KI-Remote Keypad display by alternating the alarm string with the drive status string on the first row and showing the alarm symbol in the last character in the first row. If an action is not taken to eliminate any alarm except "Auto Tune and Limit Switch" the drive may eventually trip. Alarms are not displayed when a parameter is being edited, but the user will still see the alarm character on the upper row.

**Table 13-7 Alarm indications**

Alarm string	Description
<b>Brake Resistor</b>	Brake resistor overload. <i>Braking Resistor Thermal Accumulator</i> (10.039) in the drive has reached 75.0 % of the value at which the drive will trip.
<b>Motor Overload</b>	<i>Motor Protection Accumulator</i> (04.019) in the drive has reached 75.0 % of the value at which the drive will trip and the load on the drive is > 100 %.
<b>Ind Overload</b>	Regen inductor overload. <i>Inductor Protection Accumulator</i> (04.019) in the drive has reached 75.0 % of the value at which the drive will trip and the load on the drive is > 100 %.
<b>Drive Overload</b>	Drive over temperature. <i>Percentage Of Drive Thermal Trip Level</i> (07.036) in the drive is greater than 90 %.
<b>Auto Tune</b>	The autotune procedure has been initialized and an autotune in progress.
<b>Limit Switch</b>	Limit switch active. Indicates that a limit switch is active and that is causing the motor to be stopped.

## 13.7 Status indications

**Table 13-8 Status indications**

Upper row string	Description	Drive output stage
<b>Inhibit</b>	The drive is inhibited and cannot be run. The Safe Torque Off signal is not applied to Safe Torque Off terminals or Pr <b>06.015</b> is set to 0.	Disabled
<b>Ready</b>	The drive is ready to run. The drive enable is active, but the drive inverter is not active because the final drive run is not active.	Disabled
<b>Stop</b>	The drive is stopped / holding zero speed.	Enabled
<b>Run</b>	The drive is active and running.	Enabled
<b>Scan</b>	The drive is enabled in Regen mode and is trying to synchronize to the supply.	Enabled
<b>Supply Loss</b>	Supply loss condition has been detected.	Enabled
<b>Deceleration</b>	The motor is being decelerated to zero speed / frequency because the final drive run has been deactivated.	Enabled
<b>dc injection</b>	The drive is applying dc injection braking.	Enabled
<b>Position</b>	Positioning / position control is active during an orientation stop.	Enabled
<b>Trip</b>	The drive has tripped and no longer controlling the motor. The trip code appears in the lower display.	Disabled
<b>Active</b>	The regen unit is enabled and synchronized to the supply.	Enabled
<b>Under Voltage</b>	The drive is in the under voltage state either in low voltage or high voltage mode.	Disabled
<b>Heat</b>	The motor pre-heat function is active.	Enabled
<b>Phasing</b>	The drive is performing a 'phasing test on enable'.	Enabled

**Table 13-9 Option module and SD Card and other status indications at power-up**

First row string	Second row string	Status
<b>Booting</b>	<b>Parameters</b>	Parameters are being loaded
Drive parameters are being loaded from an SD Card		
<b>Booting</b>	<b>User Program</b>	User program being loaded
User program is being loaded from an SD Card to the drive		
<b>Booting</b>	<b>Option Program</b>	User program being loaded
User program is being loaded from an SD Card to the option module in slot X		
<b>Writing To</b>	<b>NV Card</b>	Data being written to SD Card
Data is being written to an SD Card to ensure that its copy of the drive parameters is correct because the drive is in Auto or Boot mode		
<b>Waiting For</b>	<b>Power System</b>	Waiting for power stage
The drive is waiting for the processor in the power stage to respond after power-up		
<b>Waiting For</b>	<b>Options</b>	Waiting for an option module
The drive is waiting for the Options Modules to respond after power-up		
<b>Uploading From</b>	<b>Options</b>	Loading parameter database
At power-up it may be necessary to update the parameter database held by the drive because an option module has changed or because an applications module has requested changes to the parameter structure. This may involve data transfer between the drive and option modules. During this period 'Uploading From Options' is displayed		

## 13.8 Programming error indications

Following are the error message displayed on the drive keypad when an error occurs during programming of drive firmware.

**Table 13-10 Programming error indications**

Error String	Reason	Solution
<b>Error 1</b>	There is not enough drive memory requested by all the option modules.	Power down drive and remove some of the option modules until the message disappears.
<b>Error 2</b>	At least one option module did not acknowledge the reset request.	Power cycle drive.
<b>Error 3</b>	The boot loader failed to erase the processor flash.	Power cycle drive and try again. If problem persists, return drive.
<b>Error 4</b>	The boot loader failed to program the processor flash.	Power cycle drive and try again. If problem persists, return drive.
<b>Error 5</b>	One option module did not initialize correctly. Option module did not set Ready to Run flag.	Remove faulty option module.

## 13.9 Displaying the trip history

The drive retains a log of the last ten trips that have occurred. *Trip 0* (10.020) to *Trip 9* (10.029) store the most recent 10 trips that have occurred where *Trip 0* (10.020) is the most recent and *Trip 9* (10.029) is the oldest. When a new trip occurs it is written to *Trip 0* (10.020) and all the other trips move down the log, with oldest being lost. The date and time when each trip occurs are also stored in the date and time log, i.e. *Trip 0 Date* (10.041) to *Trip 9 Time* (10.060). The date and time are taken from *Date* (06.016) and *Time* (06.017). Some trips have sub-trip numbers which give more detail about the reason for the trip. If a trip has a sub-trip number its value is stored in the sub-trip log, i.e. *Trip 0 Sub-trip Number* (10.070) to *Trip 9 Sub-trip Number* (10.079). If the trip does not have a sub-trip number then zero is stored in the sub-trip log.

If any parameter between Pr **10.020** and Pr **10.029** inclusive is read by serial communication, then the trip number in Table 13-5 is the value transmitted.

### NOTE

The trip logs can be reset by writing a value of 255 in Pr **10.038**.

## 13.10 Behaviour of the drive when tripped

If the drive trips, the output of the drive is disabled so the load coasts to a stop. If any trip occurs the following read only parameters are frozen until the trip is cleared. This is to help in diagnose the cause of the trip.

Parameter	Description
01.001	Frequency / speed reference
01.002	Pre-skip filter reference
01.003	Pre-ramp reference
02.001	Post-ramp reference
03.001	Frequency slaving demand / Final speed ref
03.002	Speed feedback
03.003	Speed error
03.004	Speed controller output
04.001	Current magnitude
04.002	Active current
04.017	Reactive current
05.001	Output frequency
05.002	Output voltage
05.003	Power
05.005	DC bus voltage
07.001	Analog input 1

If the parameters are not required to be frozen then this can be disabled by setting bit 4 of Pr **10.037**.

## 14 UL listing information

This section is intended to be used in conjunction with the *Digitax HD M75X Series Installation and Technical Guide*.

### 14.1 Scope

All models are cUL Listed to Canadian and US requirements. The UL file reference is: NMMS / 7. E171230.

### 14.2 Applicant and Listee

Nidec Control Techniques Ltd  
The Gro  
Pool Road  
Newtown  
Powys  
SY16 3BE  
UK.

### 14.3 Manufacturer

Products are manufactured at several sites worldwide. Primary manufacturing site:  
Nidec Industrial Automation UK Ltd  
Unit 79  
Mochdre Industrial Estate  
Newtown  
Powys  
SY16 4LE  
UK.  
The Manufacturing Location Code is: 8D14

### 14.4 Model numbers

Model numbers are listed within the 'Ratings' section (Chapter 2 - Product Information) of the *Digitax HD M75X Series Installation and Technical Guide*.

### 14.5 Safety information

Appropriate installation warnings, cautions and notes are located in the Chapter 1 *Safety information* on page 8.

### 14.6 Adjustments

The *Digitax HD M75X Series Installation and Technical Guide* gives details of all safety-relevant adjustments intended for the user. The identification or function of each control or indicating device and fuse is clearly marked in the diagrams in the *Digitax HD M75X Series Installation and Technical Guide*.

Maintenance adjustments are also described in the *Digitax HD M75X Series Installation and Technical Guide*. They should only be made by qualified personnel. Clear warnings are provided where excessive adjustment could lead to a hazardous state of the Power Drive System (PDS), Complete Drive Module (CDM) or Basic Drive Module (BDM). Any special equipment necessary for making adjustments is specified and described in the 'Mechanical Installation' (Chapter 3) of the *Digitax HD M75X Series Installation and Technical Guide*.

### 14.7 Ratings

The electrical ratings are listed within the 'Ratings' section (Chapter 2 - Product Information) of the *Digitax HD M75X Series Installation and Technical Guide*.

### 14.8 Short circuit current rating

All drives:

5 kA when protected by Listed fuses as specified in the *Digitax HD M75X Series Installation and Technical Guide*.

100 kA when protected by recognized supplemental fuses as specified in the *Digitax HD M75X Series Installation and Technical Guide*.

### 14.9 Overvoltage category

The Over Voltage Category is OVC III.

OVC III applies to equipment permanently connected in fixed installations (Downstream of and including the main distribution board).

### 14.10 Input current, fuse ratings and cable sizes

Electrical installation shall be in accordance with the US National Electrical Code, the Canadian Electrical Code and any additional local codes, as required.

The ground (earth) connections and the DC power connections must use UL Listed ring terminals sized according to the field wiring. Only one cable is permitted to be connected to each field wiring terminal.

The recommended cable sizes and fuse ratings are shown in the 'Technical Data' (Chapter 6) of the *Digitax HD M75X Series Installation and Technical Guide*.

Opening of the branch-circuit protective device may be an indication that a fault has been interrupted. To reduce the risk of fire or electric shock, the equipment should be examined and replaced if damaged. If burnout of the current element of an overload relay occurs, the complete overload relay must be replaced.

Integral solid state short circuit protection does not provide branch circuit protection. Branch circuit protection must be provided in accordance with the National Electrical Code (NEC), The Canadian Electrical Code, and any additional local codes.

### 14.11 Motor cable size and maximum length

The recommended motor cable sizes and maximum length are shown in the 'Technical Data' (Chapter 6) of the *Digitax HD M75X Series Installation and Technical Guide*.

### 14.12 Multiple wiring arrangements

The drives are able to operate from either a single phase or a three-phase AC supply.

Additionally, the drives are able to operate from a DC supply with a range from 24 Vdc up to the maximum rated DC supply voltage.

It is possible for the drive to go from operating on a normal line power supply voltage to operating on a much lower supply voltage without interruption. The wiring arrangements are shown in the 'Electrical installation' (Chapter 4) of the *Digitax HD M75X Series Installation and Technical Guide*.

### 14.13 External 24 V supply

An external 24 Vdc supply is required to power the low voltage circuits within the drive. The low voltage circuits are isolated from the live circuits.

The 24 V supply must be protected by a supplemental fuse.

Refer to the 'Electrical installation' (Chapter 4) of the *Digitax HD M75X Series Installation and Technical Guide*.

### 14.14 Common DC bus systems

Multiple drives can be connected together via a common DC bus. For further details, refer to 'Multi axis system design' (Chapter 5) of the *Digitax HD M75X Series Installation and Technical Guide*.

## 14.15 Solid state short circuit protection

Integral solid state short circuit protection is provided. However, this does not provide branch circuit protection.

In the event of a ground (earth) fault within the drive, the input protective devices (fuses or circuit breaker) provide overcurrent protection in the usual way.

All AC drives incorporate solid state short circuit protection. If a ground (earth) fault occurs in the motor circuit, the solid-state protection operates, the inverter trips and all power switches (IGBTs) are switched off within a very short time, typically less than 10  $\mu$ s. The total trip time is unlikely to exceed 100  $\mu$ s.

In the event of failure of the solid state short circuit protection, one or more of the inverter power devices then fails either open or short circuit. If the failure mode is open-circuit, the fault is interrupted. If the failure mode is short-circuit, the input protection devices (fuses or circuit breaker) clear the fault and open the circuit.

## 14.16 Motor overload protection

All models incorporate internal overload protection for the motor load that does not require the use of an external or remote overload protection device.

## 14.17 Motor overload protection and thermal memory retention

All drives incorporate internal overload protection for the motor load that does not require the use of an external or remote overload protection device. The protection level is adjustable and the method of adjustment is described in Chapter 8 *Optimization* on page 76.

The protection levels are expressed as a percentage of full load current. In order for the motor protection to work properly, the motor rated current must be entered into Pr **00.046** or Pr **05.007**. The motor overload protection levels may be adjusted below 250 % (RFC-S/RFC-A) or 165 % (Open loop) if required

The drives are provided with user terminals that can be connected to a motor thermistor to protect the motor from high temperature, in the event of a motor cooling fan failure.

## 14.18 Enclosure rating

All drives are Open Type.

## 14.19 Mounting

Drives may be mounted

- Singly
- Side by side
- Stacked one above another when fitted with a rear vent kit

The drives are equipped with a rear vent that allows heated air to be exhausted from the rear of the drive rather than the through the top. This mounting arrangement provides the following benefits:

- Reduction in enclosure size.
- Allow vertical stacking of drives.
- Reduce the need for a secondary enclosure fan.

Refer to the 'Mechanical Installation' (Chapter 3) of the *Digitax HD M75X Series Installation and Technical Guide*.

For compact multi axis installations, the rear venting kit allows drives to be vertically mounted one above the other, where this is the case, a minimum clearance of 100 mm (3.94 in) should be maintained between drives.

A current derating must be applied to the drive if the rear vent kit is installed. Derating information is provided in the 'Technical Data' (Chapter 6) of the *Digitax HD M75X Series Installation and Technical Guide*. Failure to do so may result in nuisance tripping.

## 14.20 Operating temperature

The drives are suitable for use up to 40 °C (104 °F) surrounding air temperature. Operation up to 55 °C (131 °F) is permitted with de-rated output. Refer to the 'Technical Data' (Chapter 6) of the *Digitax HD M75X Series Installation and Technical Guide*.

## 14.21 Pollution degree

Drives are designed for operation in a pollution degree 2 environment or better (dry, non-conductive pollution only).

## 14.22 Plenum rating

The drives are not suitable for installation in a compartment (duct) handling conditioned air.

---

# Index

---

## Symbols

+24V user output ..... 23

## Numerics

0V (Common connection for all external devices) ..... 22

## A

Acceleration ..... 48, 59, 61, 62, 63, 65  
Advanced menus ..... 36  
Advanced parameters ..... 123  
Alarm ..... 250  
Alarm Indications ..... 250  
Assembly object ..... 102  
Autotune ..... 81

## B

Basic requirements ..... 57  
Basic speed and torque feedback ..... 105  
Basic speed control ..... 102  
Basic speed feedback ..... 104

## C

Cautions ..... 8  
Control connections ..... 21  
Current limit ..... 48  
Current limits ..... 91  
Current loop gains ..... 77, 79

## D

Deceleration ..... 50, 59, 61, 62, 63, 65  
Defaults (restoring parameter) ..... 38  
Destination parameter ..... 21  
Diagnostics ..... 217  
Digital Input 4 ..... 23  
Digital Input 5 ..... 23  
Digital Output 2 ..... 23  
Digitax HD M753 Control terminal specification ..... 22  
Display messages ..... 37  
Drive enable ..... 22

## E

Encoder feedback limits ..... 92  
Encoder types ..... 24  
Extended speed control ..... 103

## F

Features / specification ..... 113  
Field weakening (constant power) operation ..... 92  
Fixed V/F mode ..... 11

## G

Getting Started ..... 31

## H

High speed operation ..... 92

## K

Keypad operation ..... 33

## M

Maximum speed / frequency ..... 92  
Mechanical Installation ..... 15  
Menu 0 ..... 36  
Menu 01 - Frequency / speed reference ..... 136  
Menu 02 - Ramps ..... 140  
Menu 03 - Slave frequency, speed feedback and  
speed control ..... 143  
Menu 04 - Torque and current control ..... 154  
Menu 05 - Motor control ..... 158  
Menu 06 - Sequencer and clock ..... 165  
Menu 07 - Analog I/O ..... 169  
Menu 08 - Digital I/O ..... 172  
Menu 09 - Programmable logic, motorized pot and  
binary sum ..... 176  
Menu 10 - Status and trips ..... 182  
Menu 11 - General drive set-up ..... 184  
Menu 12 - Threshold detectors and variable selectors ..... 186  
Menu 13 - Standard motion controller ..... 196  
Menu 14 - User PID controller ..... 200  
Menu 15, 16 and 17 - Option module set-up ..... 204  
Menu 17 - Ethernet Interface - Set-up ..... 205  
Menu 18 - Application menu 1 ..... 205  
Menu 19 - Application menu 2 ..... 205  
Menu 20 - Application menu 3 ..... 205  
Menu 21 - Second motor parameters ..... 206  
Menu 22 - Additional Menu 0 set-up ..... 207  
Menu structure ..... 35  
Minimum connections to get the motor running in  
any operating mode ..... 58  
Modbus function codes ..... 95  
Mode parameter ..... 21  
Monitoring ..... 50  
Motor (running the motor) ..... 57  
Motor number of poles ..... 81  
Motor parameters ..... 54  
Motor rated current ..... 81  
Motor rated frequency ..... 81  
Motor rated power factor ..... 81  
Motor rated speed ..... 81  
Motor rated voltage ..... 81  
Motor thermal protection ..... 91

## N

Notes ..... 8

## O

Object Model ..... 107  
Onboard PLC ..... 121  
Open loop mode ..... 11  
Open loop vector mode ..... 11  
Operating mode (changing) ..... 38, 57  
Operating modes ..... 11  
Operating-mode selection ..... 55  
Optimization ..... 76, 94  
Option Module ..... 204  
Option Module - Installing / removing ..... 15  
Options ..... 13

<b>P</b>		<b>V</b>	
Parameter access level .....	38	Voltage boost .....	49
Parameter ranges .....	126	Voltage mode .....	82
Parameter security .....	38	<b>W</b>	
Parameter x.00 .....	48	Warnings .....	8
PLC .....	113		
Position feedback .....	57		
Position feedback connections .....	23		
Position feedback module category parameters .....	204		
Product information .....	10		
PROFINET IO communications .....	113		
<b>Q</b>			
Quadratic V/F mode .....	11		
Quick start commissioning .....	61		
Quick start commissioning / Start-up .....	59		
Quick start connections .....	57		
<b>R</b>			
Ramps .....	48		
Read consistency .....	101		
Registers .....	95		
Requested Packet Interval (RPI) Timeout Trip .....	101		
RFC-A mode .....	11		
<b>S</b>			
Safe Torque Off .....	29		
Safe Torque Off/drive enable .....	22		
Safety Information .....	8		
Saving parameters .....	38		
SD card operation .....	117		
Serial communications connections .....	21		
Serial communications look-up table .....	220		
Single line descriptions .....	41		
Slot 3 Menu 0: Ethernet set-up .....	208		
Slot 3 Menu 10: Easy Mode .....	210		
Slot 3 Menu 11: Synchronization .....	212		
Slot 3 Menu 15: Modbus .....	212		
Slot 3 Menu 2: Ethernet configuration .....	209		
Slot 3 Menu 20: EtherNet/IP .....	213		
Slot 3 Menu 21: EtherNet/IP In Mappings .....	214		
Slot 3 Menu 22: EtherNet/IP Out Mappings .....	215		
Slot 3 Menu 23: EtherNet/IP Fault Values .....	216		
Slot 3 Menu 24: Profinet Set-up .....	216		
Slot 3 Menu 9: Resources .....	209		
Speed feedback .....	57		
Speed loop gains .....	77, 78, 80, 87, 90		
Speed reference selection .....	48		
Speed-loop PID gains .....	49		
Status .....	250		
Status Indications .....	250		
Status information .....	56		
Supported drive assembly objects .....	102		
Switching frequency .....	91, 92		
<b>T</b>			
Trip .....	217		
Trip History .....	251		
Trip Indications .....	217		
<b>U</b>			
User Security .....	39		



**0478-0530-01**