

IN-GSM

IN-GSM ANT3

Universal GSM module

The IN-GSM universal data transmission module is intended for recording the readings from water meters manufactured by Apator Powogaz S.A. and transmission of the data over GPRS in GSM (cellular) networks. The module is installed on the water meter with or without an interface ring, in the specified installation orientation. This device features uniquely extensive local and remote configuration of its operating parameters. The device is powered by a battery which can be replaced with great ease. The device requires no external power source and maintains the IP68 protection rating in operation. The battery life can reach up to 6 years under the standard transmission configuration with a predefined data transmission schedule and environmental conditions (class T50).

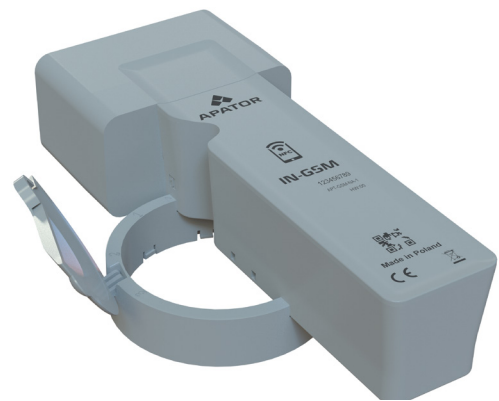

The module enables recording and transmission of data under rated operating conditions, with detection and logging of events with periodic output of event indications (alarms) over a 2G GSM network or in text messages (SMS). In monitoring mode (with the data logging down to every 10 minutes), the module can record the data on daily flow rates (this data is contained in q-profiles, while the monitoring mode logs the flow rate and its increase), which greatly facilitates proper specification of water meters for water supply service connections.

Application

The IN-GSM universal module is compatible with various water meter types from Apator Powogaz S.A. rated at IP65 or IP68 and induction pointers (Ti). The module is used with water meters in distributed location infrastructure, water meters installed in deep wells, or water meters on water transmission mains. The readings are transmitted over GSM to a server for downloading by distribution centres. The module features inductive scanning of the water meter counter pointer, and with the module's IP68 protection rating, the device is dedicated especially for installation on water meters in difficult ambient conditions (including wet water meter vaults at risk of flooding with water).

Key features

- Compatible with a wide range of flat, house, and industrial water meters from Apator Powogaz S.A.
- Can be installed on a water meter in operation
- High immunity to external EM fields
- Direction of flow sensing
- Quick and easy configuration with dedicated software
- Predefined configuration profiles available in the mobile app with full configurability of the profiles via the web-browser app
- Firmware updates over NFC and GPRS
- Supports custom configuration of the data transmission interval
- Logging of monthly values throughout the product's operating life
- Detection, logging and indication of water usage abnormalities and module performance abnormalities by indication of events
- Asynchronous indication of alarms immediately when set (maximum of 5 alarms a month)
- Output of text messages (SMS) to a configured mobile phone number in the event of a GPRS connection loss or for specific events
- Memory for 13,312 entries
- Battery life of up to 6 years with the standard configuration for temperature class T50 – see the Specifications table for details
- IP68 protection rating
- Supports Eco mode – switching the data transmission mode from GPRS to binary text messages (PDU)
- Easy battery replacement with no need for special technical support or an external power source, with maintained IP68 protection rating and existing functionalities

Device configuration

Configuration mode

- NFC (Near Field Communication) enables comprehensive configuration of the module on the installation site, reading of registers, and testing the quality of GSM operator service
- GSM enables remote configuration of the module via an installation protocol

Data configurable for the module

- Data transmission interval for outbound transmission of logged values to the server: 1 m, 2 m, 5 m, 10 m, 15 m, 30 m, 1 h, 2 h, 4 h, 6 h, 8 h, 12 h, 1 d, 2 d, 3 d, 4 d, 5 d, 6 d, 7 d, 10 d, 15 d, 1 month
- Historical indication memory length: 1 h, 2 h, 4 h, 6 h, 8 h, 12 h, 1 d, 2 d, 3 d, 4 d, 5 d, 6 d, 7 d, 10 d, 15 d, 1 month
- Storage of on-request data transmission configuration and/or text message output whenever an alarm is generated (to a predefined mobile phone number e.g. of the metering network controller)
- Storage of water meter serial number
- Storage indicator revolution weight
- Storage of current indicator revolution number of the water meter
- Storage of event thresholds
- Storage of telemetry server parameters
- Storage of update server parameters
- Storage of mobile phone numbers

Available data

The IN-GSM module supports bidirectional data communication over GPRS and NFC for:

- Reading the module current date and time;
- Reading the stored indication for the correct, reverse, and balanced directions of flow;
- Flow profile in six configurable ranges
- Reading details of alarms and events
- Deleting details of alarms and events
- Module RTC synchronisation
- Reading the parameters from the module memory
- Module firmware update on request
- Server connection on request
- Exiting the warehouse mode

Events

The module records events according to internal algorithms. An event can force the output of a message over GPRS or via SMS if the relevant parameter is configured. For alarm events (*), the message is sent irrespective of the configuration settings. For specific events (**), no messages can be sent. Given the constraint of battery life, the number of alarm text messages (which specify the detected events) is limited to 5 a month; the limit of other text message types is configurable. The module can store up to 15 historical data items on alarms since the last deletion/overwrite of alarm details:

Event types

- Minimum flow (a flow value below a defined flow rate threshold and present longer than a user-defined time limit)
- Maximum flow (*) (a flow value above a defined flow rate threshold and present longer than a user-defined time limit)
- Back flow (the flow in reverse of the normal flow and detected above a user-defined flow rate threshold)
- Leak (*) (an event detected if the water flow is continuous for a user-defined time)
- No measurement change (zero or near-zero flow rate – per the user-defined water meter indications detected over a defined time)
- Low battery (below a specified battery charge threshold)
- Low battery voltage (**)
- Monthly text message limit achieved
- Emergency text message output (the message of the water meter status when GPRS connectivity is lost)
- Failed GPRS connection (**)
- Failed text message output (**)
- Poor GSM service (**)
- Battery disconnected (**)
- Magnetic field detected (*)
- Module removed from the water meter (*)
- Below the minimum operating temperature (*)
- Above the maximum operating temperature (*)

Monitoring

The module can switch to a monitoring mode which logs the readings at a higher frequency to determine the operating profile of the water meter.

Configuration of the monitoring mode:

- Mode enabled on request or as configured
- Indication memory length: 10 s, 30 s, 1 min, 2 min, 5 min, 10 min, 15 min, 30 min, 1 h, 2 h, 4 h, 6 h, 8 h, 12 h, 24 h,
- 24 switchovers to the monitoring mode within the battery life.
- Up to 7 days in the monitoring mode
- Optional: one daily transmission of status or at the exit from the monitoring mode

Regulatory and standard compliance

- Compliant with Directive 2014/53/EU of the European Parliament and of the Council of 16 April 2014 on the harmonisation of the laws of the Member States relating to the making available on the market of radio equipment and repealing Directive 1999/5/EC.
- ETSI EN 300 220-1 V2.4.1. Electromagnetic compatibility and Radio spectrum Matters (ERM); Short Range Devices (SRD); Radio equipment to be used in the 25 MHz to 1,000 MHz frequency range with power levels ranging up to 500 mW. Part 1: Technical characteristics and test methods
- ETSI EN 300 220-2 V2.4.1. Electromagnetic compatibility and Radio spectrum Matters (ERM); Short Range Devices (SRD); Radio equipment to be used in the 25 MHz to 1,000 MHz frequency range with power levels ranging up to 500 mW. Part 2: Harmonised Standard for compliance with the essential requirements of R&TTE Article 3.2.
- ETSI EN 301 489-1 V1.9.2. Electromagnetic compatibility and Radio spectrum Matters (ERM); Electromagnetic Compatibility (EMC) standard for radio equipment and services. Part 1: Common technical requirements.
- ETSI EN 301 489-3 V1.6.1. Electromagnetic compatibility and Radio spectrum Matters (ERM); Electromagnetic Compatibility (EMC) standard for radio equipment and services. Part 3: Specific conditions for Short Range Devices (SRD) operating on frequencies between 9 kHz and 246 GHz.
- PN-EN 60950-1:2007 PN-EN 60950-1:2007 +A11:2009 +A1:2011 +A12:2011. Information technology equipment — Safety — Part 1.

Specifications

Module	IN-GSM	IN-GSM ANT3
Antenna	Internal	External antenna cable length 3 m
Installation method	With or without an interface ring (depending on the water meter version, IP65 or IP68) on the water meter counter – mechanical lock (installation seal) for protection against unauthorised removal of the module.	
Installation orientation	Horizontal or vertical	
Device operating time	Up to 6 years, depending on the configuration* and operating temperature**. * Logging the water meter status ever 1 h, data transmission every 24 h; monitoring/flow monitor mode run up to 24 times over the product service life (maximum status logging frequency 10 min, data transmission every 24 h for up to 7 days); up to 5 alarms transmitted every month. ** Module operation in the following temperature ranges: 10% of operating time at 10°C, 80% of operating time at 20°C, and 10% of operating time at 30°C	
Correct performance temperature limits	-15°C to 60°C	
Ingress protection rating	IP68	
Installation requirements	Do not use near strong EM fields or in locations which can severely attenuate the GSM service.	
Transmission interval	1 m, 2 m, 5 m, 10 m, 15 m, 30 m, 1 h, 2 h, 4 h, 6 h, 8 h, 12 h, 1 d, 2 d, 3 d, 4 d, 5 d, 6 d, 7 d, 10 d, 15 d, 1 month	
SIM card	USIM, type MFF2	
Power supply	Replaceable M20 lithium battery (serviced by authorised technicians or the customer), nominal voltage 3.0 V, max. capacity 12.5 Ah	
Transmission type	NFC, compliant with ISO/IEC 15693, 13.56 MHz GPRS SMS / PDU binary SMS	
Protocol	ATDP	
GSM modem	2G, 900 MHz / 1800 MHz	
Transmitter power output	min. 5 dBm, max. 33 dBm	
Power output level stability	±5 dB	
Receiver sensitivity	< -109 dBm	
Outdoor range	Depending on the landscape configuration and the distance to and location of the BTS	
Memory	13312 entries	
Dimensions	176 x 45 x 72 mm	270 x 60 x 72 mm
Weight	312 g	363 g

Module elements and accessories

Induction overlay

IN-GSM

with **INTERNAL** antenna
with IP68 protection level, to be mounted on the counter of water meters manufactured by Apator Powogaz.

nr 30-3170-000000



Induction overlay

IN-GSM ANT3

with an **EXTERNAL** antenna
with IP68 protection level
for installation on the water meter of Apator Powogaz.

nr 30-3171-000000



Module elements



Electronic module
32-3170-010000



Electronic module with external antenna
32-3171-010000

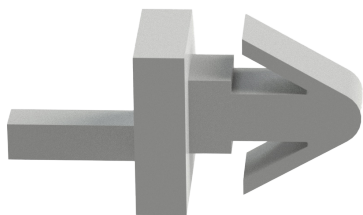

Sealing lock IN-GSM
33-3170-000005

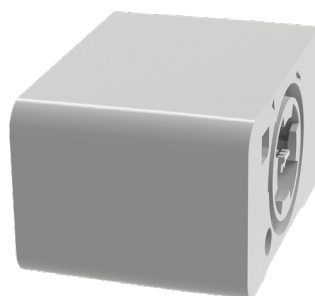

Battery module
32-3170-020000

Accessories for overlays IN-GSM i IN-GSM ANT3

Induction pads with numbers: 30-3170-000000 and 30-3171-000000 are equipped with the accessories listed below in each set, which enable installation on an **IP65/IP68 water meter**.

IP65



Lid
33-3160-000004

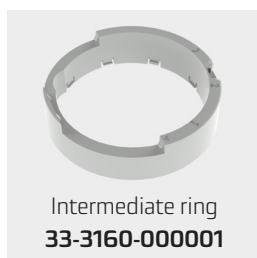

Intermediate ring
33-3160-000001

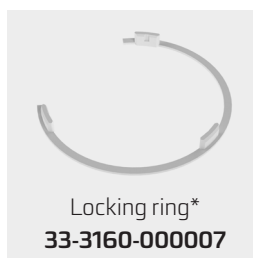

Locking ring*
33-3160-000007

IP68

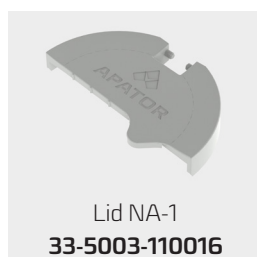

Lid NA-1
33-5003-110016

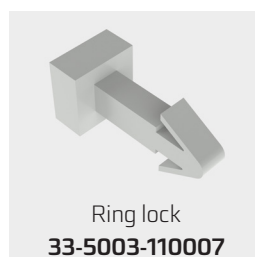

Ring lock
33-5003-110007

* The locking ring (33-3160-000007) is used in assembly for residential water metres (excluding JS Smart D+) and in home JS Master +/C+/D+.

Dimensions and installation orientations of the module with the interface ring on Apator Powogaz IP65 water meters

JS SMART

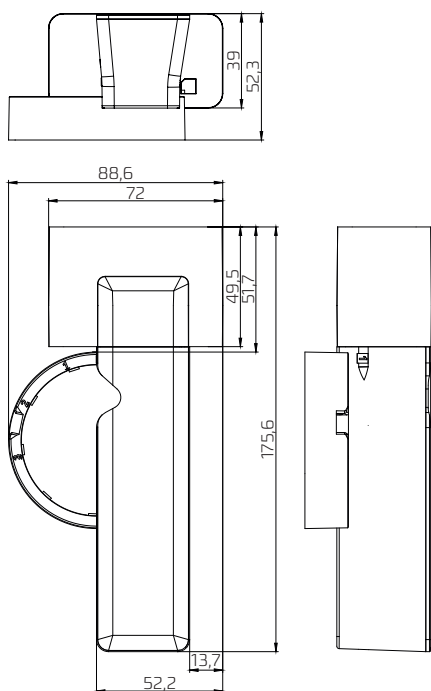

JS MASTER; JS IMPERO; MWN

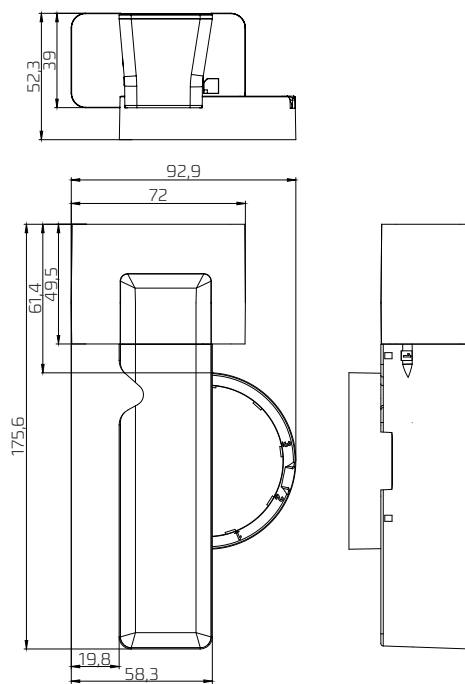

Installation of the IN-GSM module on Apator Powogaz water meters

Module w/o the interface ring, installed on IP68 home and industrial water meters.

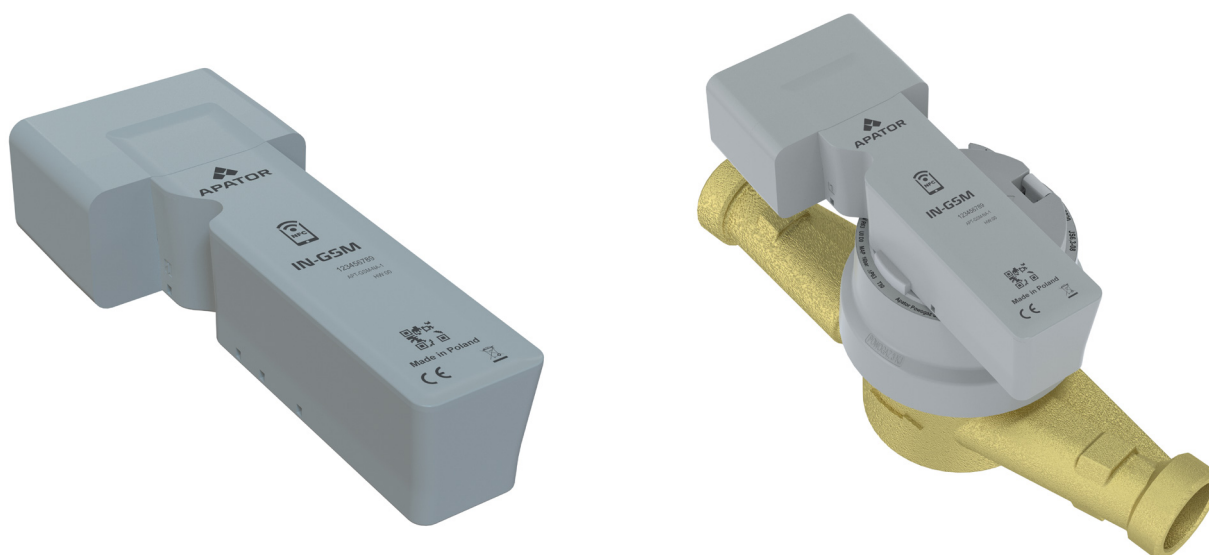

Securing the module to an IP68 counter cover with an installation seal.

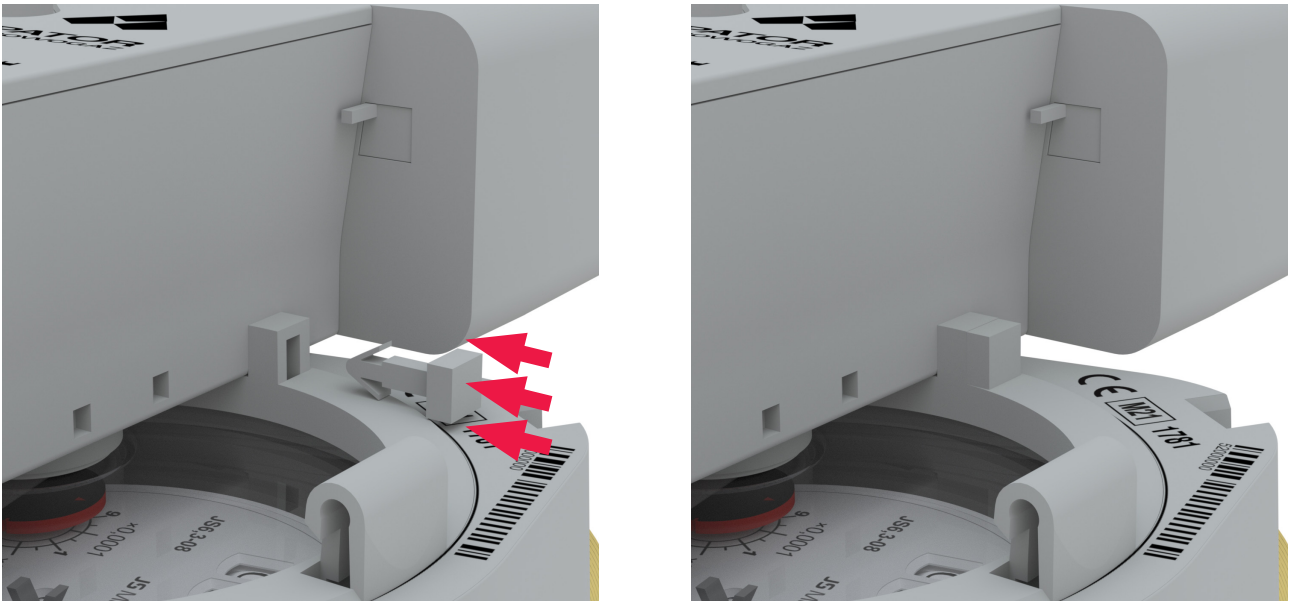

The installation seal is intended to provide a mechanical seal of the RF module on the water meter. The seal secures against unauthorised removal of and tampering with the RF module indications. Unlike sticker seals, it is perfectly weather-resistant.

Module with an interface ring, mounted on residential, domestic and industrial IP65 water meters.

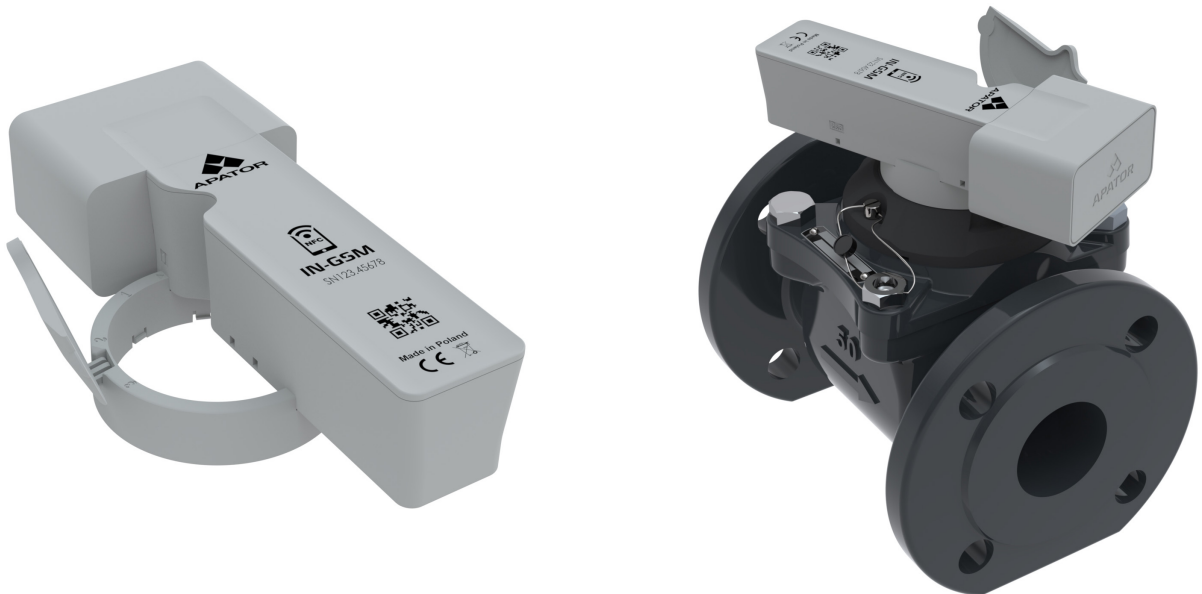

Battery removal and installation



The mechanical seal, fails when unauthorised removal of the battery is attempted.

To replace the battery, remove the module from the water meter. Grasp the longer part of the module (with the legend markings) with one hand and the other part (plain) with the other hand, and rotate by approx. 45°.

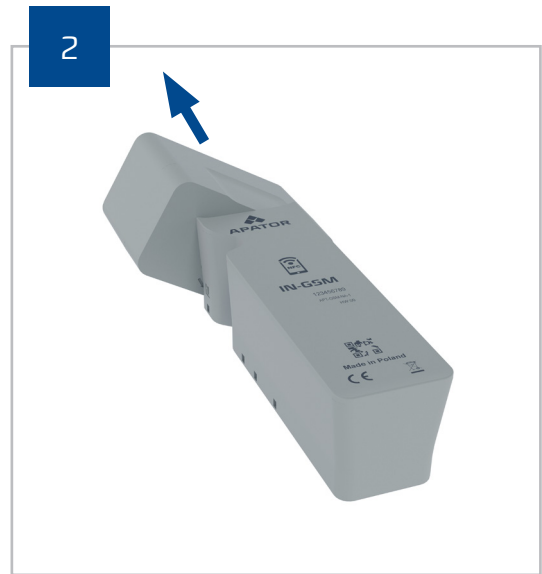

Once the parts have been rotated by approx. 45°, pull the battery in the direction shown by the arrow to remove the battery pack from the electronic module and disconnect the wiring.



Battery shown removed.

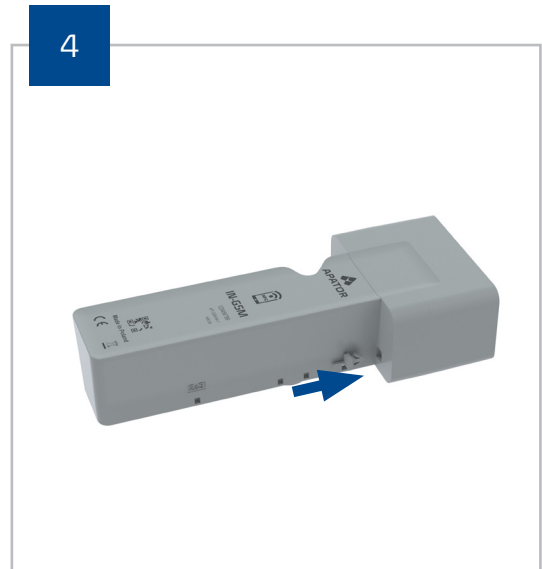

Install a new battery by following the removal procedure in the reverse order: note the correct connection sequence of the battery-to-electronic module power wires.

With the battery replaced, insert the seal piece into the hole on the battery module to secure the module against tampering.

The data shown here is current on the date of issue.
The manufacturer has the right to modify and improve the products without notice.
This publication is indicative only and should not be construed as a commercial offer under the Polish Civil Code.



Apator Powogaz S.A.

Jaryszki 1c, 62-023 Żerniki

Secretariat: sekretariat.powogaz@apator.com, tel. +48 61 84 18 101

Sales Department / Customer Service: tel: +48 61 84 18 149

Customer Service Center: handel.powogaz@apator.com

Export: export.powogaz@apator.com

Technical support: support.powogaz@apator.com, tel. +48 61 8418 131, 134, 294

Complaints: reklamacje.powogaz@apator.com