

Operating manual

IN-GSM, IN-GSM ANT3 universal inductive module for communication in GSM network

Version 1.0

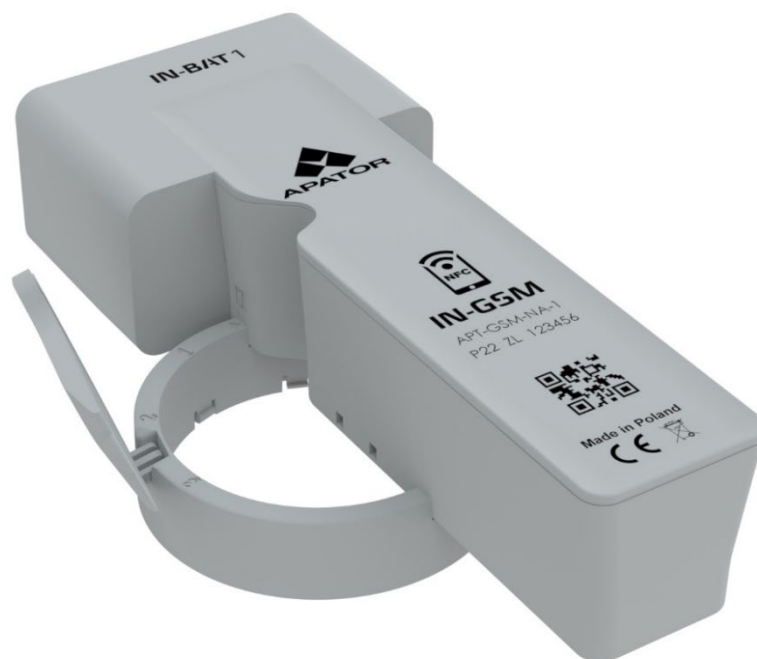

ISO 9001

ISO 14001

ISO 45001

Table of contents

1.	Application	5
2.	Device description	6
3.	Basic components of the IN-GSM module for installation on IP65/IP68 water meters.....	7
4.	Technical specifications.....	9
4.1.	Dimensions of the transmission module and water meter set (IP65) with the module installed	10
5.	Device functions	11
5.1.	Time zones	11
5.1.1.	Time zone	11
5.1.2.	Daylight saving time (DST)	12
5.1.3.	Setting the device time	12
5.1.4.	Time presentation	12
5.2.	Communication interface	12
5.2.1.	GSM.....	12
5.2.2.	NFC.....	12
5.3.	Data types.....	13
5.3.1.	Registers.....	13
5.3.2.	Archives	13
5.3.3.	Non-volatile memory	13
5.4.	Monitoring mode.....	13
5.5.	Archives and files	13
6.	Scenarios.....	14
6.1.	Storage.....	14
6.2.	Transport	14
6.3.	Preparing the device for operation.....	14
6.3.1.	GSM service check	14
7.	Installation of the IN-GSM universal module on Apator Powogaz water meters	15
7.1.	Installation prerequisites.....	15
7.2.	Installation on apartment water meters: JS Smart +; JS Smart C+ and JS Smart D+(DN15 or DN20; T50 or T90) in the IP65/IP68 version.....	17

7.2.1	Positioning and fixing the intermediate ring assembly on the counter assembly and checking the installation correctness.....	17
7.2.1.	Transmission module installation.....	20
7.3.	Installation on a house water meter, type JS Master +, JS Master C+ and JS Master D+(DN25 – DN40; T50 or T130) in the IP65 version.....	22
7.3.1.	Positioning and fixing the intermediate ring assembly on the counter assembly and checking the installation correctness.....	22
7.3.2.	Transmission module installation.....	25
7.4.	Installation on a house water meter, type JS Master (DN25 – DN40; T50), in the IP68 version	26
7.5.	Installation on industrial water meters type MWN (T50 or T130), JS(T50), MK (T50), IP65 version.....	28
7.6.	Installation on industrial water meters type MWN (T50), JS (T50), MK (T50), IP68 version.....	30
7.7.	Installing an external antenna.....	33
7.8.	Configuration	35
7.8.1.	Exiting the storage mode	35
7.8.2.	Configuration of module with water meter	35
7.8.3.	Counter calibration.....	35
7.9.	Operation	36
7.9.1.	Data readout	36
7.9.2.	Local readout	36
7.9.3.	Remote readout	36
7.9.4.	Event alerts and alarms	36
7.9.5.	Water meter monitoring	41
7.9.6.	Emergency text message	41
7.10.	Removal.....	42
7.10.1.	Removal of the IN-GSM inductive transmission module from a water meter.....	42
7.9.1	Battery replacement	46
7.10	Diagnostics and maintenance	49
7.10.1.	Coil test mode	49
7.10.2.	GSM connection test	49
7.10.3.	Reprogramming	49
7.11	Water meter replacement	49
8.	Operating precautions.....	50

9.	Warranty terms and conditions	50
10.	Environmental protection.....	50

1. Application

IN-GSM¹ is a universal communication module facilitating remote readout of water meters manufactured by Apator Powogaz S.A. This device counts revolutions of a dedicated water meter indicator, and the data obtained is transferred to the server via a GSM network. Revolutions are detected by an induction scanning module.

Table 1. Compatibility

Type and name of the water meter	Q ₃ [m ³ /h] or DN [mm]	Revolution weight [dm ³ /rev.]	Temperature class
JS Smart D+	Q ₃ 1.6 ÷ 4	1	T50 / T90
JS Smart C+	Q ₃ 1.6 ÷ 4	1	T50 / T90
JS Smart +	Q ₃ 1.6 ÷ 4	1	T50 / T90
JS Master D+	Q ₃ 6.3 ÷ 16	1	T50
JS Master C+	Q ₃ 6.3 ÷ 16	1	T50
JS Master +	Q ₃ 6.3 ÷ 16	1	T50 / T130
JS Impero	Q ₃ 50 ÷ 100	10	T50
MWN Nubis	DN 40 ÷ 125	10	T50 / T130
MWN Nubis	DN 150 ÷ 400	100	T50
MWN Nubis	DN 150 ÷ 300	100	T130
MK	DN 50 ÷ 100	10	T50
MK	DN 150	100	T50
WI	DN 40÷250	100	T30 / T50

¹ All information concerning IN-GSM also refers to the IN-GSM ANT3 device, unless a difference is clearly specified.

2. Device description

IN-GSM is a battery-operated electronic device designed as part of the AMR (automatic meter reading) system intended mainly for water supply pipelines. Its main task is to transmit information regarding water meter status via GPRS communication to the cloud server.

The device has been designed to work in difficult environmental conditions, such as water meter wells, basements, etc. Such features as the inductive water meter reading interface and IP68 enclosure facilitate its operation in high humidity conditions and at water presence² in a water meter well. An IN-GSM ANT3 device version with an extended antenna line (3 metres) for installation in deep or flooded water meter wells and other difficult locations is also available.

The device comes with an NFC communication module facilitating local configuration during assembly, as well as servicing and diagnostic activities.

The operating time and configuration are selected so that the device operates for one validation period of a water meter, and its replaceable battery module makes it possible to use the device during the next verification period.

The device comes with the following communication interfaces:

- indicator revolution inductive sensor;
- remote communication interface - 2G GSM (GPRS or SMS communication);
- local communication interface - NFC;
- magnetic field sensor.

Basic device functionalities:

- water meter readout recording (forward and back water flow);
- event detection and alerting (GPRS or SMS communication);
- data transmission (GSM) to a server, according to a schedule;
- on-demand data transmission (GSM) (forcing transmission via NFC);
- water meter profiling (water meter volume recording in defined flow ranges).

Events detected and recorded by the device:

- minimum flow;
- maximum flow;
- back flow;
- leaks;
- measurement unchanged.

² Due to the nature of electromagnetic waves, the device establishes communication correctly, only if its antenna is submerged.

3. Basic components of the IN-GSM module for installation on IP65/IP68 water meters

- Transmission module - main device module responsible for GSM communication
- Battery module - facilitates battery replacement during device operation
- Intermediate ring - ring facilitating correct positioning and installation of the module on various types of water meters manufactured by Apator Powogaz. The IP68 water meter version does not use the ring, as its role is fulfilled by a special counter guard with a #UTIP (Universal TI Plug) connector.
- Locking ring*
- Cover - protection cover for water meter counter
- Battery seal - seal indicating battery disconnection
- Sealing lock - stud permanently fixing the module to the counter guard

Table 2. Basic components of the IN-GSM module facilitating installation on IP65/68 water meters

<p>Induction module</p> <p>IN-GSM</p> <p>with INTERNAL antenna</p> <p>and the IP68 degree of protection, to be installed on the water meter counters manufactured by Apator Powogaz</p>	<p>Induction module</p> <p>IN-GSM ANT3</p> <p>with EXTERNAL antenna</p> <p>and the IP68 degree of protection, to be installed on the water meter counters manufactured by Apator Powogaz</p>
---	--

no. **30-3170-00000**



no. **30-3171-00000**



Module elements



Electronic module
32-3170-010000



Electronic module with external antenna
32-3171-010000

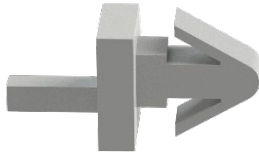

INGSM sealing lock
33-3170-000005

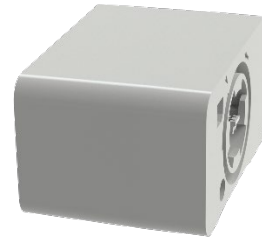

Battery module
32-3170-020000

Accessories for IN-GSM and IN-GSM ANT3 overlays

Inductive overlays with numbers: 30-3170-000000 and 30-3171-000000 in each set are equipped with the accessories listed below to facilitate **IP65/IP68 water meter** installation.

IP65

 <p>Cover 33-3160-000004</p>	 <p>Intermediate ring 33-3160-000001</p>	 <p>Locking ring* 33-3160-000007</p>
--	--	---

IP68

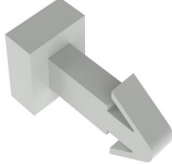
 <p>NA-1 cover 33-5003-110016</p>	 <p>Ring lock 33-5003-110007</p>
--	--

*The locking ring (33-3160-000007) is used in apartment water meter assemblies (excluding JS Smart D+) and JS Master +/C+/D+ house water meter assemblies.

4. Technical specifications

Table 3. Technical specifications

Module	IN-GSM	IN-GSM ANT3
Antenna	IN-GSM - internal antenna	IN-GSM ANT3 - external antenna (3 m line)
Installation method	Direct installation of the IP68 version on a water meter with the UTIP (Universal TI Plug) connector (lock protecting against unauthorised module removal) or with an intermediate ring on the water meter (IP65 version)	
Installation position	Horizontal and vertical	
Installation requirements	Do not install near strong EM fields or in locations which can severely attenuate the GSM service.	
Pulse counting method	Induction resonance module	
Water meter indicator rotational speed	Max. 9 rpm	
Power supply	Replaceable M20 lithium battery (serviced by authorised technicians or the customer), nominal voltage 3.0 V, max. capacity 12.5 Ah	
Operating time	Up to 6 years, depending on the configuration* and operating temperature**. *Logging the water meter status ever 1 h, data transmission every 24 h; monitoring/flow monitoring mode activated up to 24 times over the product service life (maximum status logging frequency 10 minutes, data transmission every 24 h for up to 7 days); up to 5 alarms transmitted every month. **Module operation in the following temperature ranges: 10% of operating time at 10°C, 80% of operating time at 20°C, and 10% of operating time at 30°C	
Operating temperature	from -15°C to +60°C	
Degree of protection	IP68	
Protocol	Manufacturer's ATDP	
Transmission type	NFC, as per ISO/IEC 15693, 13.56 MHz, GPRS SMS/or PDU binary SMS	
Transmission interval	1 minute, 2 minutes, 5 minutes, 10 minutes, 15 minutes, 30 minutes, 1 hour, 2 hours, 4 hours, 6 hours, 8 hours, 12 hours, 1 day, 2 days, 3 days, 4 days, 5 days, 6 days, 7 days, 10 days, 15 days, 1 month	
SIM card	Built-in MFF2 card (embedded SIM)	
GSM modem	2G 900 MHz (optional 1800 MHz, different FW version required)	
Transmitter power output	min. 5 dBm, max. 33 dBm	
Power output level stability	±5 dB	
Receiver sensitivity	< -109 dBm	
Range	Depending on the terrain and relay station and device location	
Memory	13312 entries according to documentation	
Weight	312 g	363 g

Dimensions	176 mm x 45 mm x 72 mm	270 mm x 60 mm x 72 mm (antenna on device)
Conformance to standards	See the "CE Declaration" Annex.	

4.1. Dimensions of the transmission module and water meter set (IP65) with the module installed

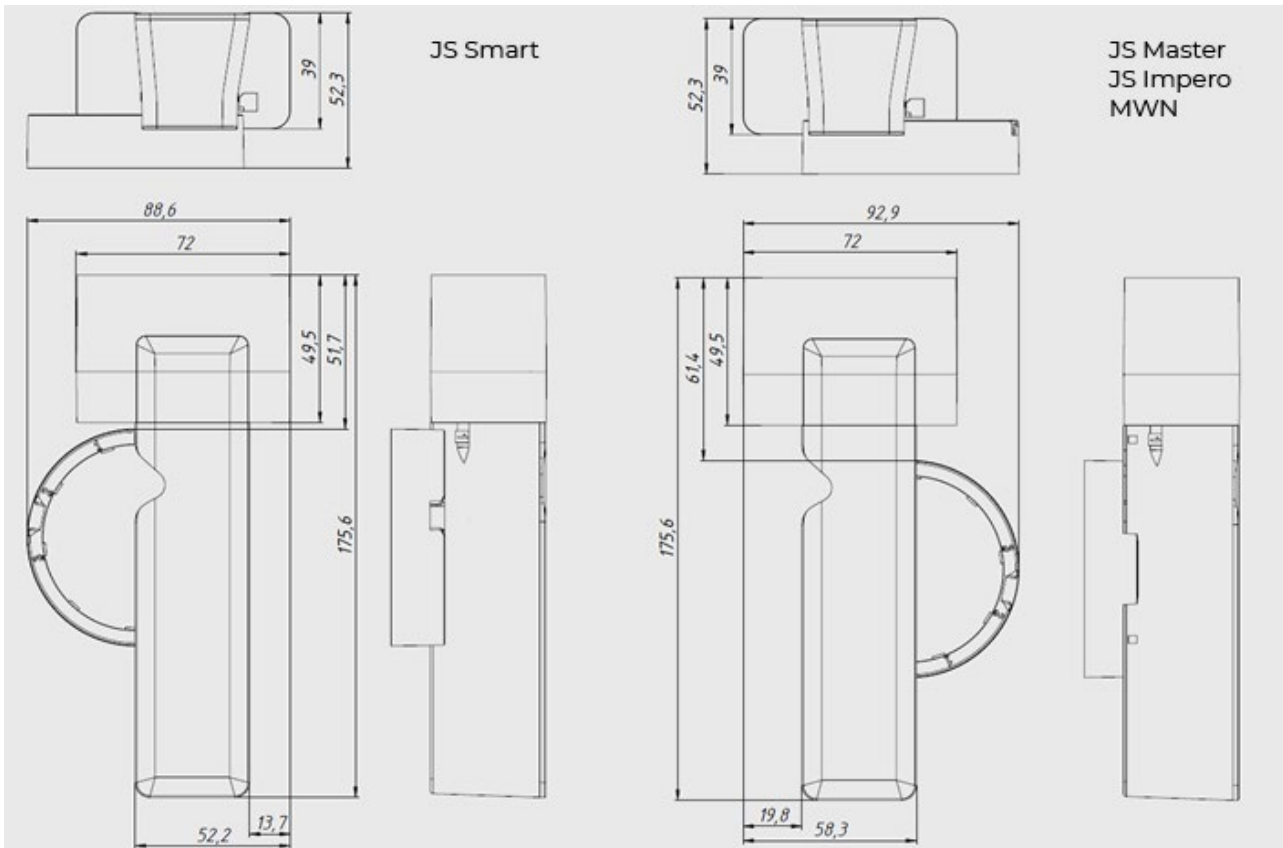

Fig. 1. Overall transmission module dimensions with intermediate ring for water meters

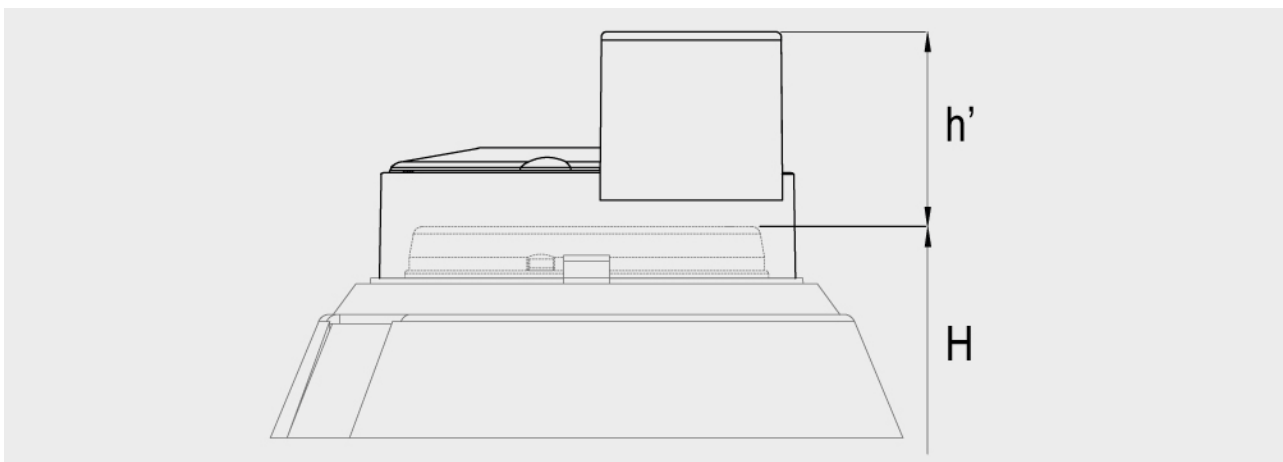

Fig. 2. Water meter height with transmission module

Table 4. Module dimensions with water meter

Water meters/WI meter types	Water meter + module height H + h' [mm]
Apartment meters: JS / (T50 or T90) DN15 or DN20	H* + 41.8
House meters: JS / (T50 or T130) DN25 ÷ DN40	H* + 44.9
Industrial meters: MWN (T50 or T130), JS (T50), MK (T50); MH (T50) and WI T50 (DN as per assigned sizes)	H* + 44.4

*The H values are specified in the product data sheets available at www.apator.com.

5. Device functions

5.1. Time zones

UTC time and local time are indicated in the device.

The local time is used for:

- basic transmissions;
- reading archive latches;
- monthly reading archive latches;
- monitoring mode activation;
- sending emergency text messages, providing current reading time and time logged in an emergency text message.

UTC time is used for time stamps for:

- reading archives;
- queries for data from the reading archives;
- monitoring archive;
- alarm archive;
- event recorder.

Each 32-bit time stamp is a UTC stamp, both read and saved to the device. The time stamp value equal to 0 refers to the date, i.e. 00:00:00 2000/01/01. The stamp indicates the number of seconds that have elapsed since this date. Conversion to local time takes place only for the purposes of text message presentations or scheduled activity performance.

5.1.1. Time zone

To set a time zone, the zone relative to UTC in minutes must be shifted and the check box stating whether DST (Daylight Saving Time) is currently used must be checked.

5.1.2. Daylight saving time (DST)

The device allows makes it possible to plan only one consecutive time change date. Each subsequent change must be ordered by the AMR system.

5.1.3. Setting the device time

The device clock is set by saving the current UTC time stamp. In addition, the time zone, DST and automatic DST change must be set.

To change the time, the following is performed:

- The monitoring mode is stopped (if activated), and it is not restarted automatically.
- The cache of the reading archive and monthly reading archive is cleared, and all readings not saved in the read-only memory are lost (up to 8 readings).
- The time of the next reading latching tasks is recalculated.
- The times of the next basic transmission, monthly text message limit resetting and emergency text message sending are calculated.

In case the time zone settings are changed or the automatic DST change mode is active (from summer to winter time and vice versa), the following operations are performed:

- The monitoring mode is stopped (if activated), but sampling has not yet started. It is resumed automatically in line with the settings, after recalculating the sampling start time. If sampling is already being done, it is not interrupted.
- The cache of the reading archive and monthly reading archive is cleared, and all readings not saved in the read-only memory are lost (up to 8 readings).
- The time of the next reading latching tasks is recalculated.
- The times of the next basic transmission, monthly text message limit resetting and emergency text message sending are calculated.

5.1.4. Time presentation

In text messages, the time is presented in a format compliant with ISO-8601. It includes the date and local time in a text form and time zone offset in the +/-HH:MM format.

Example: 2021-01-07T10:37:08+01:00

5.2. Communication interface

5.2.1. GSM

The device is equipped with a four-band GSM 2G modem, thanks to which it can communicate via GPRS package transmission or text messages.

5.2.2. NFC

The device is equipped with an NFC communication interface facilitating communication with it using a mobile device with the SPIDAP application.

5.3. Data types

5.3.1. Registers

A register is the basic unit of data storage and sharing in the device. Registers contain device configuration and status data. In general, they are data structures whose form depends on the type of information they store.

5.3.2. Archives

Historical metering data and events are stored in archives. They are described in detail in the chapter “Archives and files”.

5.3.3. Non-volatile memory

During a CPU reset, e.g. for battery replacement, some of the data stored in the device memory is retained and some is irretrievably lost.

Retained data:

- Configuration
- Reading archives
- Alarm archives

Volatile data:

- Main counter status
- Event recorder
- Event flags
- Event algorithm states

5.4. Monitoring mode

The monitoring mode is a device operation mode collecting flow samples much more often than the archive reading mechanism allows. After starting the mode, sampling lasts 7 days and the collected data can be read in daily cycles or once after the mode is finished. To start the monitoring mode:

- Run the mode parametrisation.
- Start the mode.

5.5. Archives and files

The device stores the following data in the form of files:

- reading archives;
- monitoring data;
- firmware updates;
- coil test data;
- alarm archive.

Note! If the monitoring mode is activated, data is not recorded in the reading archive. The reading archive recording process is resumed after the monitoring mode is completed.

6. Scenarios

6.1. Storage

During storage, the device should be in the storage mode. It prevents battery discharge and spontaneous generation of events and flows.

Note! In order to ensure the device life of 6 years, the device storage time must not be longer than 1 year, and the storage conditions should be as follows:

- 10% of operating time at 10°C;
- 80% of operating time at 20°C;
- 10% of operating time at 30°C.

6.2. Transport

Similarly to storage, the device should be in storage mode during transport. The device should be transported in dedicated packaging.

6.3. Preparing the device for operation

Correct configuration is required for correct device operation within a water supply network.

6.3.1. GSM service check

Before installing the device on a water meter, first verify the quality of the GSM service in its installation location.

Signal strength	Signal quality
≥ -51 dBm	signal power: excellent
-51 dBm ÷ -73 dBm	signal power: very good
-75 dBm ÷ -85 dBm	signal power: good
-87 dBm ÷ -93 dBm	signal power: weak (a better modem location must be specified or a device with an external antenna must be used)
≤ -95 dBm	signal power: very weak

7. Installation of the IN-GSM universal module on Apator Powogaz water meters

7.1. Installation prerequisites

Each water meter compatible with the IN-GSM universal induction module features a dedicated induction indicator (“TI” or “TI/IR”).

For IP68 water meters, there is a single TI/IR or TI indicator on the counter dial.

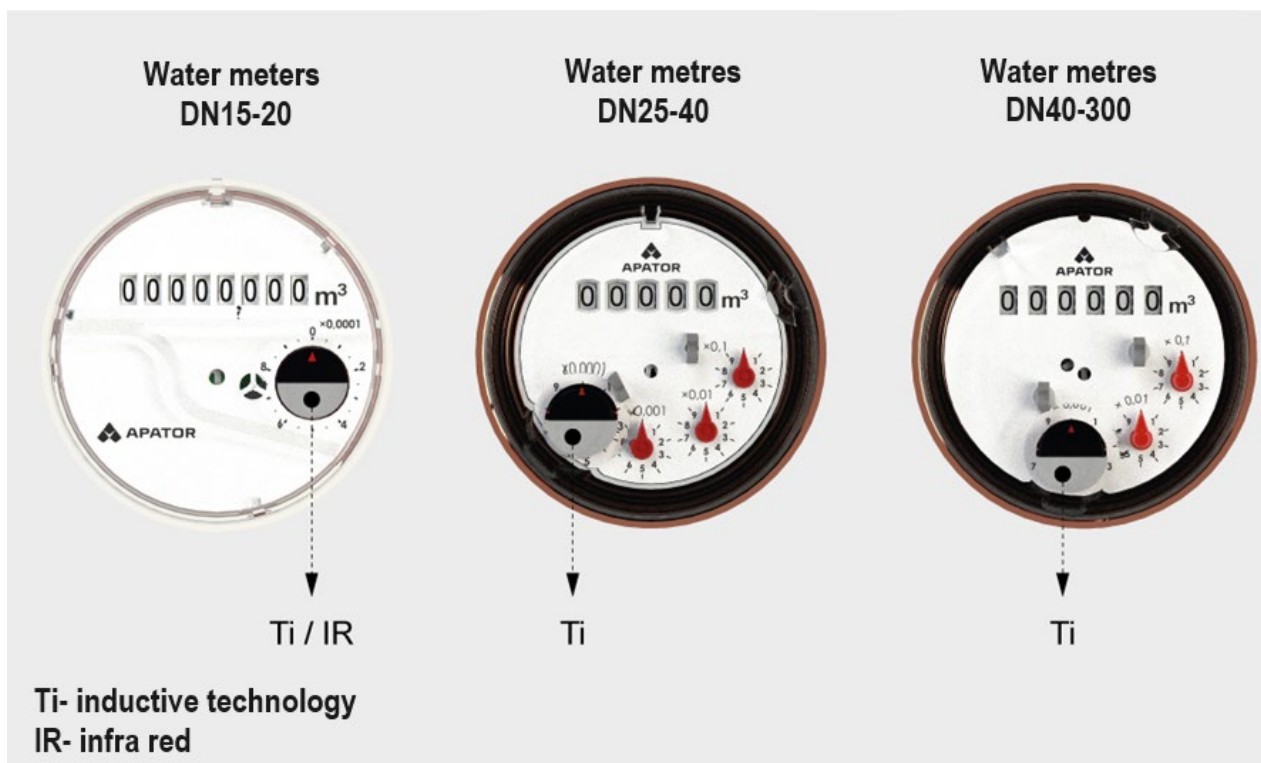

Fig. 3. Compatible data transmission technologies and reading indicator locations

However, for IP65 water meters, there are two independent single TI/IR or TI indicators. Water meter indications can still be read with the existing overlays (RF modules, pulse modules and M-Bus modules) which support an optical IR interface.

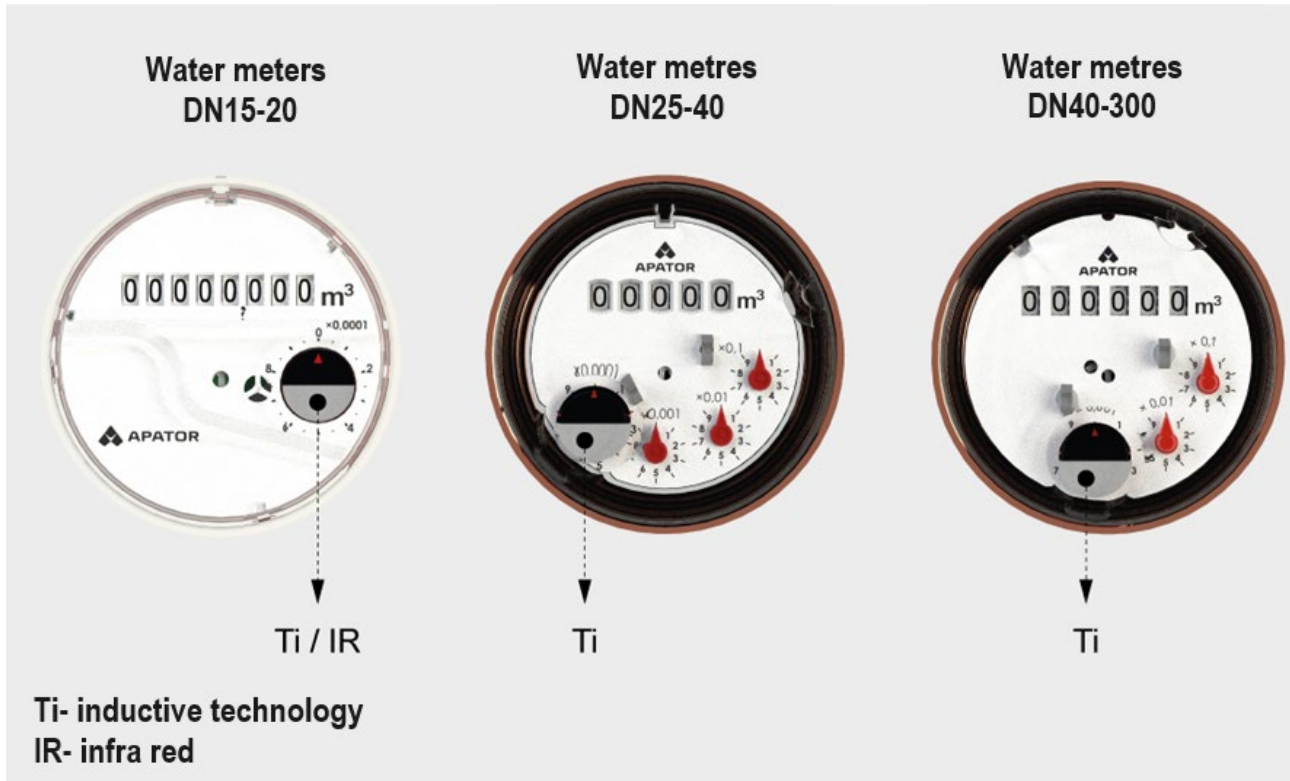

Fig. 4. Compatible data transmission technologies and reading indicator locations

Before installing the module:

- Remove the safety cover from the water meter (if installed).
- Clean the top of the counter mechanism guard (clean the ring recess thoroughly) and the pulse module base which is placed directly over the induction indicator.

Note! Do not use any chemicals, including solvents. Use regular detergents thinned with water.

Keep the module in the storage mode until the installation process begins. In case water meters are transported with modules installed, the storage mode is also recommended.

Exit the module storage mode, after it is installed on a water meter counter. Alternatively, exit this mode on the installation site, which requires deleting errors (disconnect alarm).

7.2. Installation on apartment water meters: JS Smart +; JS Smart C+ and JS Smart D+(DN15 or DN20; T50 or T90) in the IP65/IP68 version

7.2.1 Positioning and fixing the intermediate ring assembly on the counter assembly and checking the installation correctness

1. Position the intermediate ring at the counter guard as shown in the figure below to determine which intermediate ring latches mate with the grooves on the water meter glass panel.

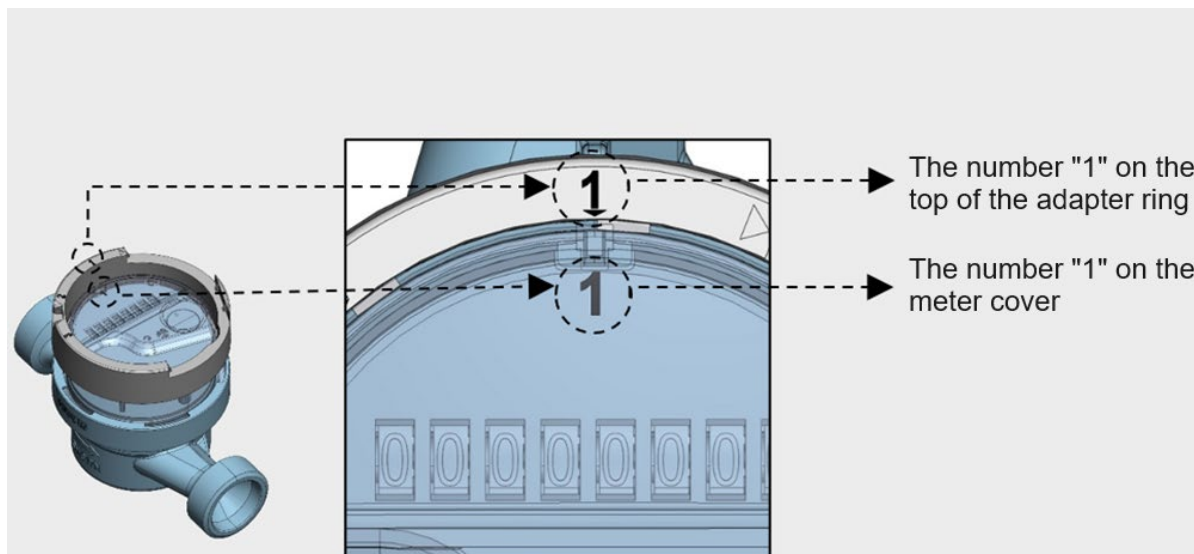

Fig. 5. Correct positioning of the intermediate ring in relation to the counter glass panel

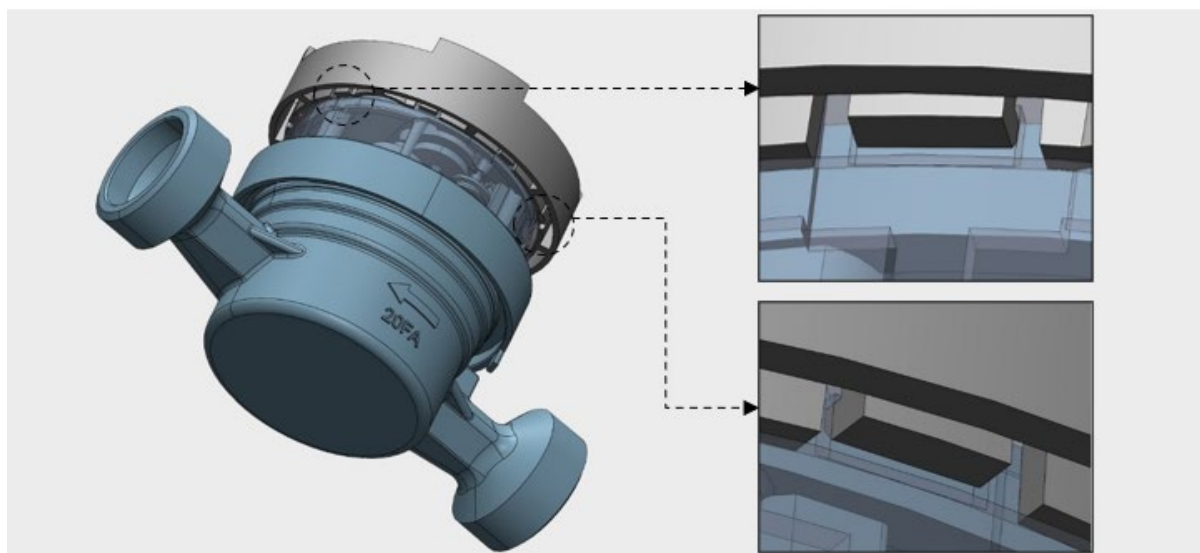

Fig. 6. Three mating latches of the intermediate ring - locations where the locking ring protrusions must be entered

2. Mounting the locking ring* on the intermediate ring

When mounting the locking ring on the intermediate ring, the locking ring must be positioned so that its visible protrusions enter the intermediate ring recesses with latches fixing the ring in mating sockets on the JS Smart water meter counter cover - see Fig. 6.

Note! *The locking ring (33-3160-00007) is used in apartment water meter assemblies (excluding JS Smart D+).

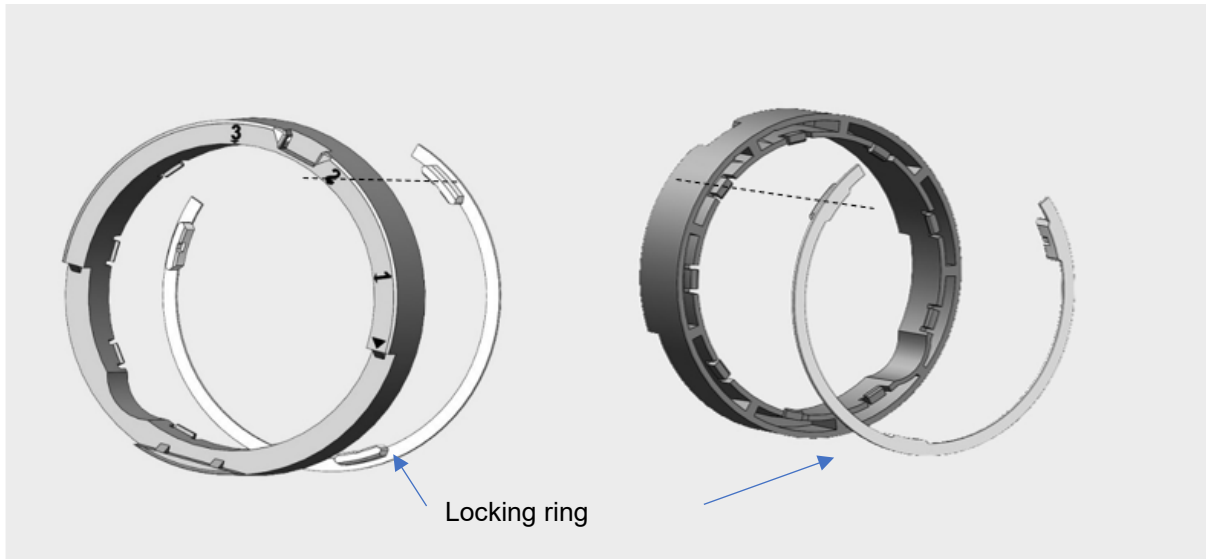

Fig. 7. Positioning the locking ring in relation to the intermediate ring

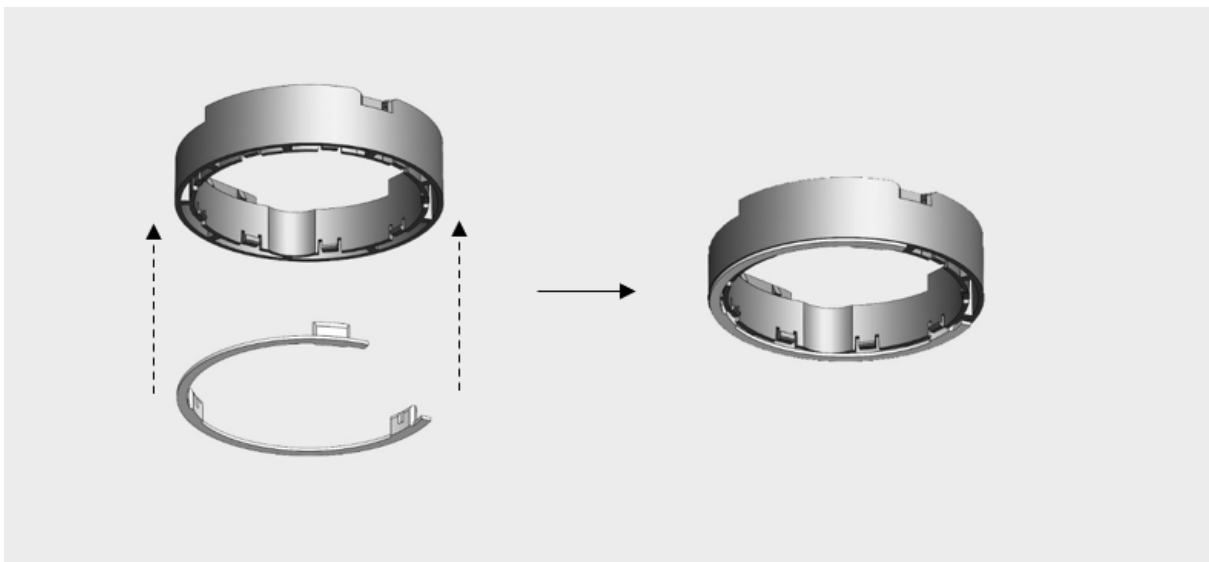

Fig. 8. Mounting the locking ring on the intermediate ring

3. Installation of the pre-assembled intermediate ring + locking ring set on the counter guard should start by positioning the digit “1” on the intermediate ring in relation to the digit “1” on the counter guard. as shown in Fig. 9.

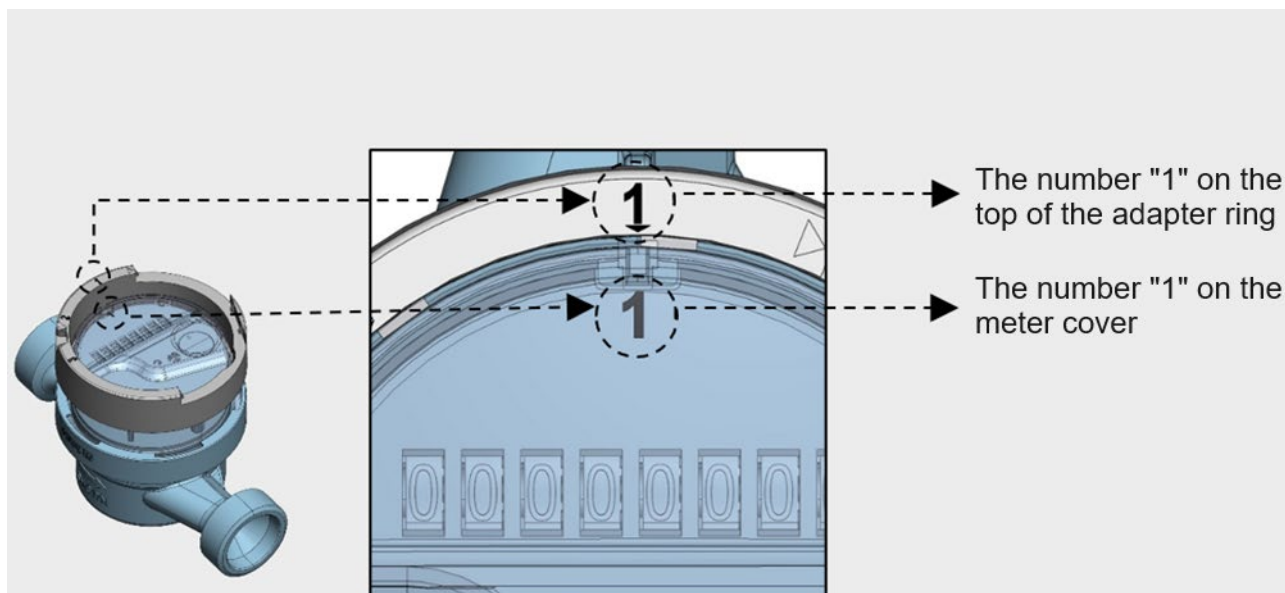

Fig. 9. Positioning the intermediate ring on the counter guard

4. While performing the actions described in sections 3, adjust the position of the intermediate ring latches in relation to the arrangement of mounting holes on the cylindrical part of the water meter counter guard.

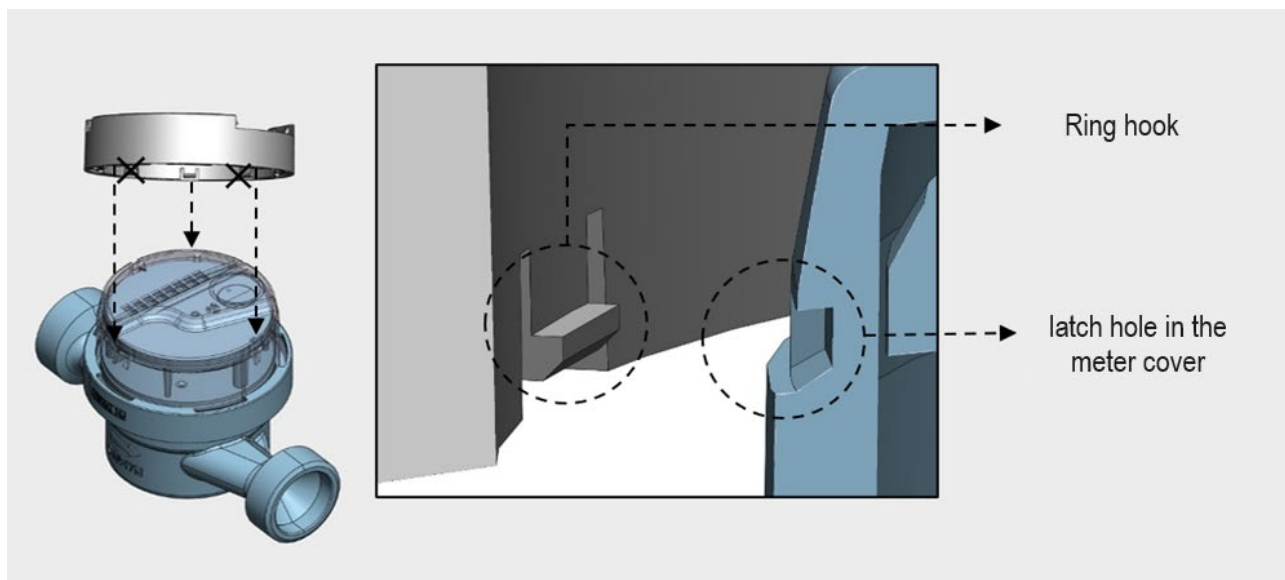

Fig. 10. Intermediate ring catches matching the recesses on the cylindrical part of the water meter counter

5. After completing the activities described in section 2 and 3, use both hands to press down the intermediate ring firmly on the counter guard until a “click” is heard.

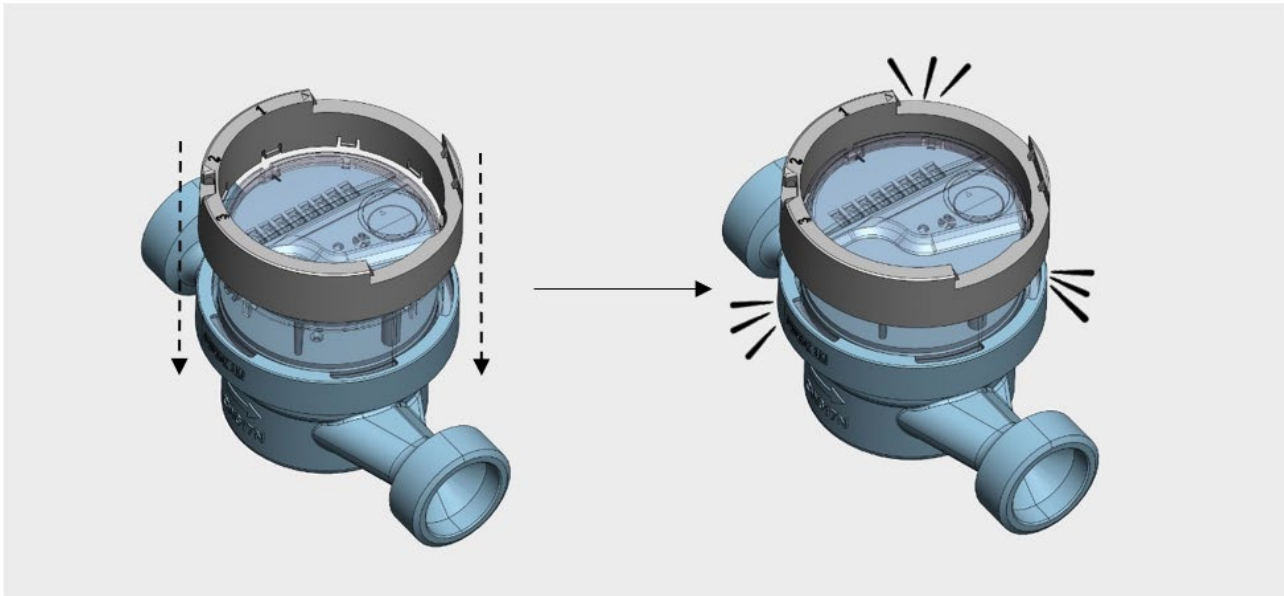

Fig. 11. Pressing the intermediate ring to the cylindrical part of the water meter counter

6. Try to pull away the intermediate ring to verify its attachment.

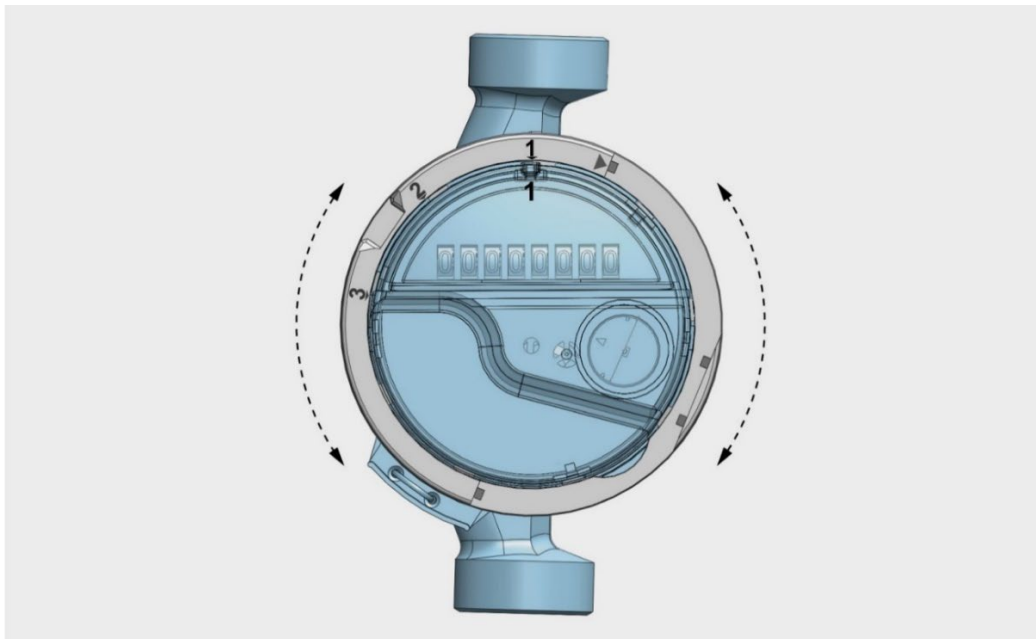

Fig. 12. Test without forcible disassembly of the intermediate ring from the cylindrical part of the water meter counter

7.2.1. Transmission module installation

1. Position the transmission module over the intermediate ring secured on the counter guard so that the “1” mark on the module side wall is over the “Δ” mark on the top edge of the intermediate ring.

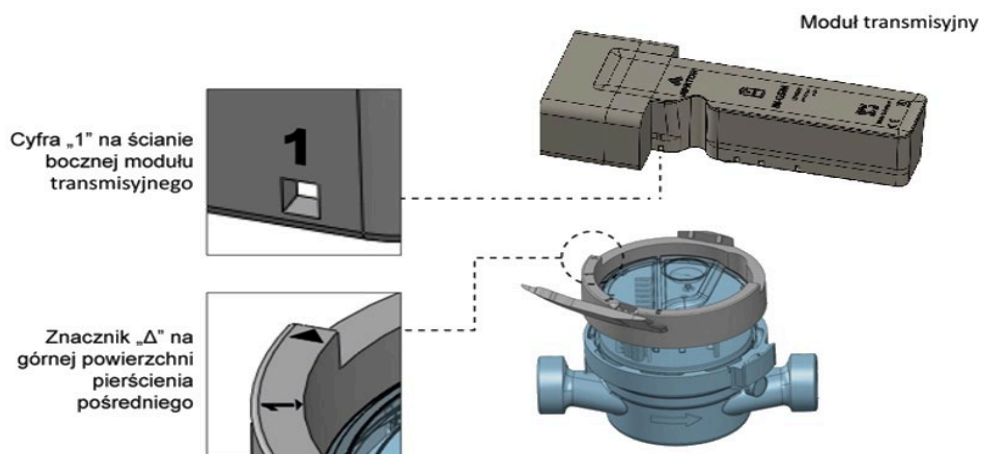

Fig. 13. Installation of the IN-GSM inductive transmission module on the water meter mechanism

2. Insert the transmission module into the intermediate ring recess on one side, so that two latching tabs of the intermediate ring (A) are inserted into two latching holes of the module, then press the module from the top to the ring so that the latches on the opposite side of the ring (B) are engaged.

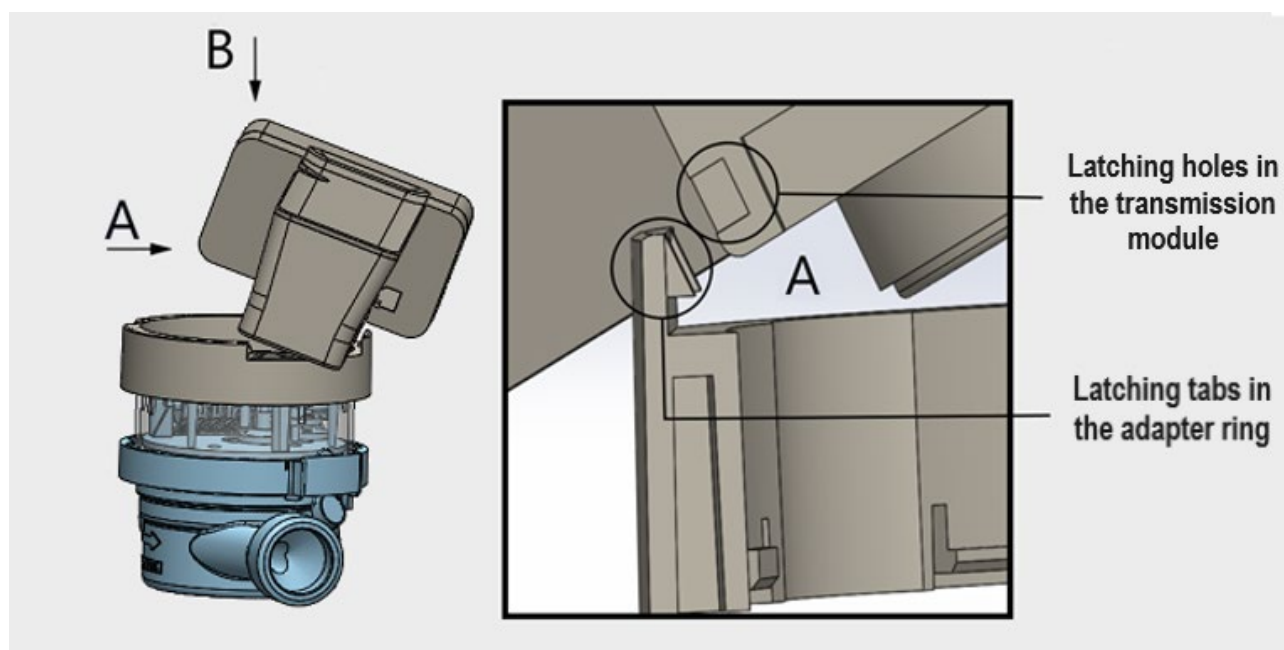

Fig. 14. Latching the IN-GSM inductive module on the intermediate ring

3. Use both hands to firmly press down the opposite side of the module into the intermediate ring and engage the two remaining latching holes on the opposite module wall (loud “click”).

4. Try to forcibly dismount the intermediate ring with the module to verify their attachment. Then install the safety cover on the intermediate ring.

5. This completes the installation process.

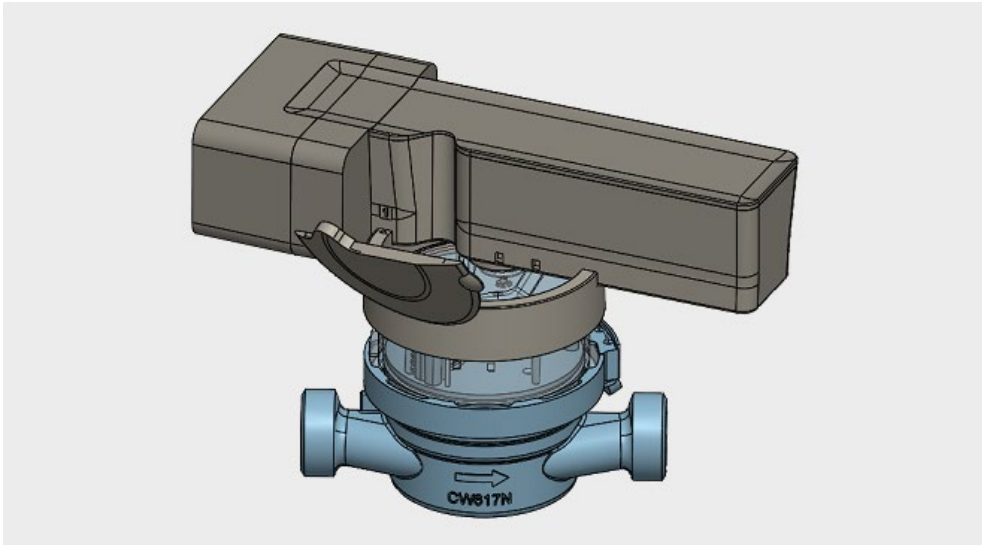

Fig. 15. IN-GSM inductive module correctly installed on an apartment water meter

Installing a GSM module as per the procedure described above ensures its correct operation. The separable fastening of the module and mounting ring facilitates trouble-free replacement of individual metering point components, as required.

7.3. Installation on a house water meter, type JS Master +, JS Master C+ and JS Master D+(DN25 – DN40; T50 or T130) in the IP65 version

Generally, the IN-GSM module for JS Master series water meters is installed in the same way as for JS smart series water meters, as described in section 7.2. However, the differences in the installation procedure for the intermediate ring + locking ring assembly are described in the following section.

7.3.1. Positioning and fixing the intermediate ring assembly on the counter assembly and checking the installation correctness

1. Position the intermediate ring at the counter guard as shown in the figure below to determine which intermediate ring latches mate with the sockets on the counter side.

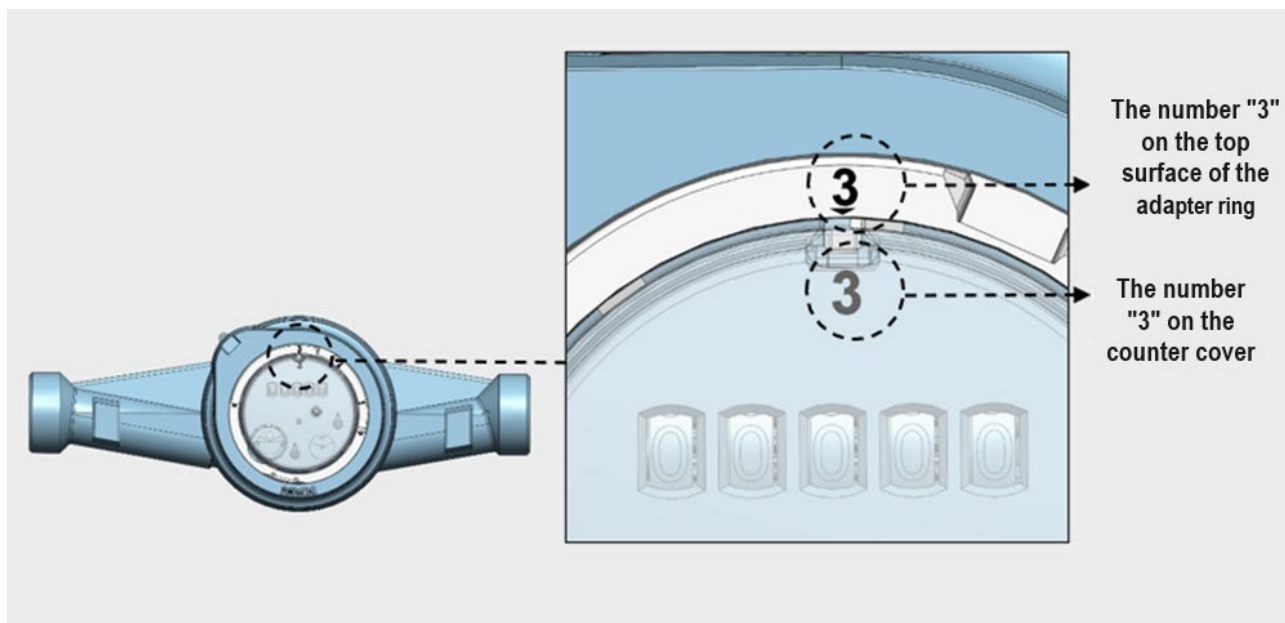

Fig. 16. Correct positioning of the intermediate ring in relation to the counter guard

2. Mounting the locking ring on the intermediate ring

Install the locking ring on the intermediate ring in line with the method specified in Figures 17 and 18 (below). Particular attention should be paid to positioning the locking ring in such a way that its protrusions are placed in those intermediate ring recesses in which there are latches fixing the ring in corresponding sockets on the JS Master water meter counter cover, which is visible when placing the module at the counter guard - see Fig. 17.

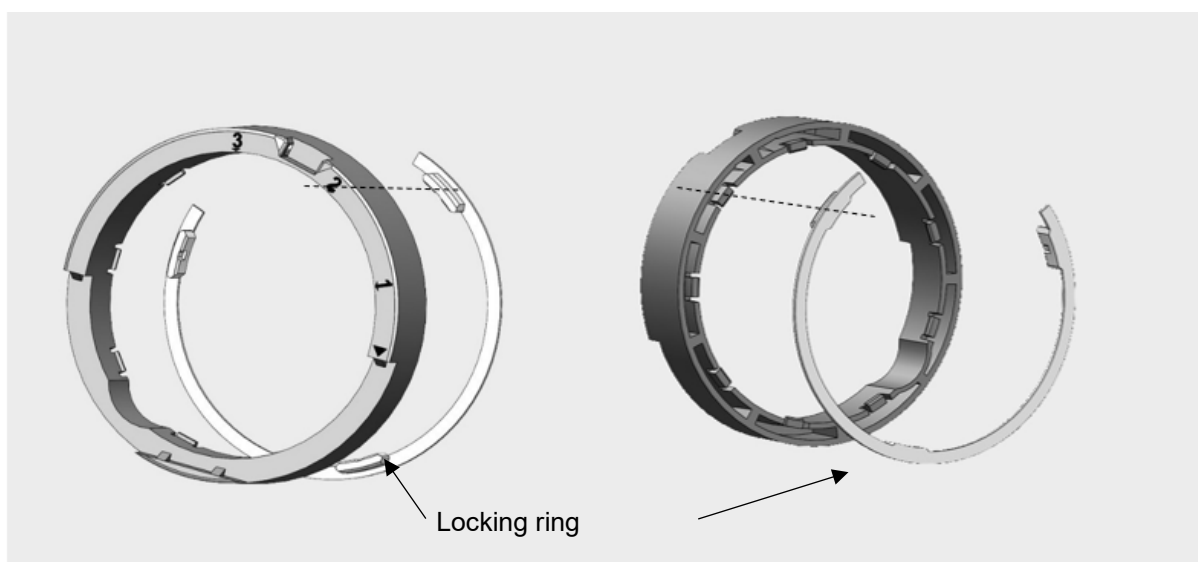

Fig. 17. Positioning the locking ring before intermediate ring installation

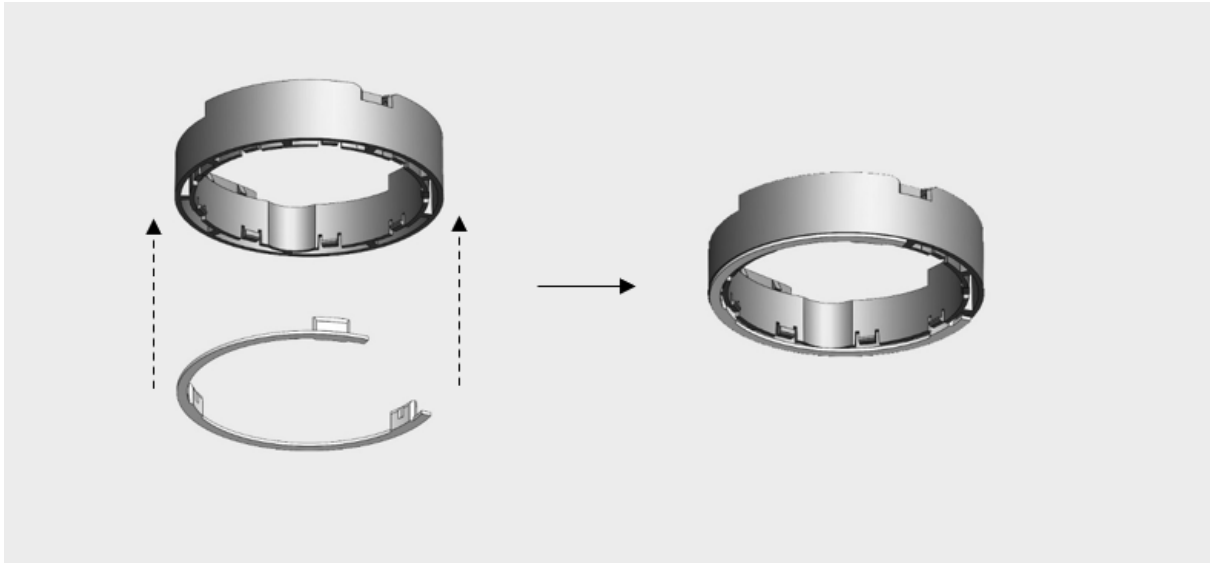

Fig. 18. Mounting the locking ring on the intermediate ring

3. Install the intermediate ring + locking ring assembly on the water meter counter guard by placing the intermediate ring at the water meter counter guard in such a way that the “3” digit located on the upper edge of the intermediate ring is directly above the “3” mark visible on the water meter counter guard. While performing the actions described in sections 3, adjust the position of the intermediate ring latches in relation to the arrangement of mounting holes on the cylindrical part of the water meter counter guard.

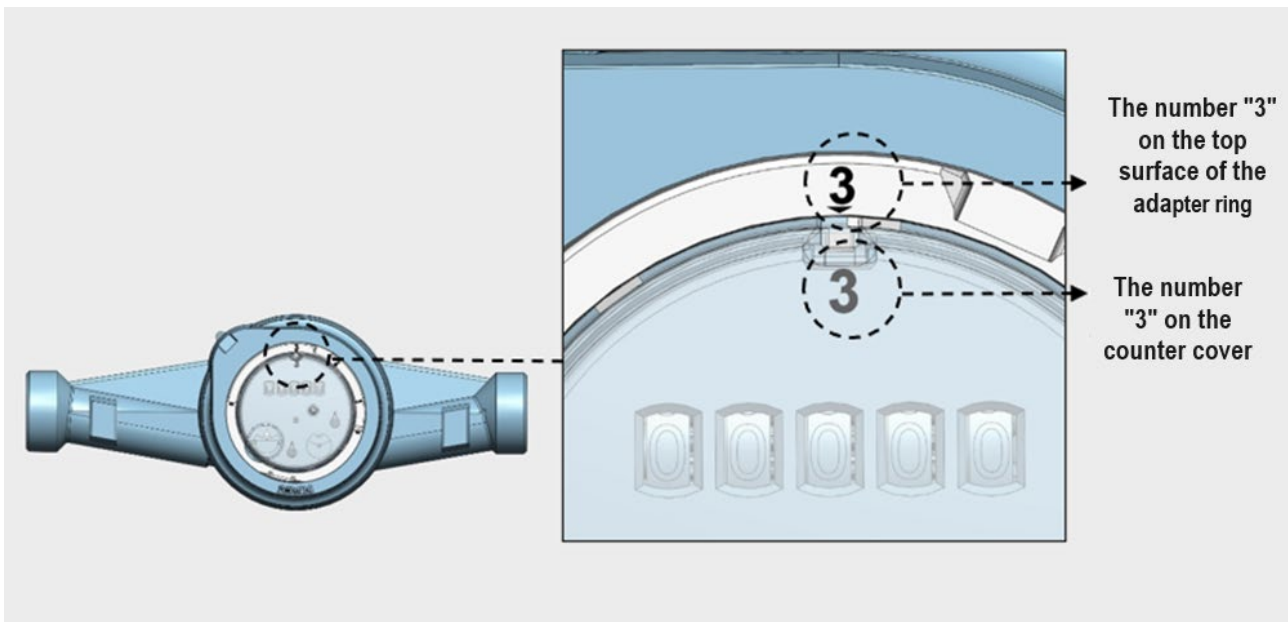

Fig. 19. Intermediate ring installation on the JS Master + water meter counter guard

4. Use both hands to press down the intermediate ring firmly on the water meter counter guard until a loud “click” is heard.

5. Try to pull away the intermediate ring sub-assembly to verify its attachment.

7.3.2. Transmission module installation

1. Position the module over the intermediate ring secured on the counter guard so that the “2&3” mark on the module side wall is over the “Δ” mark on the top edge of the intermediate ring.

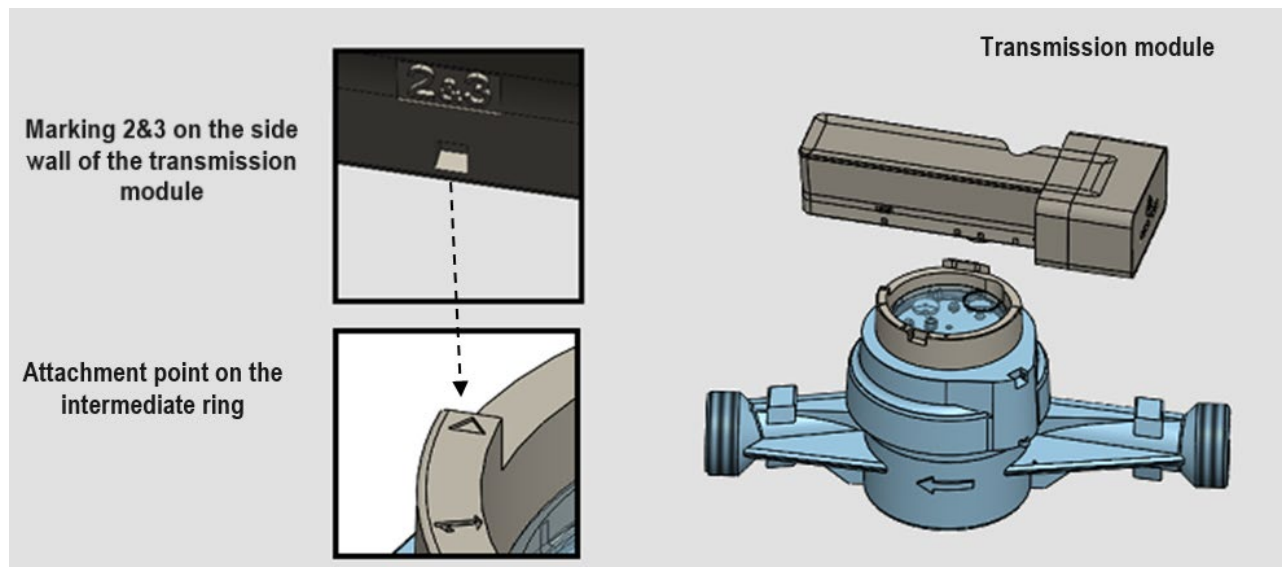

Fig. 20. Positioning the IN-GSM inductive module over the intermediate ring

2. Insert the transmission module into the intermediate ring recess on one side, so that two latching tabs of the intermediate ring (A) are inserted into two latching holes of the module, then press the module from the top to the ring so that the latches on the opposite side of the module (B) are engaged.

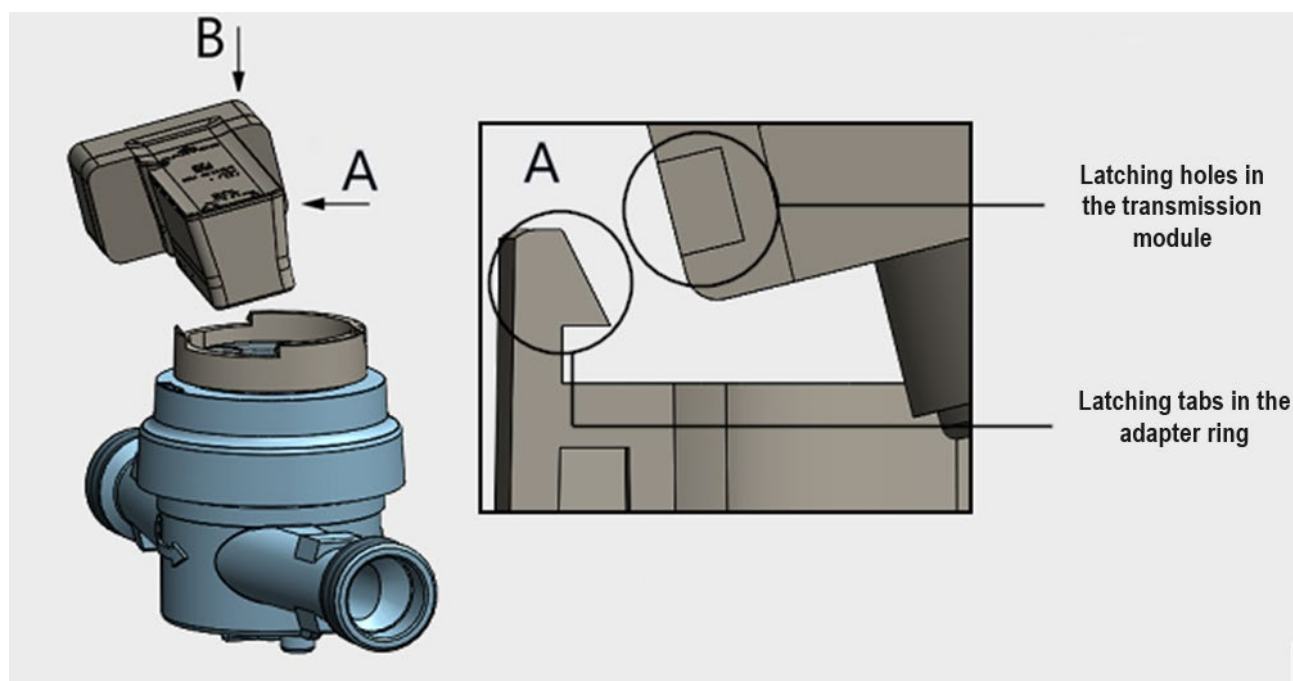

Fig. 21. IN-GSM inductive module installation on the mounting ring

3. Try to forcibly dismount the intermediate ring with the module to verify their attachment. Then install the safety cover on the intermediate ring.

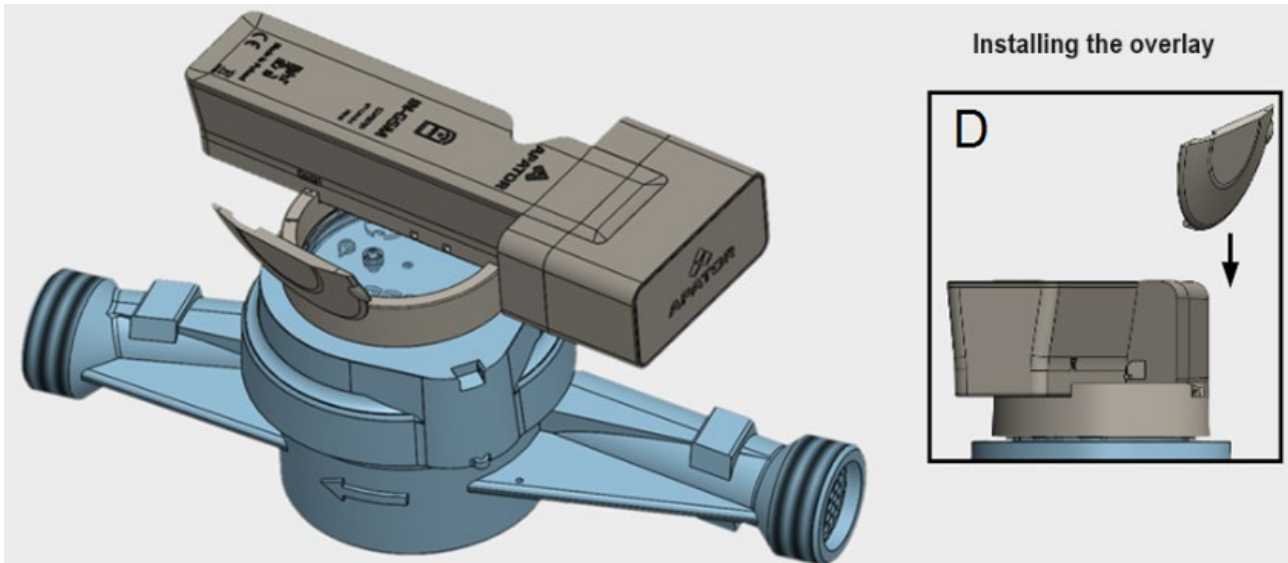

Fig. 22. IN-GSM inductive module correctly installed on a house water meter

4. This completes the installation process.

7.4. Installation on a house water meter, type JS Master (DN25 – DN40; T50), in the IP68 version

1. The JS Master water meter in IP68 version is standard equipped with a special counter guard with a #UTIP (Universal TI Plug) used for communication module installation. Remove the cover before installing the communication module.



Fig. 23. JS Master water meter in the IP68 version without cover

2. Position the IN-GSM module over the counter guard intermediate ring so that the “2&3” mark on the module side wall is over the latch (shown below) in the counter guard intermediate ring.

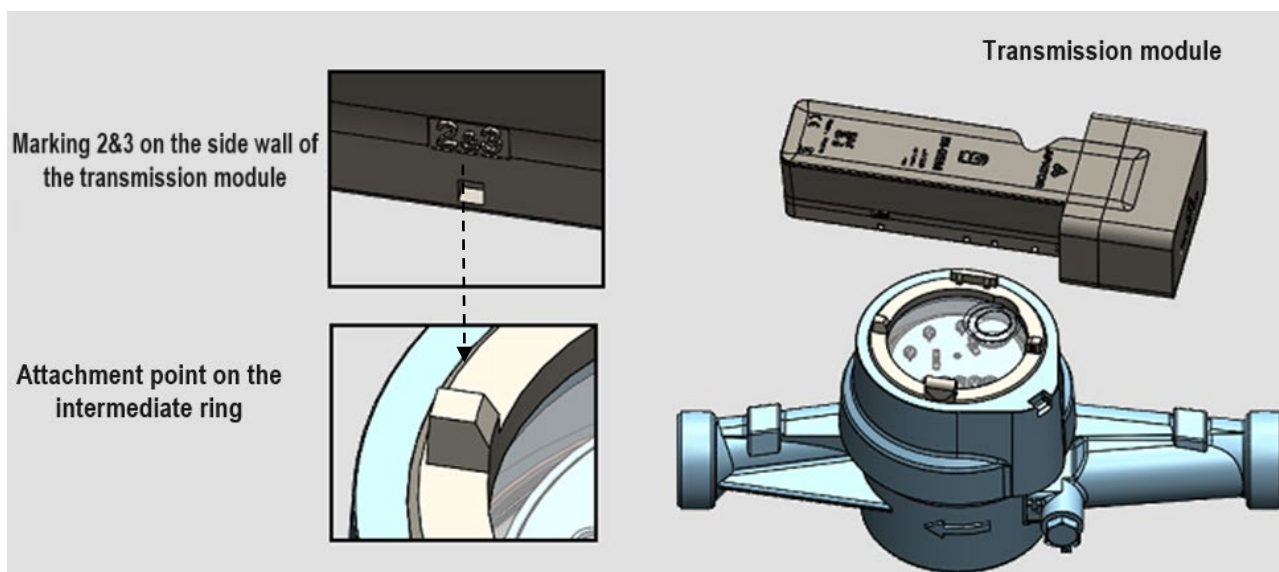

Fig. 24. Positioning the IN-GSM inductive module over the counter guard intermediate ring

3. Insert the module into the intermediate ring recess on one side, so that two latching tabs of the intermediate ring (A) are inserted into two latching holes of the module, then press the module from the top to the ring so that the latches on the opposite side of the ring (B) are engaged.

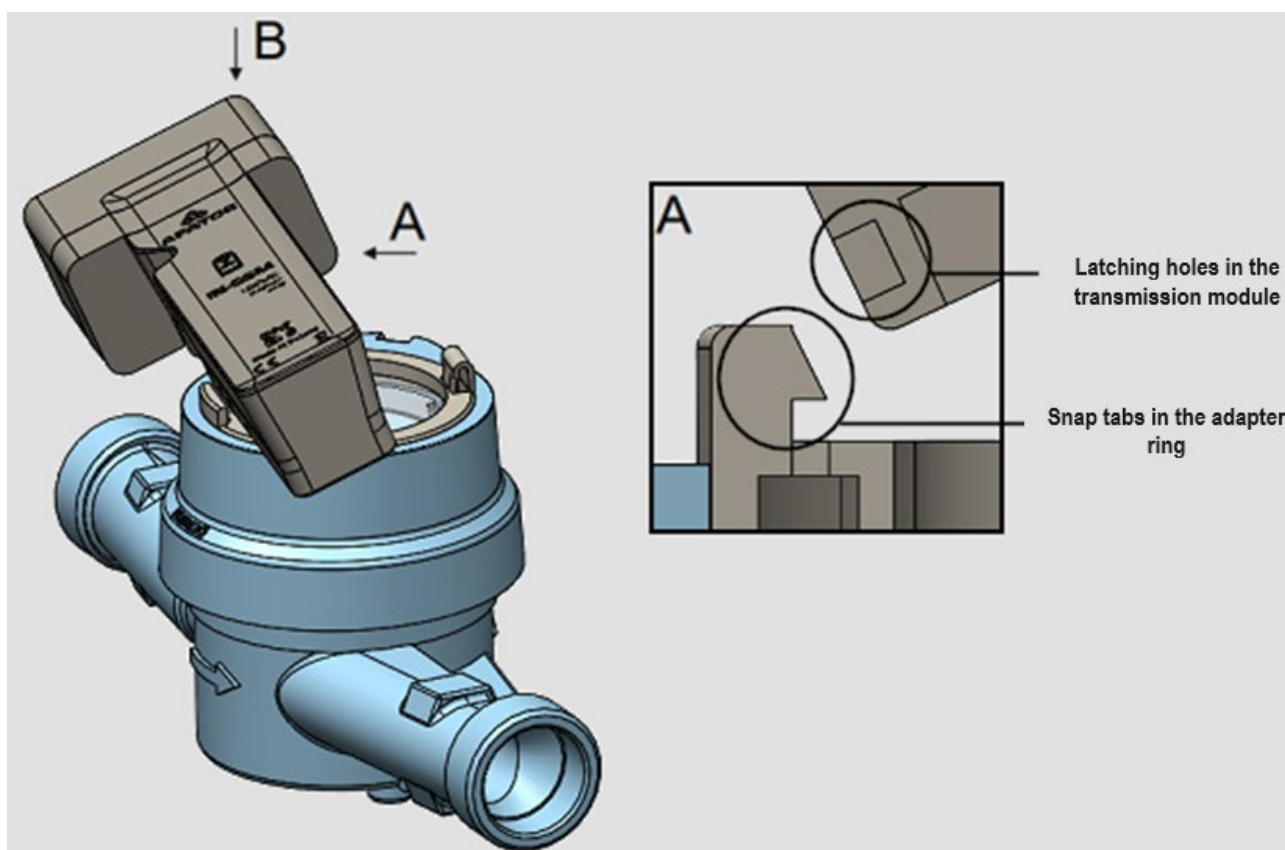

Fig. 25. IN-GSM inductive module installation on the water meter guard intermediate ring

4. Install the ring lock (C) and check if the IN-GSM module is mounted correctly by testing it without forcible removal, and then install the cover (D) covering the counter barrels.

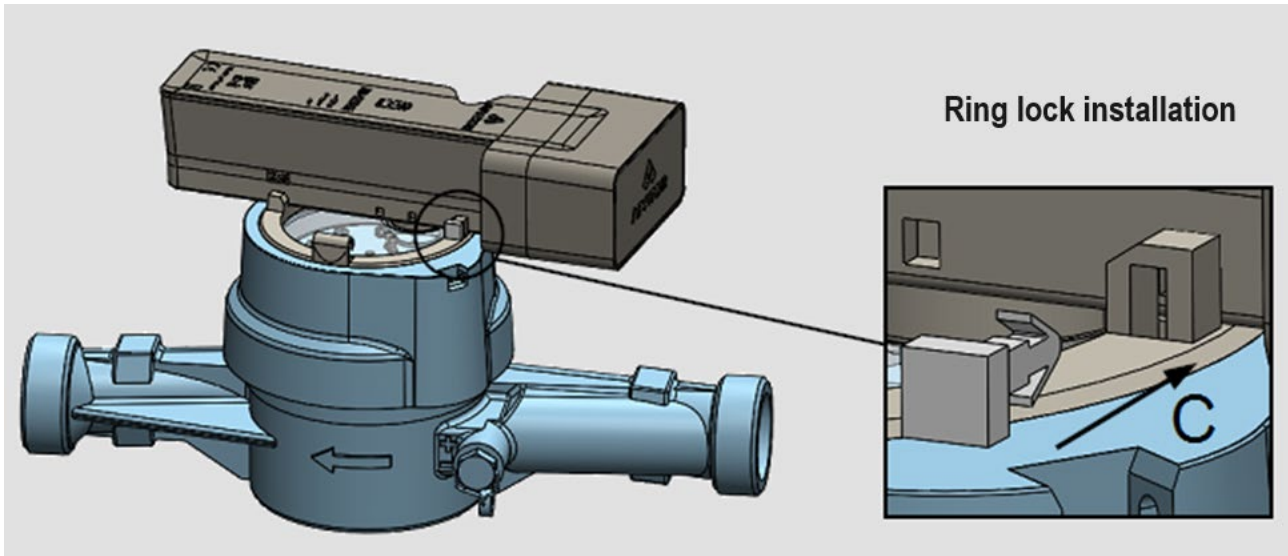

Fig. 26. IN-GSM inductive module installed on a house water meter with the ring lock installed

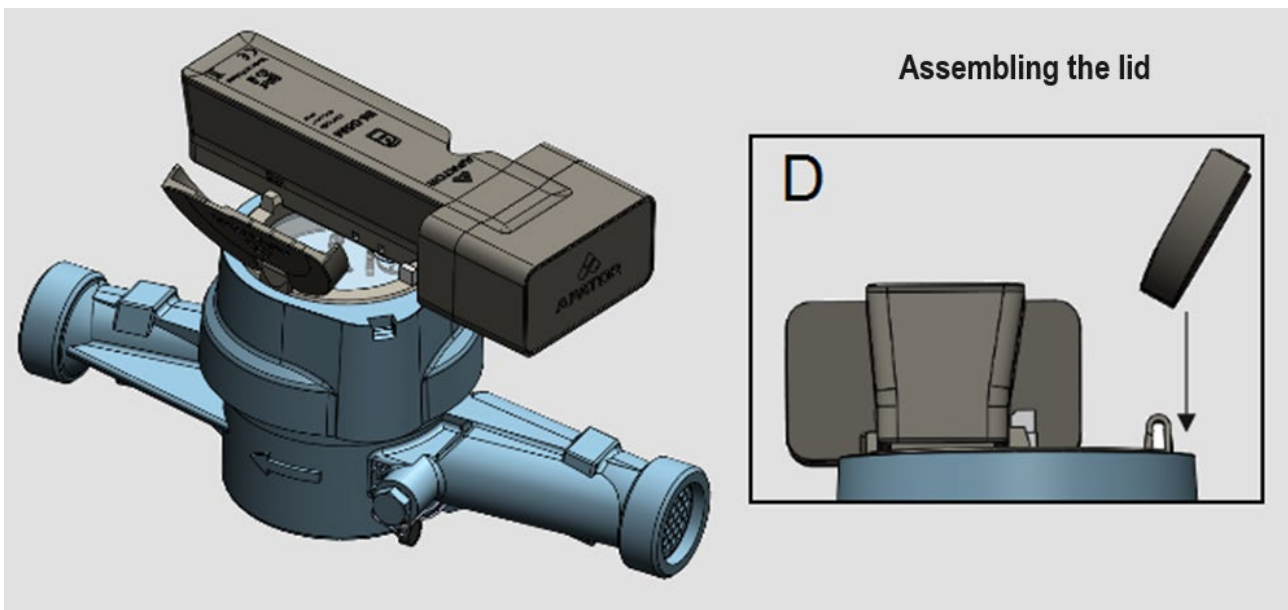

Fig. 27. IN-GSM inductive module correctly installed on a house water meter

5. This completes the installation process.

7.5. Installation on industrial water meters type MWN (T50 or T130), JS(T50), MK (T50), IP65 version

1. Industrial water meter type MWN in IP65 version The transmission module installation process in other types of industrial water meters (JS; MK) is similar. Remove the cover from the intermediate ring. Mount the intermediate ring on the water meter counter guard so that the “2” mark on the top edge of the mounting ring

is located directly over the “2” mark on the water meter counter guard. Use both hands to press down the mounting ring firmly on the water meter counter until a loud “click” is heard.

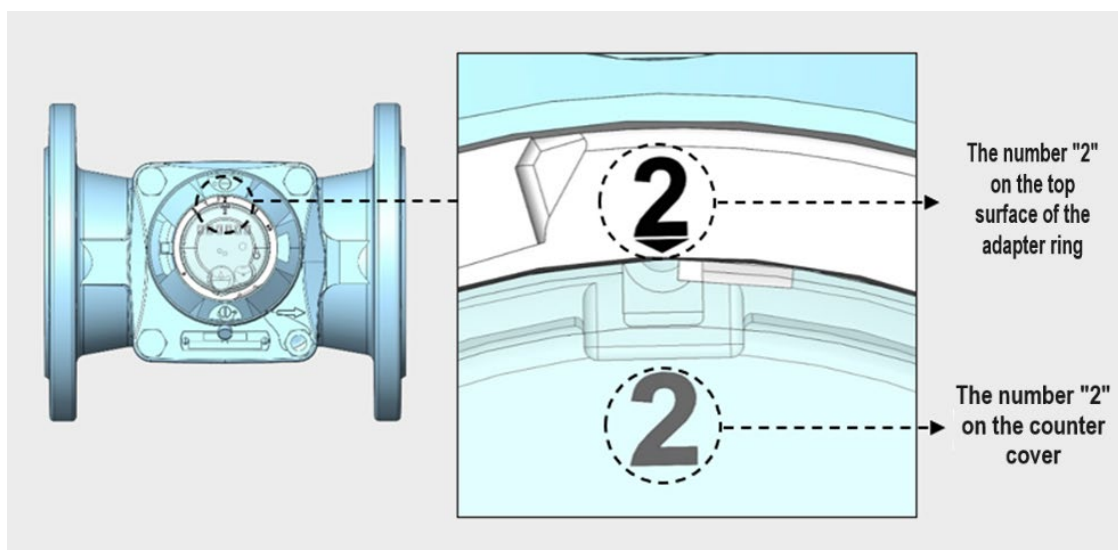

Fig. 28. Fastening the intermediate ring on the counter guard

2. Position the transmission module over the intermediate ring secured on the counter guard so that the “2&3” mark on the module side wall is over the “Δ” mark on the top edge of the intermediate ring.

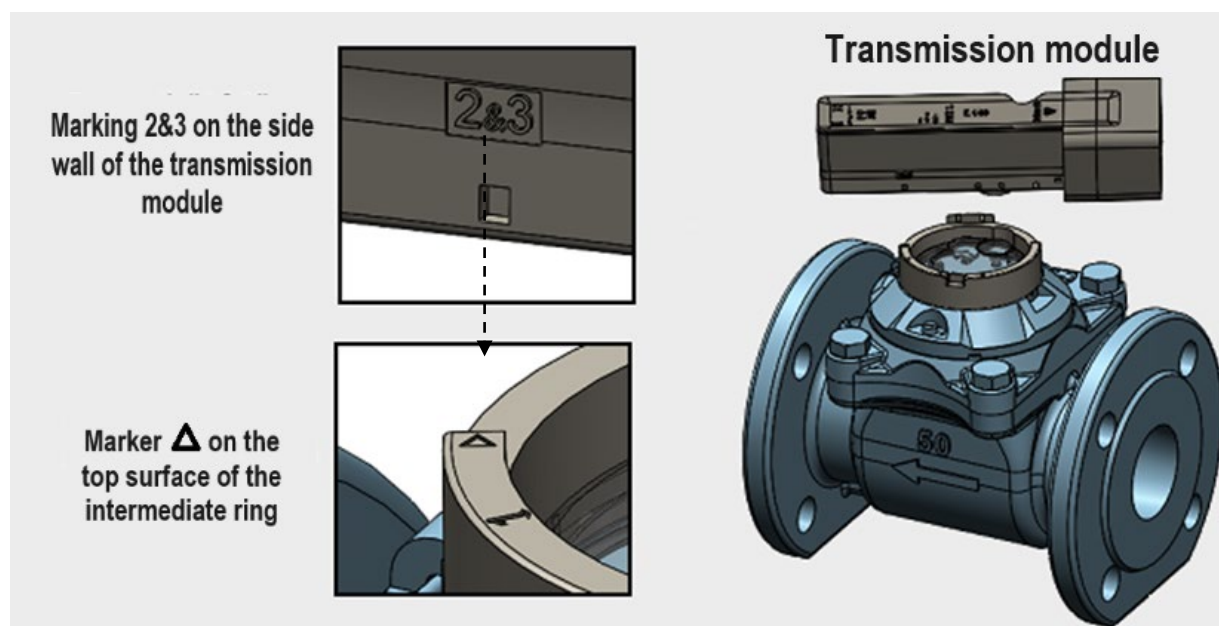

Fig. 29. Positioning the inductive module on the intermediate ring

3. Insert the module into the intermediate ring recess on one side, so that two latching tabs of the intermediate ring (A) are inserted into two latching holes of the module, then press the module from the top to the ring so that the latches on the opposite side of the ring (B) are engaged.

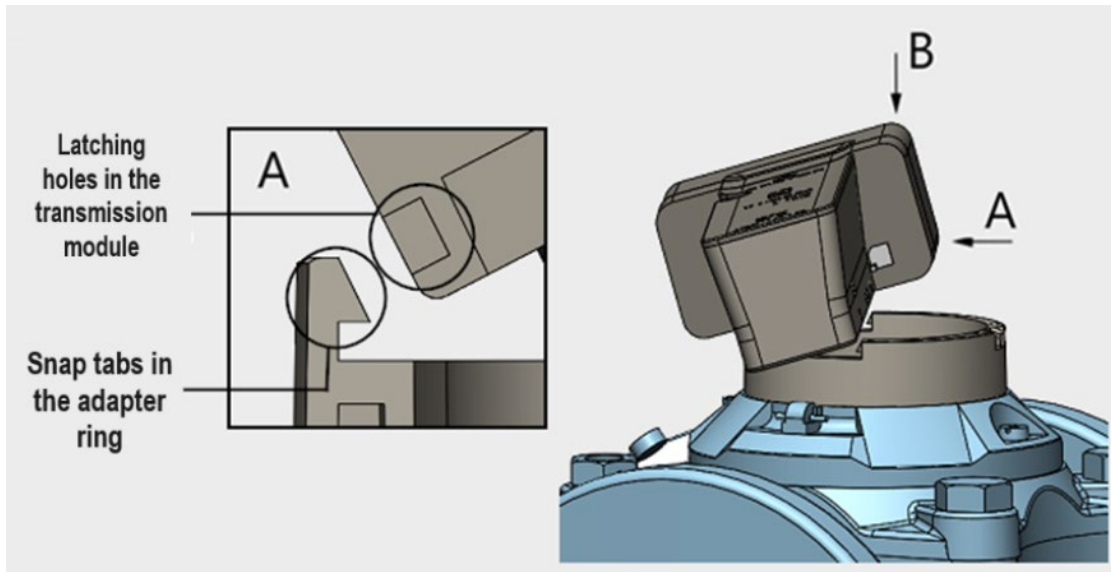

Fig. 30. IN-GSM inductive module positioning on the intermediate ring

4. Try to forcibly dismount the intermediate ring with the module to verify their attachment and install the cover (D) securing the counter barrels.

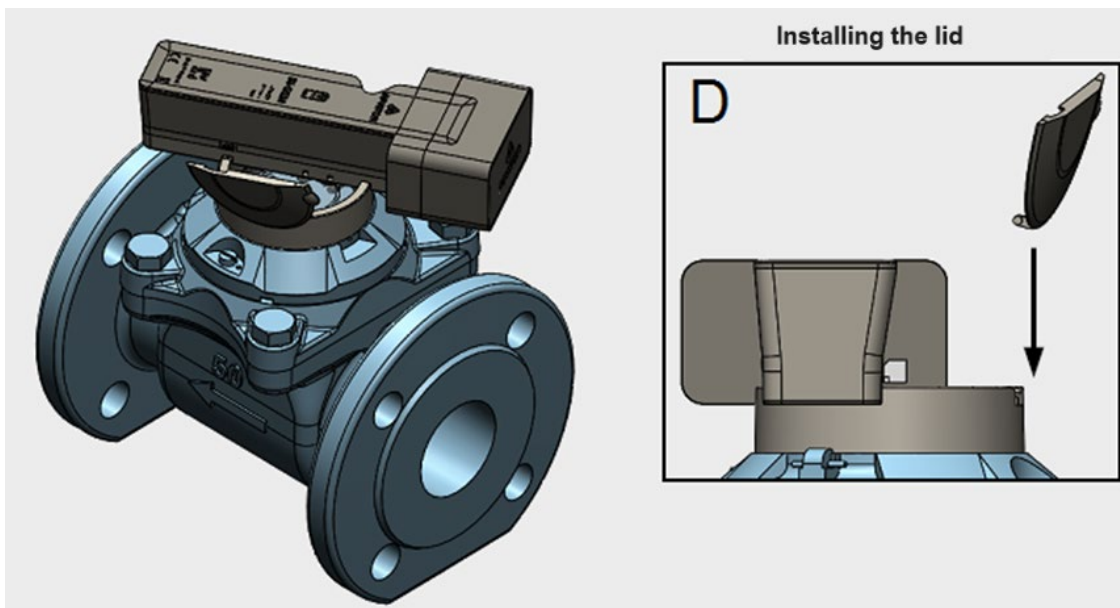

Fig. 31. IN-GSM inductive module correctly installed on an industrial water meter

7.6. Installation on industrial water meters type MWN (T50), JS (T50), MK (T50), IP68 version

1. Industrial water meter type MWN in IP68 version which is standard equipped with a special counter guard with a #UTIP (Universal TI Plug) connector used for transmission module mounting. The transmission module installation process in other types of industrial water meters (JS; MK) is similar. Before installing the module, remove the water meter guard cover.

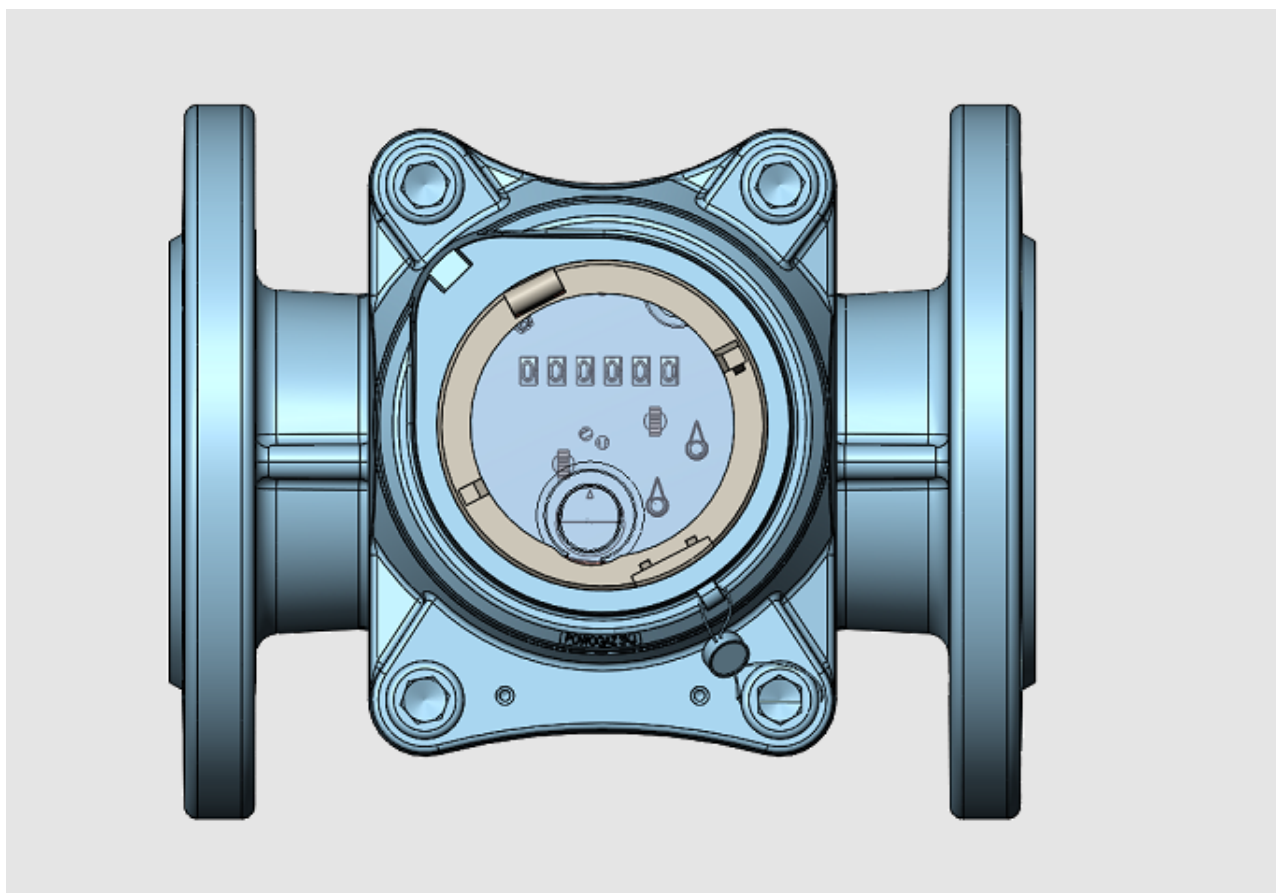

Fig. 32. MWN industrial water meter in IP68 version

2. Position the IN-GSM transmission module over the water meter guard intermediate ring so that the “2&3” mark on the module side wall is over the latch (shown below) in the intermediate ring.

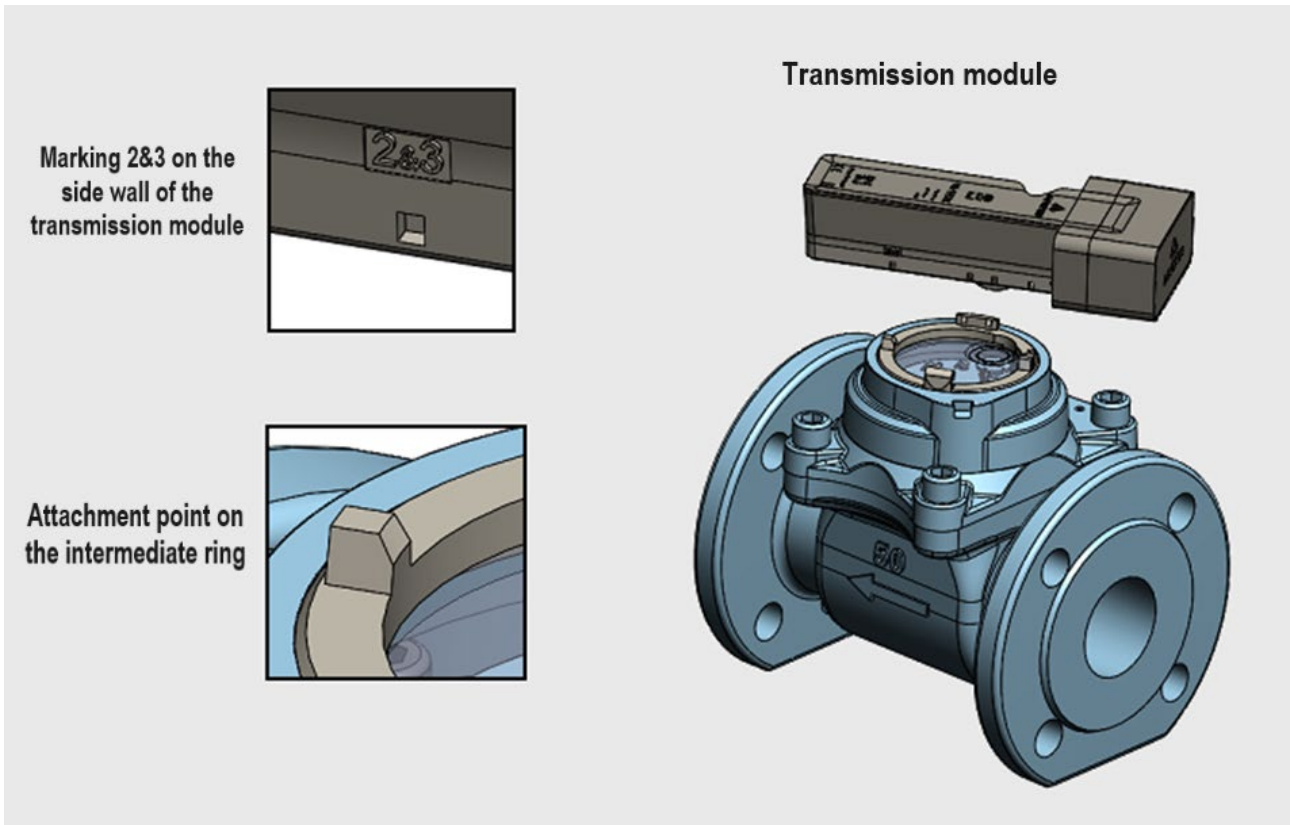

Fig. 33. IN-GSM inductive module positioning on the counter guard

3. Insert the transmission module into the water meter guard intermediate ring recess on one side, so that two latching tabs of the intermediate ring (A) are inserted into two latching holes of the module, then press the module from the top to the ring so that the latches on the opposite side of the ring (B) are engaged.

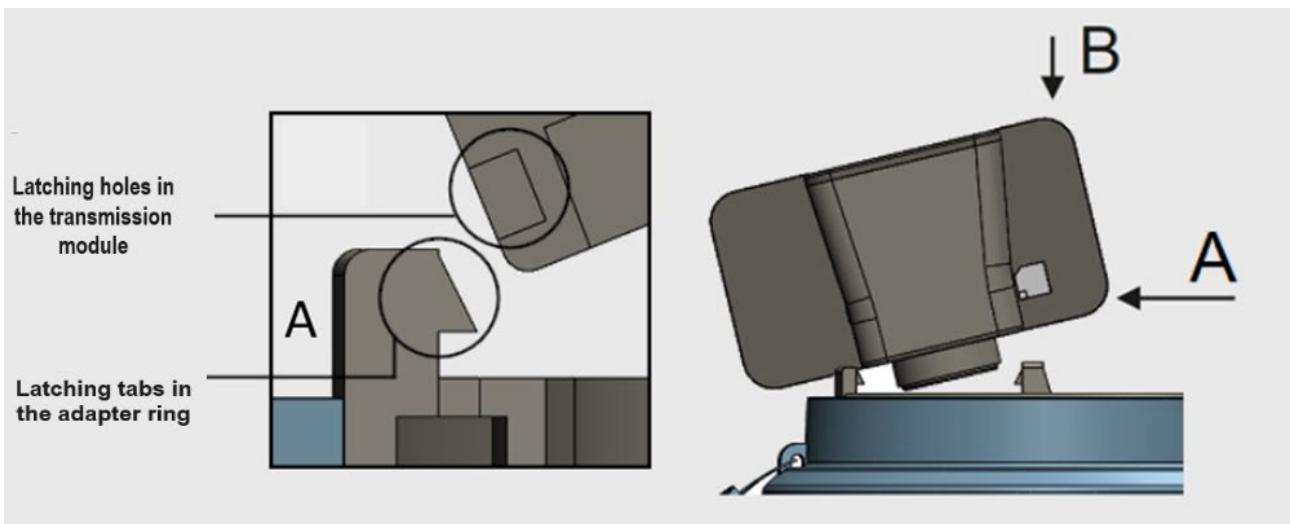

Fig. 34. IN-GSM inductive transmission module installation on the intermediate ring

4. Install the ring lock (C) and check if the IN-GSM module is mounted correctly by testing it without forcible removal, and then install the cover (D) covering the counter barrels.

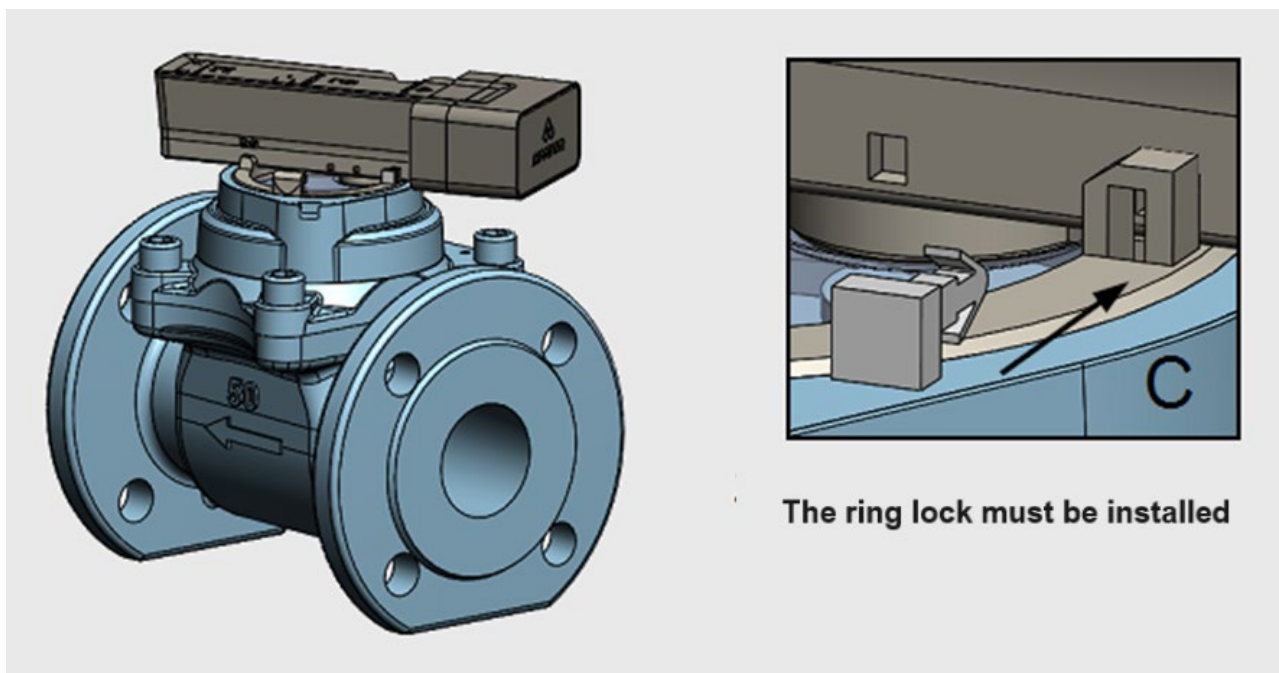

Fig. 35. IN-GSM inductive module installed on an IP68 industrial water meter and locking pin installed

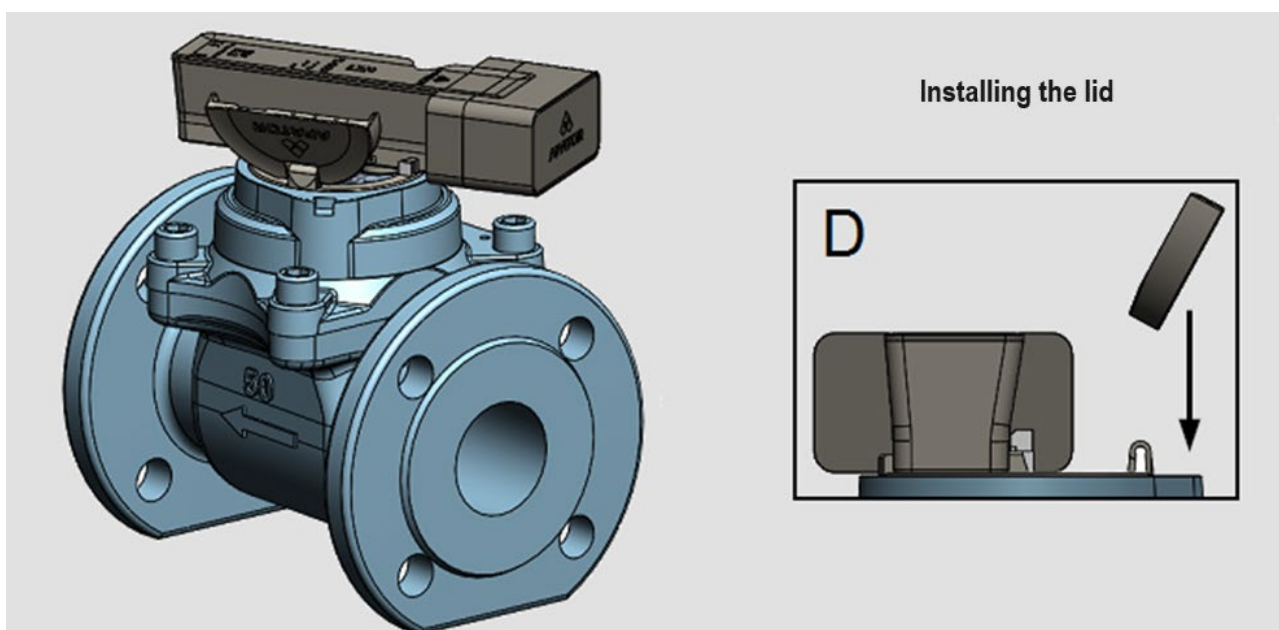

Fig. 36. IN-GSM inductive module correctly installed on an MWN industrial water meter, IP68 version

7.7. Installing an external antenna

Install the external antenna as shown in the figure below:

- The antenna cable must be secured to fixed parts inside the water meter well (pipe or wall) with standard fasteners (zip ties, pins, etc.).
- Never secure the antenna or its components (e.g. the cable) to a water meter well access ladder or steps or apply any similar solutions.

- Coil the slack antenna cable length with a diameter above 20 cm and fasten it to a fixed part near the module. Secure the antenna cable against kinks.
- The cable bending radius must be at least 10 cm.
- Keep the antenna cable at least 15 cm away of all metal parts.
- The antenna holder must be fastened less than 1 cm from the antenna tips.

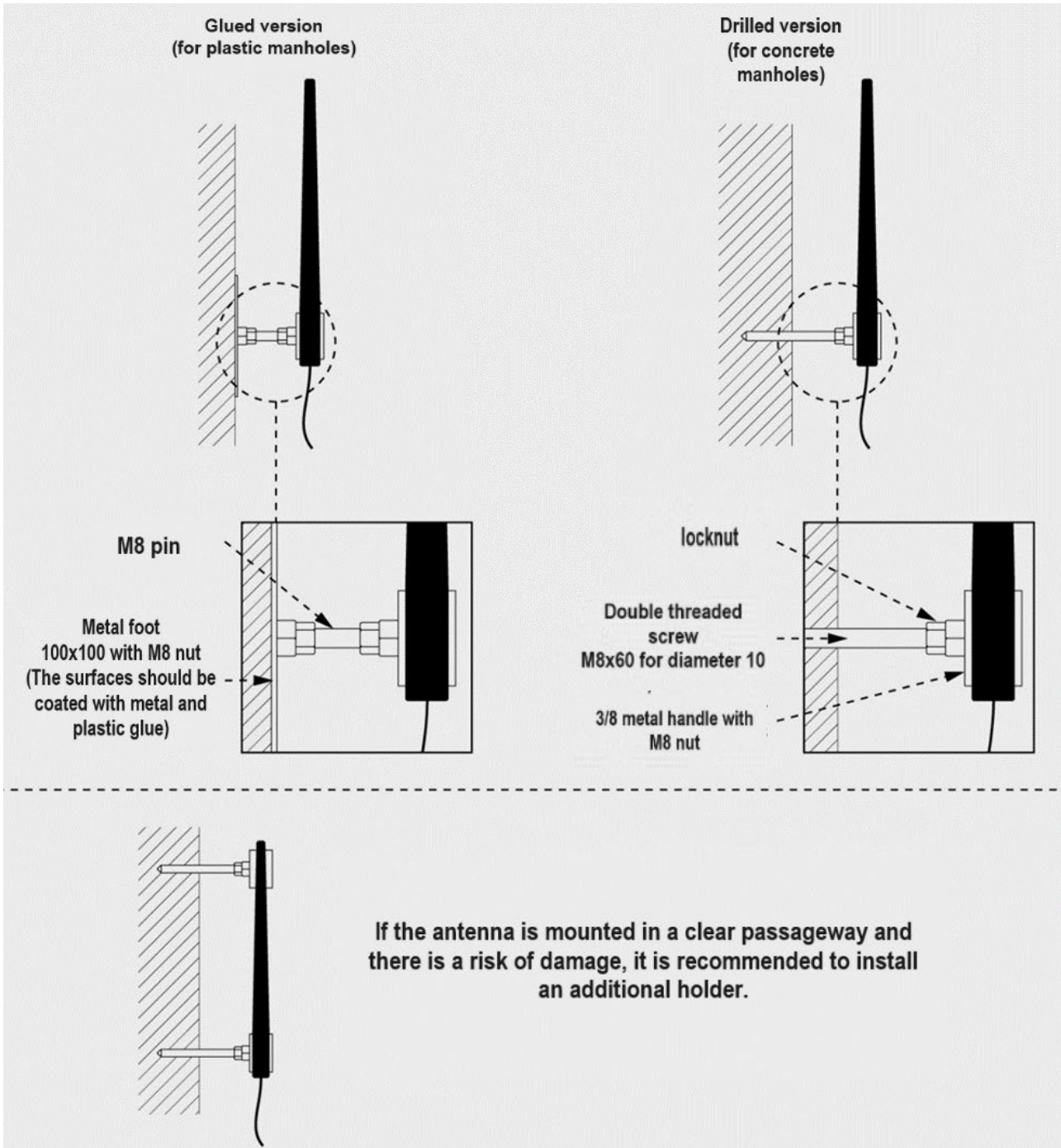

Fig. 37. External antenna installation options

7.8. Configuration

Modules can be configured and data can be read out only using SPIDAP Mobile and Web applications.

7.8.1. Exiting the storage mode

The storage mode can be cancelled using NFC communication. When a phone is placed at the transmission module and the module itself is detected, the device CPU is activated. Cancelling the storage mode requires starting the main module program, which takes approx. 10 - 12 seconds. Only after this time, the module will be able to communicate in the normal operation mode. If the module does not exit the storage mode, place the phone next to it, again.

Note! If after starting the main program, the module does not receive a storage mode exit command, after 20 seconds it goes again to this mode.

Note! With software updates, the main module program start-up time may be shorter or slightly longer.

7.8.2. Configuration of module with water meter

After installing the device on the water meter, configure the module by entering the data into the SPIDAP Mobile application accordingly. The user application recalculates the entered values and saves them to the device registers:

- Device type selection
- Tasks (profile recording or battery replacement)
- Water meter profile selection
- Water meter number
- Water meter indication
- APN name (default - iot.1nce.net - SIM card supplier)
- APN user (leave the field empty)
- APN password (leave the field empty)
- Server address
- Phone number for binary data
- Phone number for text data
- Time zone selection
- Summer/winter time
- Downloading date and current time from a phone

7.8.3. Counter calibration

The device detects water meter revolutions and saves their number in the volume register.

Metering system auto-calibration is performed automatically at the first start-up of the device installed on a water meter. It is done after counting the number of forward indicator revolutions. Next, the water meter volume and/or events are reset (depending on the device configuration).

7.9. Operation

7.9.1. Data readout

The device is equipped with a four-band GSM 2G modem, thanks to which it can communicate via GPRS package transmission or text messages.

7.9.2. Local readout

The transmission module comes with an NFC communication interface facilitating communication with it using a mobile device with the SPIDAP Mobile software.

7.9.3. Remote readout

The transmission module sends, via the GSM network, the data read out from the water meter to the server from which a user can download it. In addition, the person responsible for a given metering area may receive an emergency text message on his/her phone, with information concerning an event requiring immediate action.

7.9.4. Event alerts and alarms

Events are recorded in the event recorder, which, apart from specific event occurrence, also records the associated details which are related to a given event type.

In addition, events are recorded in the form of flags indicating the current event duration and its past occurrence.

Events can be divided into 3 groups:

- water meter-related events;
- system-related events;
- service-related alarms.

Event-related GPRS transmissions are not limited, and they are counted by the global transmission counter. Their number has a significant impact on the battery life, and using this functionality reduces the number of possible scheduled transmissions.

Events defined as alarms result in sending an emergency text message, regardless of the text message activation flag setting.

After an event occurs and a text message is sent, this message is sent again for an event of the same type only when the user deletes the event flags or deletes the entry corresponding to this event from the register. Event-related transmissions have a similar effect.

Note! In case simultaneous multiple events for which sending a text message has been configured occur, the device sends messages related to the first 3 events. Subsequent events may be omitted if events occur so quickly that it is impossible to send subsequent text messages.

Alarms

The device treats the following events as alarms:

- leaks;
- maximum flow;
- magnetic field detection;
- detection of disconnection of the module from the water meter;
- exceeding the minimum operating temperature;
- exceeding the maximum operating temperature.

In addition to actions performed for each event, in the case of alarms, the details of each occurrence and completion are recorded in the alarm recorder. Transmissions and text messages related to alarms are set up in the same manner as event-related elements.

Service alarms

These alarms do not trigger a transmission or text message, but are only recorded in the service alarm recorder. For example, they record activities which change data and affect energy consumption. Service alarms are not visible to the user.

Water meter-related events

The device facilitates detecting the following events occurring at the metering point, which are related to wear or correct operation of the metering device (water meter):

- maximum flow;
- minimum flow;
- leaks;
- back flow;
- measurement unchanged.

Each event details are recorded. They start being recorded as soon as the time or volume thresholds are not yet exceeded, but the main criteria for event occurrence are met. For example, a leak-related event starts when the leak duration threshold is exceeded (and this will be the time stamp for the event start), but both the volume and time are recorded as soon as the flow is qualified to meet the leak conditions and the countdown to leak threshold exceeding is started. Therefore, there may be a difference between the recorded event details and the counter states or time elapsing from moments recorded as the event start and end. Event details correctly reflect the actual situation.

Event details are always updated at the end of an event. During the event, the details are not updated on an ongoing basis, but only at the algorithm control points, so they should not be interpreted as actual values at the time of their reading if the event is ongoing.

Maximum flow

The maximum flow is an event that occurs after detecting the volumetric flow rate above the maximum value still guaranteeing correct operation of the water meter for a time specified by the user.

Algorithm

The checking function is called out every 10 seconds. It checks whether:

- the number of revolutions of the indicator calculated in the period of 10 seconds is higher than the number of revolutions resulting from the value of the maximum flow threshold;
- duration of such a state is longer than the threshold value of the maximum flow duration.

If both conditions are met at the same time, then the event occurs.

The event is considered completed when the first condition ceases to be met.

Thresholds:

- Maximum flow threshold
- Maximum flow duration

Event details:

- First occurrence date and time
- Last occurrence start date and time
- Last occurrence end date and time
- Number of occurrences
- Duration
- Peak flow value

Minimum flow

The minimum flow is an event related to the detection of a volumetric flow rate sustained, for a certain period of time (specified by the user), below the value that guarantees correct consumption calculation without exceeding the permissible threshold errors.

Algorithm

The checking function is called out during detection of a water meter indicator revolution. It checks whether:

- the pointer revolution time is greater than the time resulting from the minimum flow threshold value, and whether it is shorter than the time resulting from the start-up threshold value;
- flow duration is greater than the minimum flow duration threshold value;
- there are back pulses.

An event occurs if: all three conditions are met at the same time.

The event is completed if:

- the flow value increases above the minimum flow threshold value (the indicator revolution time decreases below the time resulting from the minimum flow threshold);
- the flow value decreases below the start-up threshold value (time between pulses increases above the time resulting from the start-up threshold);
- the indicator rotates backwards.

An event is considered as completed if at least one of the above conditions is met.

Thresholds:

- Minimum flow threshold
- Maximum flow duration
- Start-up threshold (note: this threshold also used for leak-related events)

Event details:

- First occurrence date and time
- Last occurrence start date and time
- Last occurrence end date and time
- Number of occurrences
- Duration
- Volume

Leak

A leak is an event detected if the water flow is continuous for a user-defined time.

Algorithm

The function is called out when the indicator forward revolution is detected. It checks whether:

- the indicator revolution time is shorter than the time resulting from the start-up threshold (the flow is above the start-up threshold of the water meter);
- duration of such a state is longer than the leak duration threshold value.

If both conditions are met at the same time, then the event occurs.

The event is considered as completed when the indicator revolution time becomes longer than the time resulting from the start-up threshold.

Thresholds:

- Start-up threshold (note: this threshold also used for minimum flow events)
- Leak duration

Event details:

- First occurrence date and time
- Last occurrence start date and time
- Last occurrence end date and time
- Number of occurrences
- Duration
- Volume

Back flow

Back flow is an event generated by a specific water volume flowing back through the metering device.

Algorithm

The event algorithm uses two meters, i.e. the temporary and battery-operated meter. Each full indicator revolution in the backward direction increases the value of the temporary counter by 1, while each full indicator revolution in the forward direction reduces this value by 1 (down to 0). With each change, the temporary counter value is compared with the value of the back flow recording threshold.

If the temporary counter value is greater than the back flow recording threshold value, it is added to the battery counter value, and the temporary counter value is reset.

If the battery value exceeds the value specified by the back flow volume threshold, then the event is generated.

The event is considered completed when forward flow occurs.

Thresholds:

- Back flow recording threshold
- Reverse volume threshold

Event details:

- First occurrence date and time
- Last occurrence start date and time
- Last occurrence end date and time
- Number of occurrences
- Volume

Measurement unchanged

Unchanged measurement is an event occurring as a result of a complete lack of flow.

Algorithm

The checking function is called out every 24 hours. It checks whether the conditions specified by the event thresholds are met:

- the number of indicator revolutions, calculated during the day, is smaller than the value resulting from the maximum permissible volume threshold during the day;
- the number of indicator revolutions calculated during a preset number of days (defined by the threshold of the number of downtime days) is lower than the value resulting from the maximum allowed volume threshold during the preset number of downtime days;
- the number of downtime days is equal to or greater than the number of days determined by the threshold of the number of downtime days.

The event occurs if all three conditions are met at the same time.

Thresholds:

- Maximum permissible volume during a day
- Maximum permissible volume during the preset number of downtime days
- Number of downtime days

Event details:

- First occurrence date and time
- Last occurrence start date and time
- Last occurrence end date and time
- Number of occurrences
- Duration

7.9.5. Water meter monitoring

The monitoring mode is a device operation mode collecting flow samples much more often than the archive reading mechanism allows. After starting the mode, sampling lasts 7 days and the collected data can be read out in daily cycles or once after the mode is finished.

Monitoring mode activation requires taking the following steps:

- mode parametrisation;
- mode activation.

Depending on the parametrisation, when the mode is active, the device can send notifications to the telemetry server (make transmissions) after each 24 hours of the sampling process or once, at the end of the entire weekly session.

7.9.6. Emergency text message

In order for the module to send an emergency text message to a selected phone number, this number must be given with the country code, e.g.: +48..... The device sends text messages in the following situations:

- no GPRS communication with the telemetry server (emergency text message);
- occurrence of an event for which a text message is configured.

Format of an emergency text message sent in the case of GPRS communication breakdown:

MOD. NO.: 0	Transmission module number
METER NO.: 00000000	Water meter number
CUR: 2020-10-28T18:04:43+01:00	Current measurement, date
P:0;T:0	P - forward revolution counter, T - backward revolution counter
LOG: 2020-10-28T18:04:43+01:00	Logged measurement, date
P:0;T:0	P - forward revolution counter, T - backward revolution counter

Format of an event-related text message sent at the start of an event or alarm:

MOD. NO.: 0

METER NO.: 00000000

2020-10-30T00:00:00+01:00

NO FLOW

Event details are not transmitted, as a text message is always sent when the event starts, and the details correspond to the moment in which the set thresholds are exceeded.

7.10. Removal

7.10.1. Removal of the IN-GSM inductive transmission module from a water meter

Note! Before removing the module, transmission must be forced to save the current data from the module.

Procedure for removing an IP65 version device from a water meter:

- Press the intermediate ring with one hand.
- With the other hand, tilt the module outwards in relation to the centre of the water meter so that the module comes out from the intermediate ring latches.

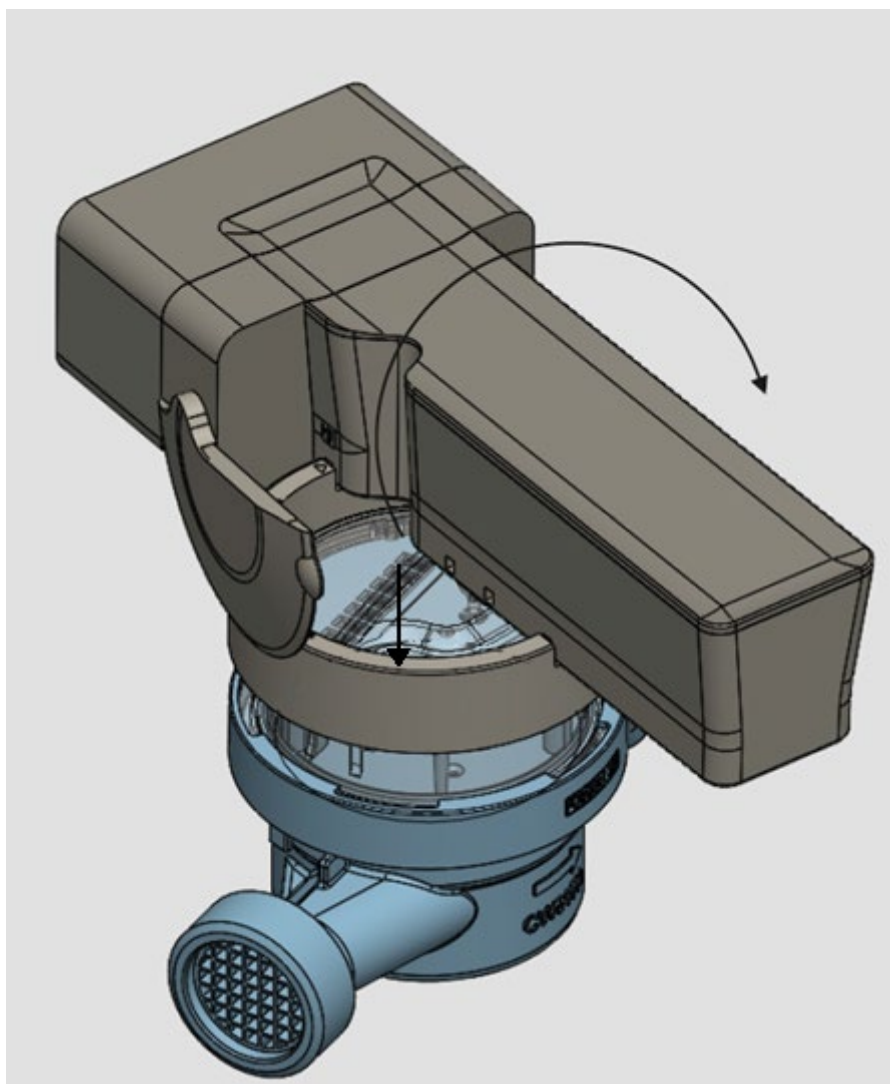

Fig. 38. Removing an IN-GSM transmission module from an IP65 water meter

- Prise the intermediate ring from the top with a small flat screwdriver right next to the latch. Do not prise it directly at the latch location!. This may result in its damage causing the module to fall from the water meter.

Note! When reinstalling the same or new module, use a new intermediate and locking ring.

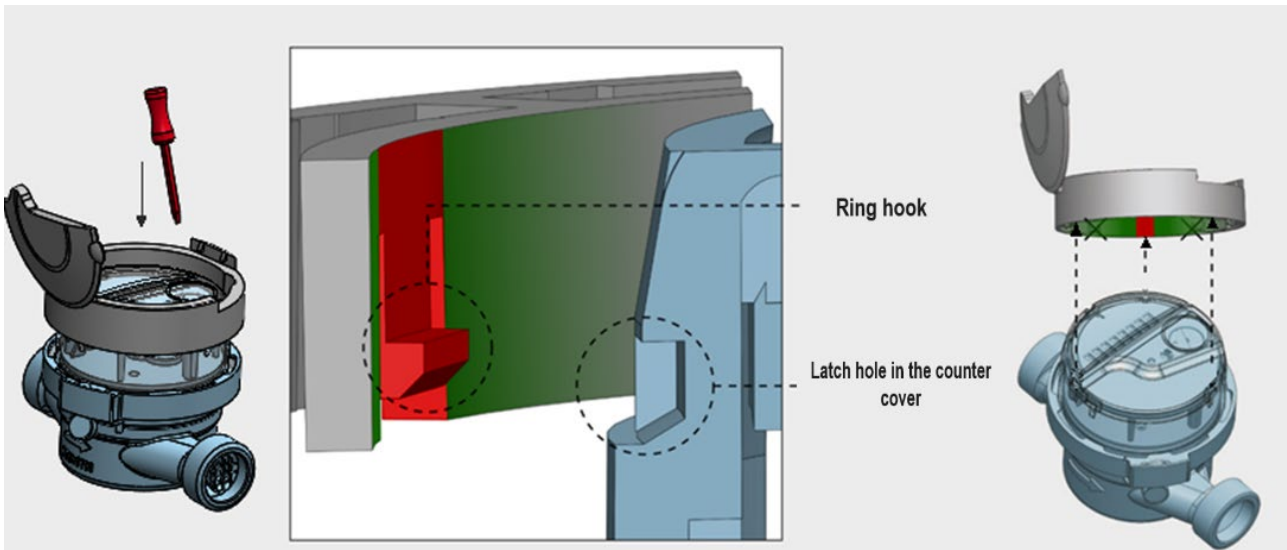

Fig. 39. The red field indicates the location in which prising the latches may result in their damage

Procedure for removing an IP68 version device from a water meter:

- Holding the water meter with one hand, pull out the ring lock (Fig. 40) from the counter guard latch and IN-GSM module socket.

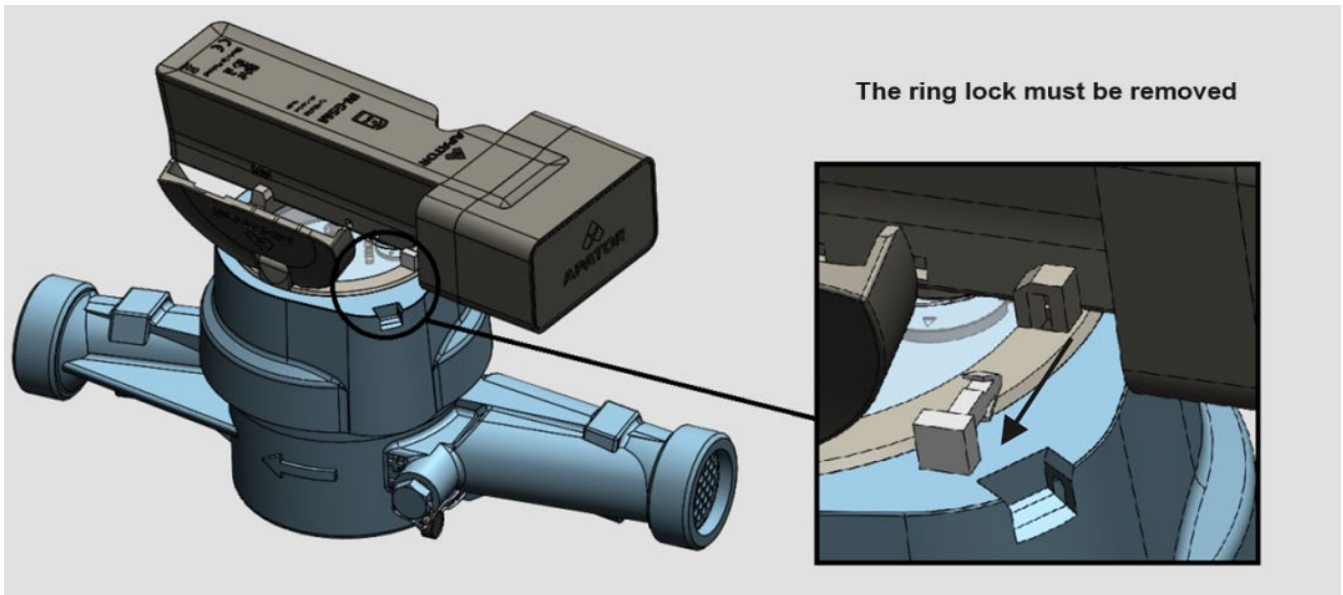

Fig. 40. Removing a ring lock from a IP68 water meter

- While still holding the water meter with one hand, tilt the transmission module outward with the other hand in relation to the centre of the water meter, so that the module comes out from the water meter counter enclosure intermediate ring latches.

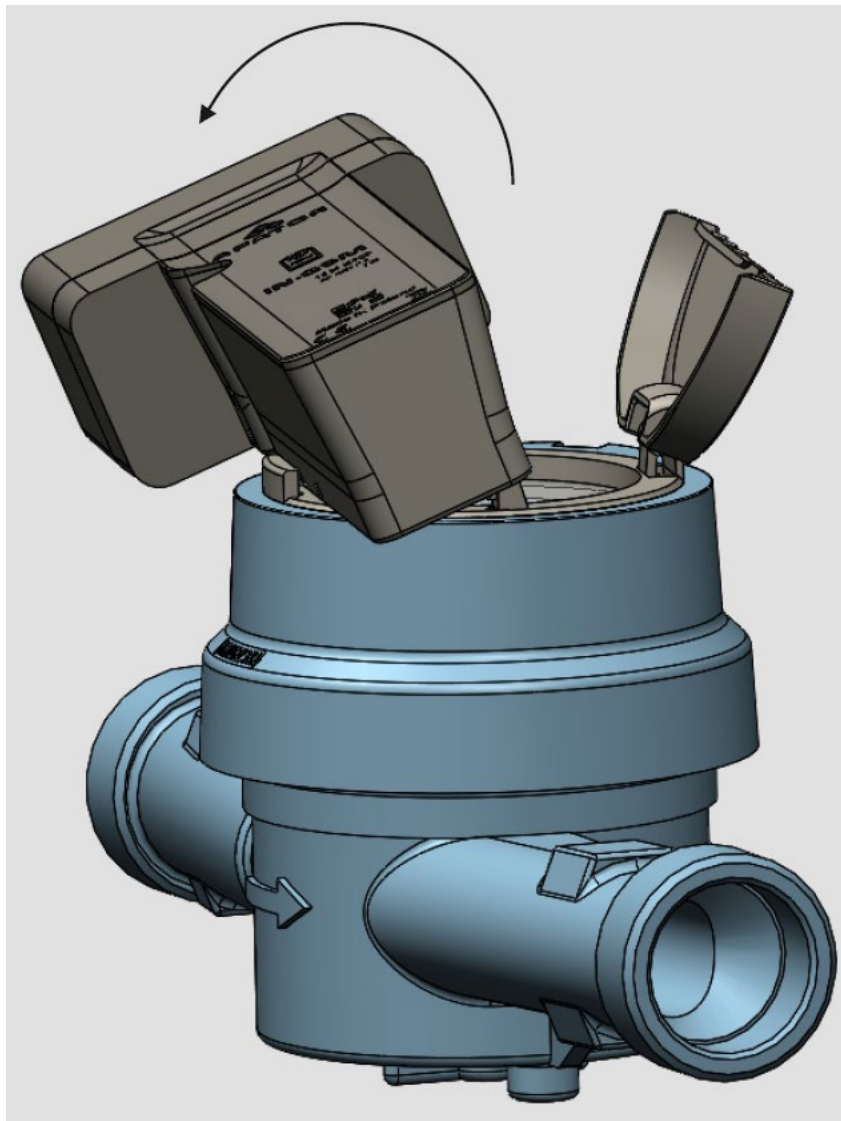

Fig. 41. Removing an IN-GSM module from an IP68 water meter

7.9.1 Battery replacement

When replacing the battery in the device, make sure that the data is consistent.

Battery disassembly

After reading out the registers, remove the spent battery according to the following procedure:

1. Disconnect the battery module from the transmission module by turning the battery module to the left to break the seal installed in the battery module.
2. Align the markers on the device enclosure and battery. The battery module can be safely removed in this position.
3. Disconnect the DF3-2EP-2C power supply connector.

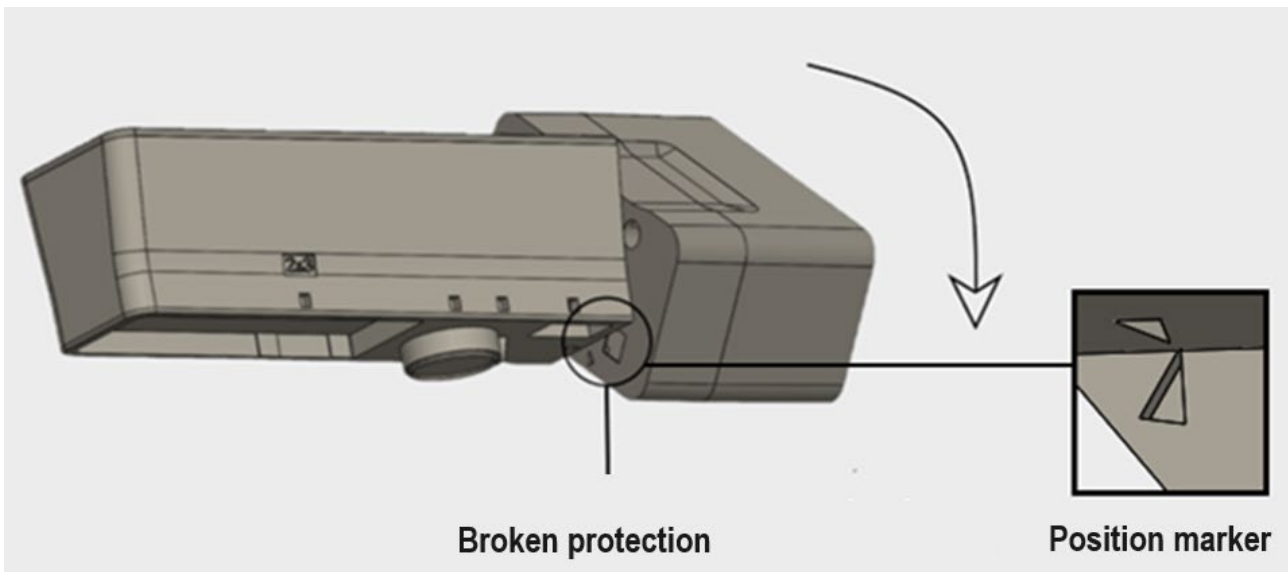

Fig. 42. Battery disassembly

Note! Do not throw away the spent battery! A spent battery must be disposed of as required!

Proceed in a reversed order in relation to the batter disassembly procedure:

Battery installation

1. Connect the power supply connector to a new battery.
2. Place the battery module onto the device, ensuring that the markers are in the correct position, as shown in the figure below.

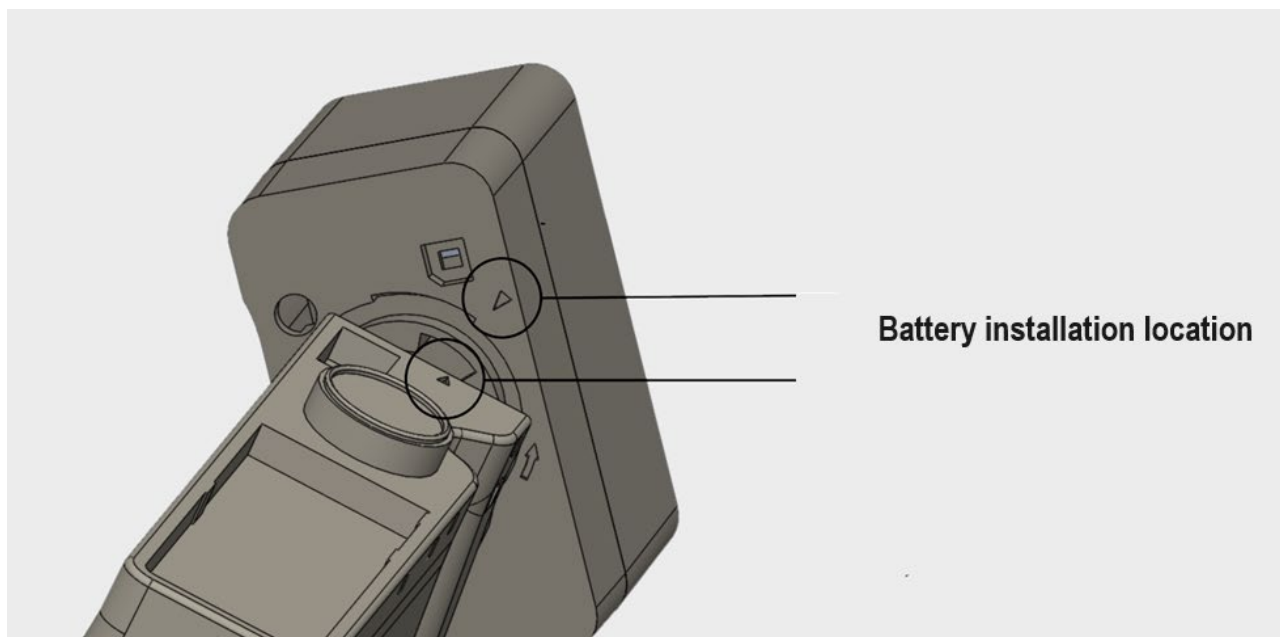

Fig. 43. Module assembly system

3. Place the battery module at the transmission module in line with the markers, press it home and turn clockwise in the direction indicated by the arrow on the battery enclosure.

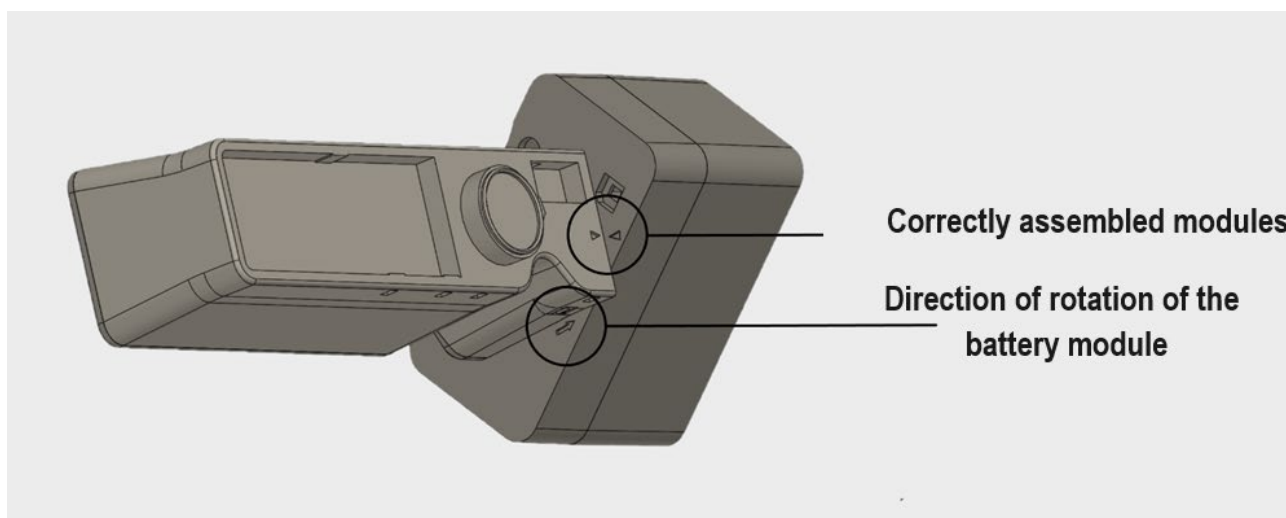

Fig. 44. Correctly positioned modules

After connecting the battery module correctly, press the seal into the mounting hole.

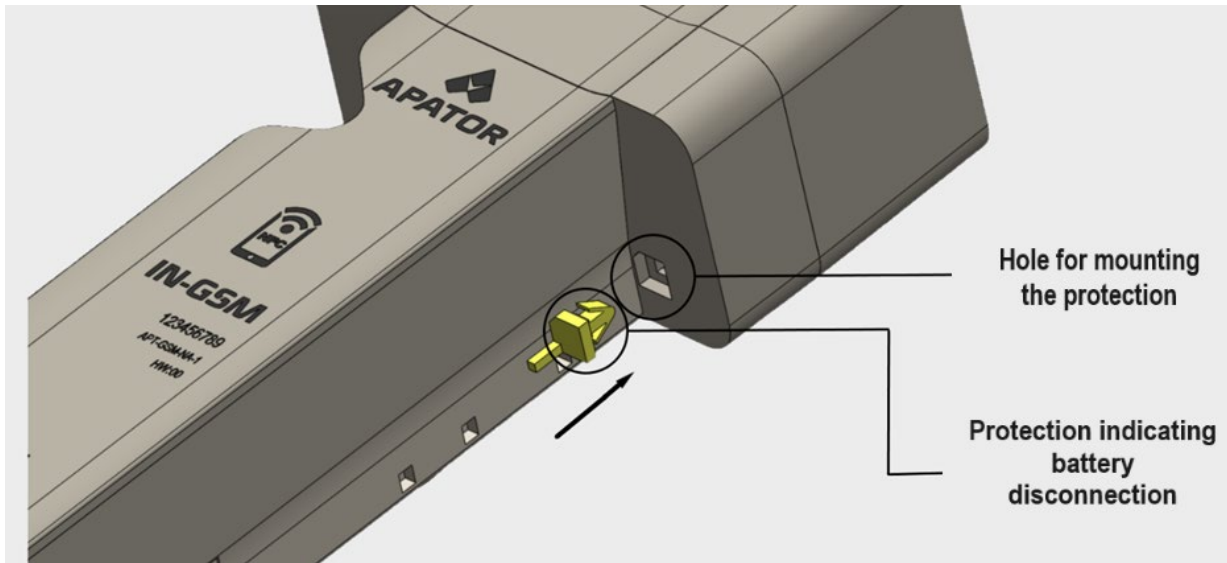

Fig. 45. Seal installation

A correctly assembled device should look as shown in the figure below:

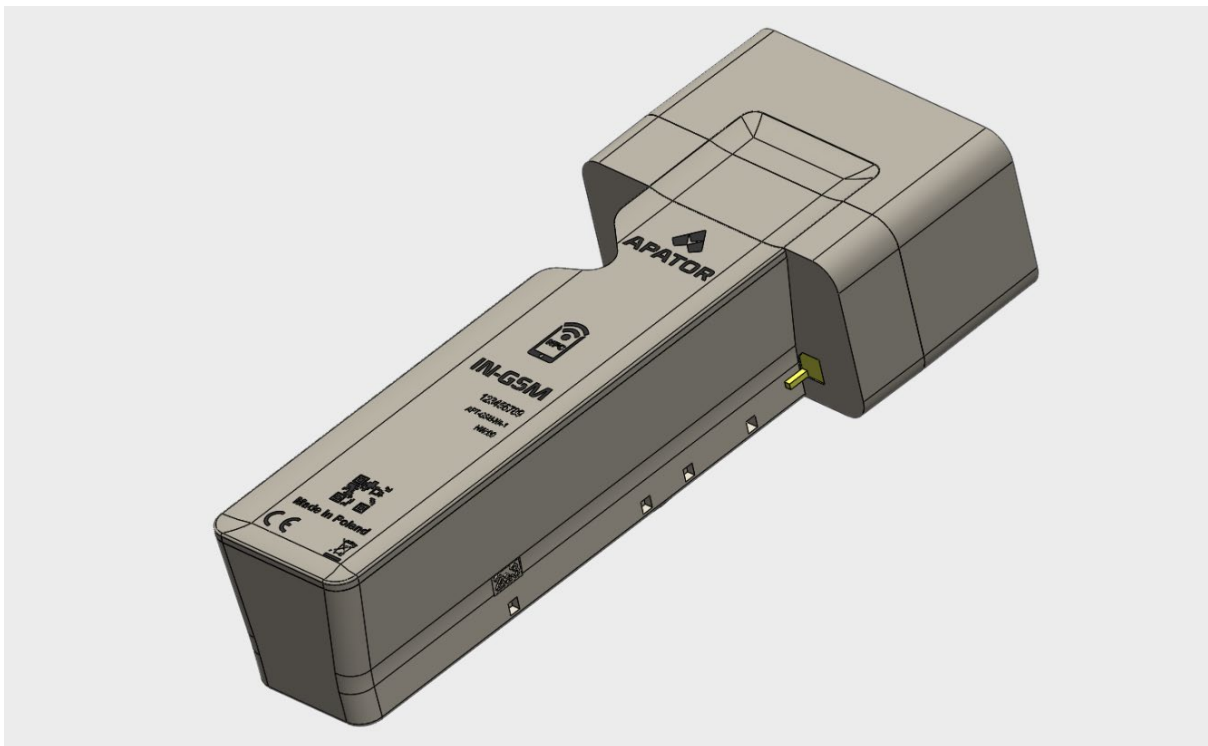

Fig. 46. Correctly assembled transmission module after battery replacement

Note! When installing a battery, press the battery module firmly against the transmission module so as to squeeze the gasket, otherwise the correct installation of the battery module will not be ensured, and the IP68 degree of protection for the entire device will not be guaranteed.

7.10 Diagnostics and maintenance

7.10.1. Coil test mode

To test the coils:

- Start the water meter flow, so that the indicator revolution speed does not exceed 0.5 rpm.
- Install the module on the water meter.
- Start the coil test.

NOTE! The test duration must be long enough for the indicator to rotate at least 3 times.

7.10.2. GSM connection test

To perform a GSM connection test for the communication module, a transmission must be forced.

7.10.3. Reprogramming

Note! During software installation, the water meter revolutions are not counted. This applies to the installation itself; while downloading the file, all device functionalities are operational. The installation process starts when the download is complete and it lasts up to 10 seconds.







7.11 Water meter replacement

If a water meter is removed together with the module, a transmission must also be forced to record current data obtained from the module.

The water meter must be replaced in accordance with the relevant operating manual.

Install the device removed from the previous water meter on a newly installed meter and configure it. If a new transmission module is installed, configuration with the installed water meter is required.

8. Operating precautions

	<p>The product must be protected against impact and shock during transport and kept at temperatures between -20°C and +70°C (the maximum temperature is allowed for less than 3 days).</p>
	<p>Store the product at temperatures between +5°C and 35°C.</p>
	<p>Having installed the product on a water meter, exit the storage mode and set the configuration as explained in this manual.</p>
	<p>Operate the product in line with the parameters provided in section 3 (Technical data), at ambient temperatures, and ensuring that the conditions specified in this manual are met.</p>
	<p>The device contains a lithium battery - it must not be charged, short-circuited, crushed, disassembled, heated above 100° or burnt.</p>
	<p>Data security is ensured by using the AES128 encrypted communication protocol with the package authentication function. Two AES keys are used, one for utility communication purposes (user key), and the other to perform operations available only for the service personnel (service key).</p>

9. Warranty terms and conditions

Aparator Powogaz guarantees proper performance of the product for the duration specified in § 2 of the Aparator-Powogaz General Warranty Terms & Conditions, only if the requirements specified for transport, storage and operation are followed.

10. Environmental protection

Do not dispose of with regular waste. Return the product to a WEEE collection point for disposal. Help protect the natural environment.



Revision history

date	version	author	description
01.03.2022	1.0	Janusz Geisel	Second edition
30.10.2023	1.0	Tomasz Szulc	Third edition



Apator Powogaz S.A.

Jaryszki 1c, 62-023 Żerniki

Secretary's Office: sekretariat.powogaz@apator.com, phone: +48 61 84 18 101

Sales / Customer Service: phone: +48 61 84 18 149

Customer Service Support: handel.powogaz@apator.com

Export Department: export.powogaz@apator.com

Technical Support: support.powogaz@apator.com, phone: +48 61 8418 131, 134, 294

Complaints: reklamacje.powogaz@apator.com

www.apator.com

2024.026.I.EN