

Ultrimis PRO

Ultrasonic water meter DN80-DN100

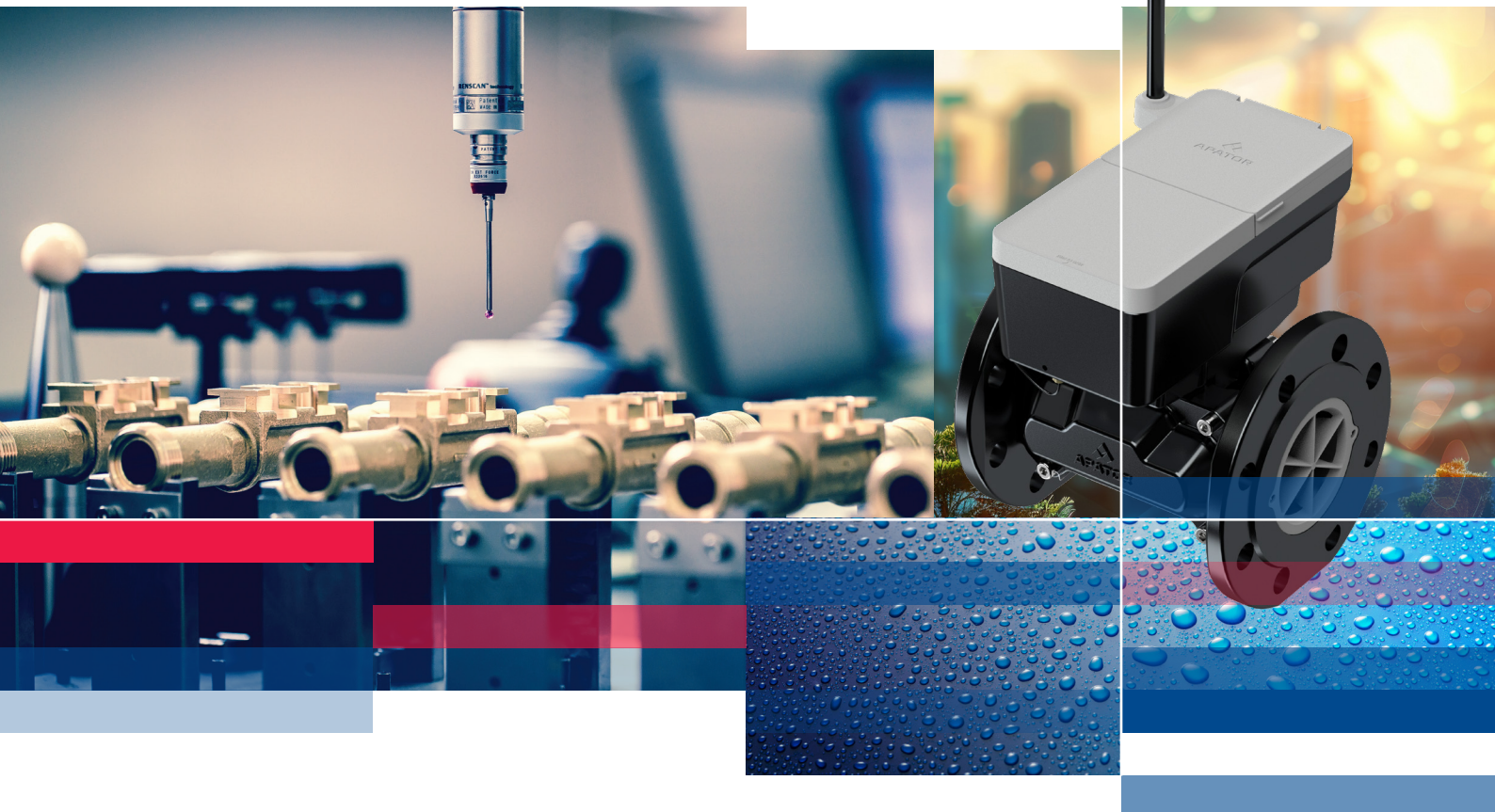

Ultrimis PRO, a state-of-the-art ultrasonic water meter with the latest patented design features the W-Sonic Technology, a unique metering method. The W-Sonic Technology enables meter readings in the R1000 range with the starting flow already from 20 l/h.

The water meter is designed and manufactured to the highest quality standards. The water meter is rated at IP68 and with a high resistance to hydraulic shock and magnetic interference. The measurement chamber is designed to provide the water meter with insensitivity to hydraulic shock. The ultrasonic measurement technology of the water meter is completely impervious to interference from magnetic fields.

APPLICATION

Water supply systems with the maximum cold water temperature of 50°C, requiring reliable water consumption metering and reliable data communication methods, including remote meter reading over NFC, WM-Bus or LoRaWAN. The water meter can be installed in any orientation and does not require upstream and downstream sections of straight piping.

Ultrimis PRO



Advantages

Provides savings

- Water meter symmetry – **means the same measurement coefficient** in both flow directions, ensuring full control and maximum efficiency
- High-precision measurement improves **efficiency** of water use: the water meter can detect all leaks in the supply system
- Pass-through design of the measurement chamber, **without moving parts**, resistant to contamination - no expenses for inspections and maintenance
- No upstream or downstream **straight sections** of piping required
- Robust design, reliable electronic components and **minimum electrical power demand** for a stable, long-term operation
- A wide **measurement range** with immunity to electrical conductivity of metered water (as required for electromagnetic water meter systems)
- Extremely **low pressure loss** (and low resistance to flow)

Convenient in operation

- Standard **IP68**-rated hermetically sealed body
- **No risk of physical wear** of the measurement chamber components during continuous operation, even at high flow rates
- MAP – **16 bar**
- Body material – **cast iron**
- The water meter head, which can be installed in two orientations, ensures **maximum reading convenience** – regardless of how the water meter is installed
- Resistant to **strong magnetic fields**
- Resistant to **hydraulic shock**
- Highly resistant to overload flow rate – **Q₄**
- The antenna mounted on a magnet facilitates installation and **enhances its capabilities**
- The antenna with a 3-meter cable **facilitates achieving proper water meter range** in hard-to-reach locations

Measurement accuracy

- Measuring range up to **R1000** in every operating position (**H, V**)
- Starting flow already from **20 l/h**
- **Stable** measurement system performance by insensitivity to fouling
- **Back flow** with an accuracy up to R1000

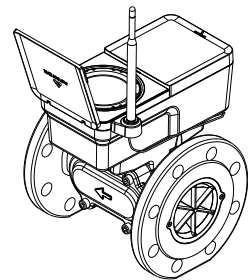
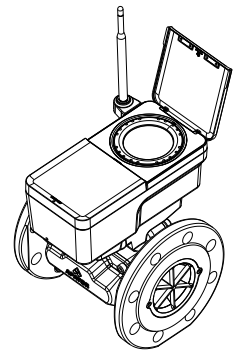

Environmentally friendly

- Extremely **low power usage** when in operation
- Very low lithium content: **Li < 3.6 g**
- Expected battery life up to **16 years** (depending on configuration and environmental conditions)
- Low energy output at the water supply side (the unit pressure drop across the water meter is below **0.08 bar** for Q_3)
- **Very low weight**: low transport costs
- Low carbon footprint

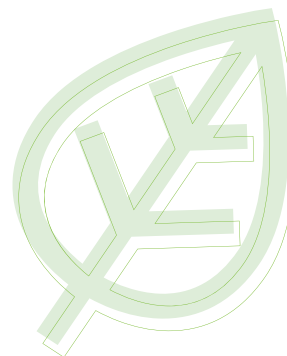

Innovation

The Ultrimis PRO water meter features a unique measurement system: it emits an ultrasonic beam across the measurement chamber, which results in steady indications and errors in the whole measurement range. This is the W-Sonic Technology which includes distinctive characteristics:

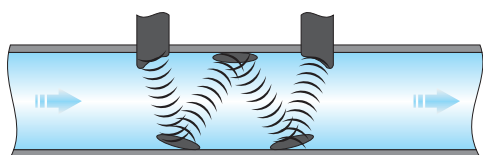

- With its unique ultrasonic beam pattern, the Ultrimis PRO can be much more compact than other ultrasonic metering systems
- The full-bore design does not entrap any fouling or solids
- Insensitive to measurement bias from water contamination
- Sophisticated control algorithms of the ultrasonic beam system provide compensation for component ageing
- Requires no filters or check valves

Communication

- Water meter data reading over NFC (Near Field Communication)
- RF (radio-frequency) reading of indications compatible with WM-Bus and/or LoRaWAN
- RF indication reading for walk-by and drive-by reading systems and stationary reading systems
- Secondary verification at any suitable location with the Testbox module and a dedicated application

NFC configuration

The Ultrimis PRO water meters feature standard NFC data communication which enables configuration of the operating mode, reading of actual parameter values of the instrument and downloading the historical indications of statuses and errors (even at a low battery voltage or meter failure).

Developed specifically for the Ultrimis PRO water meter, the data communication interface includes a dedicated SPIDAP Mobile application and the Testbox module. The data communication interface enables re-verification by secondary verification operators.

The data logger supported by NFC enables modification of the interval and range of data logging.

The data logging interval can be configured from 12 minutes to 45 days. One of the 10 predefined data acquisition sets can also be selected.

Depending on the data acquisition set selected, up to 800 unique records can be stored. The data acquired can drive histograms to evaluate whether the water meter has been specified correctly for its actual application.



RF reading

The water meter has an integrated RF data communication module for easy and efficient remote data reading in walk-by, drive-by and stationary reading systems.

Wireless M-Bus + LoRaWAN

The Ultrimis PRO LoRaWAN + WM-Bus water meter versions are intended for stationary reading systems. They facilitate default data communication over LoRaWAN with a long range and a low power consumption. If there is no LoRaWAN service, the water meter automatically switches over to WM-Bus communication.

One of the following data communication methods can also be configured for permanent use:

- LoRaWAN only
- WM-Bus only
- Mixed, LoRaWAN is default; if there is no LoRaWAN service, WM-Bus is automatically switched to.

LoRaWAN communication is divided into two areas:

- Standard data communication, each with an RF data frame output every 7 hours and holding the data from the previous 14 hours
- Emergency data communication is triggered instantly when a predefined event emerges.

WM-Bus/LoRaWAN/NFC communication allows you to receive the following data:

- Water meter indications (historical and at the time of reading)
- Reverse volume (at the time of reading)
- Water temperature (at the time of reading)
- Events/alarms (for the last logged month, current month, and at the time of reading) such as:
 - Reverse flow
 - Low flow
 - High flow
 - No water
 - Low battery
 - Tampering detected
 - Temperature limit violation
 - Zero flow

LoRaWAN network extension

Enhance your IoT network with our advanced **LoRaWAN® APRANGE**. Extend the reach of your Ultrimis PRO water meters for improved connectivity, even in challenging environments. Explore the potential of IoT solutions with our dependable LoRaWAN® APRANGE.

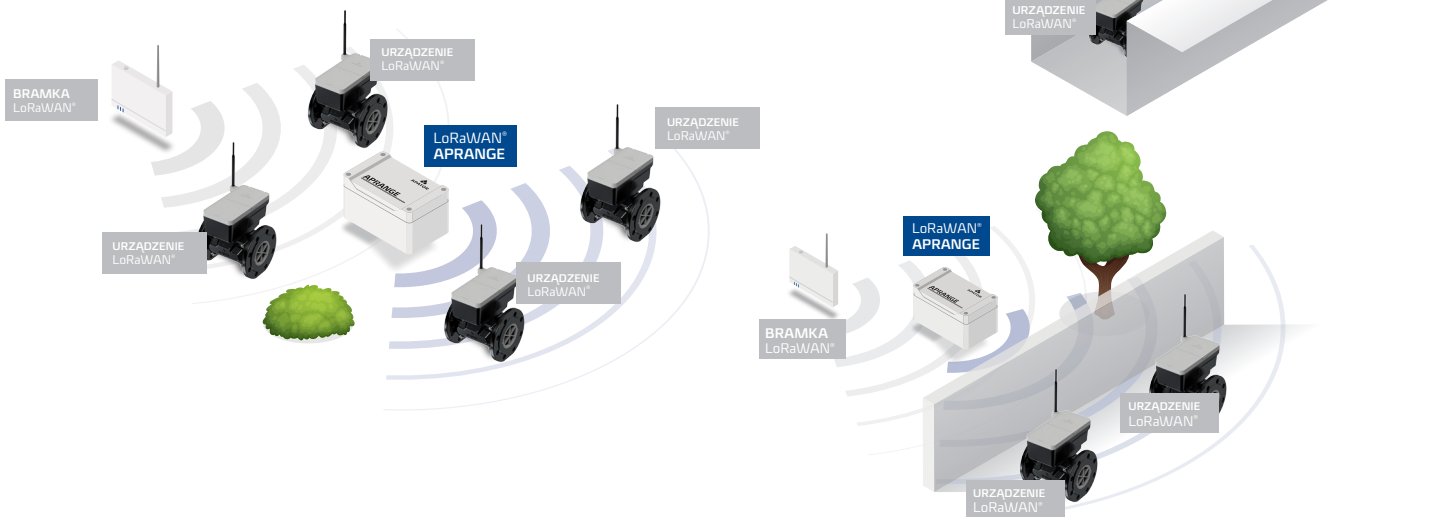

LCD display functions

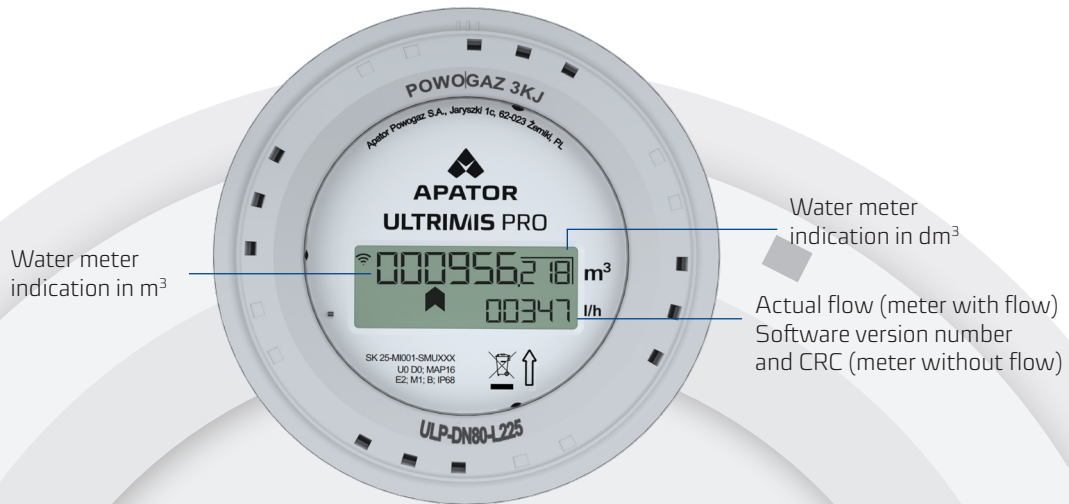

Shipping mode
Shipping mode disabled when the minimum volume detected is: equivalent to volume Q_2 , according to the device's R class, over a period of 1 hour or disabled on command via NFC

Water meter leak
Alarm trigger:
flow $> 0,3 \times Q_2$ for 720 min

Metering online

Test mode

RF transmission on

No water
Alarm triggered after 30 s

Information mode

Low battery

Debug mode

Tampering detected

Water main leak (bypass flow)
Alarm trigger: flow $> Q_4$ for 30 s

Water flow direction indicator
The forward arrow is displayed

Back flow
Alarm triggered after > 30 s back flow time
Back arrow is displayed

Zero flow
Alarm triggered after > 8 s of zero flow
Arrows don't appear

Events not indicated on the LCD

Overtemperature
Switchover thresholds:
for T50: $< 2^\circ\text{C}$ or $> 50^\circ\text{C}$

Table 1. Technical data

Specification			Ultrimis PRO			
			ULP80		ULP100	
Nominal diameter	DN	mm	80		100	
Permanent flow rate	Q ₃	m ³ /h	40	63	63	100
Overload flow rate	Q ₄	m ³ /h	50	78.75	78.75	125
Measurement range	R	Q ₃ /Q ₁	1000			
Transitional flow rate	Q ₂	dm ³ /h	64	100.8	100.8	160
Minimum flow rate	Q ₁	dm ³ /h	40	63	63	100
Measurement range	R	Q ₃ /Q ₁	800			
Transitional flow rate	Q ₂	dm ³ /h	80	126	126	200
Minimum flow rate	Q ₁	dm ³ /h	50	78.8	78.8	125
Measurement range	R	Q ₃ /Q ₁	400			
Transitional flow rate	Q ₂	dm ³ /h	160	252	252	400
Minimum flow rate	Q ₁	dm ³ /h	100	157.5	157.5	250
Starting flow for R400, R800, R1000	–	dm ³ /h	20			
Range for R400, R800, R1000	–	Q ₂ /Q ₁	1.6			
Temperature class (EN and OIML)	–	°C	T30, T50			
Flow profile sensitivity class (EN)	–	–	U0, D0			
Counter indication range	–	m ³	999 999			
Scale interval value	–	m ³	0,001			
Maximum permissible error in the range of Q ₂ ≤ Q ≤ Q ₄	ε	%	±2 for cold water T ≤ 30°C ±3 for water T > 30°C			
Maximum permissible error in the range of Q ₁ ≤ Q < Q ₂	ε	%	±5			
Battery	–	–	Lithium battery, D type, 3.0 V DC			
RF	–	–	868 MHz up to 25 mW E.R.P. EU868 MHz LoRa up to 25 mW E.R.P.			
RF communication standard	–	–	OMS-compliant WM-Bus OMS-compliant WM-Bus + LoRaWAN			
Radio transmission mode (WM-Bus)	–	–	T1 or C1			
Water pressure class	EN	–	MAP10, MAP16			
	OIML	–	0.3 to 16			
Pressure loss class at Q ₃	EN	ΔP	ΔP10 for T30, T50			
	OIML	–	0.1			
	manufacturer-specified	–	0.015	0.071	0.015	0.054
Installation orientation	–	–	H, V			
Reverse flow (manufacturer-specified)	–	–	Water meter designed for measuring reverse flow			
Relative humidity	–	%	≤ 100			
IP rating			IP68			
Water meter body material			Cast iron			
Connection end			Flange			
Dimensions	L	mm	225		250	
	h	mm	95		105	
	H	mm	261.95		271.95	
	H1	mm	267		277	
	H2	mm	371.35		381.35	
	H3*	mm	442.85		452.85	
	Dz	mm	200		220	
	G	mm	195		215	
	b	mm	123.75		123.75	
B	mm	247.50		247.50		
Weight	–	kg	14.20		15.55	

* Height with antenna attached, can be removed

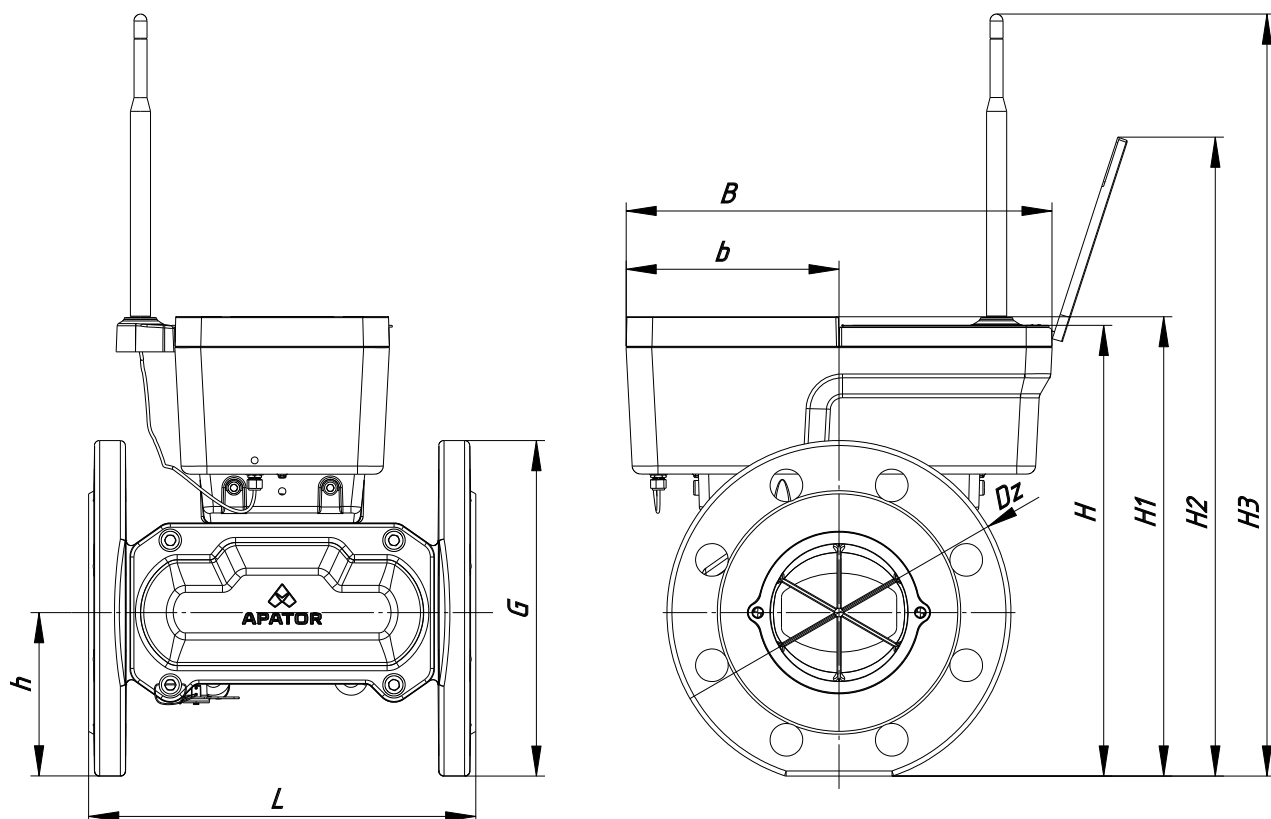

Pressure loss chart

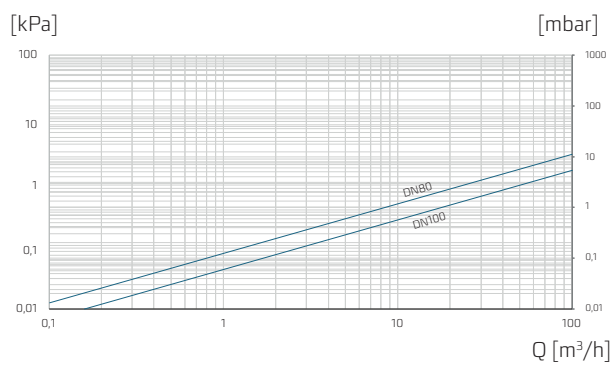

Connection fittings

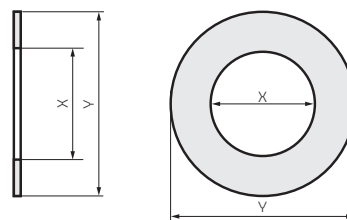

DN	X [mm]	Y [mm]
80	89	142
100	115	162

Typical error chart

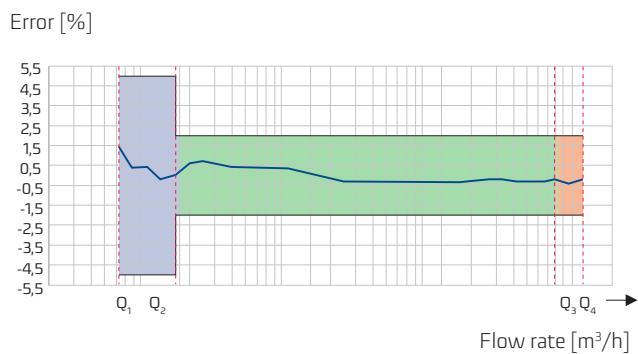

Installation, configuration and remote reading

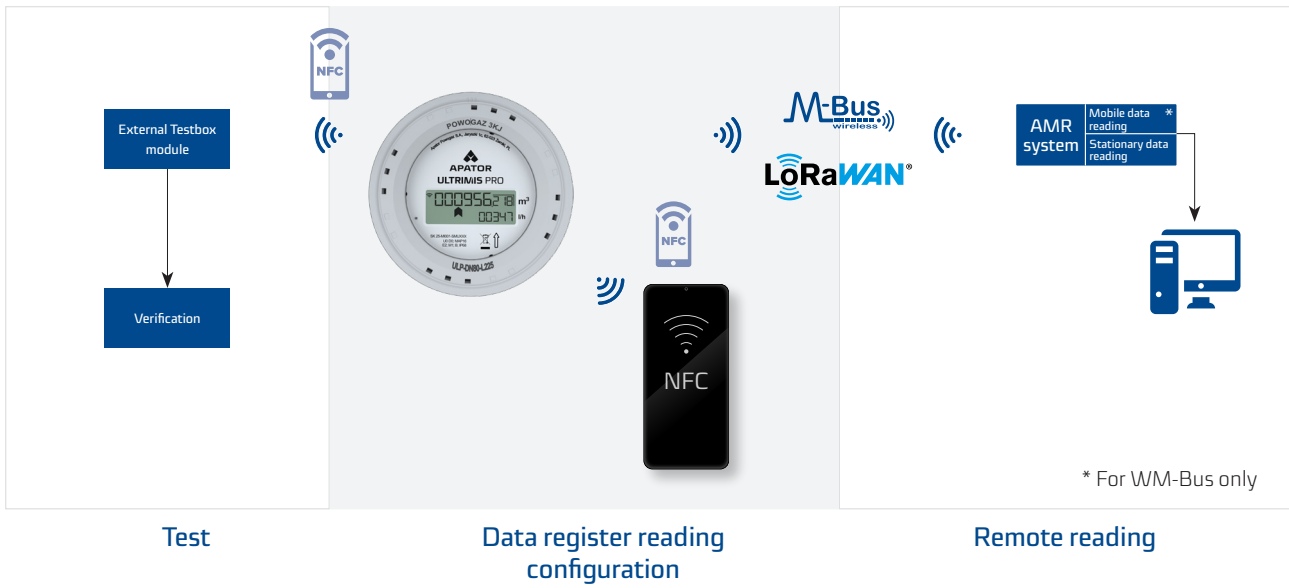

Available options:

- Testbox
- Konwerter Bluetooth/radio, USB

The data presented in the data sheet was correct on the date of publication.
The manufacturer reserves the right to modify and improve its products without notice.
This publication is intended for information purposes only and shall not be construed as a commercial offer under the Polish Civil Code.



Apator Powogaz S.A.

Jaryszki 1c, 62-023 Żerniki, Poland

Office: sekretariat.powogaz@apator.com, tel. +48 61 84 18 101

Sales / Customer Service: tel.: +48 61 84 18 149

Customer Service Centre Support: handel.powogaz@apator.com

Export: export.powogaz@apator.com

Technical Support: support.powogaz@apator.com, tel. +48 61 8418 131, 134, 294

Warranty Claims: reklamacje.powogaz@apator.com