



COMPASS switch disconnectors

2026 product catalogue

mSD / mSDF

Switch disconnecter / fuse switch disconnecter

The **mSD** and **mSDF** disconnectors are part of the **COMPASS range**. The **mSDF** disconnectors are intended for NH fuse links ranging in size from 000 to 1 and with a rated current (I_n) of up to 250 A. The **mSD** disconnectors are intended for rated currents (I_n) of up to 315 A.

The **COMPASS** range of fuse switch disconnectors offers a new standard of safety and ergonomics. The word **COMPASS** combines the words **COMPact** and **ASSEMBly**, which capture the key features our disconnectors.

The **mSDF** disconnector from the **COMPASS** range has been designed in compliance with the following applicable standards:
PN-EN IEC 60947-1:2021-07,
PN-EN IEC 60947-3:2021-07.



mSD 80-P3
with H3 handle and additional C2 covers

DESIGN

The mSD switch disconnecter and the mSDF fuse switch disconnecter from the COMPASS range are available in two standard versions: three-pole (P3) and four-pole (P4).

The COMPASS switch disconnectors have a modular design, allowing for the assembly of versions comprising three or four identical functional blocks – modules – attached to the drive unit. The compact design of the mSD and mSDF disconnectors means they are small enough to be used in withdrawable switchgear, among other applications.

All plastic components used in this range of disconnectors are made from halogen-free, self-extinguishing, glass-fibre-reinforced materials. The flame retardants we use make our plastics compliant with the highest flammability

rating – V0. In practice, this means that the disconnecter will self-extinguish after the ignition source has been removed, and that no burning pieces of plastic will break away or fall off. The silver-plated contacts ensure low power dissipation.

The COMPASS switch disconnecter has an operating shaft which can be installed from the front side of the disconnecter and from the drive side. The modular design of the disconnectors, available in special versions, also allows the drive to be positioned between the current-carrying sections. This approach is used to save space in the switchgear by reducing the width of the cubicle while accommodating disconnectors of various sizes, and at the same time maintaining an aesthetic appearance by aligning all drives along a single axis.

The special design of the handle reliably indicates the current position of the disconnecter, which can be in one of two or three positions (ON, OFF and TEST). It also allows for the installation of three Ø 6 padlocks, which are set to the OFF position by default.

The mSDF fuse switch disconnecter allows wiring from the current-carrying contacts for applications such as voltage signalling and fuse link failure monitoring.

The disconnecters provide an IP20 protection rating. These disconnecters allow for the installation of two sizes of terminal covers – short or long – depending on the customer's requirements.

The mSDF fuse switch disconnecter is intended for gG fuse links. These disconnecters are designed for plate mounting using special brackets; additionally, the mSDF 80 is designed for mounting on a TH35 busbar.

FUNCTIONALITY

- maximum safety and easy installation
- locking cover to prevent removal of fuse links in the "ON" position
- self-extinguishing V0 insulating material
- operating shaft front side and drive side
- direct connection of three miniature switches possible (additional ones can be installed one above the other)
- door locking in operation mode – intentional release possible with a tool
- dynamic self-cleaning contacts
- high mechanical and electrical endurance
- high short-circuit and switching capacity
- double safe isolation gap in each current circuit of the disconnecter
- complete isolation of the fuse links in the "OFF" position
- wide range of accessories

APPLICATIONS

The **COMPASS** disconnectors are intended for electricity distribution, connecting and protecting electrical devices against short circuits and overloads in three-phase and direct current networks.

The **mSDF 80** disconnectors can be used as:

- disconnectors for controlling and protecting electric motors and other AC devices
- disconnectors for outgoing power in distribution devices

OPERATING CONDITIONS

- installation in rooms free from dust and corrosive or explosive gases
- altitudes up to 2000 metres above sea level
- ambient temperature from -25°C to +55°C

Tabela 1. Technical data

Parameter		mSDF 80 disconnector				mSDF 160 disconnector		mSDF 250 disconnector	
Rated thermal current $I_{th}=I_n$	A	80				160		250	
Rated voltage U_n	V	690	1000			690	690		
Utilisation category	-	AC-23A	DC-22A	AC-20A	DC-20A	AC-23B	DC-22B	AC-23B	DC-22B
Rated switching current I_e	A	80	80	-	-	160	160	250	250
Switching voltage	V	690	440	-	-	690	440	690	440
Rated short-circuit making current	kA	7	16	-	-	8	-	8	-
Rated impulse withstand voltage U_{imp}	kV	8				8		8	
Rated insulation voltage U_i	V	1000				1000		1000	
Rated frequency	Hz	50-60				50		50	
Mechanical endurance	operating cycles	10000				8000		8000	
Electrical endurance	switching cycles	1500				1000		1000	
Rated duty		Continuous duty				Continuous duty		Continuous duty	
Degree of protection		IP20				IP20		IP20	
Fuse link size		000				00		1	







Tabela 2. Technical data

Parameter		mSD 160 disconnecter		mSD 250 disconnecter		mSD 315 disconnecter	
Rated thermal current $I_{th}=I_n$	A	160		250		315	
Rated voltage U_n	V	690		690		690	
Utilisation category	-	AC-23B	DC-22B	AC-23B	DC-22B	AC-23B	DC-22B
Rated switching current I_e	A	160	160	250	250	315	315
Switching voltage	V	690	440	690	440	690	440
Rated short-circuit making current	kA	8	-	8	-	8	-
Rated impulse withstand voltage U_{imp}	kV	8		8		8	
Rated insulation voltage U_i	V	1000		1000		1000	
Rated frequency	Hz	50		50		50	
Mechanical endurance	operating cycles	10000		8000		8000	
Electrical endurance	switching cycles	1000		1000		1000	
Rated duty		Continuous duty		Continuous duty		Continuous duty	
Degree of protection		IP20		IP20		IP20	

Tabela 3. Standard versions

Version		Weight [kg]	Article No.
mSDF 80-P3	3-pole fuse switch disconnecter for plate mounting	1 kg	63-002264-001
mSDF 80-P3-E	3-pole fuse switch disconnecter for TH 35 busbar mounting	1 kg	63-002264-002
mSDF 80-P4	4-pole fuse switch disconnecter for plate mounting	1.3 kg	63-002264-003
mSDF 80-P4-E	4-pole fuse switch disconnecter for TH 35 busbar mounting	1.3 kg	63-002264-004
mSDF 160-P3	3-pole fuse switch disconnecter for plate mounting	1.7 kg	63-436160-001
mSDF 250-P3	3-pole fuse switch disconnecter for plate mounting	3.03 kg	63-436250-505
mSD 160-P3	3-pole switch disconnecter for plate mounting	1.43 kg	63-436160-004
mSD 250-P3	3-pole switch disconnecter for plate mounting	1.43 kg	63-436250-650
mSD 315-P3	3-pole switch disconnecter for plate mounting	2.55 kg	63-436400-502

Tabela 4. Types of terminals

	mSDF 80	mSDF 160	mSDF 250	mSD 250	mSD 315
Frame	terminal	M8 screw terminal	M10 screw terminal	M8 screw terminal	M10 screw terminal
Terminal drawing					
Cable conductor cross-section	rm  2.5- 95 mm ² re  2.5 - 35 mm ²	cable lug max. 120 mm ²	cable lug max. 240 mm ²	cable lug max. 120 mm ²	cable lug max. 240 mm ²
Tightening torque	4 Nm	12 Nm	20 Nm	12 Nm	20 Nm

*) The disconnecter does not include screw terminals – there are holes for terminals



mSDF 160-P3
with additional C4 covers



mSD 250-P3
with additional C4 covers



mSDF 80-P3



mSD 315-P3
with additional C5 covers



mSDF 250-P3
H3 handle and additional C6 covers



mSD 250-P3
with additional C3 covers

Tabela 5. Accessories

Handle – mounted on the front of the IP54-rated device

Plastic handle for mounting on the front of the device, providing IP54 protection, ON-OFF-T marking, with the possibility of locking with up to three padlocks in the OFF position (on request in the ON position), door interlock in the ON position, with the option



Type	Catalogue No.	Colour	Handle length [mm]	For shaft	Quantity per package [pcs]	Dedicated to
H1	53-040081-001	black	53	□6	1	mSDF80
H2	53-040081-002	yellow and red	53	□6	1	mSDF80
H3	53-040081-003	black	87	□6	1	mSD and mSDF size 80÷315
H4	53-040081-004	yellow and red	87	□6	1	mSD and mSDF size 80÷315



Drive shaft

Type	Catalogue No.	Shaft length [mm]	Shaft dimension	Quantity per package [pcs]	Dedicated to
L150	52-037741-001	150	□6	1	mSD and mSDF size 80÷250
L400	52-037741-002	400	□6	1	mSD and mSDF size 80÷315
L600	52-037741-003	600	□6	1	mSD and mSDF size 80÷315

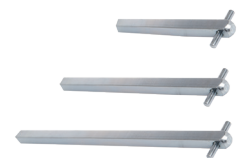

Handle with shaft

A handle with a fixed shaft allows for direct operation of the disconnecter

Type	Catalogue No.	Handle length [mm]	Shaft dimension	Quantity per package [pcs]	Dedicated to
HmSD0	1119510129T	150	□6	1	mSD 80,160,250,315
HmSD1	1119510130T	165	□6	1	mSDF 80,160
HmSD2	1119510131T	180	□6	1	mSDF 250



Terminal cover

The terminal cover provides additional protection for the disconnecter terminals against direct contact

Type	Catalogue No.	Cover length [mm]	Quantity per package [pcs]	Dedicated to
C1	51-008503-001	16	1	mSDF80
C2	51-014681-001	31	1	mSDF80
C3	51-436160-006	46	1	mSDF160, mSD160, mSD250
C4	51-436160-010	95	1	mSDF160, mSD160, mSD250
C5	51-436250-010	54	1	mSDF250 and mSD315
C6	51-436250-011	109	1	mSDF250 and mSD315



Auxiliary contact

Type	Catalogue No.	Functionality	Quantity per package [pcs]	Dedicated to
NO	1115296318T	single, normally open	1	All mSD(F)
NC	1115296319T	single, normally closed	1	All mSD(F)



HOW TO ORDER

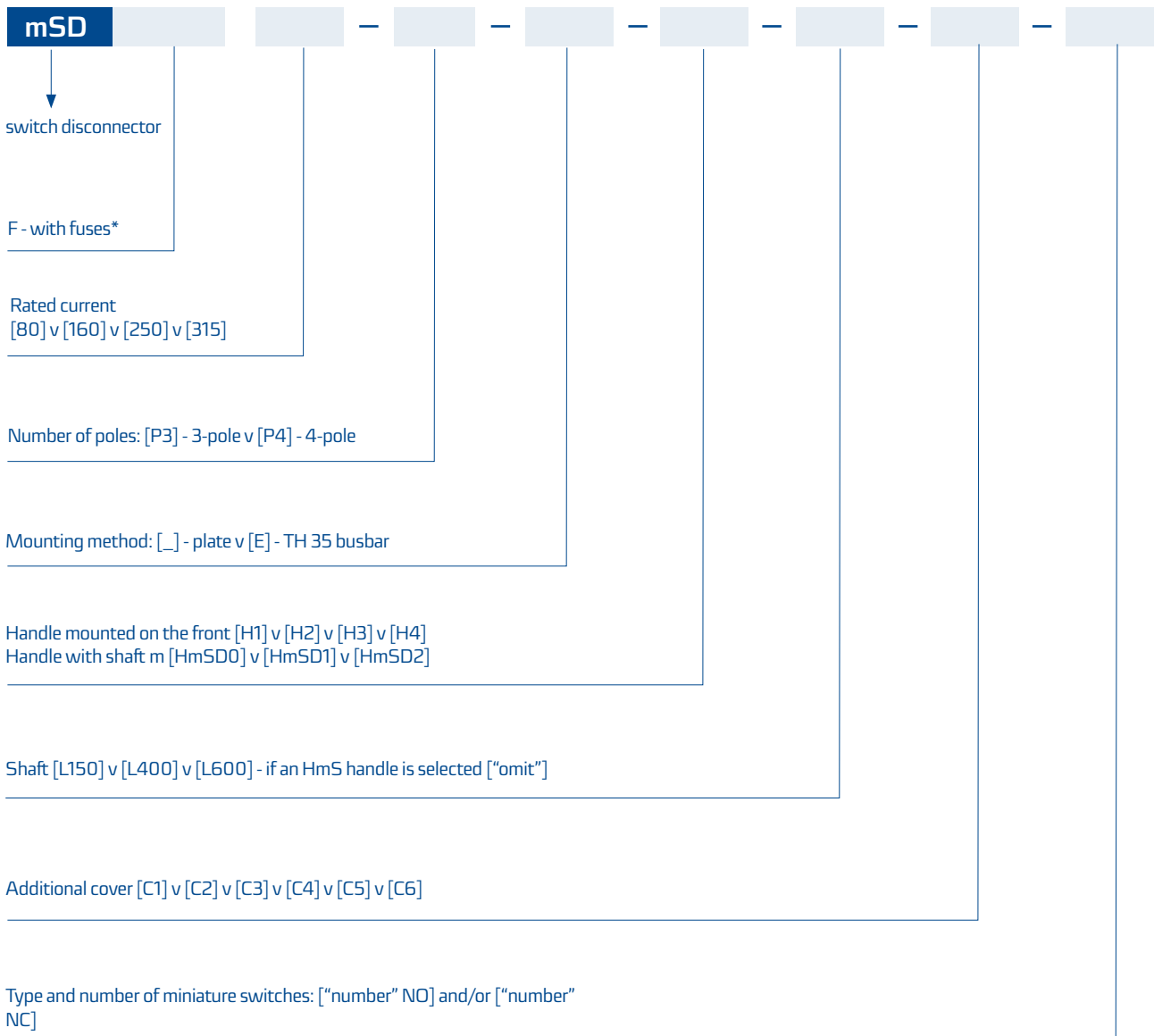

* Fuse switch disconnectors are sold without fuse links

Examples:

mSDF 80-P3-H2-L150-C2-2NO1NC

fuse switch disconnecter, $I_n=80$ A, 3-pole, plate-mounted, with H2 front-mounted handle and a 150 mm shaft, with C2 long covers, including two normally open miniature switches and one normally closed miniature switch.

mSD 250-P3-HmSD0-_-C4-1NO1NC

switch disconnecter, $I_n=250$ A, 3-pole, plate-mounted, with fixed-mounted handle and a 150 mm shaft HmSD0, with long C4 covers, together with one normally open miniature switch and one normally closed miniature switch.

DIMENSIONS with front-mounted handle
mSDF 80

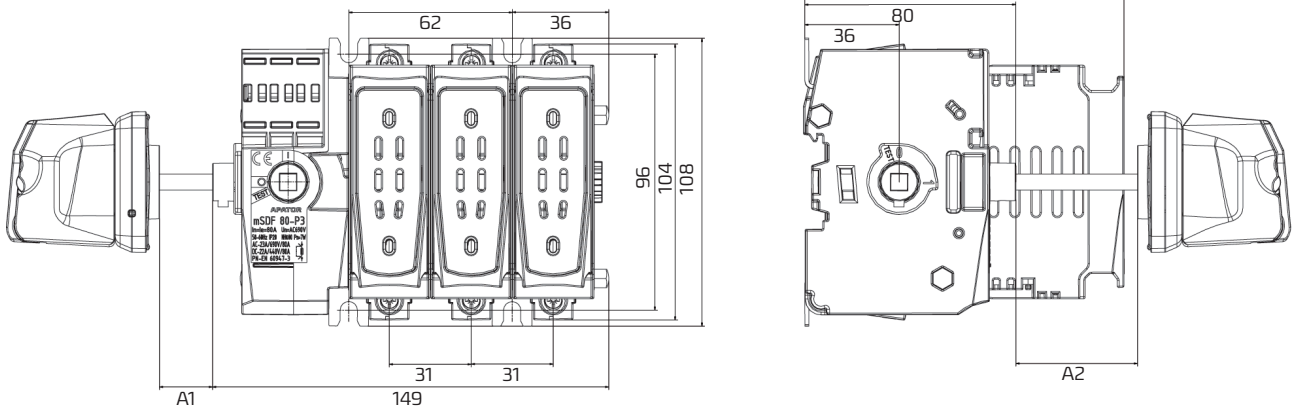

mSDF 80 with short additional cover C1

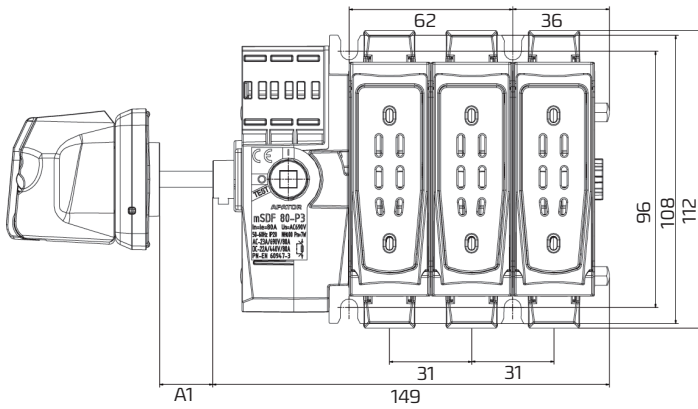

mSDF 80 with long additional cover C2

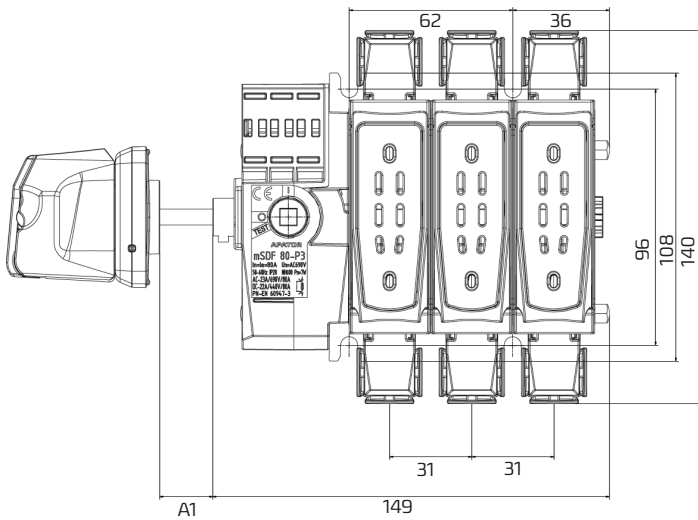

Shaft* [mm]	A1 [mm]	A2 [mm]
150	10÷110	45÷110
400	10÷360	45÷360
600	10÷560	45÷560

*The shaft passing through to the other side of the device should be trimmed

mSDF 160

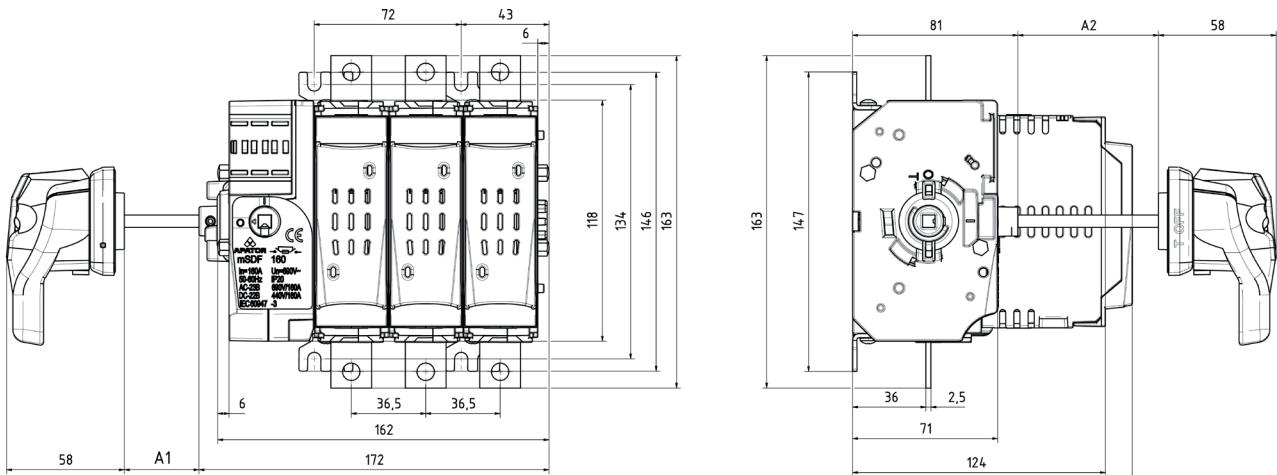

mSDF 160 with short additional cover C3

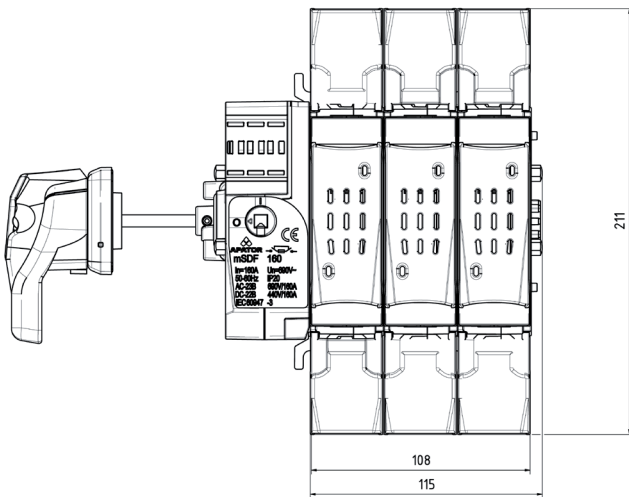

mSDF 160 with long additional cover C4

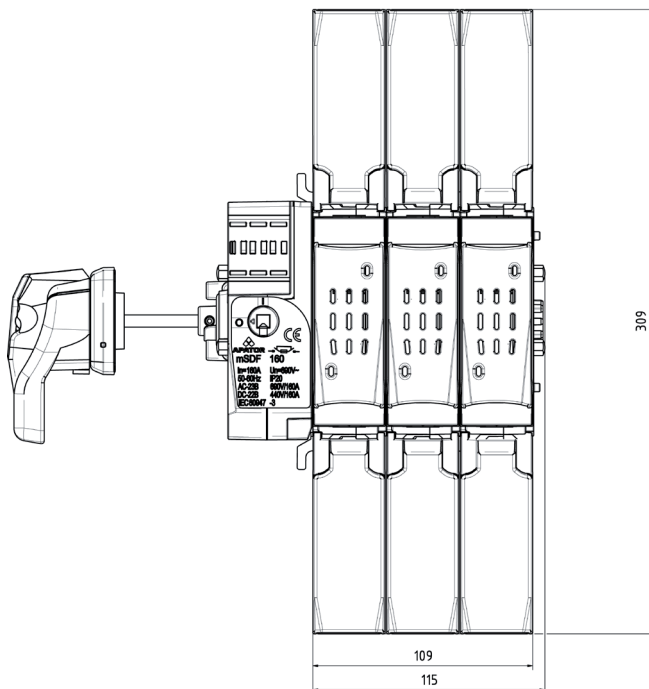

Shaft* [mm]	A1 [mm]	A2 [mm]
150	10÷75	56÷75
400	10÷325	56÷325
600	10÷525	56÷525

*The shaft passing through to the other side of the device should be trimmed

mSD 160 and mSD 250

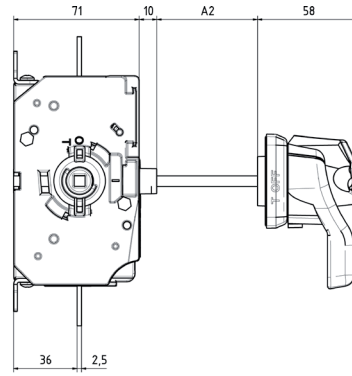
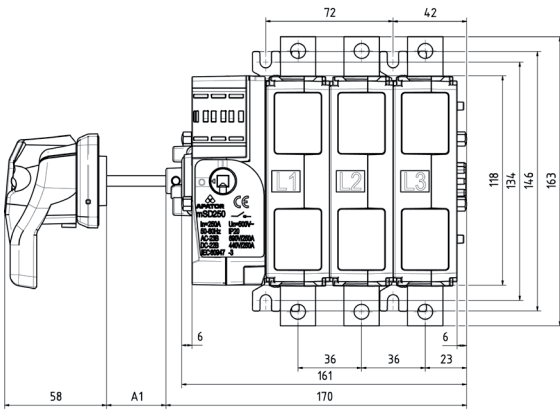

mSD 160 and mSD 250 with short additional cover C3

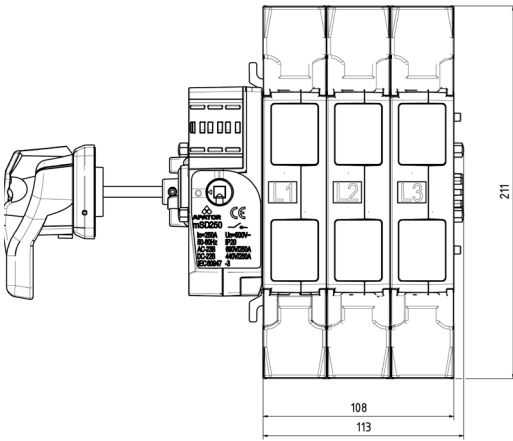

mSD 160 and mSD 250 with long additional cover C4

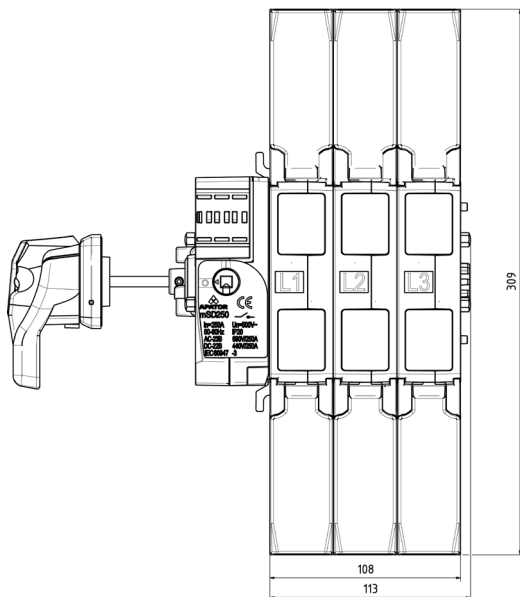

Shaft* [mm]	A1 [mm]	A2 [mm]
150	10÷75	10÷75
400	10÷325	10÷325
600	10÷525	10÷525

*The shaft passing through to the other side of the device should be trimmed

mSD 315

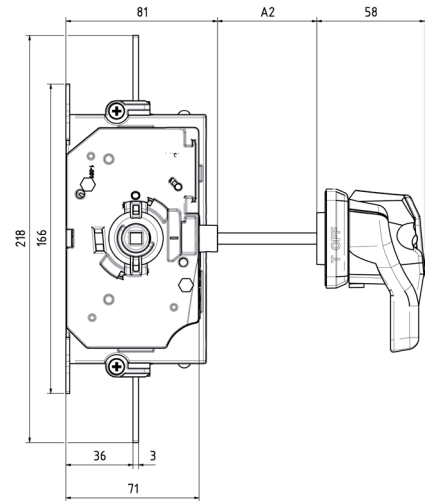
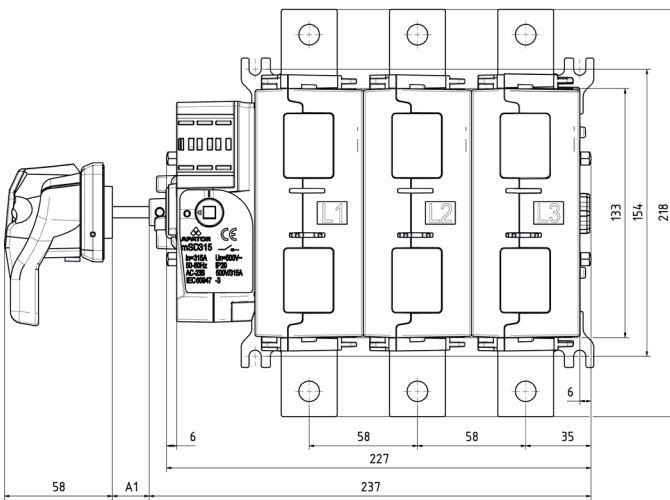

mSD 315 with short additional cover C5

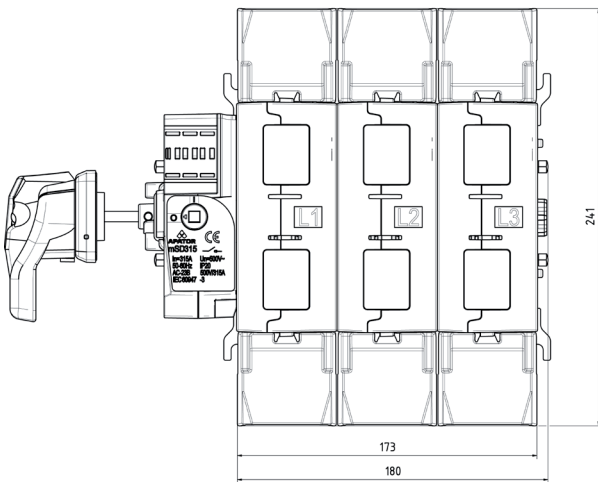

mSD 315 with long additional cover C6

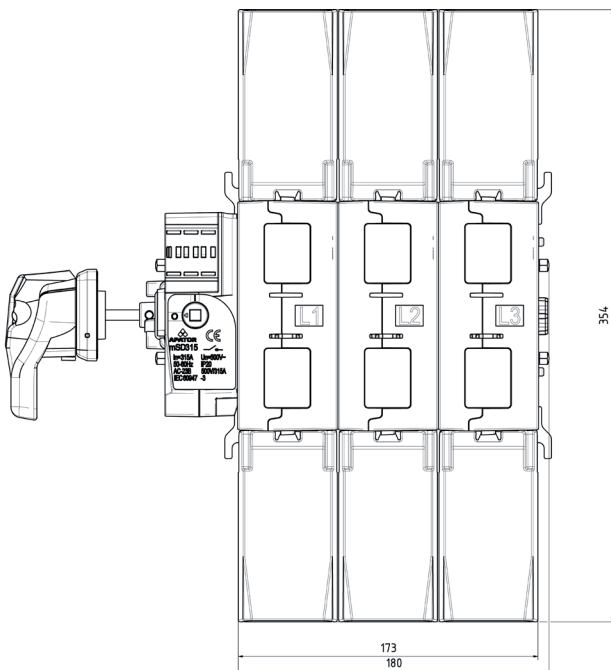

Shaft* [mm]	A1 [mm]	A2 [mm]
150	10÷75	10÷75
400	10÷325	10÷325
600	10÷525	10÷525

*The shaft passing through to the other side of the device should be trimmed

DIMENSIONS with handle and fixed shaft

example: mSDF 250

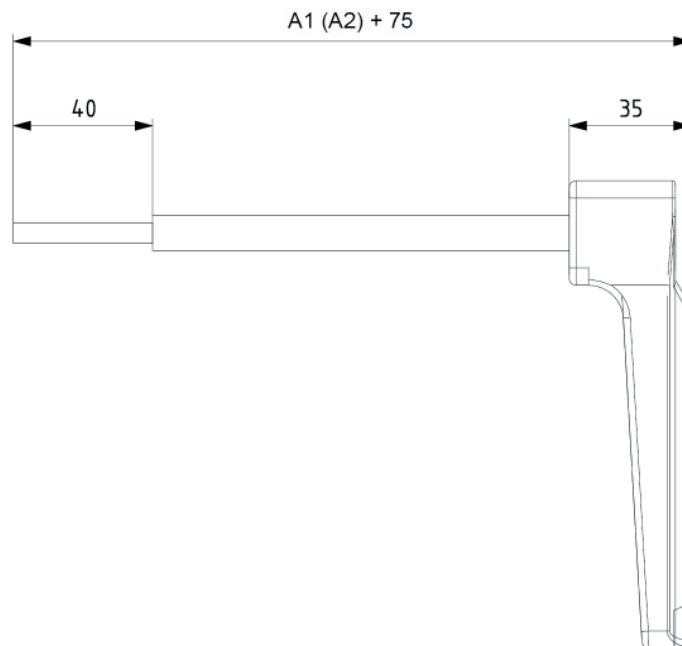
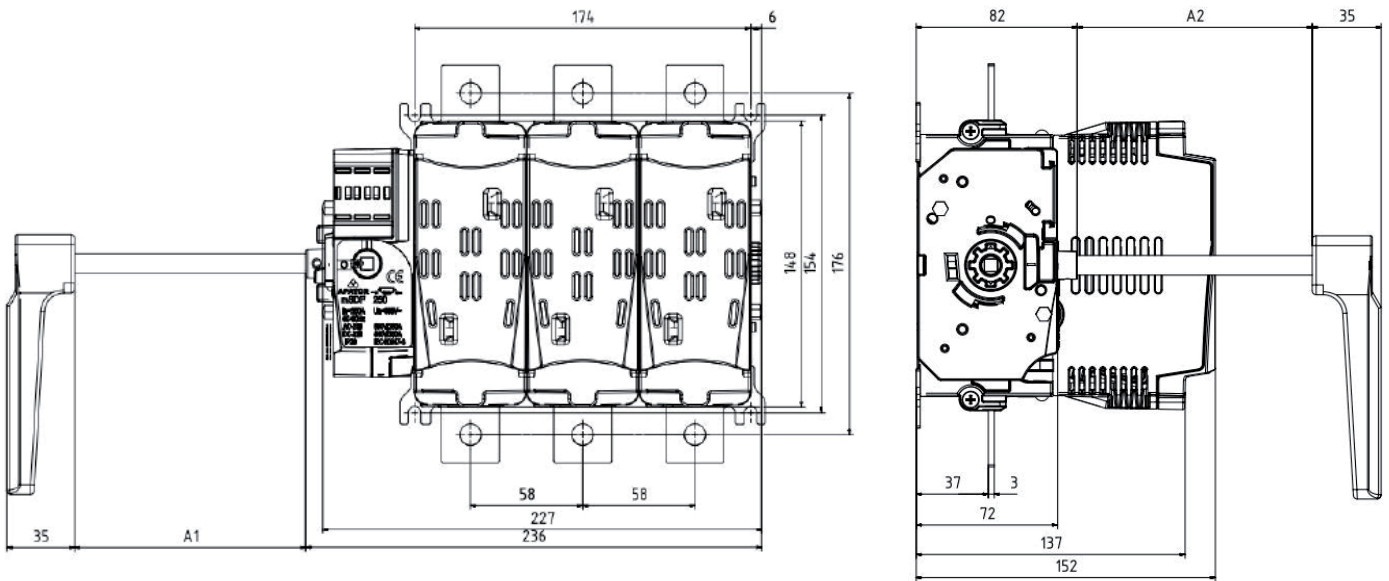

Handle with shaft [mm]	A1 = A2 [mm]
HmSD0 / for mSD 80,160,250,315	49
HmSD1 / for mSDF 80,160	104
HmSD2 / for mSDF 250	119

Handle H1 and H2

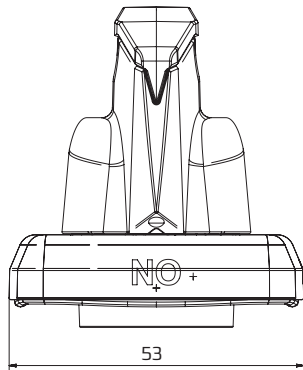
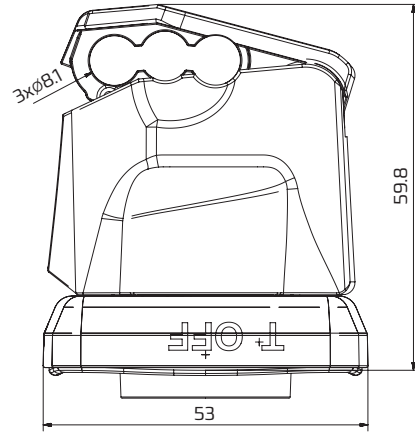
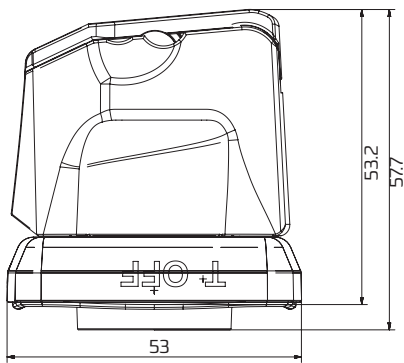

Arrangement of holes for fixing the handle

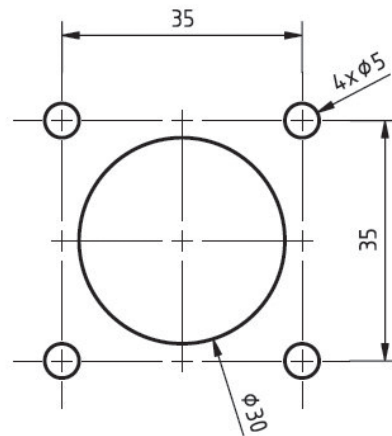

Fixing screws (4 pcs): M4 x h, where h[mm] = 8 + wall thickness

Handle H3 and H4

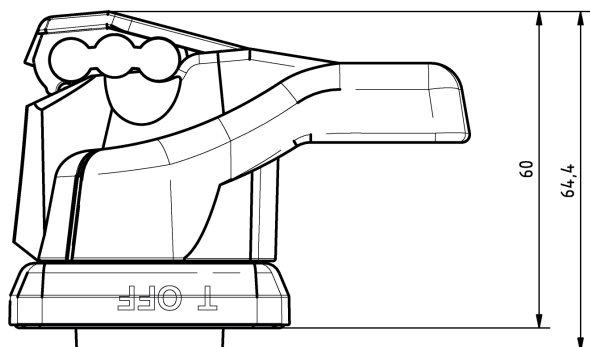
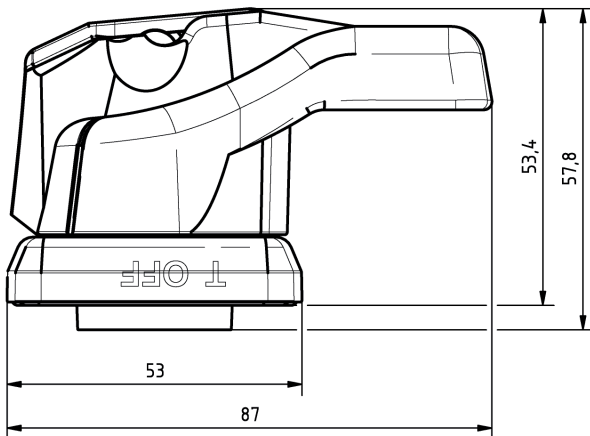

The data presented in the sheet is up-to-date as of the date of issue.
The manufacturer reserves the right to make changes and improvements to the products without prior notice.
This publication has been made exclusively for information purposes and shall not constitute an offer under civil law.

KEY ACCOUNT MANAGER

Rafał Kamiński (English, Russian) Central Europe, South East Europe	rafal.kaminski@apator.com	+48 506 009 338
Michael Roclawski (German, English) Germany, Austria, Switzerland	michael.roclawski@apator.com	+48 506 009 339
Krzysztof Zdrojewski (English) Middle East, South America, Asia, Africa	krzysztof.zdrojewski@apator.com	+48 506 009 309
Jevgenijus Samuchovas (Lithuanian, Russian) Eastern Europe, Baltic Countries	jevgenijus.samuchovas@apator.com	+370 62 842709
Josef Kalleder (Romanian, English) Romania, Rep. of Moldova	josef.kalleder@apator.com	+40 74 5267192

TECHNICAL SUPPORT

Business Development Manager

Łukasz Melkowski (English)	lukasz.melkowski@apator.com	+48 506 009 334
----------------------------	-----------------------------	-----------------



Apator SA

ul. Gdańska 4a lok. C4
87-100 Toruń

Correspondence address:

Apator SA Centrum
Ostaszewo 57C
87-148 Łysomice

tel.: +48 56 61 91 111
fax: +48 56 61 91 295
e-mail: apator@apator.com

Visit us and
like us on Facebook

