



Faun

Precise and reliable, high-quality heat calculator

Faun

FAUN is a high quality, reliable and high class heat calculator designed for measurement of energy in heating and cooling installations. It was developed based on the most up-to-date microcontroller system, innovative technical solutions, design solutions and functional solutions. Its wide communication possibilities allow an easy and correct reading and transfer of measuring data.

Thanks to its high and stable metrological parameters the calculator fulfils the highest requirements and ensures a very accurate energy measurement through the whole operation time.

Application

FAUN is a device designed to be used in installations with water as a heating/cooling factor. It works perfectly in heat distribution centres, residential buildings and functional buildings, industrial buildings etc.

Depending on its design and configuration, the calculator can work as:

- heat meter for heating installation
- heat meter for cooling installation
- heat meter for heating and cooling installation in one circuit.

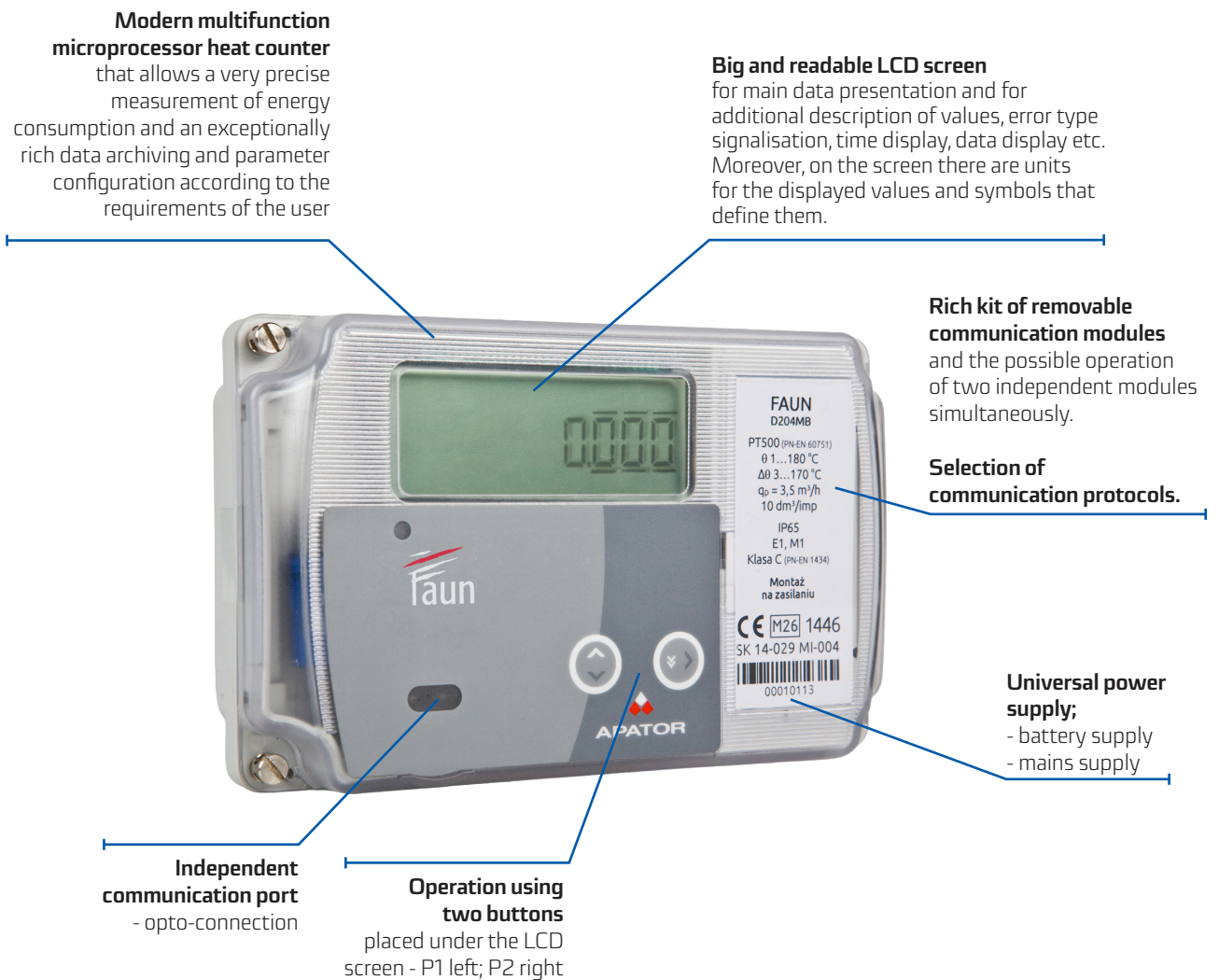

Advantages

Comfort of the user

- Big and readable 8-position display with additional 4-position indicator, many intuitive symbols and units for the displayed values.
- Two buttons that make operation of the calculator much easier (mechanical or capacitive version).
- Possibility of individual configuration of the calculator according to particular requirements, configuration of parameters, functions, communication, type and range of data displayed on LCD through a dedicated program (on PC).
- Possibility of manual configuration of some parameters of the calculator using the buttons.
- Possibility of mounting (without legalisation infringement) two independent communication modules and a selection of communication protocols.

Safety of the user

- Independent registers for archiving in non-volatile measuring data memory, failures and occurrences, non-metrological and metrological configuration changes.
- Secured various permission levels for changing the configuration: user jumper, legalization jumper, HASP dongle for dedicated software.
- Three levels of housing protection that ensure the required tightness even in the most difficult operating conditions: IP54, IP65 and IP68 (the only such protection degree available on the market, only in Faun calculator).

Functional options

- Possibility of cooperation with heat transducers with ultrasound or rotor impulse output available on the market.
- Possibility of cooperation with temperature sensors Pt100 or Pt500, in a 2 or 4-wire system.
- Possibility of installation directly on flow transducers*.
- Environmental class C (M1, E1).
- Independent opto-connection.
- Power supply versions: battery (possible application of various types of batteries, battery life 6 or 12 years) or internal power supply 230 VAC.
- In standard version 4 configurable impulse inputs (additional possibility of functional change into alarm inputs or inputs for digital communication with a transducer).
- More than 5000 registers of measuring data archiving, to be configured by the user.
- Two independent tariff registers (superliminal registers), possible configuration of the following thresholds: power, flow, power supply temperature, return temperature, temperature difference, tariff data archiving.
- Independent registers of occurrences and failure modes, configuration changes.
- Additional digital communication with ultrasound transducer that identifies the transducer errors, among others the return flow, weaker measuring signal, air-locks.
- Dedicated software (for PC) for the configuration of parameters of the calculator and for the reading of all current and archived data.

*applies for Sharky 473 transducers offered in heat meters kits

Functions of the calculator

- Measurement and indication of current data, instantaneous.
- Calculation and indication of data for averaging period, set in the range 1-1440 minutes (24 hours).
- Calculation, archiving, indication of measuring data in 5 groups with time cycles*:
 - minutes cycle – data record period configurable in the range 1-21600 minutes (two weeks),
 - hours cycle – set record period, at the beginning of every full hour,
 - 24 hours cycle – set record period, once per 24 hours at selected hour,
 - monthly cycle – set record period, once per month at selected full hour on the selected day of the month,
 - yearly cycle – set record period, once per year at selected full hour on the selected day and month.
- Setting, archiving and indicating the tariff data (possible activation of two independent tariffs*).
- Setting, archiving and indicating the accounting data (possible setting of date and time of data record for accounting independent from the settings of other registrations*).
- Archiving of emergencies (83 last records) and occurrences (256 last records) with the exact time of occurrence, retreatment and duration time of each of them.
- Archiving of configuration changes by the user (83 last records) and changes of metrological configuration (62 last records) with the exact time of each change and the record of settings before a change.
- Configuration of calculator parameters using the dedicated software or in a narrower range using the buttons.

Removable communication modules

- M-Bus.
- RS232.
- RS485.
- Impulse outputs (2 outputs).
- Impulse outputs and inputs (2 outputs class OB, OC, or OD and 2 inputs class IB or IC).
- Analogue outputs (2 outputs, 4-20 mA or 0-10 V).
- LonWorks.
- Radio module Wireless M-Bus.
- Radio module for telemetric systems IMR.

Communication protocols

- M-Bus in conformity with: PN-EN 13757-2:2005, PN-EN 13757-3:2013.
- Modbus in conformity with specification Modbus RTU.
- Lumbus.
- LonWorks.
- Cooperates with devices working in OMS standard.

*Archiving of the above-mentioned data in the memory of the calculator is configurable. It is possible to select data for the record and to set the number of registrations for each group (cyclical records, tariff records, for the purpose of accounting) choosing from the general possible number (more than 5000) of such records.

Operation of the calculator

Buttons

The calculator is operated using two buttons P1 and P2, each of them has two functions activated through a quick click (marked with dark arrow) or by pushing the button for about 2 seconds (marked with light arrow).





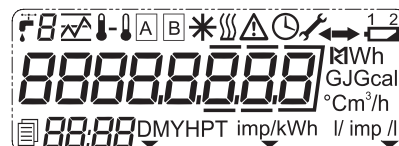

LCD screen

On the display there are two result fields – one 8-digit field for quantity data display and the other field, depending on the displayed screen, for additional description of quantities, error type signalisation or e.g. for time display on the screen with date and hour. Moreover, on the display there are units for the displayed values and intuitive symbols that define them.



Selected symbols

Important and common symbols displayed on the screens when a given occurrence appears are:

-  symbol that displays the volume or flow values
- cold symbol displayed for the values of cold registers *
- emergency symbol  that signalises a failure, displayed on the main screen and on the screens that are connected with the given failure
- time symbol  displayed for the value of current date and time
- key symbol  that signalises the access to the configuration of calculator – displayed on all screens when unlocking the access
- return flow symbol – flow at variance with the right direction 
- flow symbol – flow in the right direction 
- battery empty symbol  displayed on all screens when battery voltage falls below the minimum value

Menu groups

1. Main group – enables the display of current main values of main registers of the calculator and of the measured instantaneous values.
2. Statistic group – contains average data and the highest data for averaging period.
3. Service group – enables the display of selected data of the calculator's configurations, among others the settings of main input and additional inputs, settings of additional modules, current date and time, operating time etc. The group is divided into three sub-groups with configuration data of the calculator, additional inputs/outputs and younger energy digits from the main group.
4. Tariff group – enables the display of current data from tariff registers, exceeding time and threshold value, and the archived tariff data, register's values of the calculator at the moment of retreat, exceed of tariff threshold.
5. Archive group – enables the display of archived data from cyclic archives, the data for each archive are placed in sub-groups of the registers: minute groups, hour groups, month groups, year groups and accounting groups.
6. Configuration group – enables the configuration of selected parameters of the counter.

Navigation in the calculator's menu

- Button P1 – is used above all for navigation between the elements in a given group and sub-group (vertical navigation in menu):
 - quick click of the button jumps to the next element in the group/sub-group or enters the group/sub-group
 - pushing the button longer enables the exit from the group/sub-group
- Button P2 – is used for navigation between the groups and sub-groups (horizontal navigation in menu):
 - quick click of the button in case of the display of group selection screen jumps to the next group/sub-group, in case of display of selected quantity values it takes the shortcut and jumps directly to the value from a different group, which is connected to the displayed value
 - pushing the button longer causes the activation of optical port and is used to confirm the change of settings from the calculator level (in group 06)

Main group 01	Statistic group 02	Service group 03	Service group 03 • Sub-group I/O • Sub-group Regs (younger energy digits)	Tariff group 04 *	Archive group 05 Sub-groups of the archive: yearly, monthly, 24 hours, hours, minutes, accounting	Configuration group 06 **
<ul style="list-style-type: none"> • Energy • Additional energy (cooling) • Energy tariff 1 • Energy tariff 2 • Main volume • Additional volume • Volume tariff 1 • Volume tariff 2 • Power supply temperature • Return temperature • Temperature difference • Instantaneous flow • Instantaneous power • Error code • In1 • In2 • In3 • In4 • Metrological test • Display test 	<ul style="list-style-type: none"> • Average flow, max, min • Average power, max, min • Average power supply temperature max, min • Average return temperature max, min • Average temperature difference max, min 	<ul style="list-style-type: none"> • Meter • Manufacturer's number • Customer number • Network address • Impulse main weight • Mounting place, operation type • Date and time • Software version • Production date • Operating time • Error operating time • Cooling energy measurement threshold • Record time in accounting archive • Error threshold of exceeded flow • Error thresholds of lacking flow • Battery voltage 	<ul style="list-style-type: none"> • I/O • Configuration of additional inputs in1, in2, in3, in4 • Type and configuration of installed communication modules • Configuration of optical-connection • Younger digits of: energy, additional energy, energy tariff 1, energy tariff 2 	<ul style="list-style-type: none"> • Energy tariff 1 • Volume tariff 1 • Operating time in tariff 1 • Threshold type tariff 1 • Threshold value tariff 1 • Energy tariff 2 • Volume tariff 2 • Operating time in tariff 2 • Threshold type tariff 2 • Threshold value tariff 2 • Tariff archive • Record number • Time of threshold occurrence • Time of threshold retreat • Tariff energy • Tariff volume • Operating time in a tariff 	<ul style="list-style-type: none"> • Record number • Energy • Energy tariff 1, 2 • Volume tariff 1, 2 • Additional energy • Additional volume • Error code • Instantaneous: flow, power, power supply temperature, return temperature, temperature difference • Flow (average, max, occurrence time max, min, occurrence time min) • Power (average, max, occurrence time max, min, occurrence time min) • Power supply temperature (average, max, occurrence time max, min, occurrence time min) • Return temperature (average, max, occurrence time max, min, occurrence time min) • Temperature difference (average, max, occurrence time max, min, occurrence time min) • In1, in2, in3, in4 • Operating time • Error operating time 	<ul style="list-style-type: none"> • Year, month, day, hour, minute • Customer number • Network address • Type: in1, in2, in3, in4 • Impulse constant: in1, in2, in3, in4 • Initial state: in1, in2, in3, in4 • Manufacturer's number: in1, in2, in3, in4 • Confirmation of introduced changes

Each of displayed positions marked with blue colour can be turned off using the calculator configuration program

* Group 04 appears when the threshold for a given tariff is turned on (positions that concern the active tariff are displayed)

** Group 06 appears when the configuration possibility is active (after using

Table 1. TECHNICAL DATA

Basic operating parameters of the calculator			
Energy unit	–		GJ, MWh, kWh or Gcal
Volume unit	–		m ³
Temperature range	°C		$\theta_{\min} = 1^{\circ}\text{C}$ $\theta_{\max} = 180^{\circ}\text{C}$
Temperature difference range	°C		$\Delta\theta_{\min} = 3^{\circ}\text{C}$ $\Delta\theta_{\max} = 175^{\circ}\text{C}$
Nominal flow range	m ³ /h		0,6 ... 3 000
Impulse constant range for flow transducer	dm ³ /imp		1 ... 10 000
	imp/dm ³		0,01 ... 300
Maximum permissible error MPE	%		$E_c = \pm (0,5 + \Delta\theta_{\min} / \Delta\theta)$
Cooperating temperature sensors	–		- Pt 500 - 2 or 4-wire measurement*
Cooperating flow transducers	–		Ultrasound or rotor transducers
Switching for cold measurement when operating in heating and cooling installation in one circuit	–		Supply temperature < return temperature and power supply temperature below the set value
Communication	–		optical port, configurable transmission speed from 300 Bd to 9600 Bd; 2 replaceable communication modules
Power supply	–		Lithium battery 3,6 V type: AA, 2xAA, G or D or plug in power supply 230 VAC
Battery life	years		6-12 years, depending on battery type
Environmental class	PN-EN 1434	–	C
	MID	–	E1, M1
Ambient temperature	°C		5 ... 55
Protection degree	–		IP54 or IP65 or IP68

Other parameters of the calculator			
Display type	–		LCD 8 main digits, 4 additional digits, graphic symbols
Indication change	–		Two buttons: mechanical or capacitive
Maximum range of energy counter	GJ		99 999,999 ... 99 999 999
	Gcal		99 999,999 ... 99 999 999
	kWh/MWh		9 999 999,9 kWh ... 9 999 999,9 MWh
Maximum range of volume counter	m ³		99 999,999 ... 99 999 999
Maintenance of the calculator's power supply (after the loss of main supply)	–		Lithium battery 3,6 V 1/2 AA or CR 3 V battery or super-cap
Maximum frequency of impulses for the main input	imp/dm ³	Hz	< 150
	dm ³ /imp		< 22
Maximum frequency of impulses for additional inputs	Hz		< 3
Maximum length of cables for impulse inputs	m		15
Maximum diameter of connecting cables	mm ²		2,5 (max outside diameter of the cable 5,5 mm)
Number of main inputs	szt.		1
Maximum number of additional inputs	szt.		4
Storage temperature	°C		– 25 ... + 60
Housing material	–		polycarbonate (PC)
Housing size, length/width/height	mm		159/100(123)*/46,5
Weight without the battery	kg		0,35
Mounting of the calculator	–		On the wall (mounting handle provided) or on the flow transducer*

* applies for Sharky 473 transducers offered in heat meters kits

Dimensions and mounting

View and housing sizes in IP54 version

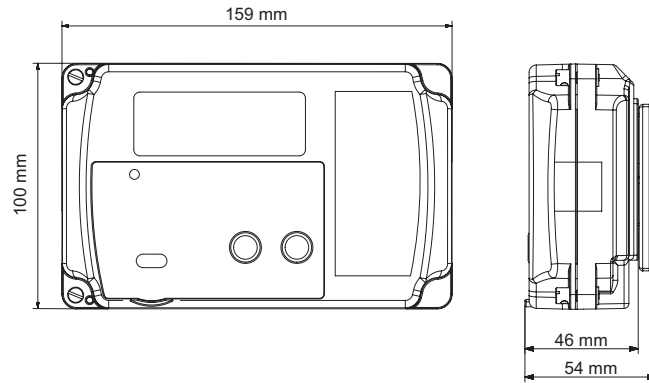

View and housing sizes in a version

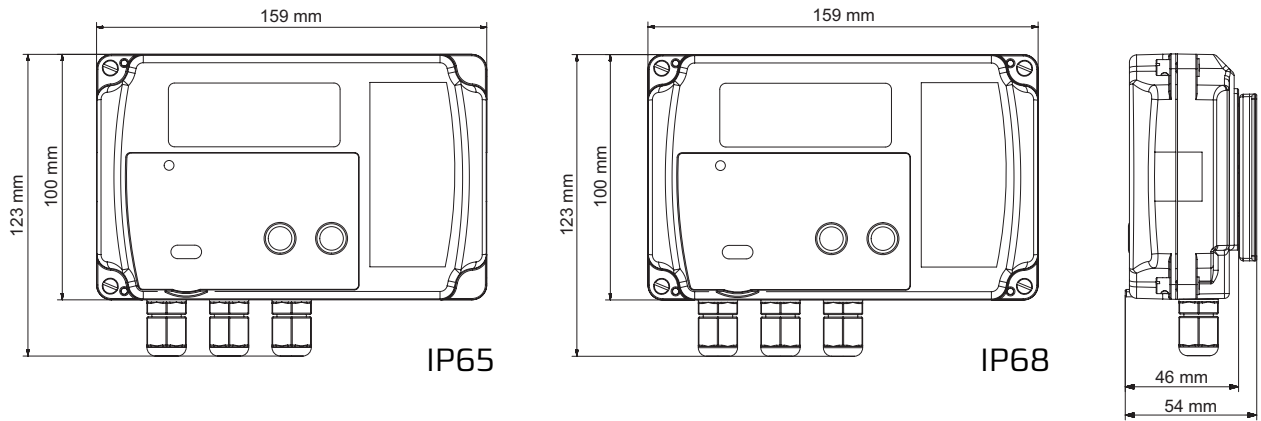

Mounting of the calculator on the wall

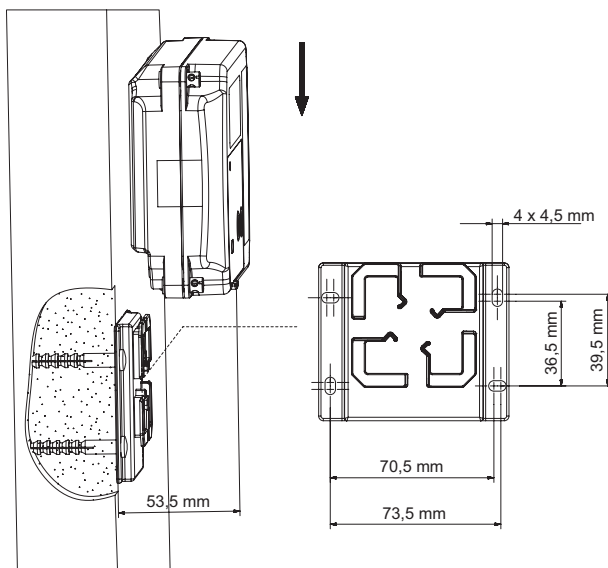

Mounting of the calculator with a transducer

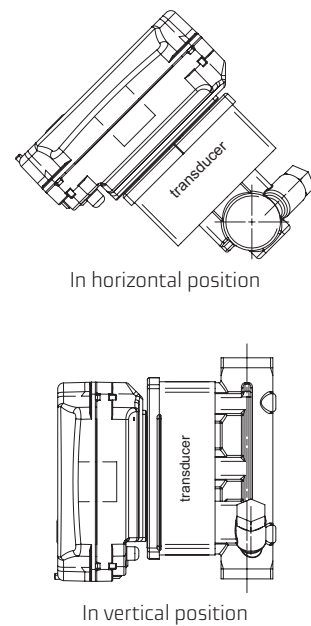

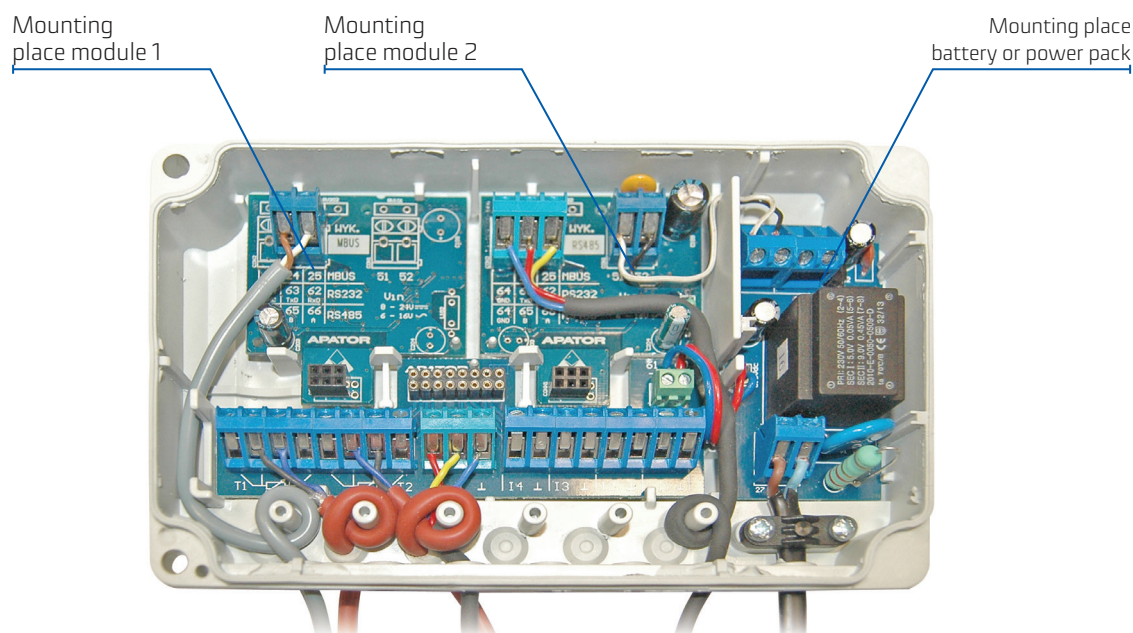

View of the base with connecting binding, with installed communication modules and plug-in power supply as well as the way of leading the cables in IP54 version.

Conformity with the norms

The calculator is in conformity with the following norms:

- PN-EN 1434 – heat meters, 6 parts
- PN-EN 13757 – communication system for remote reading of measuring devices indications, parts 1–4
- OIML R75 – international recommendation, heat meters,
- WELMEC 7.2 – software guide (Measuring Instruments Directive 2004/22/EC),
- WELMEC 11.1 – guide for Measuring Instruments Directive 2004/22/EC, common application for utility meters.

Order

In order to buy the right FAUN calculator please provide us with necessary data:

- Operation in:
 - heating installation,
 - cooling installation,
 - heating and cooling installation in 1 circuit.
- Mounting place of flow transducer: power supply / return
- Flow transducer type (mechanical or ultrasound)
- Impulse weight, nominal flow of flow transducer
- Temperature sensors type: Pt100 or Pt500
- Temperature measurement type: 2 or 4-wire
- Type and weight of impulses of additional inputs
- Type of communication modules, no. 1 and 2
- Power supply type – battery or plug-in power supply

Example: FAUN – for heating installation, mounting in the return, ultrasound transducer, 10l/imp, $Q_n=6\text{m}^3/\text{h}$, Pt500, 4-wire, in1 water meter 1l/imp, in 2 water meter 10l/imp, module no.1 M-Bus, module no. 2 – none, battery powered

The data presented in the data sheet was correct on the date of publication.
The manufacturer reserves the right to modify and improve its products without notice.
This publication is intended for information purposes only and shall not be construed as a commercial offer under the Polish Civil Code.



Apator Powogaz S.A.

Jaryszki 1c, 62-023 Żerniki, Poland

Office: sekretariat.powogaz@apator.com, tel. +48 61 84 18 101

Sales / Customer Service: tel.: +48 61 84 18 149

Customer Service Centre Support: handel.powogaz@apator.com

Export: export.powogaz@apator.com

Technical Support: support.powogaz@apator.com, tel. +48 61 8418 131, 134, 294

Warranty Claims: reklamacje.powogaz@apator.com