

Installation and operating instructions

Flanged water meters, DN40–500 IP68/IP65

Irrigation water meters, DN40–250 IP68/IP65



JS Impero



MWN Nubis



MK



MH



MWN/JS-S coupled



WI

ISO 9001

ISO45001

ISO 14001

Contents

1. Subject.....	3
2. Technical data – standards and regulations	7
3. Operating principle of water metres / irrigation water meters	8
4. Selection of a water meter	8
5. Selection of a meter for irrigation water	9
6. Delivery inspection.....	10
7. Water meter installation requirements	11
8. Irrigation water meter installation requirements	13
9. Priming with water, commissioning, and operation of the water meter / irrigation water meter	15
10. Storage and transport	15
11. Troubleshooting	15
12. Safety and environmental requirements	15
13. Pulse output value and installation diagrams for water metres / irrigation water meters.....	16
14. Disposal of waste products and packaging	18
15. Your feedback.....	18

1. Subject

This installation and operating instructions applies to DN40-500* water meters with flanged ends and DN40-250* irrigation water meters, manufactured by Apator Powogaz S.A. in compliance with the procedures of its Integrated Quality, Environment and Safety Management System. Apator Powogaz S.A. recommends that you read the manual carefully before installing the meters. This will help to ensure compliance with their intended use.

This manual specifies the criteria for proper selection, conditions for correct installation, operation and maintenance, as well as the principles regarding safety, environmental protection and disposal of the following measuring devices: flange water meters for measuring the volume of potable water and water used for economic and industrial purposes, and meters for irrigation water for measuring water taken from surface water intakes or sewage discharge from sewage treatment plants flowing in closed conduits (pipelines).

* **Important!** MWN400 and MWN500 water meters and DN40-250 irrigation water meters are outside the applicability of MID (the EU measuring instrument directive) and legal regulations which are mandatory to all other meters specified in this manual.

Table 1. Types and applications/design of flanged water meters or irrigation water meters.

Type – Version	Applications/design
<p>JS Impero (DN50-100) – single-jet, dry-running vane-wheel</p> <p>MWN Nubis (DN40-500) – horizontal rotor axis propeller</p> <p>MK (DN50-150) – chamber-mount, vertical rotor axis propeller</p> <p>MH (DN50-65) – hydrant, vertical rotor axis propeller</p> <p>MWN/JS-S (DN50-150) – coupled, with spring-action valve</p>	<ul style="list-style-type: none"> ▪ Cold water: min. 0.1°C – max. 50°C ▪ Max operating pressure – 1.6 MPa (16 bar) ▪ IP68 – hermetic counter (with #UTIP* connector, compatible with induction transmitter modules) ▪ IP65 – hermetic counter, compatible with optical transmitter modules
<p>MWN130 (DN40-300) – horizontal rotor axis propeller</p>	<ul style="list-style-type: none"> ▪ Hot water – max. 130°C ▪ Max operating pressure – 1.6 MPa (16 bar) ▪ IP65 – hermetic counter, compatible with optical transmitter modules
<p>WI (DN40-250) – irrigation water meter</p>	<ul style="list-style-type: none"> ▪ Cold water: min. 0.1°C – max. 30°C ▪ Max operating pressure – 1.6 MPa (16 bar) ▪ IP68 – hermetic counter (with #UTIP* connector, compatible with induction transmitter modules)

<p>JS Impero NKOP (DN50-100) – single-jet, dry-running vane-wheel, compatible with NK and NO transmitters</p> <p>MWN NKOP (DN40-400) – propeller, compatible with NK and NO transmitters</p> <p>MK NKOP (DN50-150) – propeller, compatible with NK and NO transmitters</p> <p>MWN/JS-S NKP (DN50-150) – coupled, compatible with NK transmitter modules</p>	<ul style="list-style-type: none"> ▪ Cold water: min. 0.1°C – max. 50°C ▪ Max operating pressure – 1.6 MPa (16 bar) ▪ NKOP – adaptation of the water meter counter (IP65) for mounting the NK and/or NO transmitter <ul style="list-style-type: none"> <input type="checkbox"/> NK – reed switch transmitter <input type="checkbox"/> NO – optoelectronic transmitter ▪ NKP – adaptation of the water meter counter (IP65 or IP68) for mounting the NK transmitter
<p>MWN130 NKP (DN40-300) – propeller, compatible with NK transmitters</p>	<ul style="list-style-type: none"> ▪ Hot water – max. 130°C ▪ Max operating pressure – 1.6 MPa (16 bar) ▪ NKP – adaptation of the water meter counter (IP65) for mounting the NK transmitter <ul style="list-style-type: none"> <input type="checkbox"/> NK – reed switch transmitter
<p>WI NKP (DN40-250) – irrigation water meter, compatible with NK transmitters</p>	<ul style="list-style-type: none"> ▪ Cold water: min. 0.1°C – max. 30°C ▪ Max operating pressure – 1.6 MPa (16 bar) ▪ NKP – adaptation of the water meter counter (IP65) for mounting the NK transmitter <ul style="list-style-type: none"> <input type="checkbox"/> NK – reed switch transmitter

* #UTIP – Universal TI Plug – direct module installation on the IP68-rated water meter.

Table 2. Installation positions.

Water meter / irrigation water meter type	Installation positions* of the water meter / irrigation water meter	
	Horizontal with the counter pointing upwards – H	Horizontal or vertical with the counter pointing sideways – V
JS Impero	✓	-
MWN Nubis MWN130 Nubis	✓	✓
MWN/JS-S	✓	-
MK	✓	-
MH	✓	-
WI	✓	✓

* The installation orientation tolerance of the medium flow axis for all meters – installed horizontally, vertically or at any angle between H and V – should be $\pm 5^\circ$ as specified in EN ISO 4064-2.

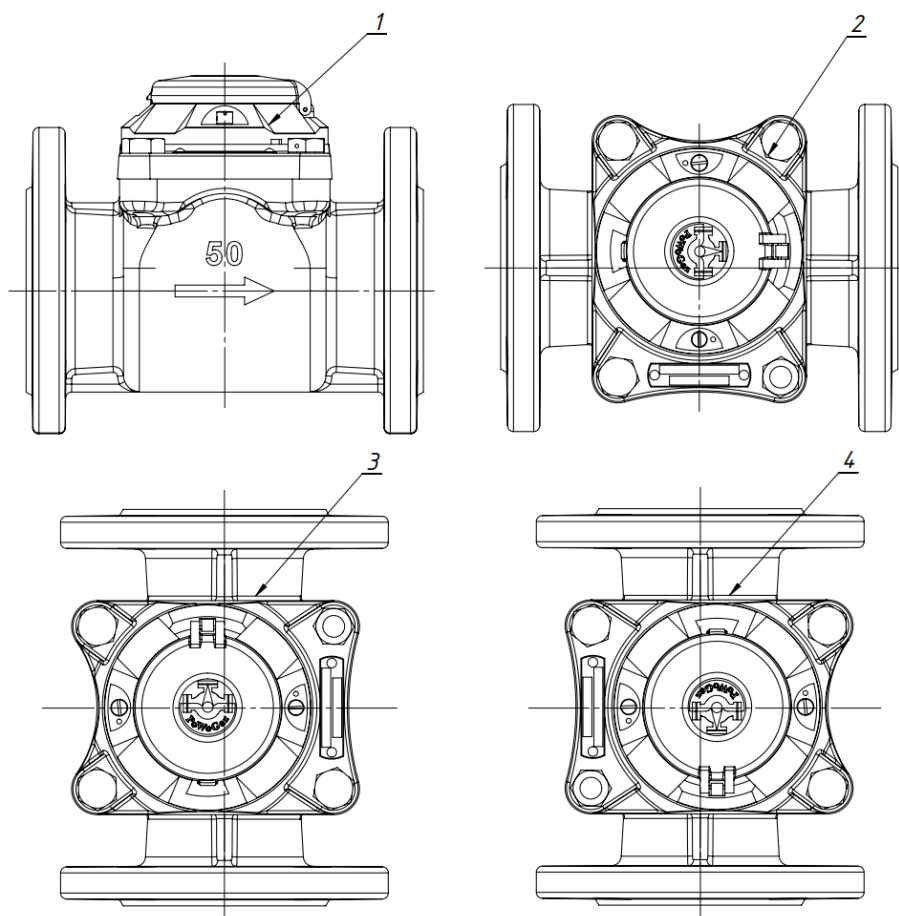

- 1 – Horizontal with the counter pointing upward – H
- 2 – Horizontal with the counter pointing sideways – V
- 3 – Horizontal with the counter pointing sideways – V, water flow inlet from the bottom
- 4 – Horizontal with the counter pointing sideways – V, water flow inlet from the top (not recommended)

Fig. 1. Examples of permissible installation positions of water meters manufactured by Apator Powogaz S.A.

Example markings of the MWN Nubis water meter:

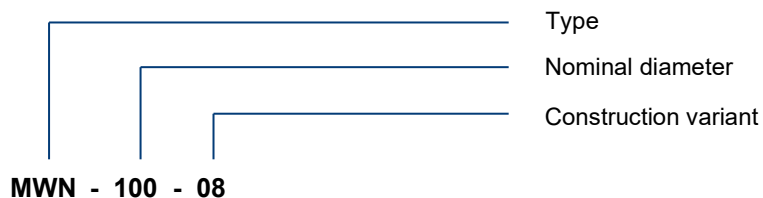

Example markings of the MWN130 Nubis water meter:

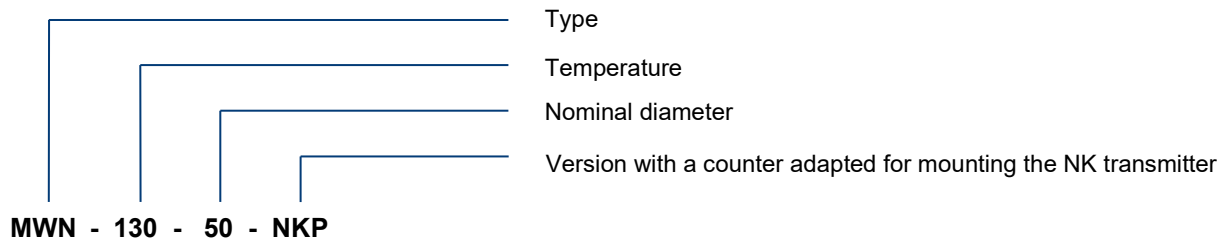

Example markings of the MWN/JS coupled water meter:

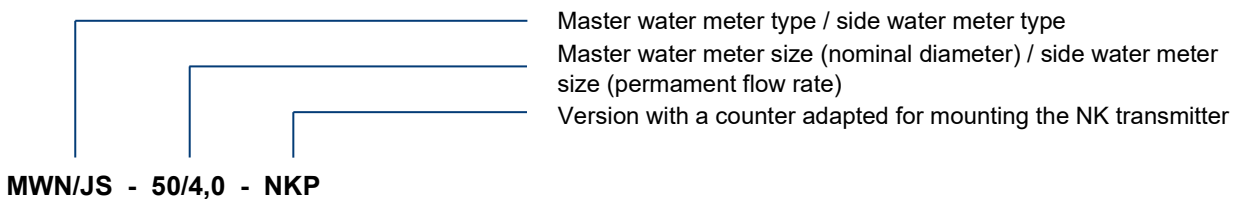

Table 3. Values of the permanent flow rate Q₃ for a particular type of water meter.

Water meter diameter [mm]	Water meter / irrigation meter type						
	JS Impero	MWN Nubis	MWN130	MK	MH	MWN/JS	WI
	Permanent flow rate Q ₃ [m ³ /h]						
40	-	25	25	-	-	-	25
50	25 (50*)	40	25	25	25	25	25
65	40 (60*)	63	40	-	40	40	40
80	63 (90*)	100	63	63	-	63	63
100	100 (135*)	160	100	100	-	100	100
125	-	250	160	-	-	-	160
150	-	400	250	250	-	250	250
200	-	630	400	-	-	-	400
250	-	1000	630	-	-	-	630
300	-	1600	1000	-	-	-	-
400**	-	According to parameters specified by the producer	-	-	-	-	-
500**	-		-	-	-	-	-

* Maximum momentary ("fire") flow < 2 h.

** On special request.

2. Technical data – standards and regulations

Technical data are included in the catalog cards for each type of water meter / irrigation water meter.

Water meters meet the requirements of standards and regulations:

1. Directive 2014/32/EC of the European Parliament and of the Council of 26 February 2014 on the harmonisation of the laws of the Member States relating to the making available on the market of measuring instruments.
2. Polish Act of 13/04/2016 on market surveillance and compliance assessment systems.
3. OIML R 49-1:2013 – Water meters intended for the metering of cold potable water and hot water. Part 1: Metrological and technical requirements.
4. OIML R 49-2:2013 – Water meters intended for the metering of cold potable water and hot water. Part 2: Test methods.
5. OIML R 49-3:2013 – Water meters intended for the metering of cold potable water and hot water. Part 3: Test report format.
6. OIML D 11:2013 (E) General requirements for measuring instruments – environmental conditions.
7. EN ISO 4064-1:2017 – Water meters for cold potable water and hot water. Part 1: Metrological and technical requirements.
8. EN ISO 4064-2:2017 – Water meters for cold potable water and hot water. Part 2: Test methods.
9. EN ISO 4064-5:2017 – Water meters for cold potable water and hot water. Part 5: Installation requirements.
10. EN ISO 4064-4:2014 – Water meters for cold potable water and hot water. Part 4: Non-metrological requirements not covered in ISO 4064-1.
11. Polish Regulation of the Minister of Development dated 02 June 2016 and concerning requirements for measuring instruments.
12. Polish Regulation of the Minister of Entrepreneurship and Technology dated 22 March 2019 concerning legal metrological control of measuring instruments.
13. PN-B- 10720 - Waterworks. Installation of water meter sets in water supply systems. Acceptance requirements and tests.

The irrigation water meters meet the following standards and regulations:

14. PN-EN 14268 – Meters for irrigation water.
15. Hygiene Certificate.

3. Operating principle of water metres / irrigation water meters

The **JS Impero** water meter comprises a metering unit and counter mechanism. The flow of water passing through the water meter drives the vane wheel installed in the metering unit. The vane wheel axis is perpendicular (vertically oriented) to the body bore centreline. The magnet in the wet section of the water meter is coupled to the counter magnet installed in the dry section of the water meter. A system of gears drives the pointers and barrels of the water meter, which then indicates the measured flow of water.

The **MWN Nubis** water meter comprises a body, metering unit, and counter mechanism. The flow of water passing through the water meter drives the propeller installed in the metering unit. The propeller is co-axial to the body bore and rotates a magnet on an axle via a worm and wheel transmission. The magnet in the wet section of the water meter is coupled to the counter magnet installed in the dry section of the water meter. A system of gears drives the pointers and barrels of the water meter, which then indicates the measured flow of water.

The **MK** water meter comprises a body, metering unit, and counter mechanism. The inlet duct by which the water enters the body is vertical and the outlet duct for the water is horizontal. The flow of water passing through the water meter drives the propeller installed in the metering unit. The propeller is oriented vertically. The magnet in the wet section of the water meter is coupled to the counter magnet installed in the dry section of the water meter. A system of gears drives the pointers and barrels of the water meter, which then indicates the measured flow of water.

The **MH** water meter comprises a body, metering unit, and counter mechanism, and optionally, may feature a fire hydrant standpipe. The inlet duct by which the water enters the body is vertical and the outlet duct for the water is horizontal. The flow of water passing through the water meter drives the propeller installed in the metering unit. The propeller is oriented vertically. The magnet in the wet section of the water meter is coupled to the counter magnet installed in the dry section of the water meter. A system of gears drives the pointers and barrels of the water meter, which then indicates the measured flow of water.

The **MWN/JS** coupled water meter comprises a type MWN master water meter as specified above and a side water meter. The installed side water meter can be a type JS single-jet vane-wheel dry water meter. A spring-action switchover valve governs the flow path of the metered water, so that if the water flow is low the water is diverted to the side water meter and if the water flow is high the water is diverted to the master water meter. The spring-action switchover valve operates automatically and requires no external source of power. Operation of the spring-action switchover valve means that the measurement ranges of the master and side water meters overlap. In this way the coupled water meter has a wide measurement range, which starts from the minimum volumetric flow of the side water meter and completes with the maximum volumetric flow of the master water meter.

The **WI** irrigation water meter comprises the metering unit and the counter mechanism. The flow of water passing through the water meter drives the vane wheel installed in the metering unit. The vane wheel has the axis perpendicular to the body bore centreline and operates like an undershot water wheel. A worm and wheel transmission with a magnetic coupling allow the vane wheel to propel the set of gears for the counter mechanism in the dry section. The motion of the gears is translated into the meter's pointers and barrels, which then indicate the measured flow of water.

4. Selection of a water meter

The proper selection of the size criterion (for DN, the nominal diameter) of the water meters should always be based on the operating conditions, i.e. the mean and maximum operating volumetric flow of water.

A water meter that is too large not only increases the purchase costs, but also reduces the water measurement indication accuracy when the water flow is low.

A water meter that is too small overstresses the mechanism, resulting in premature wear of the moving components.

For your water meter to perform properly within its measurement range limits and maximum indication error limits, its operating range must be precisely determined, which can also be achieved based on monthly water demand, considering the minimum and maximum volumetric flow values (for existing installations, it is recommended to monitor the water supply).

It is recommended to choose a water meter size where the maximum foreseen volumetric flow of the system is equal to the following:

- 0,5 to 0,7 of permanent flow rate Q_3 for type **JS Impero** water meters,
- 0,5 to 0,7 of permanent flow rate Q_3 for type **MWN Nubis** water meters,
- 0,3 to 0,4 of permanent flow rate Q_3 for type **MWN130 Nubis** water meters,
- 0,6 to 0,8 of permanent flow rate Q_3 for type **MK** water meters,
- 0,6 to 0,8 of permanent flow rate Q_3 for type **MH** water meters,
- Q_3 for the coupled **MWN/JS** water meters.

The permanent flow rate Q_3 values for specific water meter types are listed in Table 3.

A correct selection of the water meter type shall be made with consideration of the following specifications/requirements:

- water temperature and chemical characteristics (e.g. presence of impurities),
- system pressure,
- maximum pressure loss allowed across the water meter,
- potential for sedimentation of substances from a water solution in the water meter,
- the installation space and shape of the piping available for the water meter and its connections,
- any remote indication relay & flow rate measurement required.

In addition to the foregoing, the water meter to be selected shall be such that frequent or prolonged flow rates are not within the operating range of the spring-action switchover valve. The switchover operating ranges are shown in the specific Technical Data Sheet.

5. Selection of a meter for irrigation water

The proper selection of the size criterion (for DN, the nominal diameter) of the irrigation water meters should always depend on the operating conditions, i.e. the mean and maximum operating volumetric flow of water in the pipe system to which the water meter is to be connected rather than the diameter of the pipe.

An irrigation water meter that is too large under actual operating conditions not only increases the purchase costs, but it also reduces the water measurement indication accuracy when the water flow is low.

An irrigation water meter that is too small overstresses the mechanism, resulting in premature wear of the moving components. For your irrigation water meter to perform properly within its measurement range and maximum indication error limits, its 24-hour operating range must be precisely determined, although this can also be achieved based on monthly water demand, considering the maximum volumetric flow values. The maximum permitted loads of the irrigation water meters are listed in Table 4.

Table 4. Maximum permitted loads for irrigation water meters.

Type (irrigation water meter size)	Maximum operating flow rate	Maximum monthly load limit
DN [mm]	[m ³ /h]	[m ³ /month]
40	25	10800
50	30	12960
65	50	21600
80	80	34400
100	125	54000
125	175	75600
150	250	108000
200	450	194000
250	70	302000

6. Delivery inspection

The measurement device as supplied by the manufacturer requires inspection to verify that no external shipping damage is present, especially on the body, the body flanged ends, the counter guard, and the wiring (if the version includes a transmitter module).

Verify that the tamper seals match the verification or security markings, that the seals are securely installed, and that the water meter part designation markings are present.

The following markings are affixed to the counter dial, the nameplate, or the body of each meter (for MWN400, MWN500 and WI meters, the markings may vary – consult Apator Powogaz S.A. for details):

- Manufacturer’s name/logo and full address details,
- MID type examination marking,
- Type trademark,
- Serial number,
- Production year,
- The metrological marking comprises the capital letter M and the two last digits of the production year in which the marking was applied to the measurement device,

- Direction of flow, shown with an arrow (on the body),
- The marking for horizontal piping, where H denotes that the water meter is installed in horizontal orientation and its counter pointing upward,
- The marking for horizontal and vertical piping, where V denotes that the water meter is installed in horizontal orientation and its counter pointing sideways,
- Volumetric flow value Q_3 (m³/h),
- Measurement unit designation, m³ (see the counter scale),
- Maximum pressure loss Δp ,
- For cold water meters: the maximum temperature limit, e.g.: T50 (50°C),
- For hot water meters: the maximum temperature limit, e.g.: T130 (130°C),
- Maximum pressure limit: MAP16 (PN16).

7. Water meter installation requirements

7.1. The installation location should provide easy access for the process of installation, removal, servicing, and reading, and be separated from rooms in use or for storage. The installation location should be sheltered from the weather, including sub-zero temperatures, high humidity levels, dust, and the effects of electrical power and gas systems. If there is no installation location suitable according to these criteria, the water meter can be installed in a dedicated chamber, but the installation location inside it must be sufficiently high above the chamber bottom. The chamber must have a sediment trap or a water drain discharging to the outside.

7.2. The water meter must not be exposed to shocks or vibration while installed due to nearby equipment or to excessively high ambient air temperatures, contaminants, flooding with water, or corrosive agents. The installation location temperature must be between +5°C and +55°C. Protect the water meter from hydraulic turbulence, including cavitation and water rams.

7.3. Provide stop valves upstream and downstream of the water meter connections to enable isolation from the water for removal or repair of the water meter. The stop valves must expose the entire water supply pipe bore.

7.4. If the water flow is expected to be contaminated during operation of the water meter, install a suitable filter or trap between a straight upstream section of the piping and the upstream stop valve.

7.5. To prevent the installation fastening from stressing the water meter body, it is recommended to use expansion (deflection) couplings installed on the meter's discharge side. The coupling must permit the reduction of the length by telescopic sliding of its sleeve.

7.6. The piping route geometry at the installation location must prevent air blocks from forming within the installation length of the water meter. The water meter must remain completely filled with water, so the water supply piping downstream of it must not have a drop in the downstream direction.

7.7. Prevent overstressing of the water meter due to the attached piping or other equipment. If necessary, install the water meter on a pedestal or a bracket. The upstream and downstream piping must be properly fastened so that no component of the system shifts by the action of water when the water meter is removed or detached on one of its ends.

7.8. The operating pressure at the inlet of the water meter's measurement chamber must be \leq the maximum allowed pressure (MAP) for which the water meter is rated. The minimum allowed pressure (MAP) at the water meter's outlet must be 30 kPa (0.3 bar).

7.9. The installation of the water meter in the system must conform to the intended operating orientation: horizontal or vertical, as applicable by specification (see Table 2).

7.10. According to the provisions of the EC Type-Examination Certificate, the MWN130-NC transducers may operate without taking into account straight pipe sections upstream (U0) and downstream (D0) of the transducer. For operating conditions in which disturbances in the flow profile occur upstream of the transducer, it is recommended to install the transducer in accordance with the guidelines specified in section 7.11.).

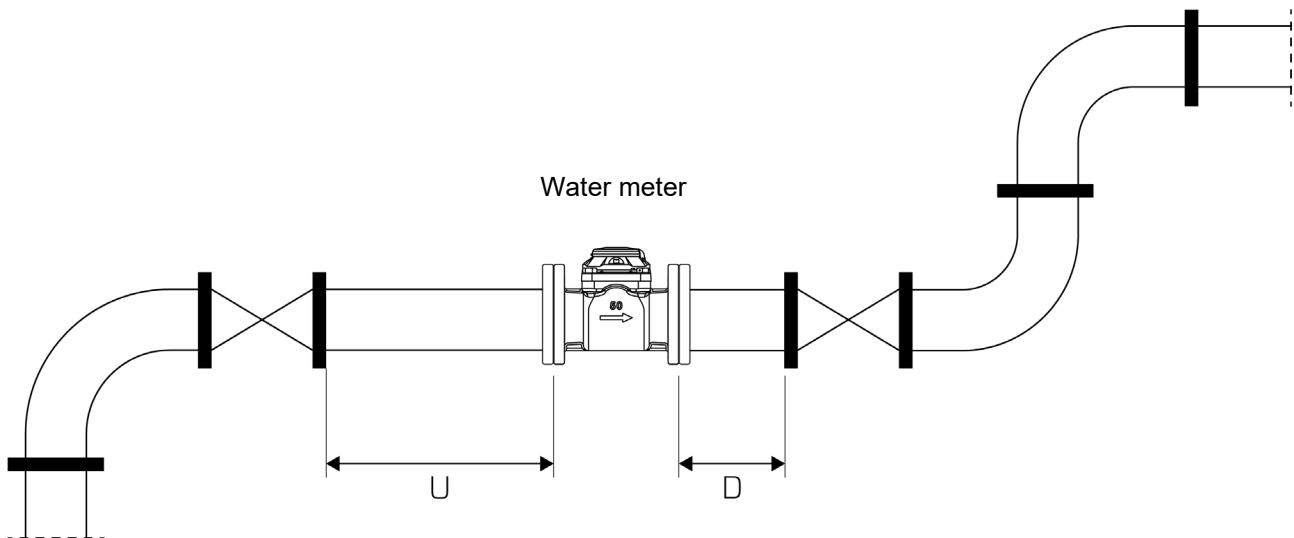

Fig. 2. Installation of the water meter.

7.11. Special installation requirements for the water meters:

- The piping can feature straight sections upstream and downstream for protection against the negative effects of water flow turbulence due to bends, valves, and other system components, the upstream side can use a straight piping section with a length of $U3 = 3 \times DN$ (nominal diameter of the water meter).
- If the water meter is to be installed downstream of a double bend, a check valve, a pump, or any other component which generates significant flow turbulence, double the specified upstream straight piping section length as follows: $U6 = 6 \times DN$, if the turbulence-generating component is a piston pump, triple the length: $U9 = 9 \times DN$. To avoid an upstream straight section this long, a flow vane can be installed upstream of the water meter. The turbulence forming downstream of the water meter is generally inconsequential to reading accuracy. However, if backflows occur then there is a risk of failure of the propeller/vane wheel bearings. It is recommended to counter this by installing (if feasible) a short straight section downstream of the water meter, and the section length must be: $D2 = 2 \times DN$.

CAUTION! Never attempt to weld a system in which a water meter is installed, as it this may cause a failure!

7.12. The upstream and downstream pipe sections must be concentric to one another. Install all seals concentric to the pipe bore centreline. It is not permitted to install the water meter offset (eccentrically) from

the pipe centreline, and especially to have the piping-to-water meter seals offset and obstructing the pipeline bore, as this may cause a flow turbulence.

7.13. The water flow through the water meter must be in the direction shown by the flow arrow affixed to both sides of the water meter body.

7.14. The water meters are intended for connection by flanged ends. The flanges are fabricated as per PNISO-7005-2 and PN10 in the standard version. Other fabrication reference standards are available on request. The system pipe connections with the water meter must have flanges with the same bolt hole pattern as the water meter flanges.

7.15. The water meters must be secured to the pipes with bolts and washers in a size compatible with the flange bolt holes.

7.16. Install the water meter with the data communication module attached near water supply systems (steel and/or copper piping, other water meters, RF transmission devices, etc.) and/or electrical wiring respecting the clearances specified below:

- 1 m or more from the nearest electrical power wiring,
- 12 cm or more from the nearest water supply systems.

Install the water meter with the data communication module attached in a part of the piping as far from all magnetization units and other permanent magnets, while using extra caution not to trigger a magnetic tampering alarm of the meter or its module.

8. Irrigation water meter installation requirements

8.1. The installation location should provide easy access for the processes of installation, removal, servicing and easy reading, as well as protecting the irrigation water meter from sub-zero temperatures.

8.2. Install stop valves upstream and downstream of the irrigation water meter connections to enable isolation from the water for removal of the water meter or its measuring insert for inspection or repairs.

8.3. The piping route geometry at the installation location must prevent air blocks from forming within the installation length of the irrigation water meter. The water meter must remain completely filled with water, so there must not be a drop in the downstream direction of the pipework.

8.4. For protection against the negative effects of water flow turbulence due to bends, valves, and other system components, the upstream side can have a straight section with a length of $U5 = 5 \times DN$ (nominal diameter of the irrigation water meter). If the flow meter is to be installed downstream of a double bend, a check valve, or a pump, double the specified upstream straight piping section length as follows: $U10 = 10 \times DN$, if the turbulence-generating component is a piston pump, triple the length: $U15 = 15 \times DN$. To avoid an upstream straight piping section this long, a flow vane can be installed upstream of the water meter. The downstream straight piping section length for the water meter must be: $D3 = 3 \times DN$.

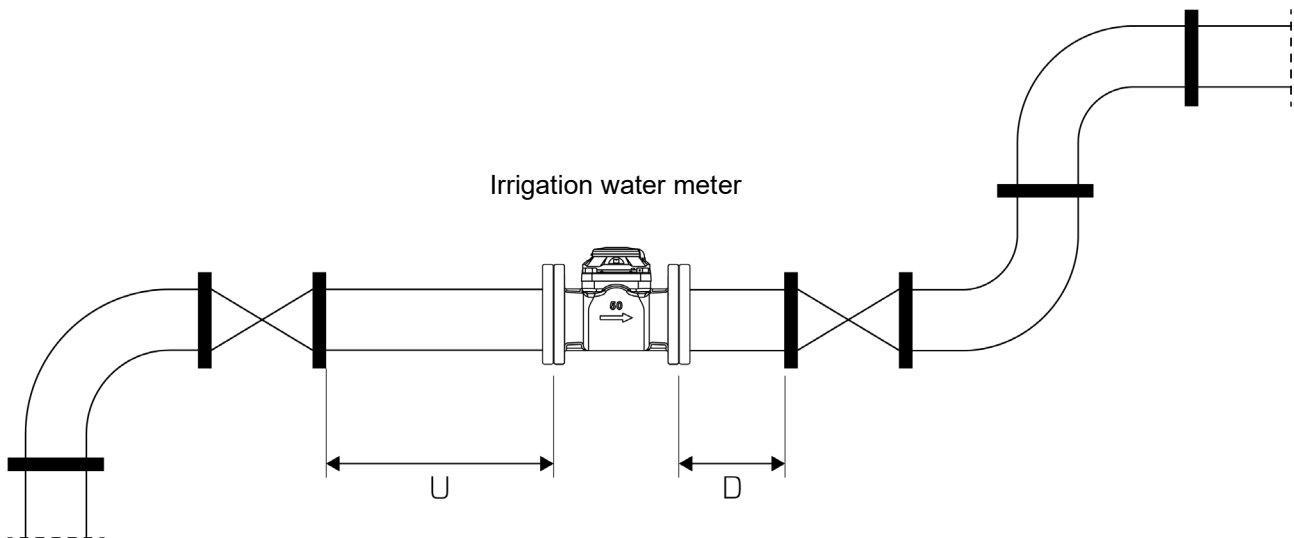

Fig. 3. Irrigation water meter installation.

8.5. All connections with the installed irrigation water meter must be in accordance with good practice. Install all seals concentric to the piping bore centreline. It is not permitted to install the water meter offset (eccentrically) from the pipe centreline, and especially to have the pipe-to-flow meter seals offset and obstructing the pipe bore, as this may cause turbulent flow.

8.6. The water flow through the irrigation water meter must be in the direction shown by the flow arrow affixed to both sides of the guard. The stop gate valves, if installed upstream and downstream of the irrigation water meter, must be fully open while the water is flowing.

8.7. When commissioning a new water supply system or repairing pipework before installation of an irrigation water meter, the pipework to be connected to the meter must be thoroughly flushed to remove all debris and contamination which could damage the water meter.

8.8. The irrigation water meters must be secured to the pipework with bolts and washers in a size compatible with the flange bolt holes..

8.9. Install the water meter with the RF module attached near water supply systems (steel and/or copper piping, other water meters, RF transmission devices, etc.) and/or electrical wiring respecting the clearances specified below:

- 1 m or more from the nearest electrical power wiring,
- 12 cm or more from the nearest water supply systems.

Install the water meter with the RF module attached in a part of the piping as far from all magnetization units and other permanent magnets while using extra caution not to trigger a magnetic tampering alarm of the meter or its module.

9. Priming with water, commissioning, and operation of the water meter / irrigation water meter

9.1. Before installing a water meter in the piping, flush the piping to remove all debris and contamination. If a filter is to be used, it must be cleaned before the installation process. For the flushing process, the water meter must be replaced with a straight pipe spool.

9.2. Prior to its installation, perform a functional test of the water meter: spin the propeller/vane wheel and check it for the correct direction of rotation. Verify the condition of the tamper seals.

9.3. With the water meter installed in the piping, open the water flow starting at a small rate with all vents open so that the air bled from the system does not cause the propeller/vane wheel to overspeed, which may result in bearing failure during a dry run.

9.4. During operation, the stop valves upstream and downstream of the water meter must be fully open.

9.5. Having completed the commissioning tasks, verify that the measurement device is operational: its reading should increase as the water flow increases. Specifically inspect that **the measurement device and/or its connections do not leak water**.

9.6. During operation of the measurement device periodically verify that the actual operating conditions are within the limits of intended use, especially the limits of pressure, temperature, and flow rate, **and that the measurement device and/or its connections do not leak water**.

10. Storage and transport

The brand-new or removed existing water meters shall be kept with the counter upwards or to the side, indoors, away from corrosive vapours, odours, and other agents which might be detrimental to the meter. Keep the storage room temperature between 5°C and 55°C. Protect the water meter in storage and during transport from vibration and shock which may damage the enclosure or internal components. Transport the meter in closed-body vehicles, in its original packaging or its substitute, whichever fully protects the meter from damage. If transported in low-temperature weather conditions, it is best to keep the product dry.

11. Troubleshooting

If the counter fails to indicate despite the water flowing through the water meter, check that the propeller/vane wheel is not jammed by dirt. If the meter fails to operate, even if clean and unclogged, or whenever other damage is evident, return the meter for repairs with an appended claim for the discovered defects. If the pulse transmitter module fails, report this to the manufacturer. If the troubleshooting is ineffective despite any instructions received from the manufacturer, return the meter for repairs.

12. Safety and environmental requirements

12.1. The water meter is a measuring instrument which is safe to use, provided it is installed properly and operated according to this installation and operating instructions.

12.2. Hazards exist during installation, servicing and operation of the product:

- a) Mechanical hazards (applicable to water meters):
 - Fall during improper handling
 - Water leaks, leading to flooding of the product due to improper installation or a water pressure exceeding the rated MAP
- b) Thermal hazards (applicable to water meters):
 - Burns from touching the water meter while it is in operation or a leak of hot water.

12.3. The mechanical hazards are reduced by the external shape of the measuring device, which facilitates handling. Large devices have fixtures for attachment to lifting equipment. The thermal hazards can be prevented by application of dedicated guards.

12.4. The installation and servicing of the water meter requires a suitable location with firm ground that will not cause a hazard of falling.

12.5. The water meter components are not harmful to human health or the environment. All measurement devices are delivered with hygiene certificates indicating their suitability for use with drinking water.

12.6. The applied ingress protection rating of the counters (which can be IP65 or IP68) and other design solutions protect the water meter against the negative effects of water vapour condensation interfering with the correct reading and operation of transmitter/data modules.

12.7. Classification of environmental conditions:

- OIML D 11:2013 (E) **mechanical class M1** (This class applies to locations with low vibrations and shocks)
- EN ISO 4064:2017 (E) **climate class B** (for stationary meters installed in buildings, within an ambient temperature range of 5°C to 55°C).

13. Pulse output value and installation diagrams for water metres / irrigation water meters

13.1. Standard water meter version pulse value for the NK transmitter module.

Nominal diameter (mm)	Cold water	Hot water
	Pulse value (dm ³ /imp)	Pulse value (dm ³ /imp)
40; 50; 65; 80; 100; 125	100	100
150; 200; 250; 300	1000	1000

13.2. Standard water meter version pulse value for the NO transmitter module.

Nominal diameter (mm)	Pulse value (dm ³ /imp)
40; 50; 65; 80; 100; 125	1
150; 200; 250	10
300	105,2632

13.3. Irrigation water meter pulse value for the NK transmitter module.

Nominal diameter (mm)	Pulse value (dm ³ /imp)
40; 50; 65; 80; 100; 125 150; 200; 250; 250	1000

13.4. Remote communication methods diagram.

Remote communication diagrams applicable to water meters manufactured by Apator Powogaz S.A. are available for most units and systems in downloadable files from: <https://www.apator.com/en/our-solutions/water-and-heat>

13.5. Transmitter cable extension.

To extend the standard cable of the transmitter module, use a shielded cable with the single core minimum size of 0.75 mm² and a total extension line impedance not higher than 500 Ω. Note that the transmission cable extension line must not intersect the existing power and data lines.

Note: Make the extension line as short as possible.

13.6. Example overview of the counter in an industrial flanged water meter, version NKOP (IP65), with the NK and NO transmitter modules installed.

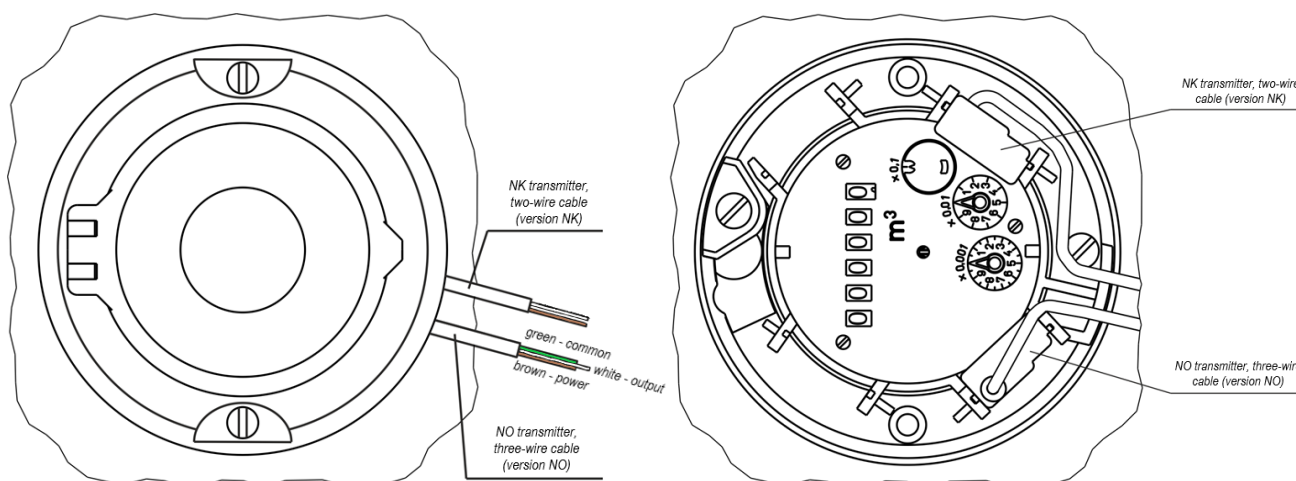

View of the counter with the guard and the IP65 flap shield (for cold water operation)

View of the counter with an example pulse output configuration and the IP65 guard assembly removed (for cold water operation)

See the detailed installation of the NK and NO transmitters on industrial water meters and the NK transmitter on irrigation water meters on <https://www.apator.com/en/our-solutions/water-and-heat> – go to the measurement device product page of interest and see the Download column.

14. Disposal of waste products and packaging

Hand over waste packaging to a segregated waste collection facility or dispose of it in compliance with waste segregation requirements, into a dedicated waste paper bin. If the packaging features plastic film parts, dispose of them in compliance with applicable household waste segregation requirements. If damaged or past its verification end, remove the product from the system and have it re-verified or recycled with the component materials recovered.



The product to be disposed of must be handed over to dedicated waste equipment dismantling processors for a stripdown and recycling process in compliance with the applicable national laws and regulations of the country in which the product has entered the market. Do not dispose of waste equipment into mixed household waste bins.

15. Your feedback

The instructions for our products are subject to continuous updating. Your suggestions for improvement are most welcome and will help us to optimise the instructions according to your needs. Please communicate all your feedback about this instruction to the manufacturer by e-mail at: support.powogaz@apator.com

The information presented in this manual is valid as of the date of its publication. The manufacturer reserves the right to make changes and improvements to the products without prior notice. This publication is for informational purposes only and does not constitute an offer within the meaning of civil law.



Apator Powogaz S.A.

Jaryszki 1c, 62-023 Żerniki, Poland

Office: sekretariat.powogaz@apator.com, tel. +48 61 84 18 101

Sales / Customer Service: tel.: +48 61 84 18 149

Customer Service Centre Support: handel.powogaz@apator.com

Exports: export.powogaz@apator.com

Technical Support: support.powogaz@apator.com, tel. +48 61 8418 131, 134, 294

Warranty Claims: reklamacje.powogaz@apator.com

www.apator.com

2026.034.I.EN

