

Operating instructions

Universal induction module IN-PULSE



ISO 9001

PN-N-18001

ISO 14001

Table of contents

Table of contents	2
1. Application.....	4
2. Device description	5
3. Basic components of the IN-PULSE module for installation on IP65/IP68 water meters, ...	6
4. Technical specifications	7
4.1 Dimensions of the pulse module and the water meter set (IP65) with clip-on module	8
5. Installation of the universal pulse module on water meters from APATOR POWOGAZ ...	10
5.1 Installation prerequisites.....	10
5.2 Installation on apartment water meters: JS Smart+; JS Smart C+ and JS Smart D+(DN15 or DN20; T50 or T90) in the IP65/IP68 version	12
5.2.1 Positioning and fixing the intermediate ring on the counter assembly and checking the installation correctness	12
5.2.2 Installation of the pulse module	17
5.3 Installation on a house water meter, type JS Master+, JS Master C+ and JS Master D+(DN25÷DN40; T50 or T130) in the IP65 version.....	19
5.3.1 Alignment and fastening the locating interface ring on the counter guard and proper fitment verification	19
5.3.2 Installation of the pulse module	21
5.4 Installation on a house water meter, type JS Master (DN25÷DN40; T50) in IP68 version.	24
5.5 Installation on industrial water meter type MWN (T50; T130), JS(T50), MK(T50), MH(T50); in IP65 version	27
5.5.1 Fastening the intermediate ring on the counter guard.....	27
5.5.2 Installation of the pulse module	27
5.6 Installation on industrial water meters type MWN (T50), JS (T50), MK (T50), MH (T50) in IP68 version	30
6. Operation	33
6.1 Communicating with the module.....	33
6.2 Recording and reading data by a pulse converter.....	33
6.3 RTC (real time clock).....	34
6.4 Warehouse mode	34
7. Device configuration	34
7.1 Automatic calibration of the counter mechanism.....	36
7.2 Indicator revolution weight.....	36

7.3 Alarms, events, event thresholds.....	36
8. Regulatory and standards compliance	37
9. Removal	38
10. Operating precautions	41
11. Warranty terms and conditions.....	41
12. Environmental protection	41
Revision history	41

1. Application

The IN-PULSE module is a universal pulse module used for remote reading of water meter indicators from Apator Powogaz S.A. This device counts the rotations of a dedicated water meter indicator and then transmits the data to subsequent devices using pulse outputs. Revolutions are detected by an induction scanning module.

Table 1 Product compatibility chart

Type and name of water meter / flow meter	Q ₃ [m ³ /h] or DN[mm]	Indicator rotation weight of the induction pointer [dm ³ /revolution]	Temperature class
JS Smart D+	Q ₃ 1.6÷4	1	T50 / T90
JS Smart C+	Q ₃ 1.6÷4	1	T50 / T90
JS Smart +	Q ₃ 1.6÷4	1	T50 / T90
JS Master D+	Q ₃ 6.3÷16	1	T50
JS Master C+	Q ₃ 6.3÷16	1	T50
JS Master +	Q ₃ 6.3÷16	1	T50 / T130
JS Impero	Q ₃ 50÷100	10	T50
MWN Nubis	DN 40 ÷ 125	10	T50 / T130
MWN Nubis	DN 150 ÷ 400	100	T50
MWN Nubis	DN 150 ÷ 300	100	T130
MK	DN 50 ÷ 100	10	T50
MK	DN 150	100	T50
WI	DN 40 ÷ 250	100	T30/T50
MH	DN 50 ÷ 65	10	T30/T50

2. Device description

The IN-PULSE Universal Impulse Adapter (Fig. 1) is a battery-operated electronic device that has been designed as part of an Automatic Meter Reading (AMR) system primarily intended for water utilities and other users of wired data transmission.

The element that ensures communication is the pulse module, which consists of electronic components and a battery. Thanks to the induction interface for reading the water meter's data and the high IP68 protection class casing, the device is designed to operate under harsh environmental conditions, including high humidity.

Additionally, the device is equipped with a Near Field Communication (NFC) interface that is compatible with ISO 15693 and ISO 18000-3 mode 1. The fixing element for attaching the cover on a water meter with an IP65 protection rating is an intermediate positioning ring that allows its correct installation in the required position (details later in the manual). The cover on a water meter with an IP68 protection rating is mounted on the attachments of the counter guard.

The device scans the dedicated water meter counter indicator using an induction system, which detects and recognizes the directions of its rotation. This solution enables remote transmission of the actual reading of the water meter counter and information about events occurring at measurement points, using pulse outputs, thus allowing for extensive data analysis and performance diagnostics.

The working time and configuration were selected so that the device would operate over two water meter calibration periods.

The device comes with the following communication interfaces:

- indicator revolution inductive sensor;
- local communication interface – NFC;
- magnetic field sensor.

Basic device functionalities:

- water meter readout recording (forward and back water flow);
- event detection and alerting;

Events detected and recorded by the device:

- Backflow (per preset thresholds),
- Low battery,
- Magnetic field detection,
- Device disconnected (the module detected is removed from the water meter),
- Maximum overtemperature (> 60°C)
- Minimum undertemperature (< -15°C).

3. Basic components of the IN-PULSE module for installation on IP65/IP68 water meters,

- Pulse module – main device module responsible for communication,
- Retaining ring facilitating correct positioning and installation of the module on various types of IP65 water meters manufactured by Apator Powogaz. The IP68 water meter version does not use the ring, as its role is fulfilled by a special counter guard with a #UTIP (Universal TI Plug) connector,
- Cover – protection cover for water meter counter,
- Ring lock – stud permanently fixing the module to the counter guard.

Induction clip-on module **IN-PULSE**

in the IP68 protection class for installation on the counter of Apator Powogaz water meters, which are available in two IP protection classes:

IP65

IP68



Accessories

Induction modules in each set come equipped with the accessories listed below, enabling installation on the IP65/IP68 water meter:

IP65

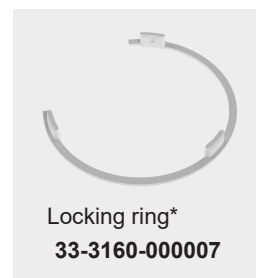
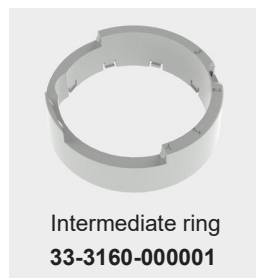
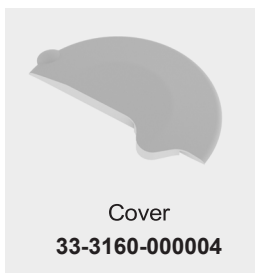

*The locking ring (33-3160-000007) is used in apartment water meter assemblies (excluding JS Smart D+) and JS Master +/C+/D+ house water meter assemblies.

IP68

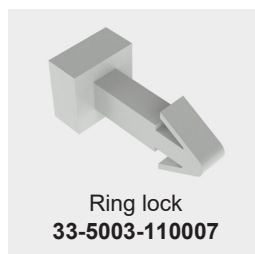

4. Technical specifications

Clip-on module	IN-PULSE
Installation method	Direct installation of the IP68 version on a water meter with the #UTIP (Universal TI Plug) connector (lock protecting against unauthorised clip-on module removal) or with an intermediate IP65 ring
Pulse counting method	Induction resonance module
Power supply	3.6 V A lithium battery
Battery life	12 years for the temperature profile 10% of operating time at 10°C 80% of operating time at 20°C 10% of operating time at 30°C
Performance temperature limits	-15°C to 60°C
Connection cable	5-wire, length: 3 m
Types of pulse outputs	NPN OD (open-drain)
Pulse outputs	2
Pulse width	65 ms
Contact make resistance	70 Ω max.
Short-circuit current	100 mA max.
Maximum voltage	30 V
Degree of protection	IP68
Dimensions	130 x 73 x 42.7 mm
Conformance to standards:	See the "CE Declaration" Annex.
Weight	0.106 kg

4.1 Dimensions of the pulse module and the water meter set (IP65) with clip-on module

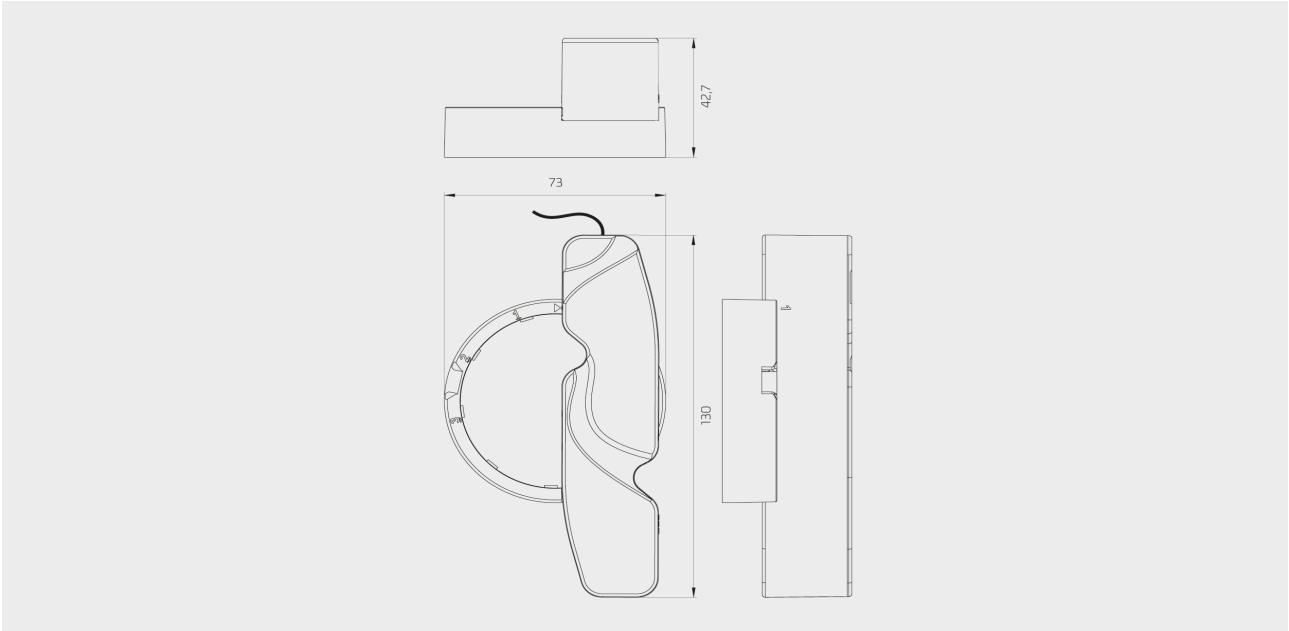

Fig. 1. Overall pulse module dimensions with intermediate ring for water meters in IP65 version.

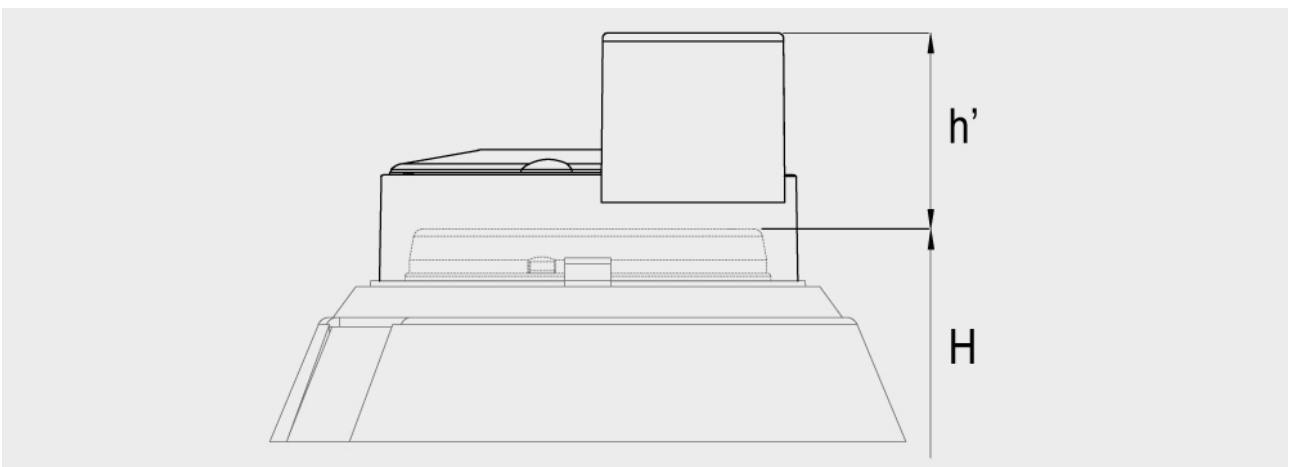

Fig. 2. Water meter height with the IP65 module installed.

Water meter types	Water meter + module height H + h' [mm]
Apartment meters: JS / (T50 or T90); DN15 or DN20	H* + 32.2
House meters: JS / (T50 or T130); DN25 ÷ DN40	H* + 35,0
Industrial meters: MWN (T50 or T130), JS, MK (T50), MH (50); (DN per assigned sizes)	H* + 34.8

*The H values are specified in the product data sheets available at www.apator.com

5. Installation of the universal pulse module on water meters from APATOR POWOGAZ

5.1 Installation prerequisites

Each water meter compatible with the IN-PULSE universal pulse clip-on module features a dedicated induction indicator (“Ti” or “Ti/IR”).

For IP68 water meters, there is a single Ti/IR or Ti indicator on the counter dial.

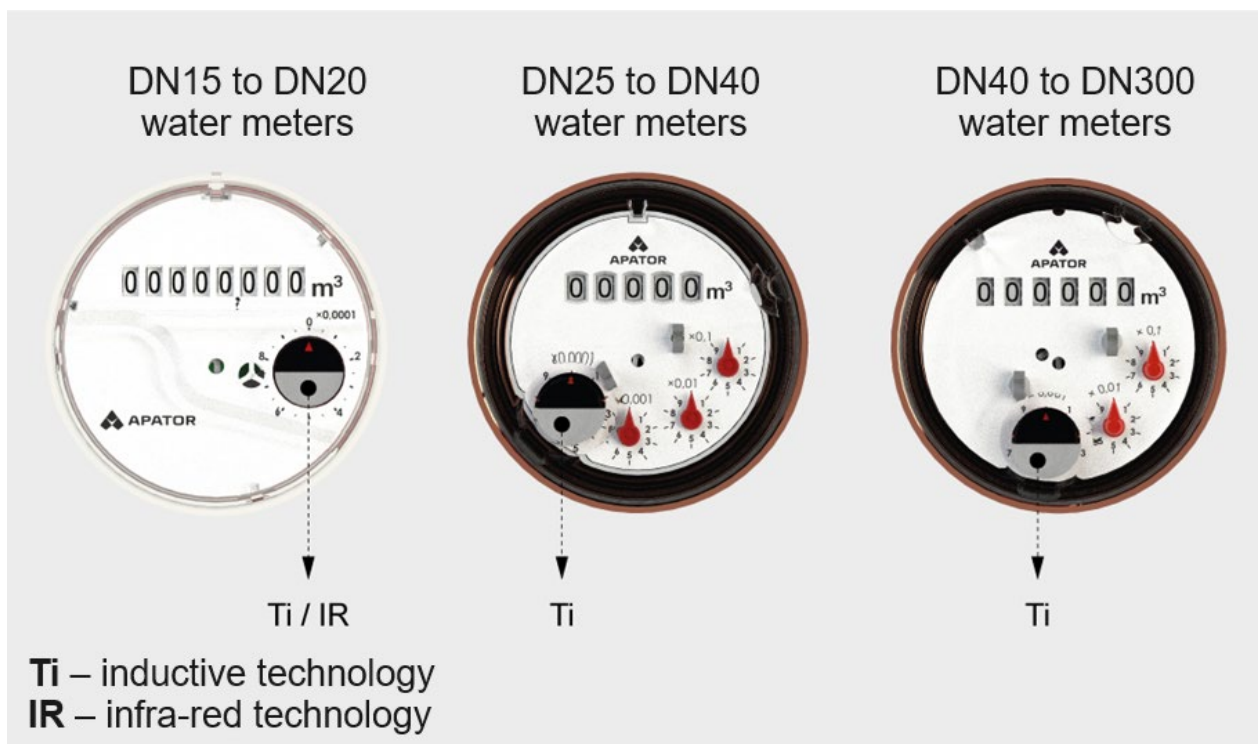

Fig. 3. Compatible data transmission technologies and reading indicator locations.

However, for IP65 water meters, there are two independent single Ti/IR or Ti indicators. Water meter indications can still be read with the existing overlays (RF modules, pulse modules and M-Bus modules) which support an optical IR interface.

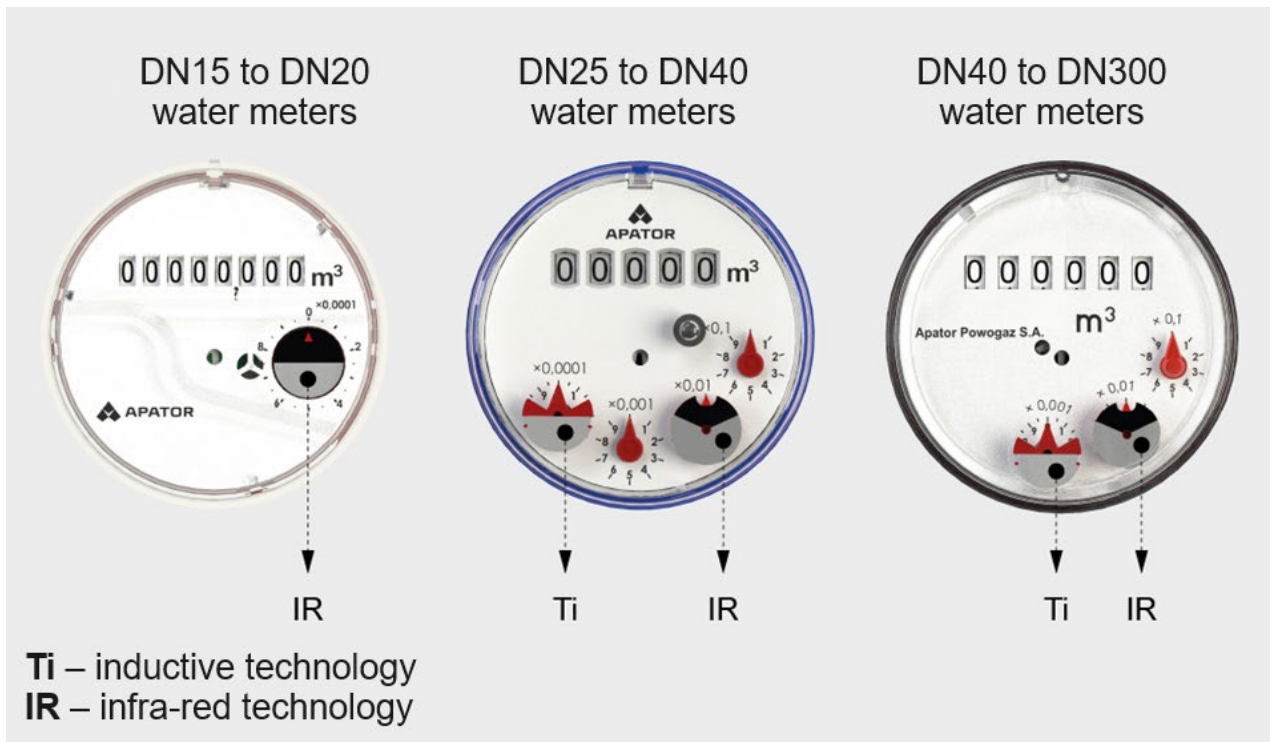

Fig. 4. Compatible data transmission technologies and reading indicator locations.

Prepare the water meter for the installation:

- Remove the safety cover from the water meter (if installed).
- Clean the top of the counter mechanism guard (clean the ring recess thoroughly) and the pulse module base which is placed directly over the induction indicator.

Remark: Do not use any chemicals, including solvents. Use regular detergents thinned with water.

No warehouse mode supported – the module is provided pre-programmed and pre-configured (with a specified type of pulse output and pulse weight); ready for immediate use.

5.2 Installation on apartment water meters: JS Smart+; JS Smart C+ and JS Smart D+(DN15 or DN20; T50 or T90) in the IP65/IP68 version

5.2.1 Positioning and fixing the intermediate ring on the counter assembly and checking the installation correctness

1. Position the intermediate ring at the counter guard as shown in the figure below to determine which intermediate ring snaps correspond with the grooves on the water meter glass panel.

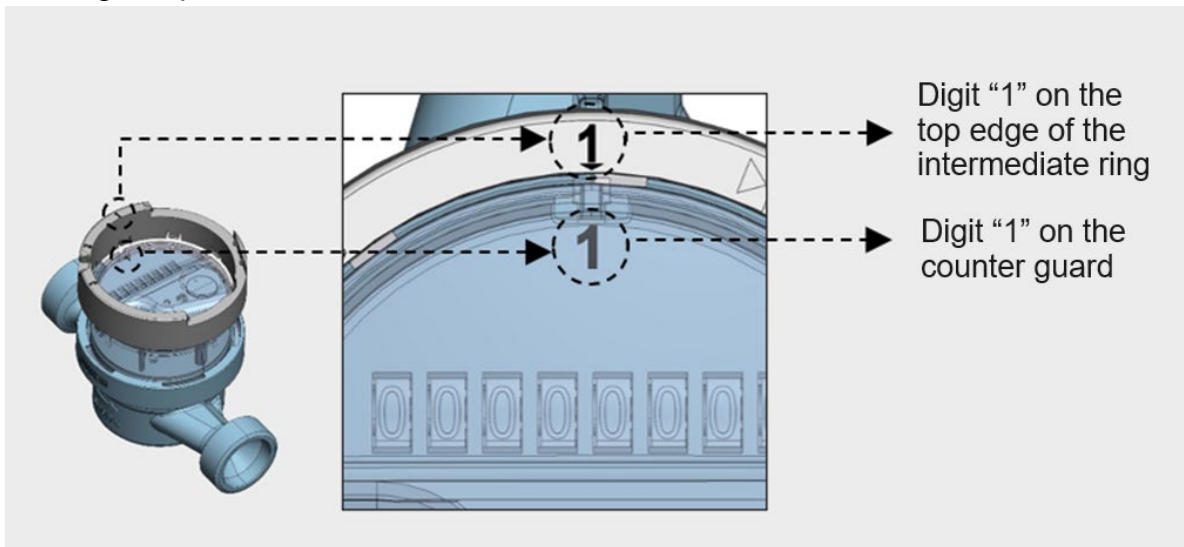

Fig. 5. Correct positioning of the intermediate ring in relation to the counter glass panel.

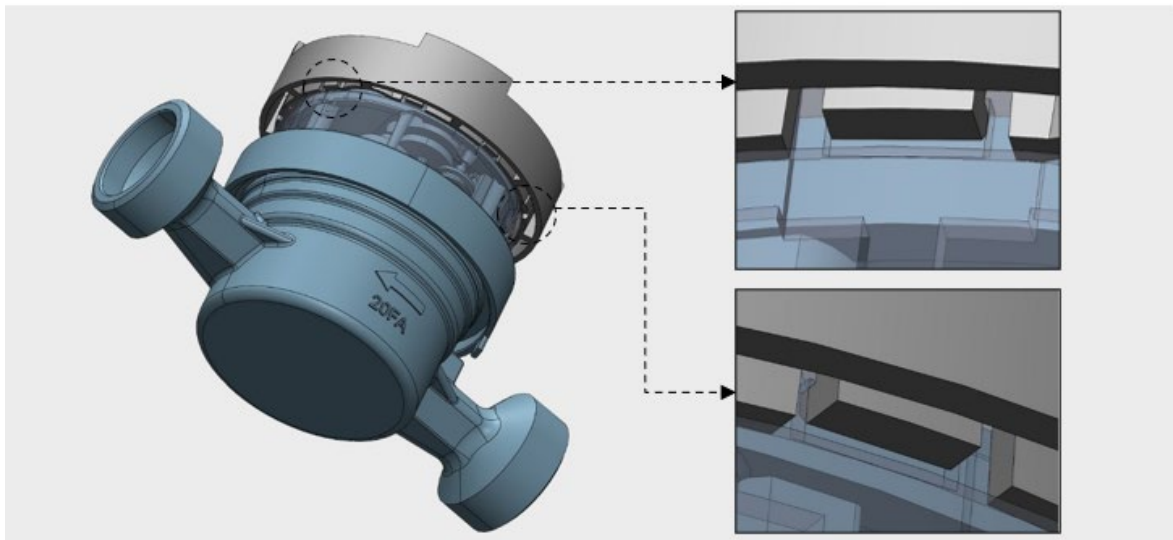

Fig. 6. Two out of three working snaps of the intermediate ring, these are the locations where the locking ring protrusions must be entered.

2. Mounting the locking ring* on the intermediate ring.

When mounting the locking ring on the intermediate ring, the locking ring must be positioned so that its visible protrusions enter the intermediate ring recesses with snaps fixing the ring in corresponding sockets on the JS Smart water meter counter cover – see Fig. 6.

Attention! *The locking ring (33-3160-00007) is used in apartment water meter assemblies (excluding JS Smart D+).

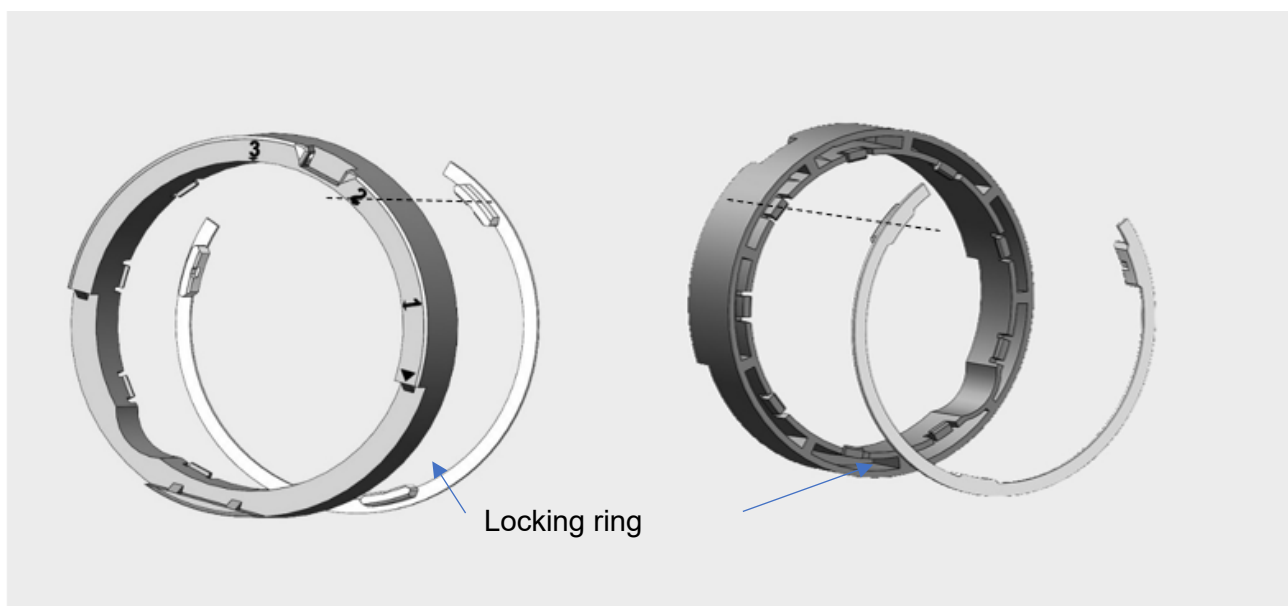

Fig. 7. Positioning the locking ring in relation to the intermediate ring

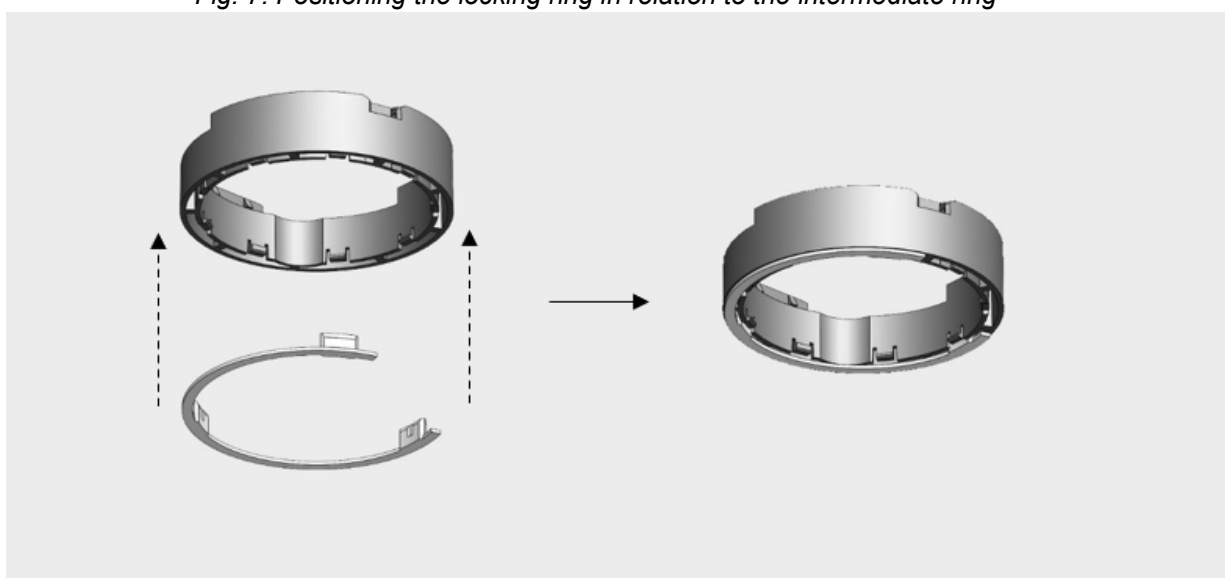

Fig. 8. Mounting the locking ring on the intermediate ring

2. Installation of the pre-assembled intermediate ring + locking ring set on the counter guard should start by positioning the digit "1" on the intermediate ring in relation to the digit "1" on the counter guard, as shown in Fig. 9.

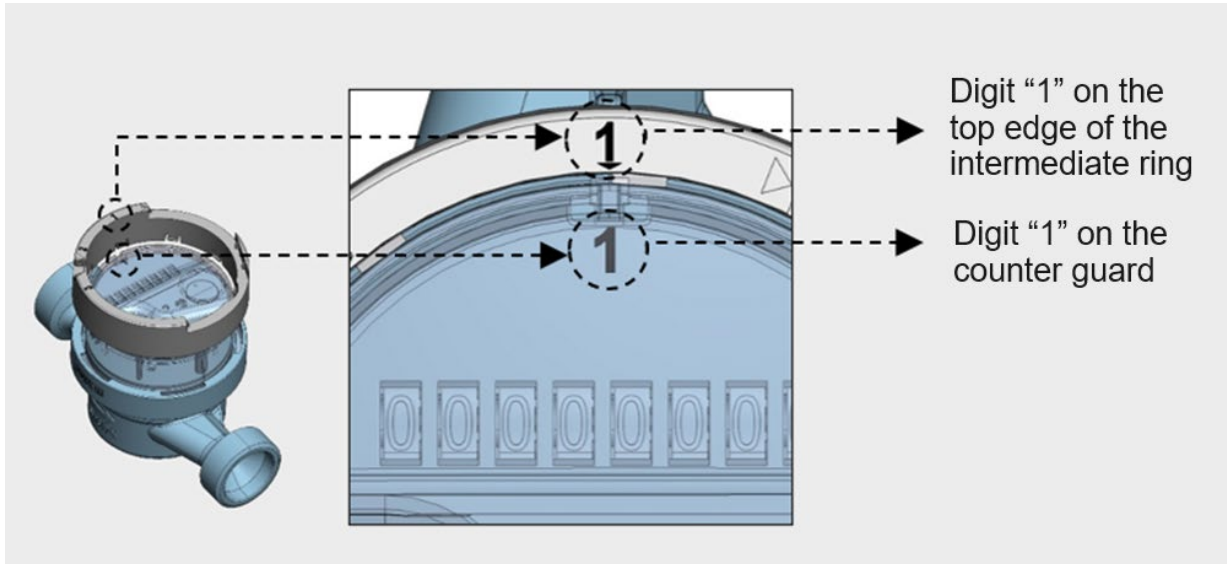

Fig. 9. Positioning the intermediate ring on the counter guard

4. While performing the actions described in section 3, adjust the position of the intermediate ring attachments in relation to the arrangement of snap-on detents on the cylindrical part of the water meter counter guard.

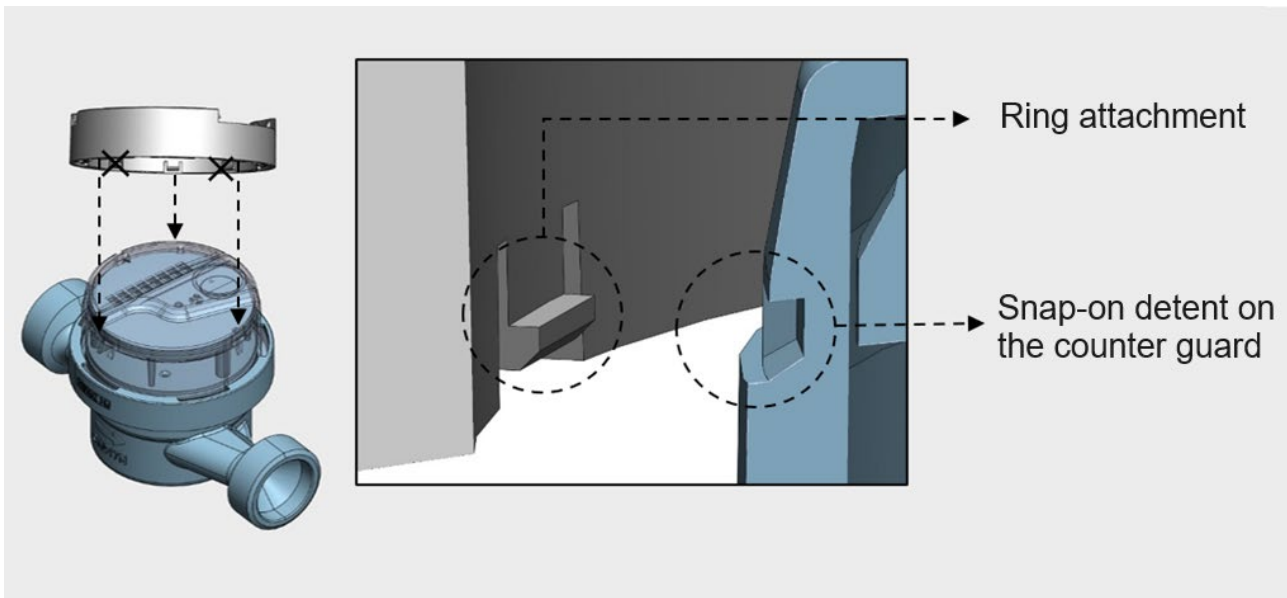

Fig. 10. Intermediate ring attachments matching the recesses on the cylindrical part of the water meter counter.

5. After completing the activities described in section 2 and 3, use both hands to press down the intermediate ring firmly on the counter guard until a “click” is heard.

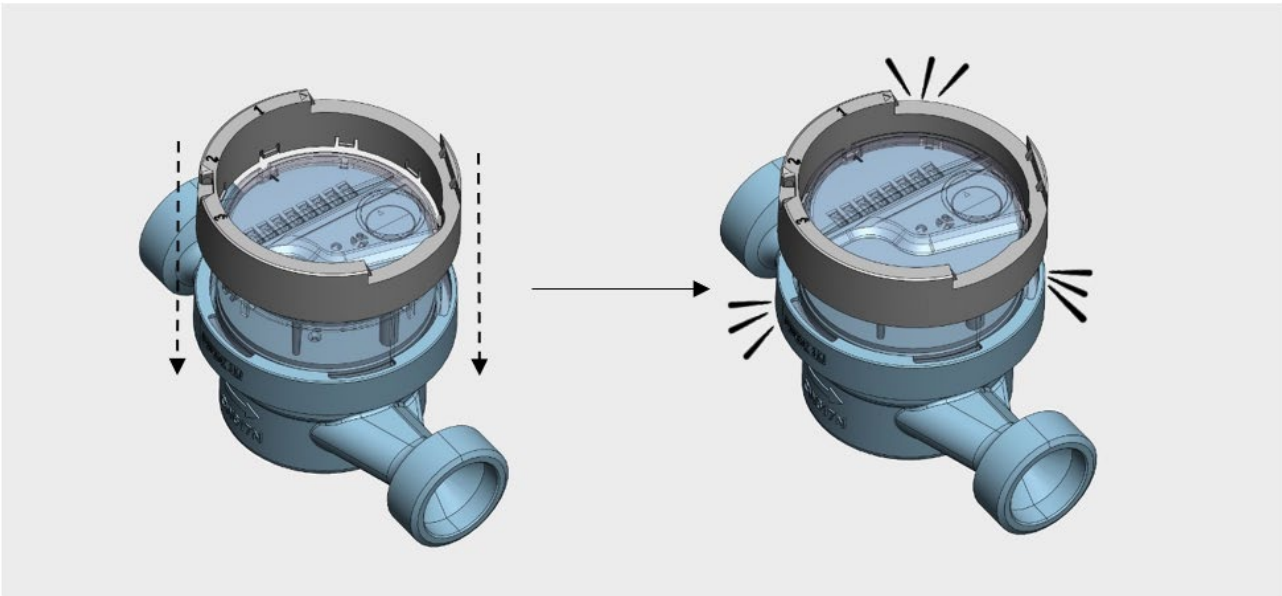

Fig. 11. Pressing the intermediate ring to the cylindrical part of the water meter counter

6. Check the correctness of the intermediate ring's mounting by attempting to remove it without using force.

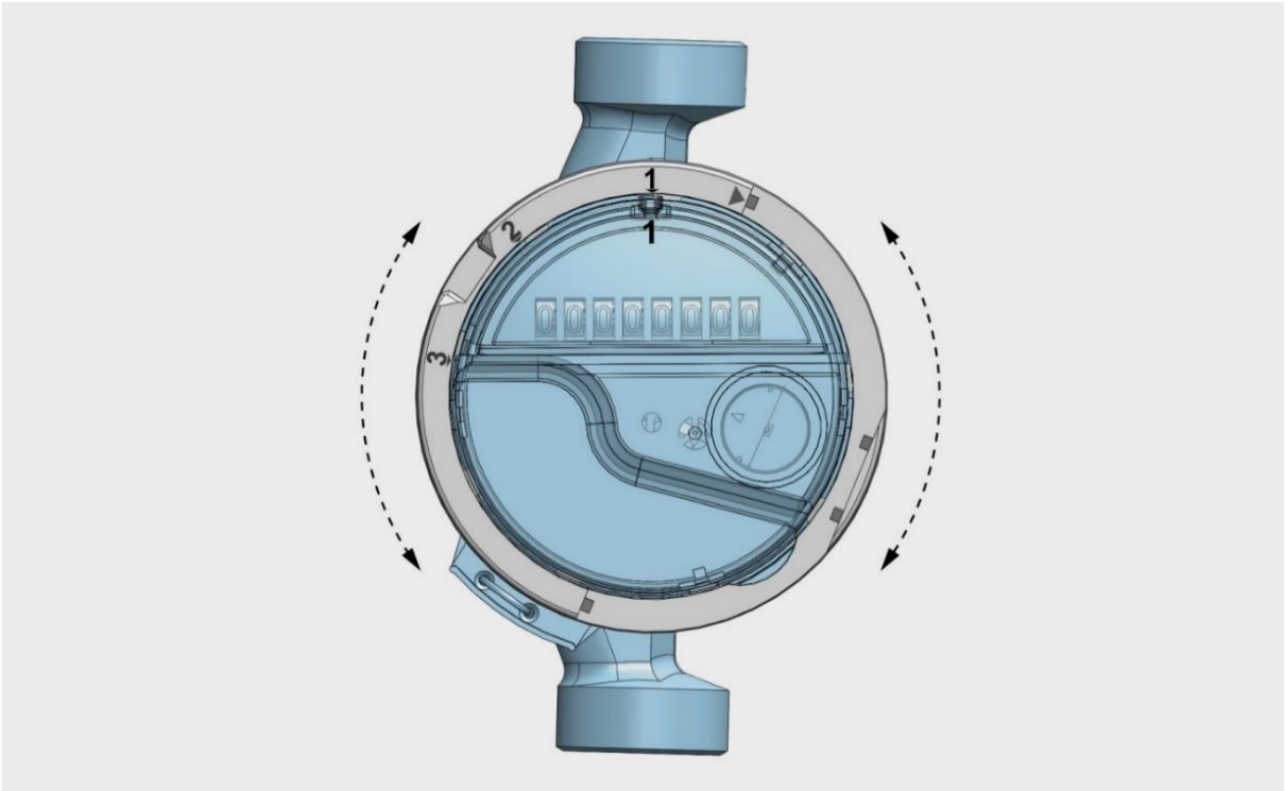

Fig. 12. Attempt to remove the intermediate ring from the cylindrical part of the water meter counter without using force.

5.2.2 Installation of the pulse module

1. Position the pulse module over the intermediate ring secured on the counter guard. Align the mark “1” on the pulse module side with the mark “Δ” on the top edge of the intermediate ring.

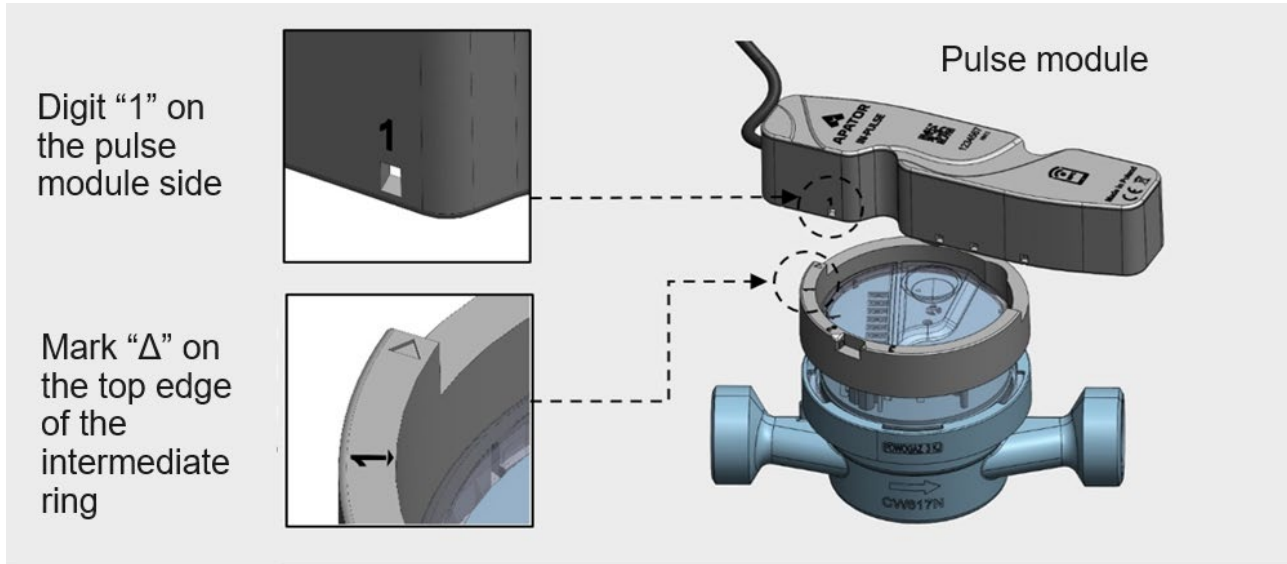

Fig. 13. Installation of the IN-PULSE inductive transmission module on the JS Smart water meter mechanism.

2. Insert one side of the pulse module inside the groove within the intermediate ring to engage the two snap-on detents of the pulse module over the two respective snap tabs on the intermediate ring (A).

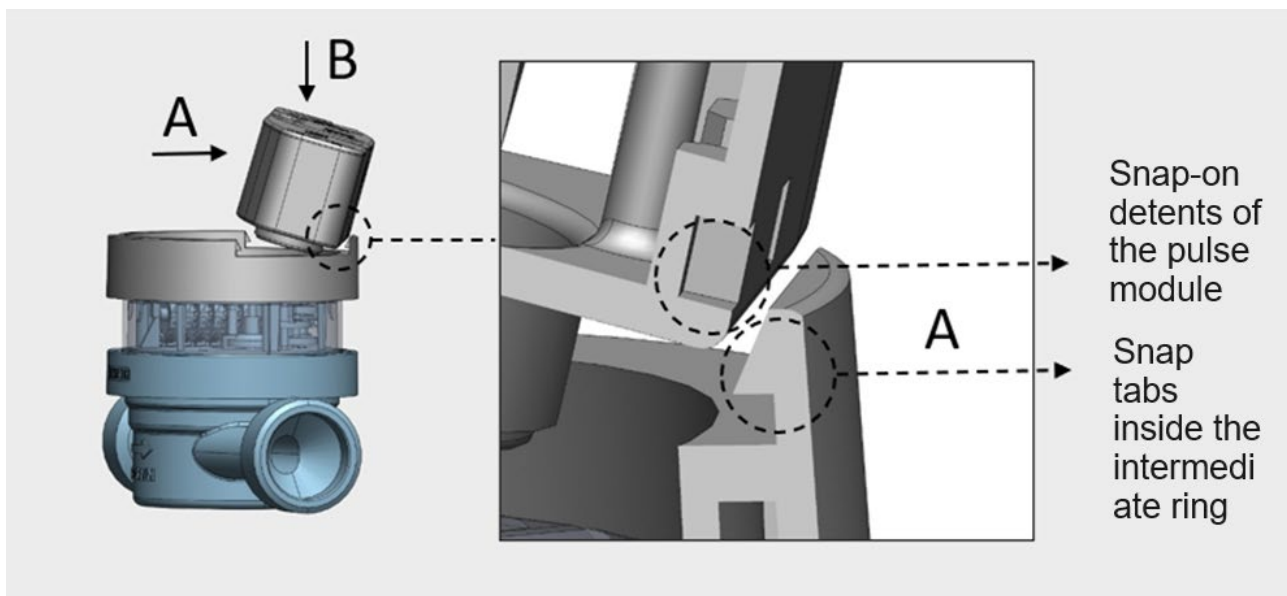

Fig. 14. Latching the IN-PULSE induction module on the intermediate ring.

3. Use both hands to firmly press down the opposite side of the pulse module into the intermediate ring and engage the two remaining snap-on detents (**B**) over the two respective snap tabs with a loud click.
4. Check the correctness of the pulse module's mounting by attempting to remove it without using force.
5. This completes the installation process.

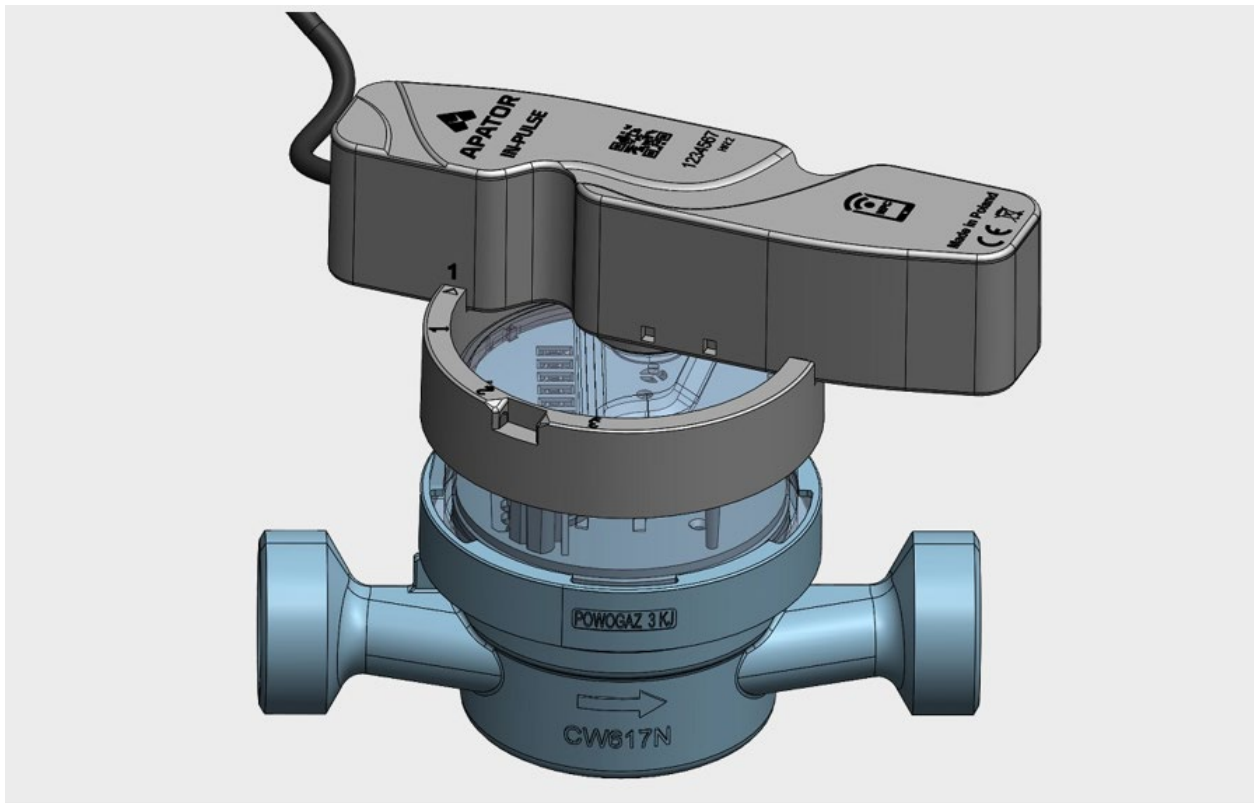

Fig. 15. IN-PULSE induction module correctly installed on an DN15 JS Smart water meter.

The pulse module will operate properly if installed according to the sequence explained above. The separable fastening of the pulse module and the intermediate ring allows easy replacement of individual components of the measuring point as required.

5.3 Installation on a house water meter, type JS Master+, JS Master C+ and JS Master D+(DN25÷DN40; T50 or T130) in the IP65 version

Generally, the IN-PULSE clip-on module for JS Master series water meters is installed in the same way as for JS smart series water meters, as described in section 5.2. However, the differences in the installation procedure for the intermediate ring + locking ring assembly are described in the following section.

5.3.1 Alignment and fastening the locating interface ring on the counter guard and proper fitment verification

1. Mount the intermediate ring on the water meter counter guard so that the digit “3” on the top edge of the mounting ring is located directly over the “3” mark on the water meter counter guard.

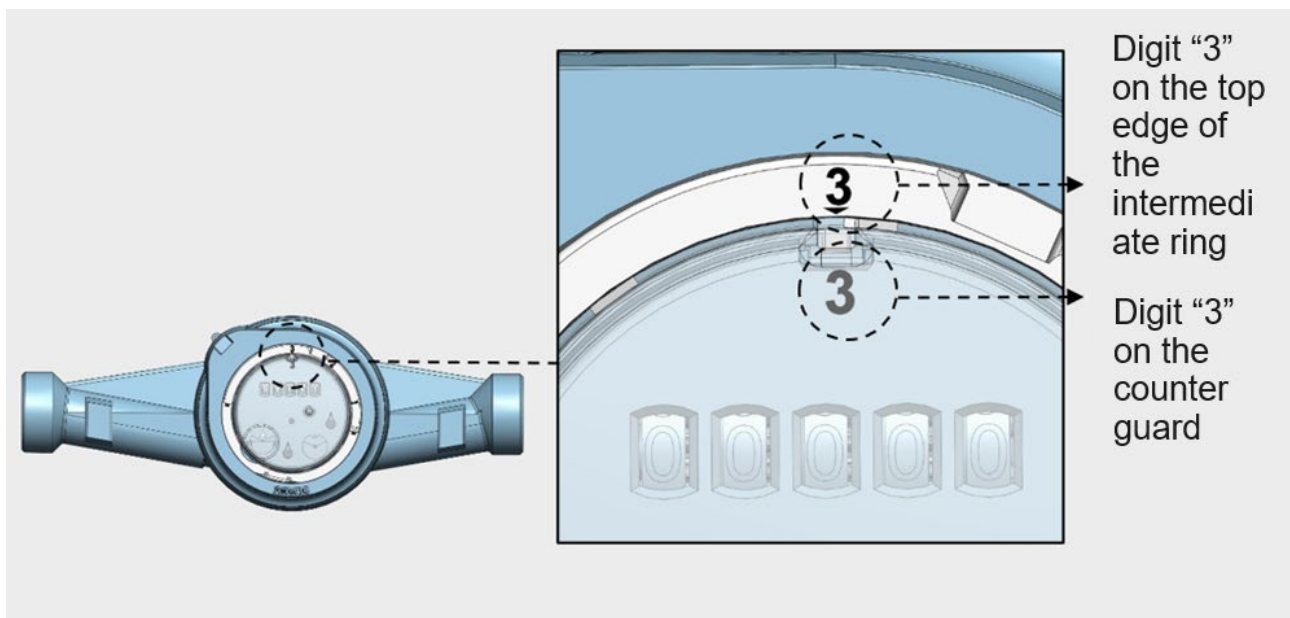

Fig. 16. Intermediate ring installation on the JS Master water meter counter guard.

2. Mounting the locking ring on the intermediate ring.

Install the locking ring on the intermediate ring in line with the method specified in Figures 17 and 18 (below). Particular attention should be paid to positioning the locking ring in such a way that its protrusions are placed in those intermediate ring recesses in which there are snaps fixing the ring in corresponding sockets on the JS Master water meter counter cover, which is visible when placing the clip-on module at the counter guard – see Fig. 17.

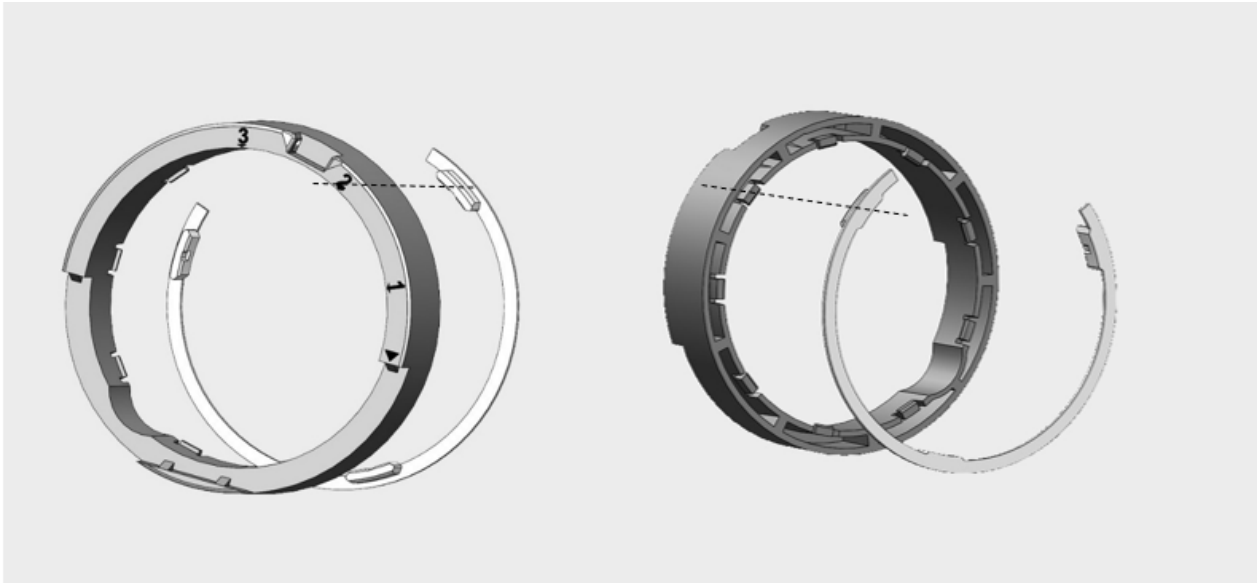

Fig. 17. Positioning the locking ring before intermediate ring installation.

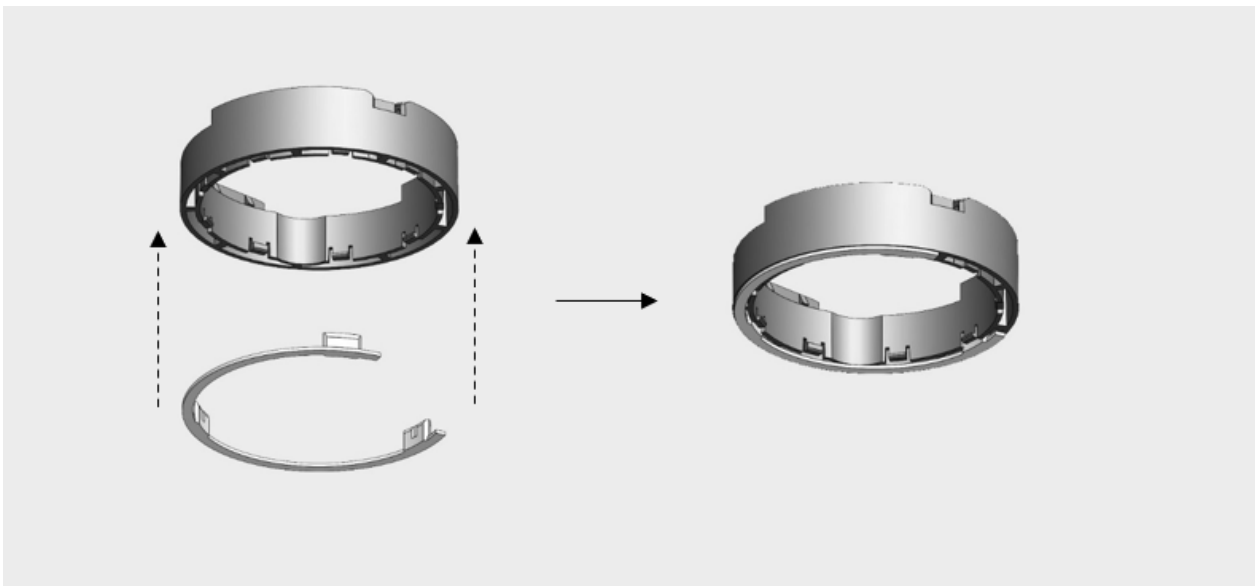

Fig. 18. Mounting the locking ring on the intermediate ring.

3. Install the intermediate ring + locking ring assembly on the water meter counter guard by placing the intermediate ring at the water meter counter guard in such a way that the digit “3” located on the upper edge of the intermediate ring is directly above the “3” mark visible on the water meter counter guard. While performing the actions described in section 3, adjust the position of the intermediate ring attachments in relation to the arrangement of snap-on detents on the cylindrical part of the water meter counter guard.

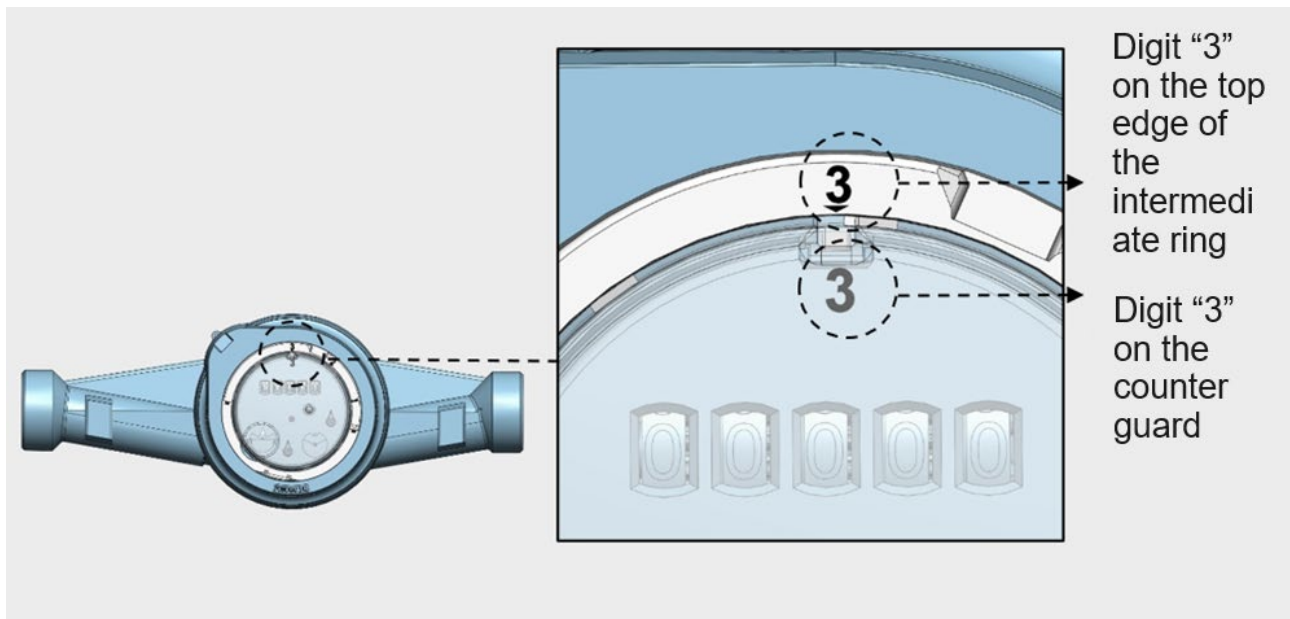

Fig. 19. Intermediate ring installation on the JS Master+ water meter counter guard.

4. Use both hands to press down the intermediate ring firmly on the water meter counter guard until a loud “click” is heard.
5. Check the correctness of the intermediate ring sub-assembly's mounting by attempting to remove it without using force.

5.3.2 Installation of the pulse module

1. Position the clip-on module over the intermediate ring secured on the counter guard so that the “2&3” mark on the module side wall is over the “Δ” mark on the top edge of the intermediate retaining ring.

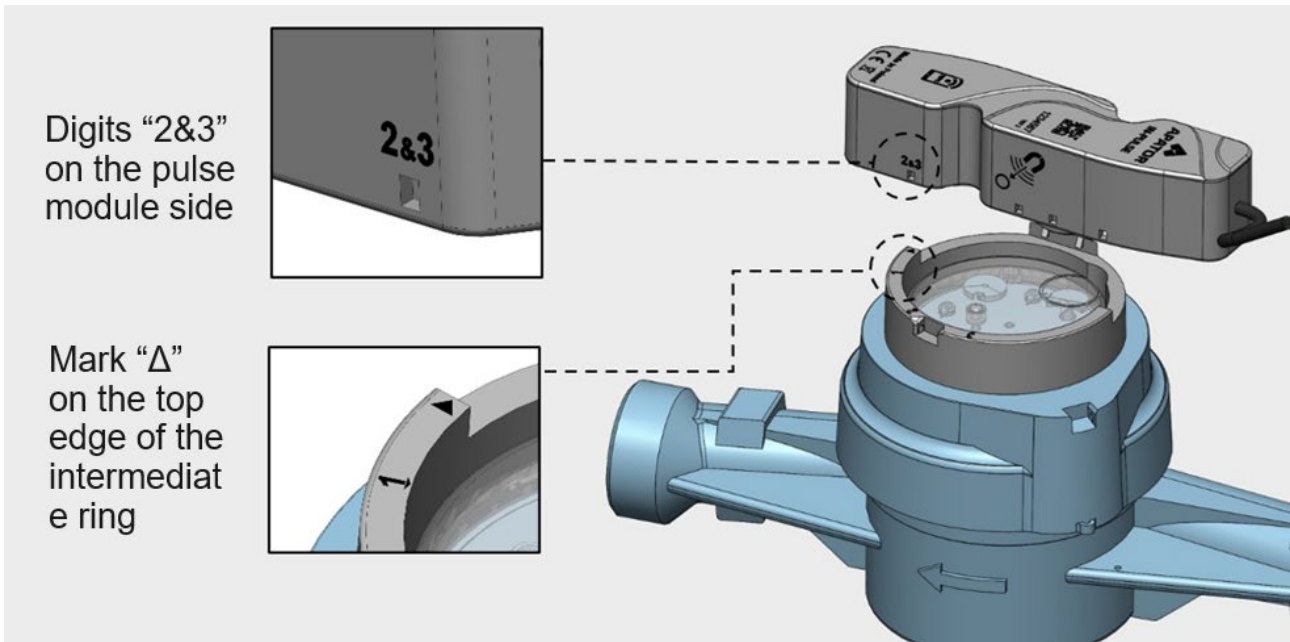

Fig. 20. Aligning the pulse module over the intermediate ring

2. Insert the transmission module into the intermediate ring recess on one side, so that two snap tabs of the intermediate ring (A) are inserted into two snap-on detents of the module, then press the module from the top to the ring so that the snaps on the opposite side of the module (B) are engaged.

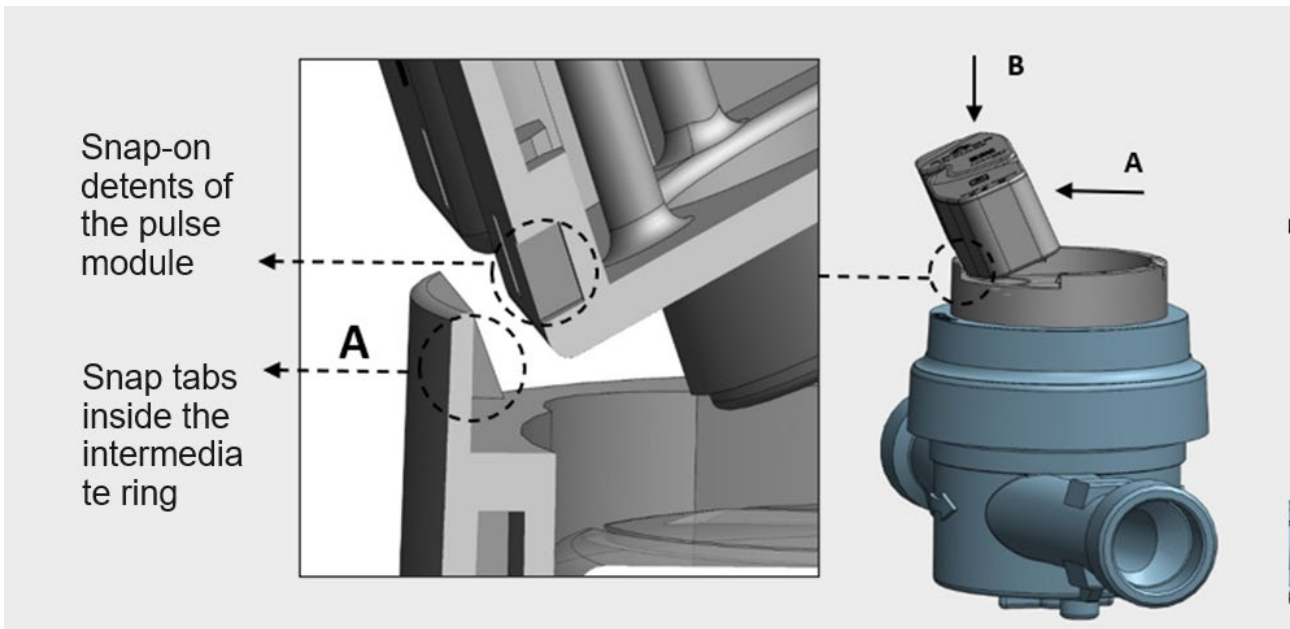
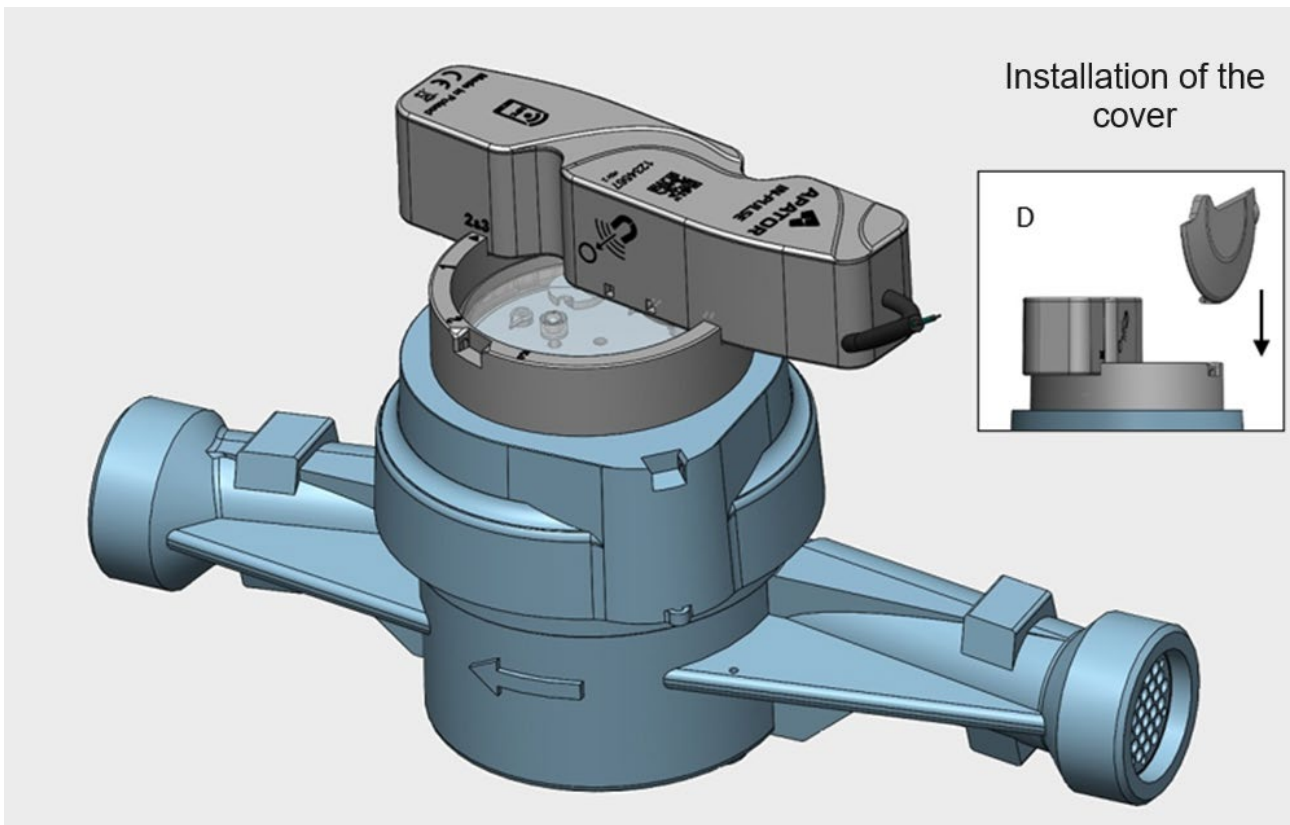

Fig. 21. Fastening the pulse module to the intermediate ring.

3. Check the correctness of the intermediate ring and module's mounting by attempting to remove it without using force. Then install the safety cover (D) on the intermediate ring.



*Fig. 22. IN-PULSE induction module correctly installed on a house water meter
in IP65 version.*

5.4 Installation on a house water meter, type JS Master (DN25÷DN40; T50) in IP68 version

1. The JS Master water meter in IP68 version is standard equipped with a special counter guard with a #UTIP (Universal TI Plug) used for communication module installation. Remove the cover before installing the communication module.

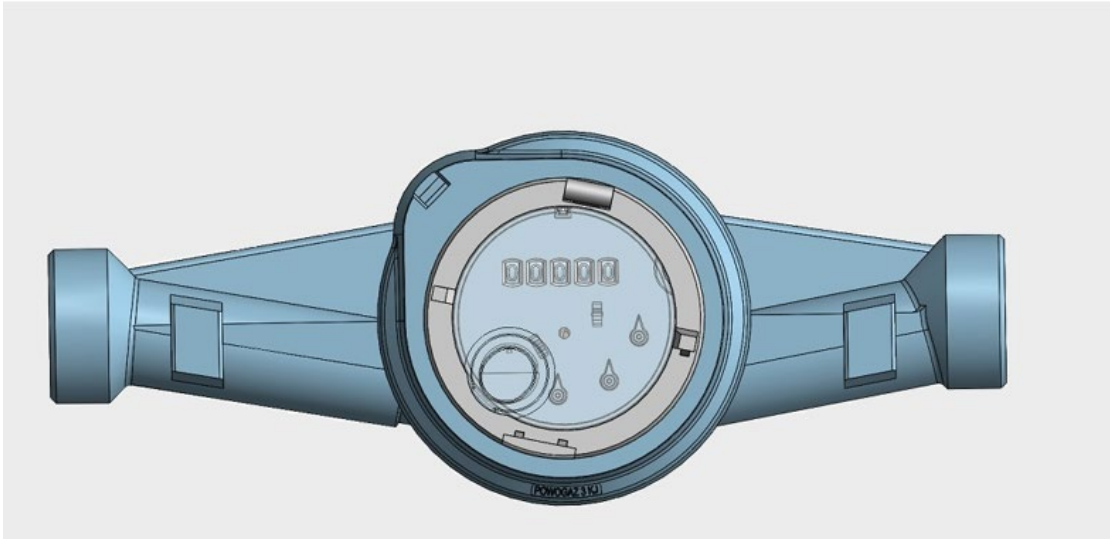

Fig. 23. JS Master water meter in the IP68 version without cover.

2. Position the IN-PULSE module over the counter guard so that the “2&3” mark on the module side wall is over the attachment (shown below) in the counter guard.

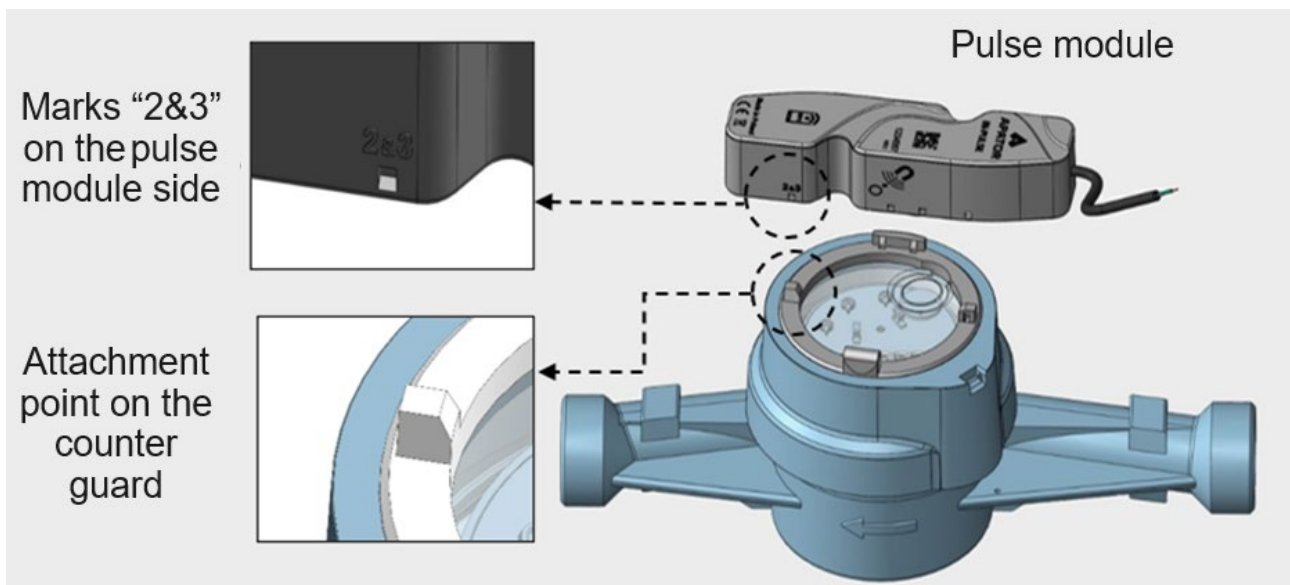

Fig. 24. Positioning of the IN-PULSE induction module above the counter guard.

3. Insert the clip-on module into the counter guard recess on one side, so that two snap tabs of the counter guard (A) are inserted into two snap-on detents of the module, then press the module from the top to the ring so that the snaps on the opposite side of the guard (B) are engaged.

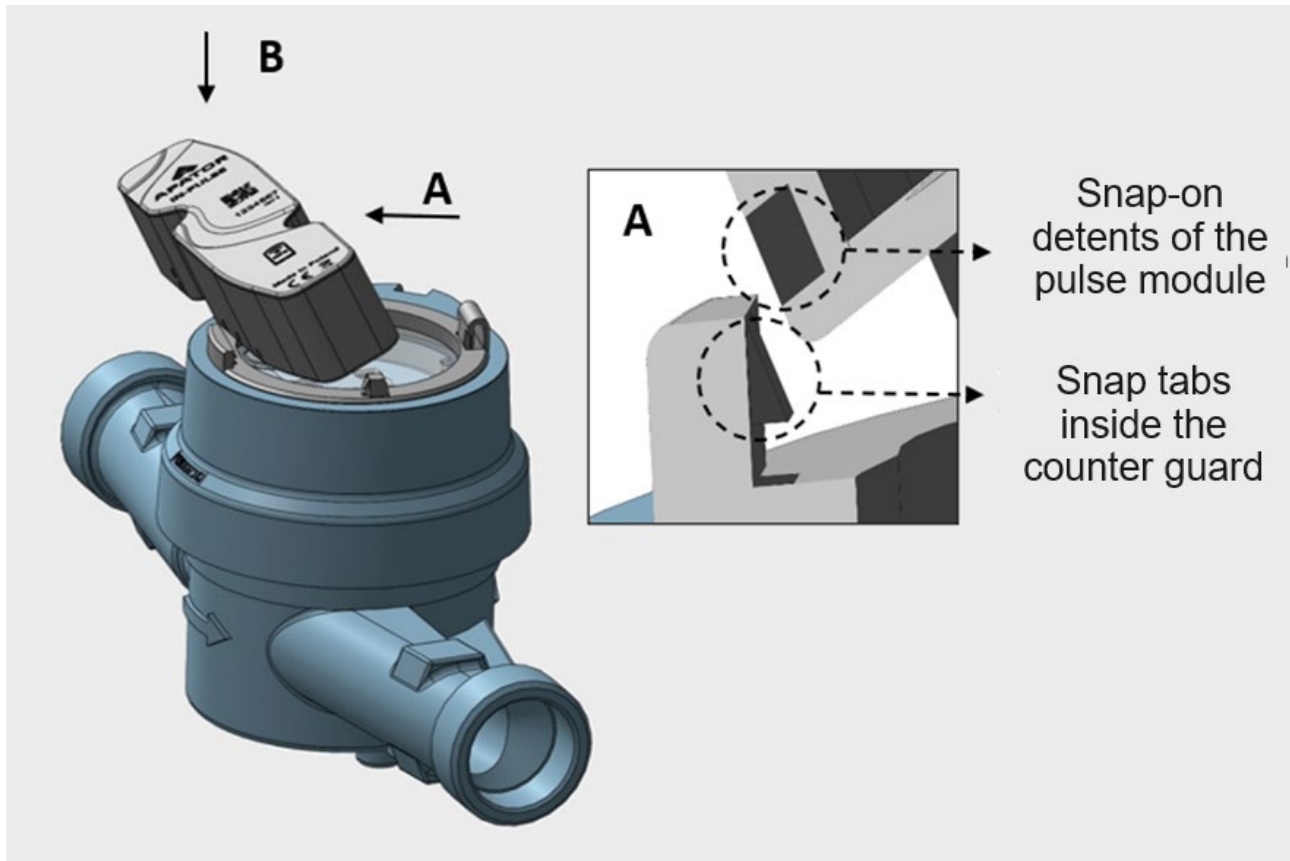

Fig. 25. IN-PULSE induction module installation on the water meter guard intermediate ring.

4. Install the module lock (C) and check the correctness of the IN-PULSE module's mounting by attempting to remove it without using force, then install the cover (D) shielding the counter barrels.

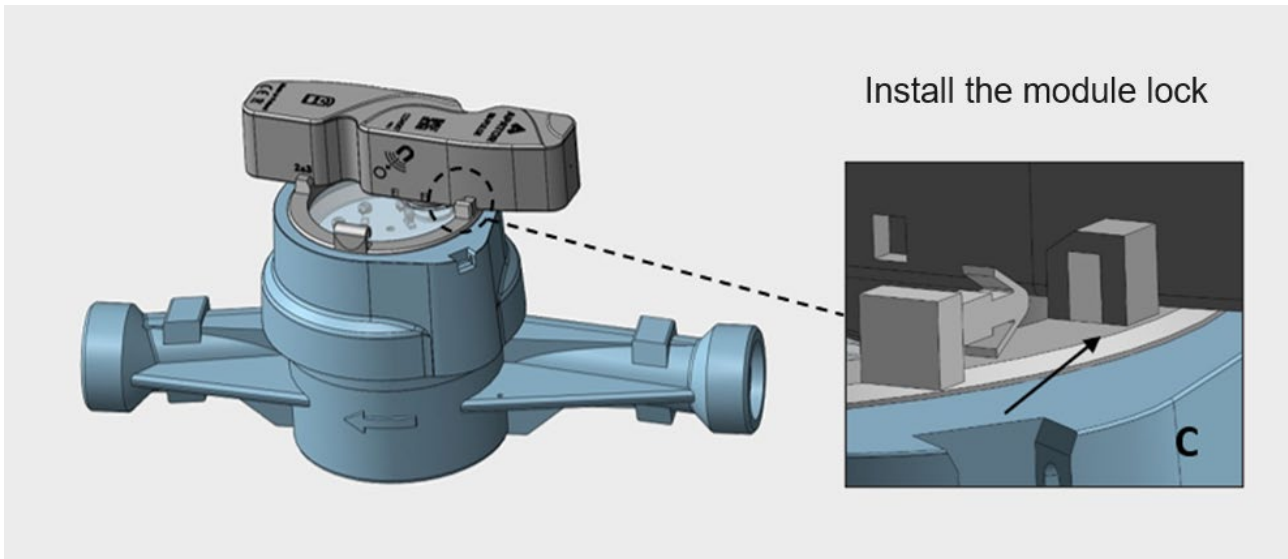

Fig. 26. IN-PULSE induction module installed on a residential water meter, along with a fitted ring lock.

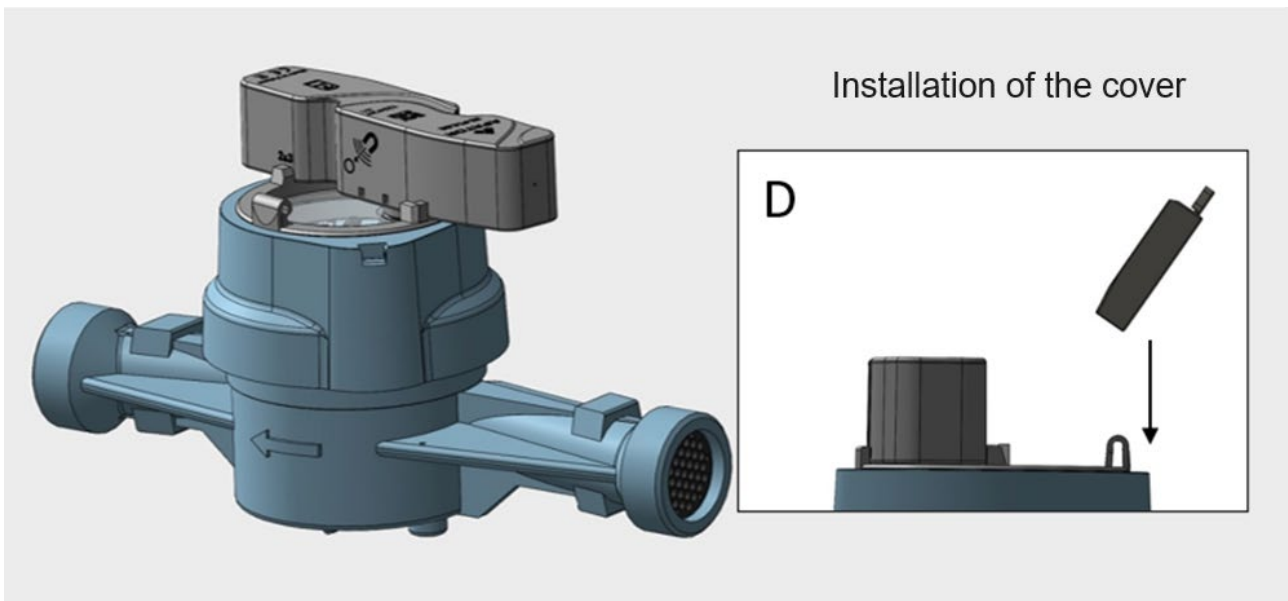

Fig. 27. IN-PULSE induction module correctly installed on a house water meter in IP68 version.

5.5 Installation on industrial water meter type MWN (T50; T130), JS(T50), MK(T50), MH(T50); in IP65 version

5.5.1 Fastening the intermediate ring on the counter guard

1. Industrial water meter type MWN in IP65 version The transmission module installation process in other types of industrial water meters (JS; MK; MH) is similar. Remove the cover from the intermediate ring. Mount the intermediate ring on the water meter counter guard so that the “2” mark on the top edge of the retaining ring is located directly over the “2” mark on the water meter counter guard. Use both hands to press down the retaining ring firmly on the water meter counter until a loud “click” is heard.

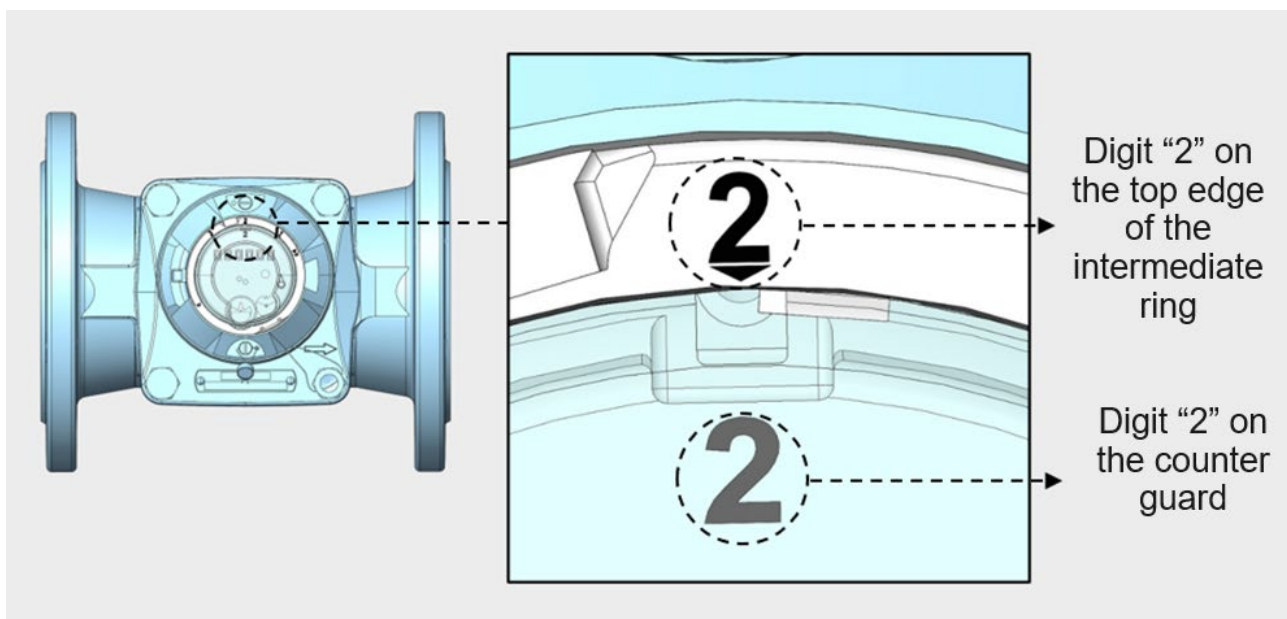

Fig. 28. Mounting the retaining ring on the counter mechanism cover.

5.5.2 Installation of the pulse module

2. Position the transmission module over the intermediate ring secured on the counter guard so that the “2&3” mark on the module side wall is over the “Δ” mark on the top edge of the retaining ring.

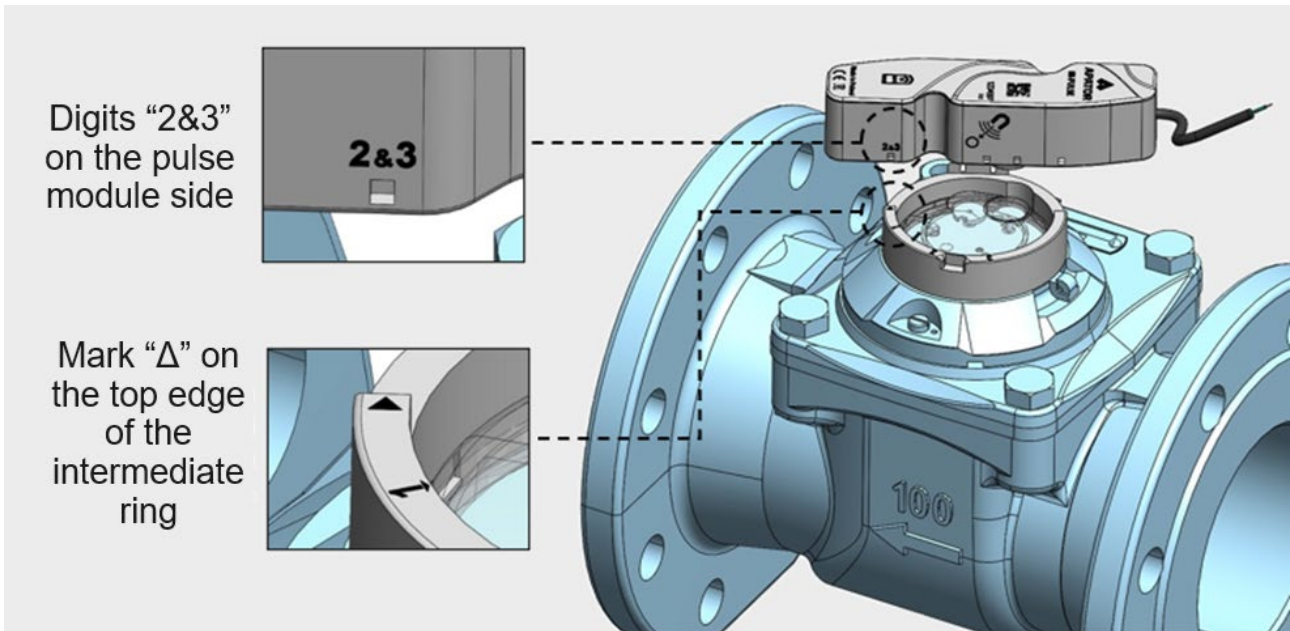

Fig. 29. Aligning the pulse module over the intermediate ring.

3. Insert the module into the retaining ring recess on one side, so that two snap tabs of the retaining ring (A) are inserted into two snap-on detents of the module, then press the module from the top to the ring so that the snaps on the opposite side of the ring (B) are engaged.

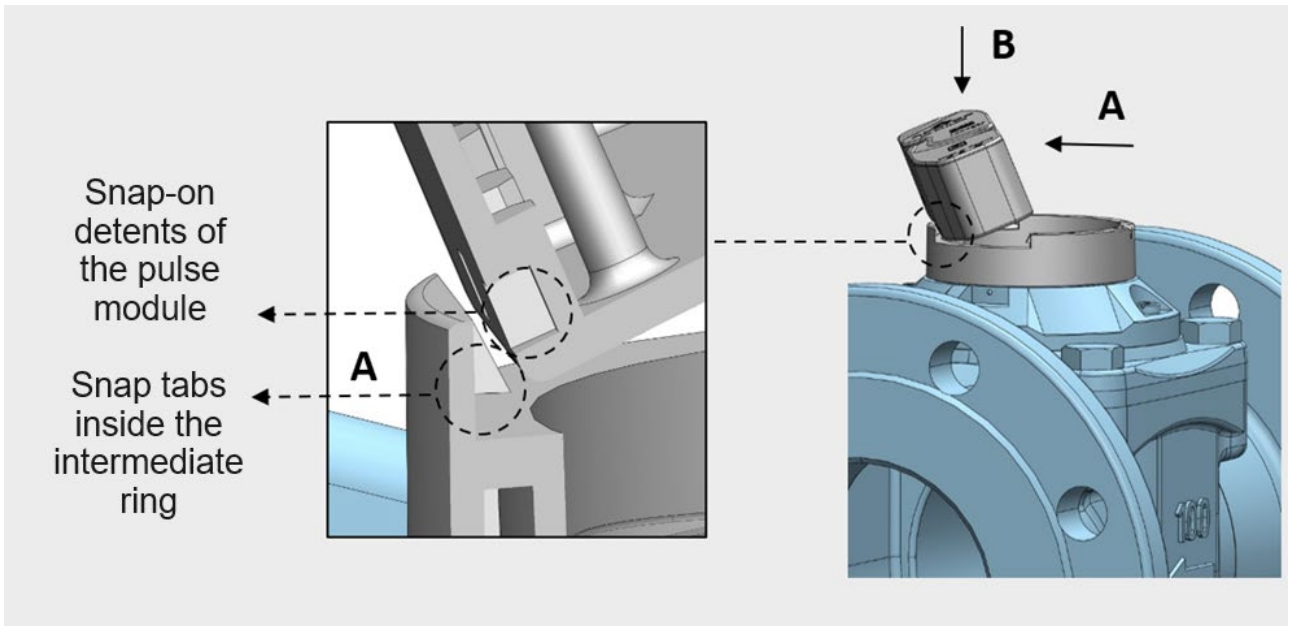

Fig. 30. Mounting of the IN-PULSE induction module on the intermediate ring.

4. Check the correctness of the retaining ring and module's mounting by attempting to remove it without using force, and install the cover (D) shielding the counter barrels.

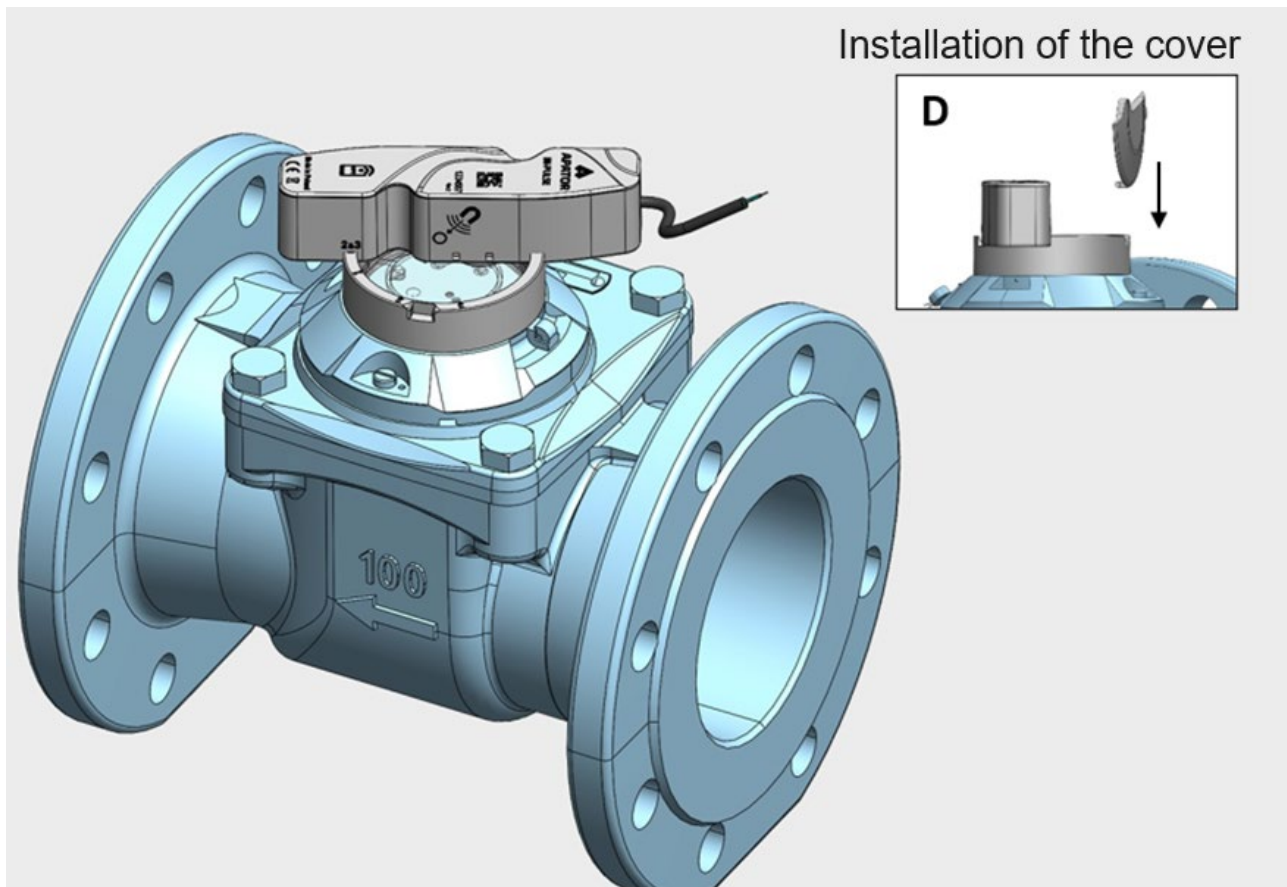

Fig. 31. IN-PULSE induction module correctly installed on an industrial water meter in IP65 version.

5.6 Installation on industrial water meters type MWN (T50), JS (T50), MK (T50), MH (T50) in IP68 version

1. Industrial water meter type MWN in IP68 version which is standard equipped with a special counter guard with a #UTIP (Universal TI Plug) connector used for transmission module mounting. The module installation process in other types of industrial water meters (IP68) is similar. Before installing the module, remove the counter guard cover.

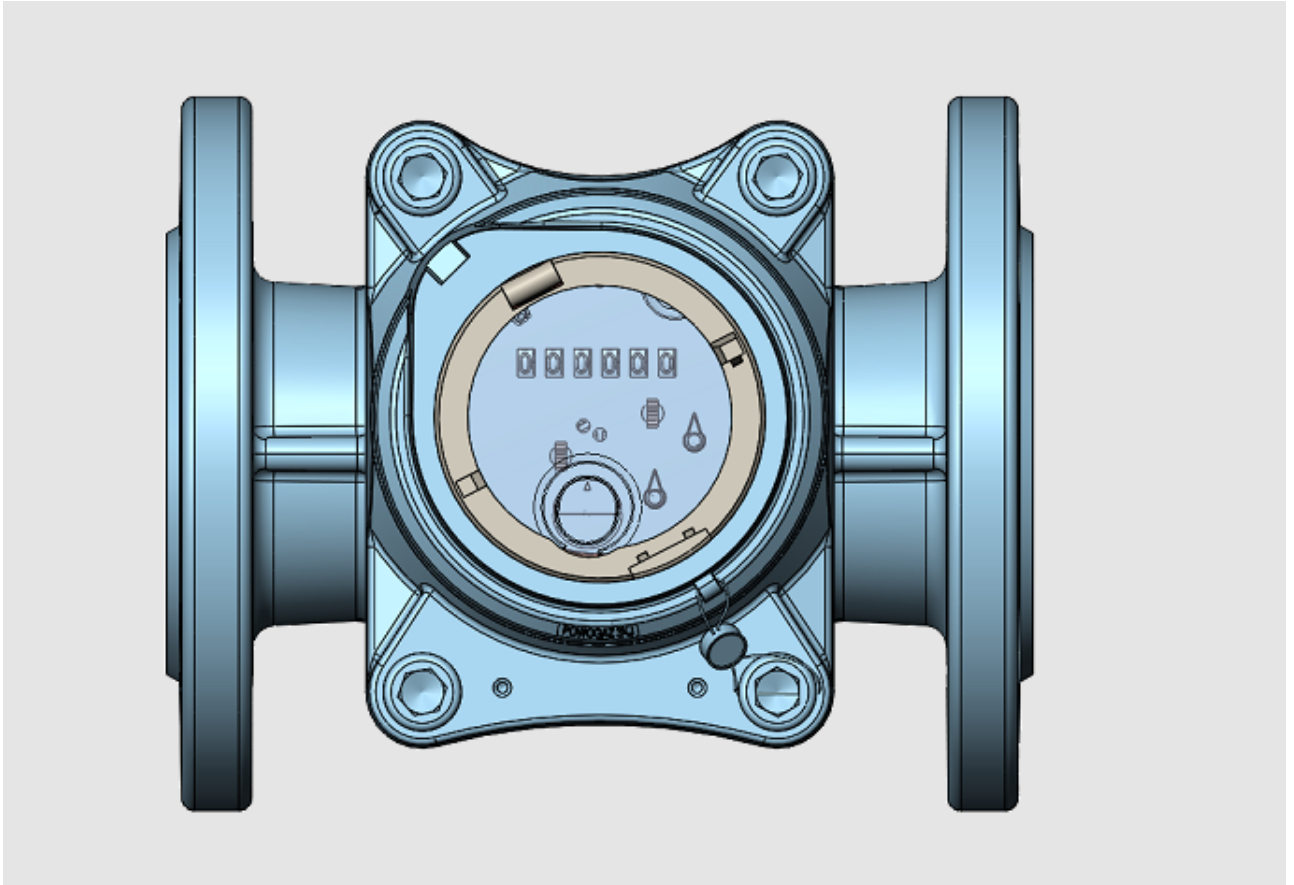

Fig. 32. MWN industrial water meter in IP68 version.

2. Position the IN-PULSE transmission module over the counter guard so that the “2&3” mark on the module side wall is over the attachment (shown below) in the counter guard.

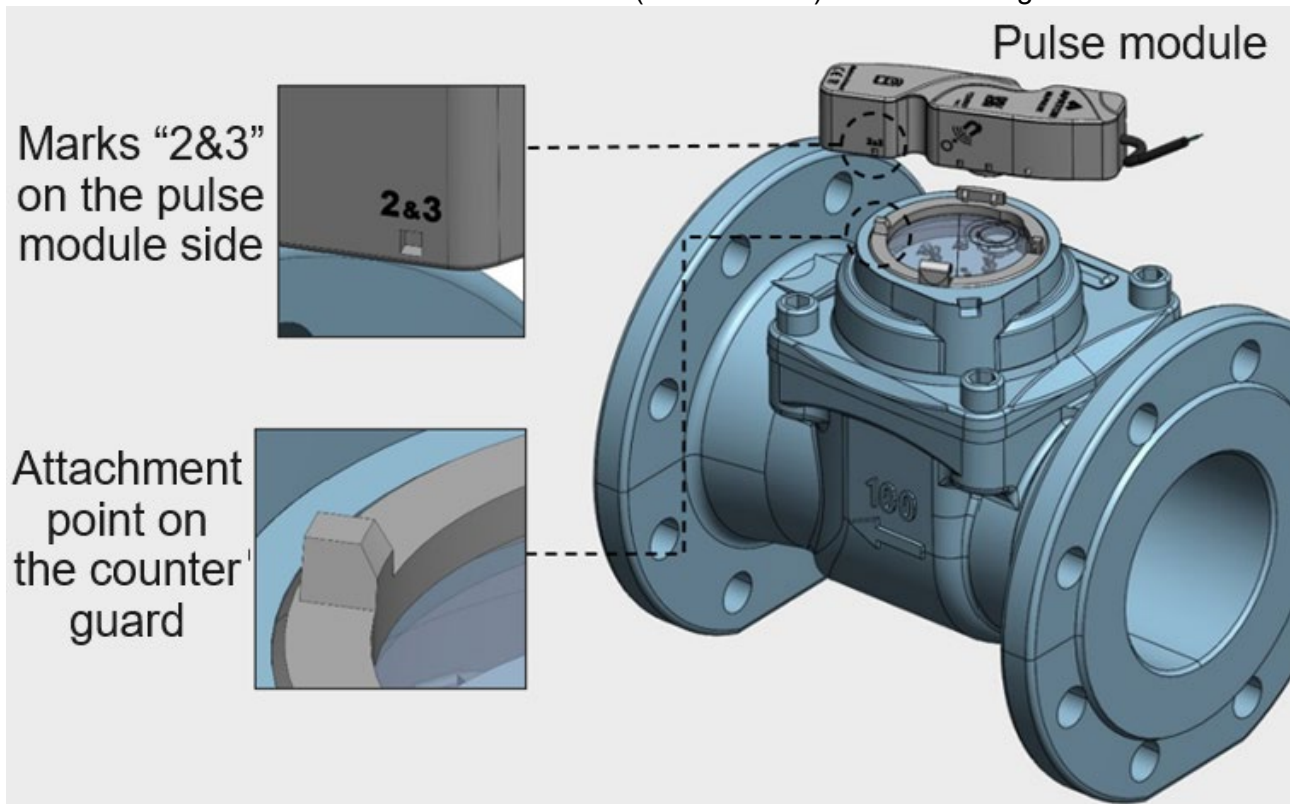

Fig. 33. IN-PULSE induction module positioning on the intermediate ring.

3. Insert the transmission module into the counter guard recess on one side, so that two snap tabs of the counter guard (A) are inserted into two snap-on detents of the module, then press the module from the top to the ring so that the snaps on the opposite side of the guard (B) are engaged.

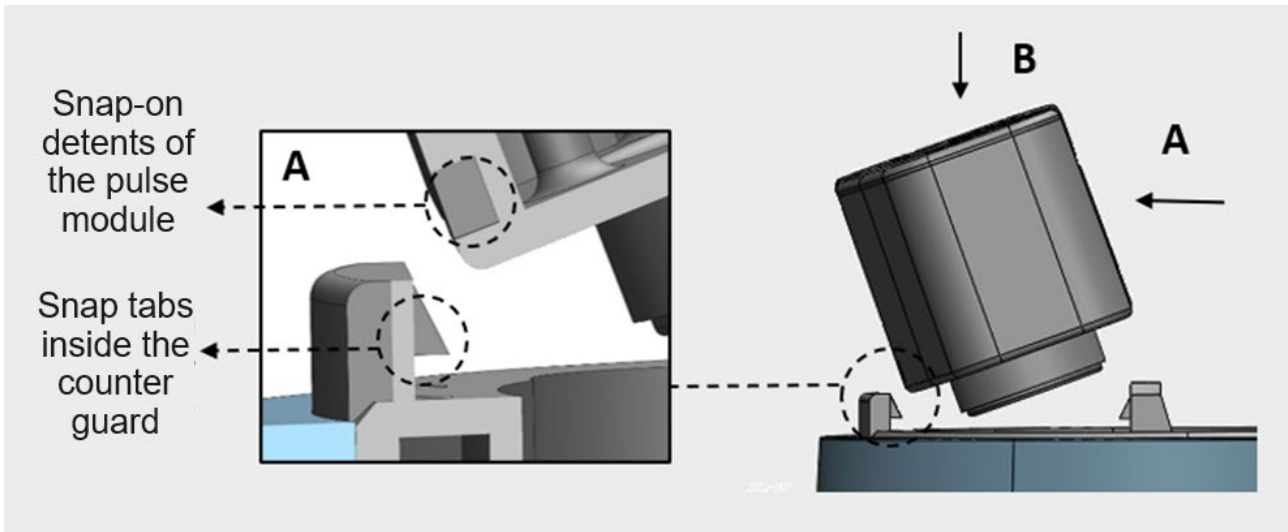

Fig. 34. Installation of the IN-PULSE inductive transmission module on the counter guard.

4. Install the module lock (C) and check the correctness of the IN-PULSE module's mounting by attempting to remove it without using force, then install the cover (D) shielding the counter barrels.

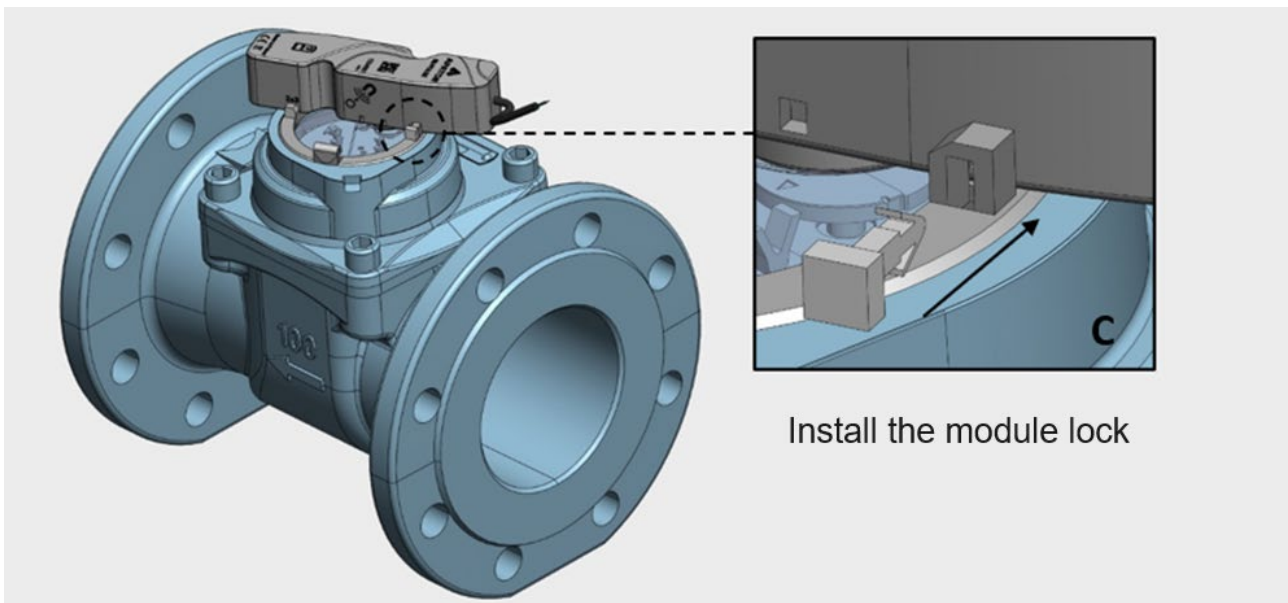

Fig. 35. IN-PULSE induction module installed on an IP68 industrial water meter with the module lock installed.

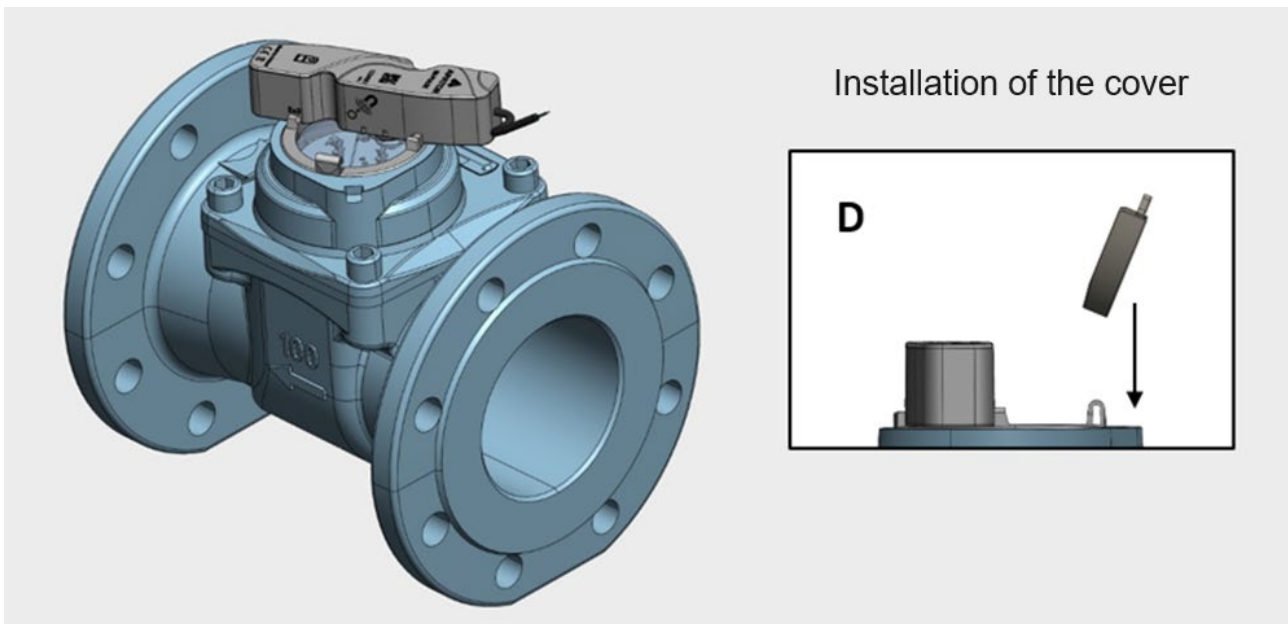

Fig. 36. IN-PULSE induction module correctly installed on an MWN industrial water meter in IP68 version.

6. Operation

6.1 Communicating with the module

The universal induction module is equipped with an near-field communication (NFC) interface, supported by a dedicated application. This app is used for various purposes such as: setting event detection, setting event thresholds, adjusting pulse weights, configuring pulse outputs and accessing historical data readouts, as well as details of events and alerts.

6.2 Recording and reading data by a pulse converter

The module transmits data related to flow using pulses.

Reading options:

- Device identification data (FW version and SN number)
- Nominal and consumed power (mAh)
- Current module counter indication
- Active and historical event flags
- Detailed event logger
- Output configuration (pulse mode set; alarm output setting flags enabled; pulse weight)
- Configuration of events – the events enabled to be logged by the module and their time of automatic deletion (switching of their active status off)

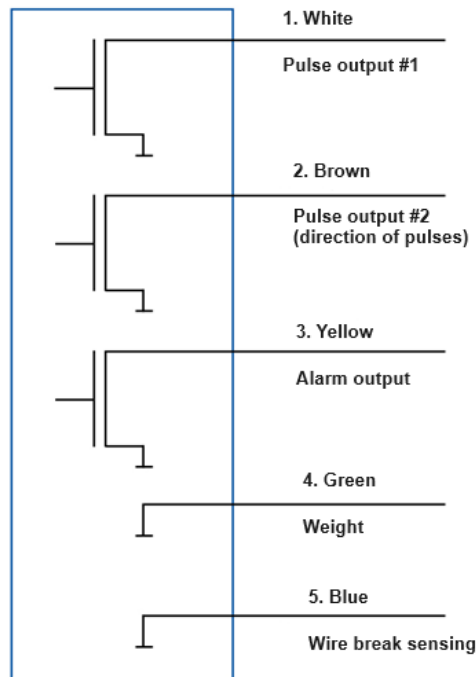

Fig. 37. Wiring connection diagram for the IN-PULSE module.

6.3 RTC (real time clock)

The module is equipped with a hardware real-time clock managed by the device's software. Due to variations in the operating conditions and natural ageing, the RTC can become out of sync by 20 minutes a year. It is recommended to update the RTC as frequently as required by the user.

6.4 Warehouse mode

After production, the module is in normal operating mode (other modes, such as warehouse mode, will not be implemented).

7. Device configuration

Proper operation of the IN-PULSE module in a reading system requires specific configuration settings of the module.

Configuration involves saving a selected profile from the internal profile database of the application dedicated by the Manufacturer to the IN-PULSE module through the NFC interface.

Uploading a profile to the device proceeds in the following steps:

1. Choose the type of device that the profile will be uploaded to,

2. For a specific type of device, select the profile that will be uploaded,
3. Enter the water meter serial number – this field is mandatory, without it, the operation cannot be initiated.
4. For the IN-Pulse module, the following additional fields must be completed:
 - a) Setting the pulse weight depending on the type of water meter, i.e. the count of water meter pointer full revolutions per single pulse output. Supported pulse weight options: 1; 2.5; 5; 10; 25; 100; 1000 r/pulse,
 - b) Adoption of one of the 4 variants of pulse generation at the pulse outputs,
 - c) Defining event flags, event details.
5. After making a selection, the user can start the action by clicking the “Execute” button. Next, you need to place the phone against the module. As soon as the application detects the module, the profile uploading process will begin.

Remark: To ensure uncorrupted and valid data, the module must remain properly mounted on the water meter while being configured, and during the configuration of pulse outputs, there should be no flow through the water meter.

The NFC interface of the device additionally enables:

- Setting the meter indication – forward flow, backflow, and balanced flow
- Setting the event detection (magnetic field proximity, device removal, and more)
- Setting the backflow event threshold:
 - Reverse volume
 - Back flow;
- Date and time updates
- Pulse output configuration
- Setting the auto calibration parameters

Pulse output modes:

1. Pulse per fixed revolution count – one output generates a forward flow pulse only per a fixed forward flow value; the other output generates a pulse per a fixed backflow value,
2. Pulse per fixed balance volume – a pulse is generated per a fixed balance volume on both pulse outputs according to the mechanical counter reading,
3. Pulse per fixed revolution count, irrespective of the direction of flow, on one pulse output with the identification of the flow direction on the other pulse output,
4. Pulse per fixed revolution count for forward flow; the other pulse output provides identification of the direction of flow (for backflow detection).

7.1 Automatic calibration of the counter mechanism

The IN-PULSE modules are universal devices compatible with the water meter types and counters specified in this Manual.

The following procedure is recommended:

- Close the stop valves upstream and downstream of the metering location before installing the module on the water meter.
- With the module installed on the water meter, exit the warehouse mode.
- With the module in the operating mode, set its configuration parameters and delete events (it is highly recommended to validate the data once the configuration has been set).
- If the configuration is correct, open the valves at the measurement point.

7.2 Indicator revolution weight

The module counts the revolutions of the dedicated induction interface indicator. Hence, proper operation of the module with a water meter first requires setting the indicator revolution weight in the module configuration. The indicator revolution weight is the volume of water which passes through the water meter during one full rotation of the induction interface indicator. Table 1 lists the pulse weight values for Apator Powogaz water meters.

7.3 Alarms, events, event thresholds

Events – Types

The module records events according to internal algorithms. Whenever an event is detected, the module will flag it as active until the event ceases. The data of event type, time, and number of instances are stored in the module memory. The following events are indicated:

- Backflow (per preset thresholds)
- Low battery
- Magnetic field
- Device disconnected (the module detected is removed from the water meter)
- Battery disconnected
- Maximum overtemperature ($> 60^{\circ}\text{C}$)
- Minimum undertemperature ($< -15^{\circ}\text{C}$)

Alarms

Alarms are instances of specific events – their occurrence changes the status of the alarm output (yellow wire) from high to low. The events listed below can be enabled in the configuration to switch over the alarm output.

Alarms – Available events

- Magnetic field
- Device disconnected
- Reverse flow
- Low battery

Like for regular events, the details of alarm event instance number and times are stored in the event logger.

Event logger – Details

- Event code
- Number (quantity) of specific event instances
- Specific alarm type instance start (since the last time the alarm details were reset)
- Specific alarm type instance end (since the last time the alarm details were reset)
- Other alarm type-specific required parameters (e.g. for removal detection: information on attenuation detected on specific coils is included).

Event thresholds

Event thresholds are parameters which must be saved in the module configuration according to the product data sheet of the water meter for the module to properly detect the instances of:

- Low battery,
- Reverse flow,
- External magnetic field detection,
- Removal detection.

8. Regulatory and standards compliance

- PN-EN 60947-5-6, Low-voltage switchgear and controlgear – Part 5-6: Control circuit devices and switching elements – DC interface for proximity sensors and switching amplifiers (NAMUR), included in Directive 2014/30/EU
- PN-EN 1434-2, Thermal energy meters – Part 2: Constructional requirements, included in Directive 2014/32/EU
- Classification of mechanical environment conditions: Class M1 – according to the Regulation of the Polish Minister of Economy of 18 December 2006.
- Classification of electromagnetic environment conditions: Class E2 – according to the Regulation of the Polish Minister of Development of 02 June 2016.

9. Removal

Before removing the clip-on module, transmission must be forced to save the current data from the module.

Procedure for removing an IP65 version device from a water meter:

- Hold the intermediate ring with one hand.
- With the other hand, tilt the module outwards in relation to the centre of the water meter so that the module comes out from the retaining ring snaps.

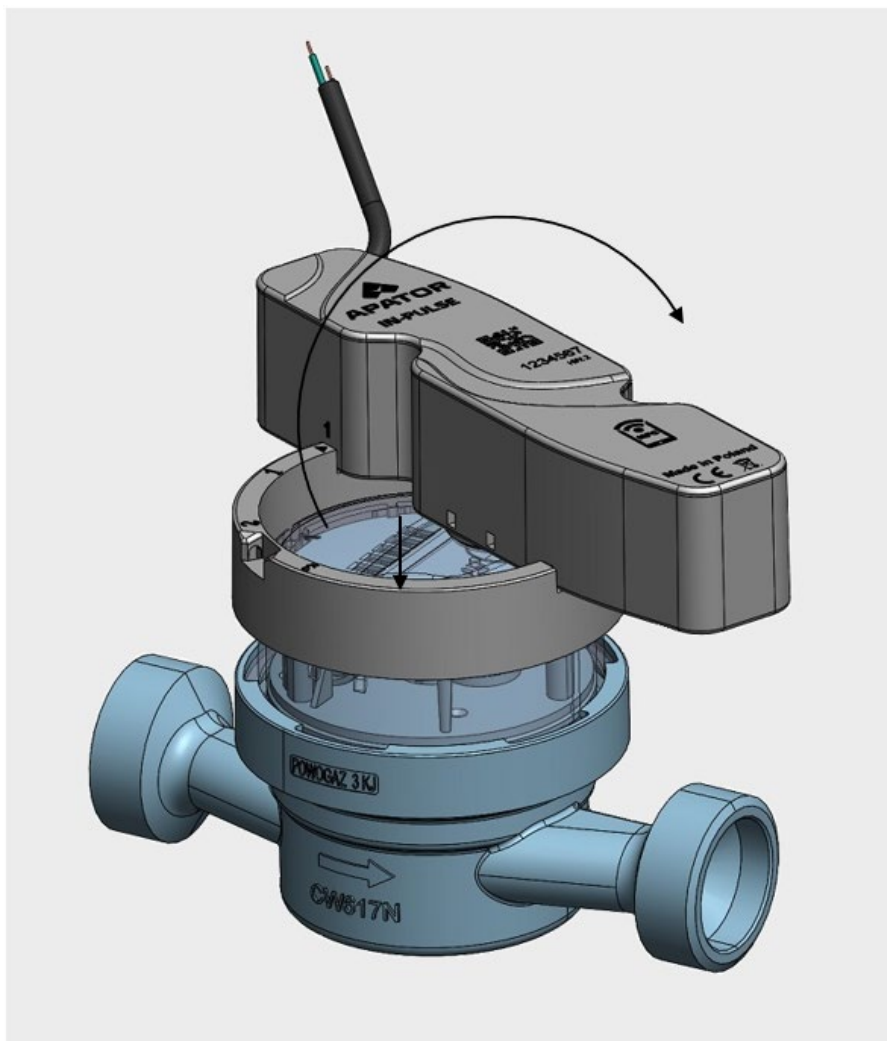

Fig. 38. Removing an IN-PULSE transmission module from an IP65 water meter.

- Prise the intermediate ring from the top with a small flat screwdriver right next to the attachment. Do not prise it directly at the attachment location!. This may result in its damage causing the clip-on module to fall from the water meter.

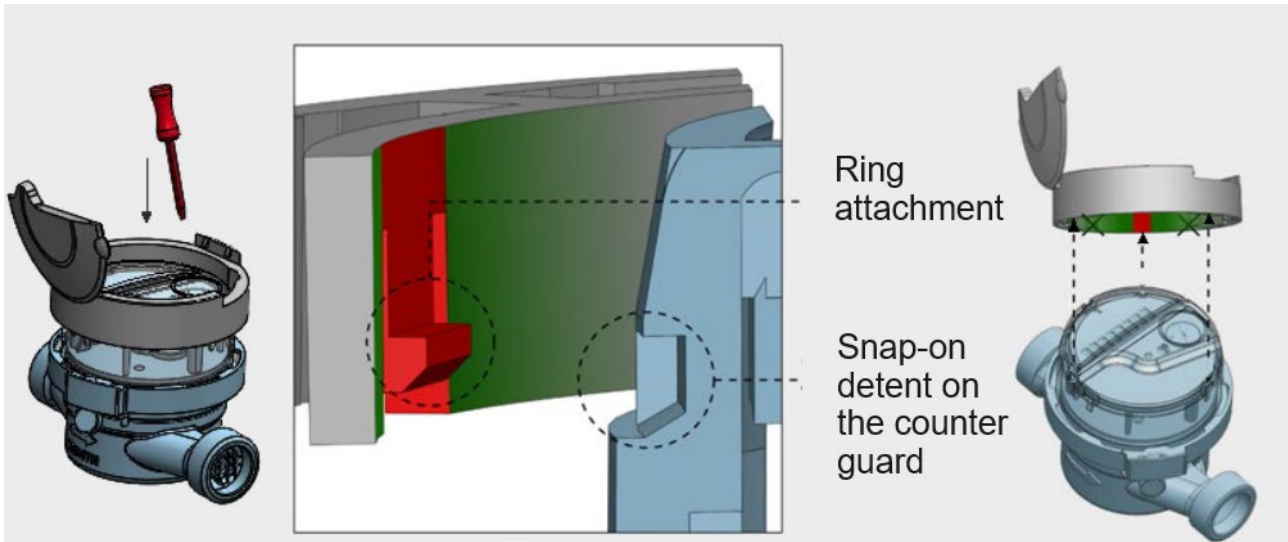

Fig. 39. The red field indicates the location in which prising the attachments may result in their damage.

Procedure for removing an IP68 version transmission module from a water meter:

- Remove the module lock by prying it with a sharp tool, e.g., a screwdriver,

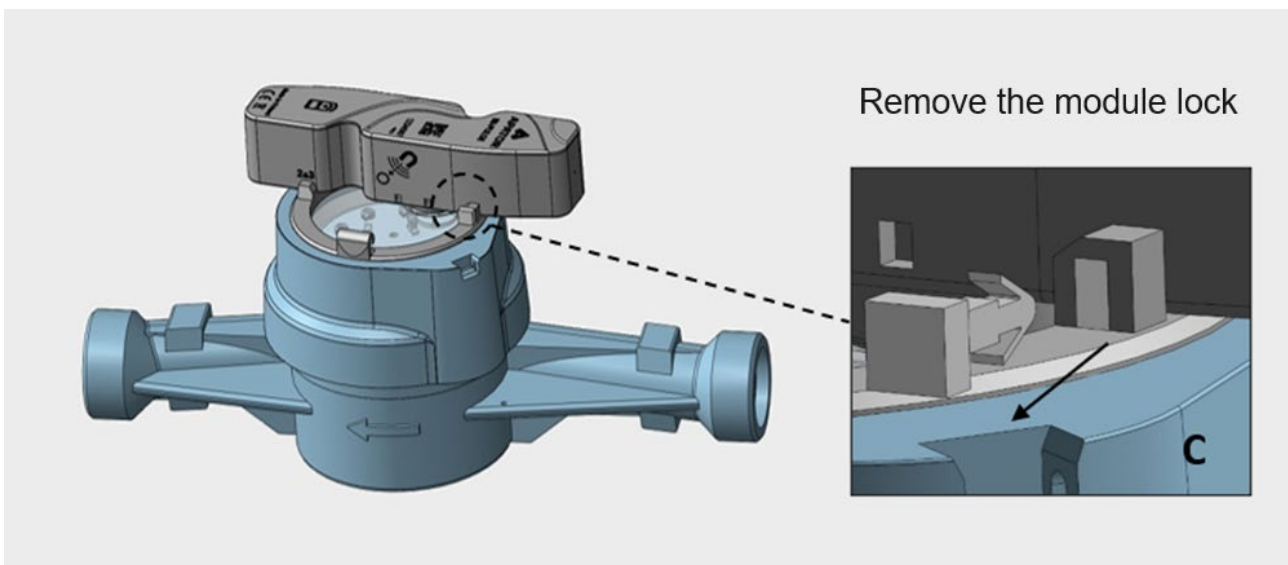

Fig. 40. Removing a module lock from a IP68 water meter.

- Hold the water meter with one hand, tilt the transmission module outward with the other hand in relation to the centre of the water meter, so that the module comes out from the counter guard snaps.

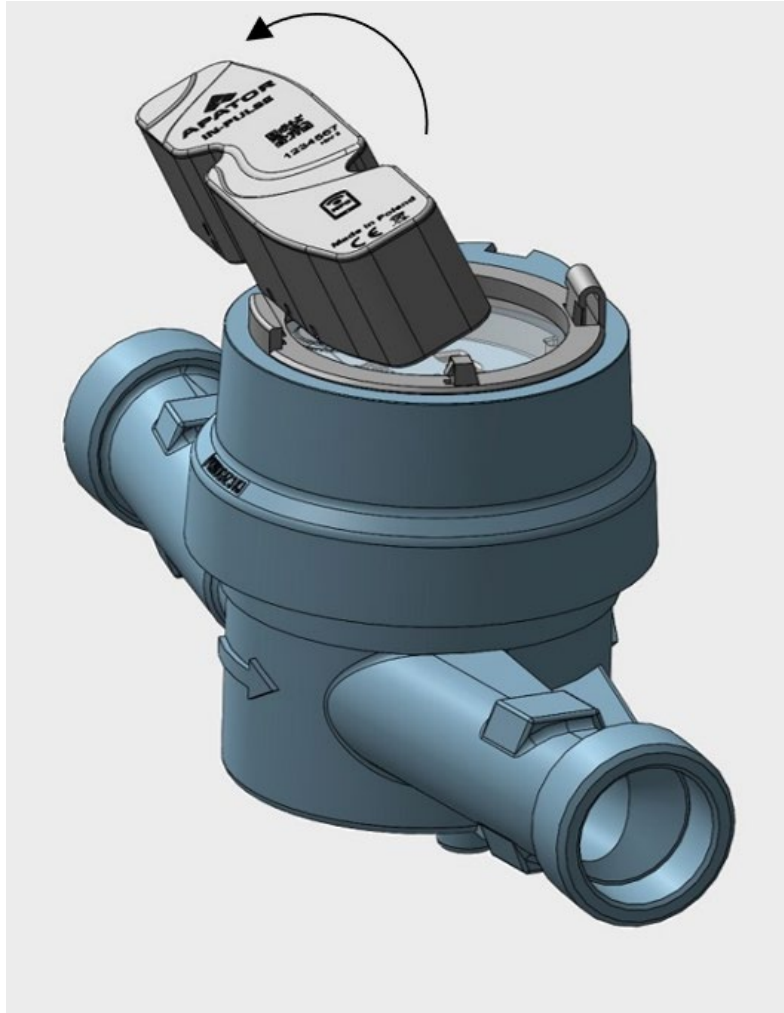

Fig. 41. Removing an IN-PULSE module from an IP68 water meter.

10. Operating precautions



The product must be protected against impact and shock during transport and kept at temperatures between -20°C and +70°C (the maximum temperature is allowed for less than 3 days).



Store the product at temperatures between +5°C and 35°C.



Having installed the product on a water meter, exit the warehouse mode and set the configuration as explained in this manual.



Operate the device in line with the parameters provided in specified in the technical data in section 3, at ambient temperatures and other environmental conditions consistent with the values determined in the manual.

11. Warranty terms and conditions

Apator Powogaz guarantees proper performance of the product for the duration specified in § 2 of the Apator-Powogaz General Warranty Terms & Conditions, only if the requirements specified for transport, storage and operation are followed.

12. Environmental protection

Do not dispose of with regular waste. Return the product to a WEEE collection point for disposal. Help protect the natural environment.



Revision history

Date	Version	Author	Description
01/03/2022	1.0	Janusz Geisel	First edition
30/10/2023	1.0	Tomasz Szulc	Second edition

Apator Powogaz S.A. has the right to modify and improve the manufactured equipment without prior notice.



Apator Powogaz S.A.

Jaryszki 1c, 62-023 Żerniki

Secretariat: sekretariat.powogaz@apator.com, tel. +48 61 84 18 101

Sales/Customer Service: tel. +48 61 84 18 149

Customer Service Support: handel.powogaz@apator.com

Export Department: export.powogaz@apator.com

Technical Support: support.powogaz@apator.com, tel. +48 61 8418 131, 134, 294

Warranty Claims: reklamacje.powogaz@apator.com

www.apator.com