

HEAT METERING



INVONIC H

ULTRASONIC HEAT AND COOLING METERS
DN15, DN20, DN25, DN40, DN50, DN65, DN80, DN100



INVONIC H is a modern and precise heat and cooling meter utilising an ultrasound flow transducer to guarantee high measurement precision for long term operation, regardless of the installation orientation. The heat meter has a modular structure, allowing a choice of optional features, such as communication module, power supply type, and alternative temperature sensors. A robust brass flow transducer is available in versions with a threaded or flanged connection, for use with the PN16 or PN25 pressure ranges. Heat meter indications are entirely unaffected by external magnetic fields.

APPLICATION

Heating/cooling systems in residential, office and industrial buildings, where the heating/cooling medium is water or water glycol (only DN15-50) solutions at temperatures up to 130°C. The flow transducer can be disconnected from the calculator, which allows installation in difficult locations and facilitates reading indications from the display. The heat meter may be installed in any working orientation and does not require the use of straight sections upstream or downstream of the flow transducer up to DN50. Remote reading of heating and cooling energy indications can be carried out by cable or wirelessly, and can be integrated with data reading and building automation systems.





INVONIC H

ADVANTAGES

A modern ultrasound heat and cooling meter, which allows archiving of a broad spectrum of data and configuration of parameters according to the clients' requirements

There is a possibility of data configuration and reading using an optical reading head

Replaceable communication modules:

- M-Bus
- Modbus RTU
- wM-Bus
- BACnet MS/TP

Two pulse outputs/inputs in the standard version

Operated using a single button located under the LCD display

Battery power supply with a possibility of a power network supply

The option of installing the INVONIC H heat meter as the compact or split version (cable length 1.2 m)

Total immunity to external EM fields.



ADVANTAGES

COST EFFECTIVENESS

- The guaranteed high measurement accuracy allows rational power management
- The measurement chamber contains no moving elements, to guarantee resistance to contamination and low pressure losses, which translates into less electricity needed to operate the circulation pumps
- The robust design of the meter combined with reliable electronics featuring minimal power consumption ensures long-term operation of the device, for up to 11 years

EASY INSTALLATION

- The small dimensions and split design make installation possible under any conditions, with convenient display of the readings
- The modular structure allows the replacement and installation of additional options (communication modules) without affecting the approval marks
- The option of threaded or flanged connections, as well as various flow transducer lengths, facilitates the use of the INVONIC H heat meter to modernize existing networks
- A temperature sensor may be installed within the flow transducer body (DN15-DN20)



CONVENIENT TO USE

- The IP65 or IP67 protection class of the flow transducer effectively protects the instrument against the negative results of steam condensation
- No wear of the measurement chamber elements during continuous operation, even with high flows
- Suitable for systems with a nominal pressure of 16 or 25 bar
- Suitable for heating and cooling systems, where water or water solutions of glycol** (max concentration: 47%), or ethylene (max concentration: 52%) are used as the medium
- The meter indications are unaffected by strong external magnetic fields
- The built-in recorder ensures storage of data from the last 36 months (for 15 years with no power supply)

MEASUREMENT PRECISION

- The high stability of the metrological parameters has been achieved across the entire operational period, by compensating for signal strength
- A broad measurement range of 1:100 and 1:250* in any orientation (H, V, H/V)
- The transducer activation threshold can be as low as 3 l/h
- Small pressure drops from 1 to 20 mbar for qp flow (pressure drop amount depending on the length of installation and the value of the nominal flow)

* Extending the measurement range to 1:250 is possible only for transducers with qp = 1.5; 2.5; 6; 10 and 15 m³/h

** with the exception of flow sensors with a nominal flow qp = 25 m³/h; 40 m³/h; 60 m³/h

REGULATORY AND STANDARD COMPLIANCE

- Measuring Instruments Directive (MID): 2014/32/EU module B + D: EN 1434-1/2/4/5/6:2015 (heat meters); EN 1434-3:2016
- OIML R75:2002
- Low Voltage Directive (LVD): 2014/35/EU, EN 61010-1:2010
- Radio Equipment Directive (RED): 2014/53/EU, ETSI EN 300 220-2:2012 V2.4.1
- Electromagnetic Compatibility (EMC) Directive: 2014/30/EU, EN61000-4-2:2009, EN61000-4-3:2006, EN61000-4-4:2012, EN61000-4-5:2014/A1:2017, EN61000-4-6:2014, EN61000-4-8:2010, EN61000-4-11:2004 : /A1:2017, EN 55022:2010
- type approval: LT-1621-MI004-029

M-BUS MODULE

- EN 1434-3:2015; EN 13757-3:2013; EN 1434-3:2007; EN 13757-2:2004

WM-BUS MODULE

- EN 1434-3:2015; EN 13757-3:2013; EN 13757-4:2013

MODBUS RTU / BACNET MS/TP MODULE

- EIA/TIA-485:1998

OPTICAL READING

- EN 62056-21:2002; EN 13757-3:2013

TEMPERATURE SENSORS

- EN 1434-2:2015; EN 60751:2008





COMMUNICATION

- An 8 position LCD display showing the meter operation status, operated with a single button
- Two built-in potential free pulse outputs, open collector type, used to send information about flow volume and energy, which may also be used as two pulse inputs, e.g. for water meters with a pulse generator
- An integrated optical interface for reading archive data and meter parameters
- M-Bus cable reading module
- Modbus RTU cable reading module (network power supply needed)
- wM-Bus wireless reading module
- BACnet MS/TP cable reading module (network power supply needed)
- Radio reading of indications is possible for a walk-by, drive-by system, as well as a stationary system
- The test mode implemented in the device make it possible to re-approve the meter at any approval station

LCD DISPLAY - FUNCTIONS



- 1 output-input no / tariff no / supply pipe
- 2 output-input no / tariff no / return pipe
- 1-2 difference between parameter values
- ← → liquid flow direction, no symbol means no flow
- M monthly archive data
- TEST test mode
- MAX maximum parameter value
- MIN minimum parameter value
- ❄ cooling energy
- ▼ current menu indicator
-  total indications and control data
-  measurement archive
-  momentary indications and meter configuration



- Error, Er: error
- in pulse input
- out pulse output
- 20 170623 date mark
- L1 tariff 1 configuration
- L2 tariff 2 configuration
- b: battery information
- n: serial number of the meter
- H: liquid type (water "—")
- Soft software version
- bu5A primary M-Bus address

REPLACEABLE COMMUNICATION MODULES

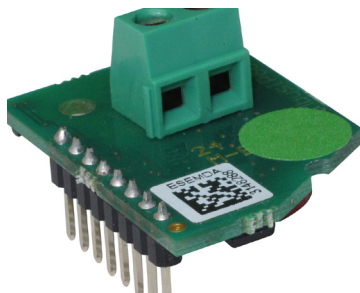

M-Bus

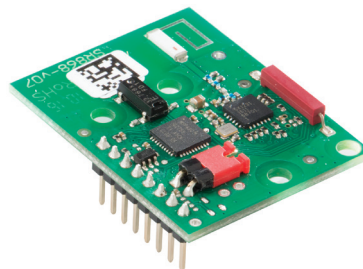

wM-Bus

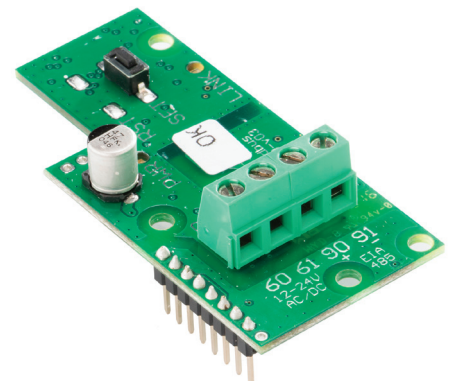

Modbus RTU / BACnet MS/TP

POWER SUPPLY

- The installed AA 3.6 V low-lithium battery (0.7 g) ensures the operation of a meter equipped only with pulse inputs-outputs for at least 11 years
- When using M-Bus/wM-Bus communication modules it is necessary to install an additional battery in the calculator and, in the case of the Modbus or BACnet module, an external power supply to ensure the required 11 years of device operation
- The device may be supplied from 2 batteries maximum or from one battery and a power supply module, which has an optional external power supply available.

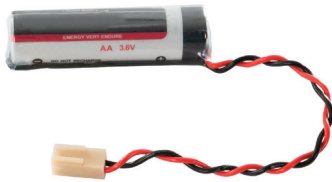

Battery

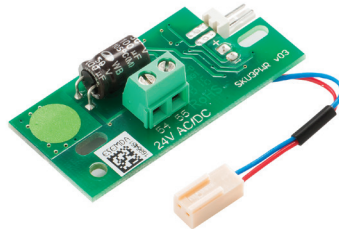

Power supply module



Power adapter

REMOTE TRANSFER OF INDICATIONS FROM THE HEAT METERS

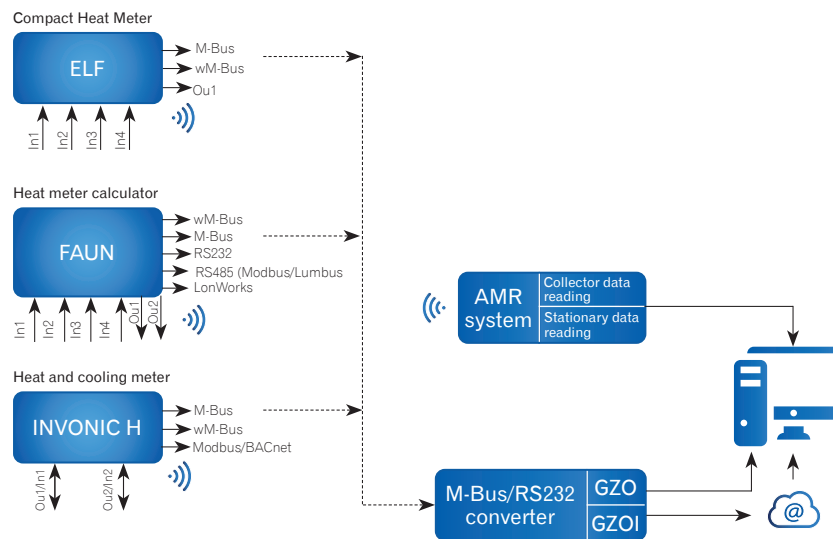

PRESSURE LOSS CHART

Pressure loss

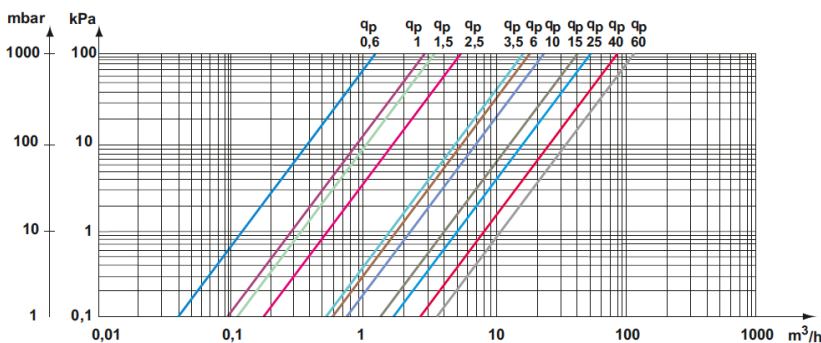

Table 1. TECHNICAL SPECIFICATIONS

Flow transducer																		
Nominal flow	q _p	m ³ /h	0.6		1.0		1.5			2.5		3.5	6	10	15	65	80	100
Nominal diameter	DN	–	DN15	DN20	DN15	DN20	DN15	DN20		DN20		DN25	DN25	DN40	DN50	DN65	DN80	DN100
Body length	L	mm	110	190	110	190	110	190	130	130	190	260	260	300	270	300	300	360
Connection type [G - threaded, K - flange]	–	–	G¾	G1 K	G¾	G1 K	G¾	G1 K	G1	G1	G1 K	G1¼ K	G1¼ K	G2 K	K	K	K	K
Minimum flow for the 1:100 measurement range	q _i	l/h	6	6	10	10	15	15	15	25	25	35	60	100	150	250	400	600
Minimum flow for the 1:250 measurement range	q _i	l/h	–	–	–	–	6	6	–	10	10	–	24	40	60	100	160	240
Starting flow	–	l/h	3	3	5	5	3	3	5	5	5	17	12	20	30	50	80	120
Maximum flow	q _s	m ³ /h	1.2	1.2	2	2	3	3	3	5	5	7	12	20	30	50	80	120
Pressure loss for flow q _p	–	kPa	7	0.9	11,3	2,5	17	5,8	7,2	20	9,4	4	10	18	12	20	18	18
Operating pressure	–	bar	PN16 or PN25															
Ingress protection	–	–	IP65 or IP67															
Permitted installation orientation	–	–	any (H, V, H/V)															
Flow disturbance sensitivity class	–	–	U0D0															
Ambient temperature in the workplace	–	°C	-30 – 55															
Storage and transport temperature	–	°C	-20 – 65															
Temperature scope of the flowing medium	θ _p	°C	5 – 130 **															
Measurement accuracy class	–	–	class 2															
Permitted threshold error of the flow transducer	E _f	%	E _f = (2 + 0.02 q _p /q), but no more than 5%															
Permitted media	–	–	water pH 7 – 9.5, water solutions of ethylene or propylene glycol															
Body material	–	–	brass															
Length of the line between the flow transducer and calculator	–	m	1.2															
Electronic calculator with temperature sensors																		
Ingress protection	–	–	IP65															
Temperature measurement range	θ	°C	0 – 180															
Temperature difference measurement range	Δθ	°C	3 – 150															
Temperature difference below which energy is not calculated	Δθ	°C	0.15															
Ambient temperature during operation	–	°C	5 – 55															
Storage and transport temperature	–	°C	-20 – 65															
Permitted relative air humidity	–	%	< 93															
Available power supply types	–	–	AA 3.6 V lithium battery (lifetime up to 11 years) external power supply 12-36 V AC / 12-42 V DC 230 V mains supply															
Measurement units	–	–	GJ, kWh, MWh, Gcal (available for selection); °C; m ³ ; m ³ /h															
Display	–	–	LCD, 8 positions															
Displayed values	–	–	energy, volume, flow, power, temperature															
Communication	–	–	optical port, 1 replaceable communication module (M-Bus, Modbus RTU, BACnet MS/TP, wM-Bus 868 MHz), 2 pulse outputs/inputs															
Data recorder saving frequency	–	–	hourly, daily, monthly															
Data recorder capacity	–	–	history of indications in recorders: up to 1,480 h, up to 1,130 days, up to 36 months															
Default pulse value (flow)	–	l/pulse	1 l/pulse (for q _p = 0.6-6 m ³ /h), 10 l/imp. (for q _p = 10-15 m ³ /h)															
Default pulse value (energy)	–	–	1 kWh/pulse or 0.005 GJ/pulse or 0.001 Gcal/pulse depending on the selected energy unit															
Permitted threshold error of the calculator (MPE)	E _c	%	E _c = ± (0.5 + Δθ _{min} / Δθ)															
Permitted temperature sensors	–	–	Pt500, ø 5.2, with two lines, maximum line length up to 5 m															
Maximum permissible error for a temperature sensor pair	E _t	%	E _t = ± (0.5 + 3 Δθ _{min} / Δθ)															
Electromagnetic environment conditions	–	–	Category E2															
Mechanical environment conditions	–	–	Class M1															
Climatic environment conditions	–	–	Class C															

** The provided minimum temperature applies only to the type approval. The heat meter is able to measure at increments of 0.01°C.

DIMENSIONS AND INSTALLATION

Calculator dimensions

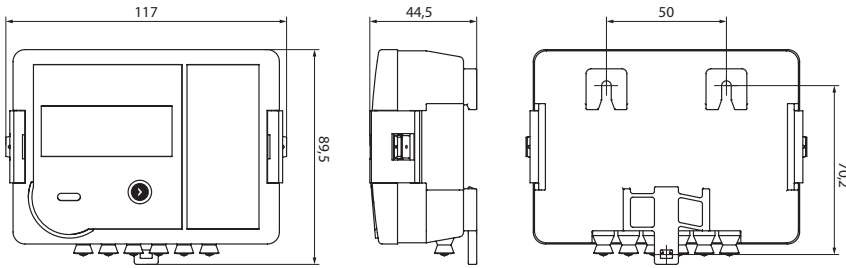

Dimensions of the flow transducer with a threaded connection

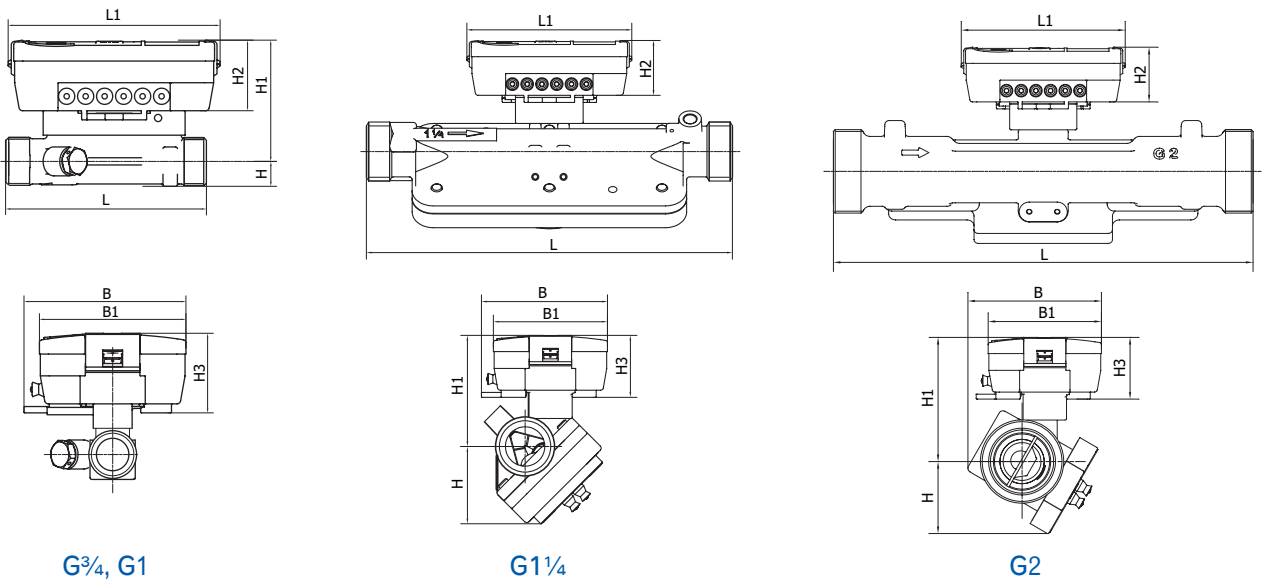

G^{3/4}, G1

G1 1/4

G2

Dimensions of the flow transducer with a flanged connection

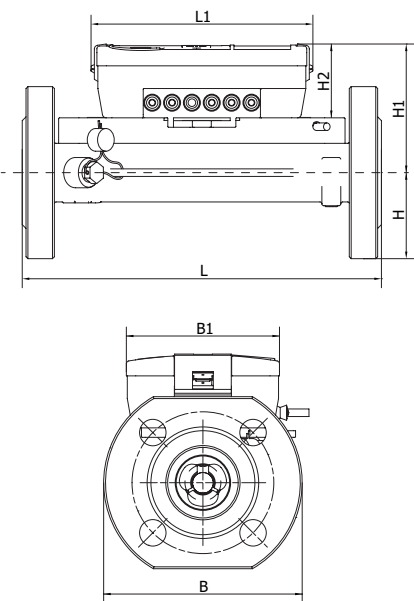

Table 2. BULK DIMENSIONS

Connection type		Threaded [G]					Flanged [K]						
		G ^{3/4}	G1	G1	G1 1/4	G2	DN20	DN25	DN40	DN50	DN65	DN80	DN100
Connection size													
Nominal diameter	– mm	15	20	20	25	40	20	25	40	50	65	80	100
Overall length	L mm	110	130	190	260	300	190	260	300	270	300	300	360
Calculator length	L1 mm	117	117	117	117	117	117	117	117	117	117	117	117
	H mm	14	18	18	55	51	46	58	75	79	83	90	108
Height	H1 mm	94	94	94	87	97	96	87	97	98	107	110	127
	H2 mm	39	39	39	39	39	39	39	39	39	39	39	39
Calculator height	H3 mm	44	44	44	44	44	44	44	44	44	44	44	44
Total width:	B mm	90	90	90	90	97	105	116	150	159	165	180	215
Calculator width	B1 mm	81	81	81	81	81	81	81	81	81	81	81	81
Weight	– kg	0.8	0.9	1.1	3.6	7.4	2.9	6.1	9.2	8.5	13	15	18

DN20, DN25, DN40, DN50, DN65, DN80, DN100

Data presented in the sheet is current for the day of the publication.
The manufacturer retains the right to modify and improve the products without prior notice.
This publication is intended for information purposes only and shall not be construed as a commercial offer under the Polish Civil Code.



Apator Powogaz S.A.
ul. Klemensa Janickiego 23/25, 60-542 Poznań
e-mail: handel.powogaz@apator.com
Office: phone +48 61 8418 101, fax: +48 61 8470 192
Sales: phone +48 61 8418 133, 136, 138, 148
Export: phone +48 61 8418 139

Branch department in Kraków
ul. Zygmunta Starego 130, 30-198 Kraków
phone no. +48 12 637 42 22 internal no 28



SWITCHGEAR



SURGE
ARRESTERS



MINING
EQUIPMENT



AUTOMATION



IT SYSTEMS



GRID CONTROL
AND SUPERVISION



ELECTRICITY
METERING



WATER
METERING



HEAT
METERING



GAS
METERING



SENSORS



METERING
SOLUTIONS