



# JS Master C+ IP68/IP65

DN25, DN32 & DN40 single-jet vane-wheel water meter

# JS Master C+ IP68/IP65

JS Master C+ IP68/IP65 is a single-jet vane-wheel dry water meter for precise measurement of water supply consumption. The advanced design engineering ensures a high dynamic response to metering conditions and a high immunity to strong magnetic fields. The water meter is compatible with optical and induction data communication modules from Apator Powogaz S.A. for automatic wired or wireless meter reading. The water meter is designed and manufactured to the MID (Measuring Instruments Directive) and complies with EN14154, OIML R49 and ISO4064 for the maximum measurement range of R160.

## Application

Cold water supply systems (max. 50°C) in multifamily housing, industrial facilities, public facilities, and metering stations. The maximum operating pressure (MOP) is 16 bar. The water meter is designed for installation in a horizontal orientation with the counter upward (H↑) or sideways (H→), and in a vertical orientation (V). The rotary counter provides easily readable indications directly from the front face and works well in different installation orientations. The standard IP68 version is compatible with directly installed induction data communication modules which feature #UTIP (Universal TI Plug), whereas the IP65 water meters support optical and induction data communication modules mounted using an interface ring.

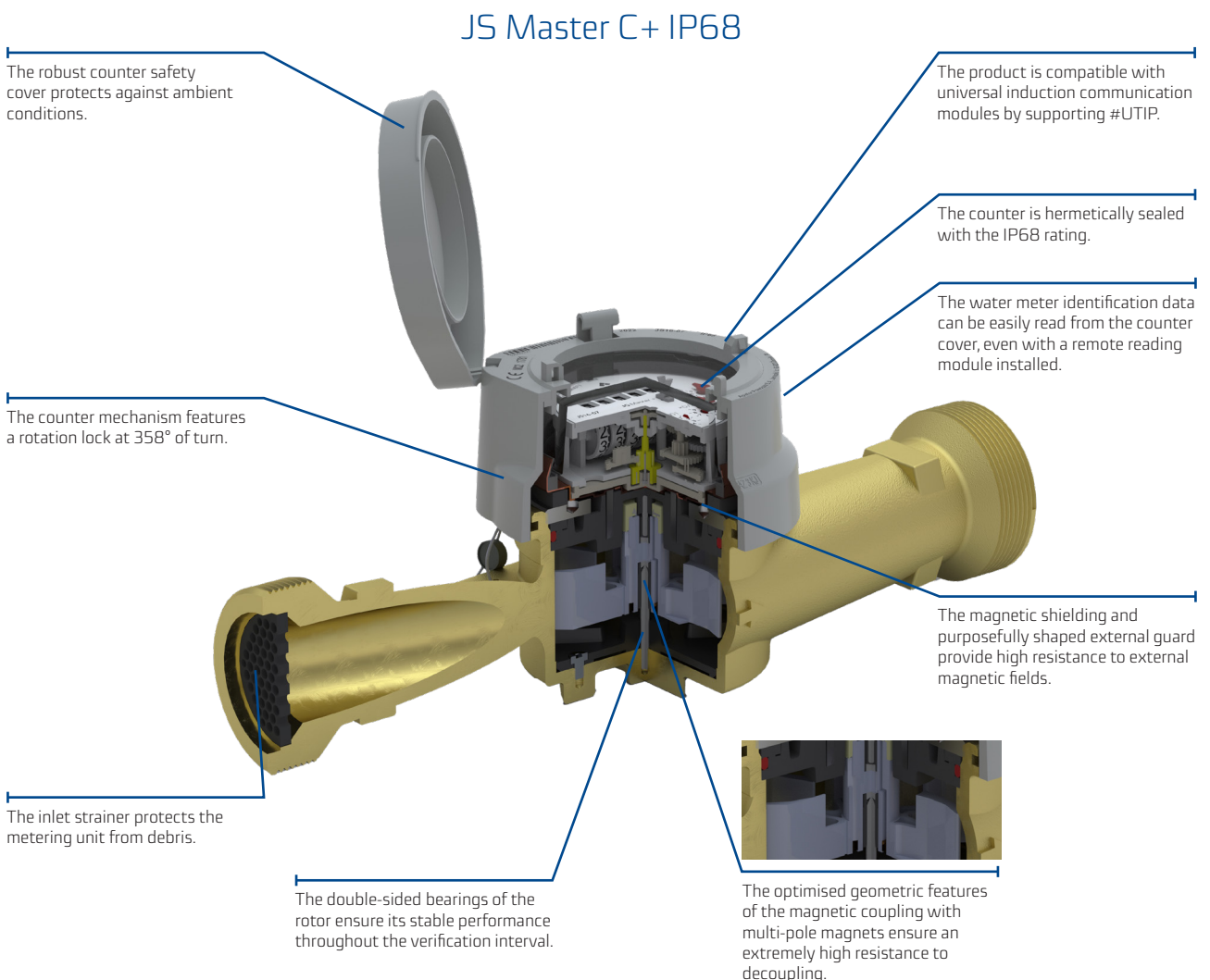

## JS Master C+ IP65

The robust counter safety cover protects against ambient conditions.

Compatible with optical and induction data communication modules.

The counter is hermetically sealed with the IP65 rating.

The water meter identification data can be easily read from the counter cover, even with a remote reading module installed.

The counter mechanism features a rotation lock at 358° of turn.

The magnetic shielding and purposefully shaped external guard provide high resistance to external magnetic fields.

The inlet strainer protects the metering unit from debris.

The double-sided bearings of the rotor ensure its stable performance throughout the verification interval.

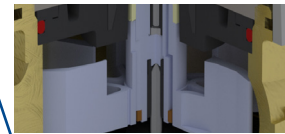

The optimised geometric features of the magnetic coupling with multi-pole magnets ensure an extremely high resistance to decoupling.

## Advantages

### Economy:

- Precise measurements at R160 – H
- Remote meter reading via wired or wireless interfaces
- Protection against:
  - strong magnetic field effects (by magnetic shielding)
  - mechanical tampering (a robust, tamper-proof counter design)
  - multiple rotations of the counter by more than 358°

## Convenient use:

- The water meter is AMR (automatic meter reading) (MDMS)-capable and provided with #UTIP in the IP68 version for direct installation of induction data communication modules, while the IP65 version is compatible with optical and induction data communication modules which feature an interface ring
- Easily readable:
  - the counter can be oriented anywhere within 0 to 358°
  - hermetically sealed, non-fogging IP68 counter: the counter mechanism is sealed in a copper-glass enclosure with a copper guard
- Wireless reading-capable via:
  - Induction communication modules: IN-WMBUS, IN-GSM for the IP65 and IP68 versions
  - APT-O3A-3 optical communication module for the IP65 version
- Wired reading-capable via:
  - Induction communication modules: IN-PULSE for the IP65 and IP68 versions
  - Optical communication modules: APT-MBUS-NA-2 and AT-MBUS-NE-03 for the IP65 version
  - NK reed relay pulse transmitter for the IP65 version

## Reliability:

- Tested and robust design
- Long operating life thanks to advanced materials:
  - with high resistance to wearing (in the bearings and pivots)
  - with a surface texture which minimises flow resistance (on the rotor and sealing disc)
- The inlet strainer (which protects the metering unit from debris)
- The counter mechanism is protected against mechanical damage

## Key features

- Output of event alarms: when equipped with an RF communication module, the water meter can indicate removal or breaking off of the module, module operating disturbance, reverse flow, leaks, etc.
- The rotor bearings, other solutions and materials used ensure stable metrology over the service life
- IP68 rating: the water meter is capable of operation in extremely difficult ambient conditions (even when fully immersed in water), including with a data communication module installed
- Stable flow rate inlet bore design
- Available in the IP65 version with a reed relay pulse transmitter

## New design of the cover and the face, exemplified by the IP65 counter

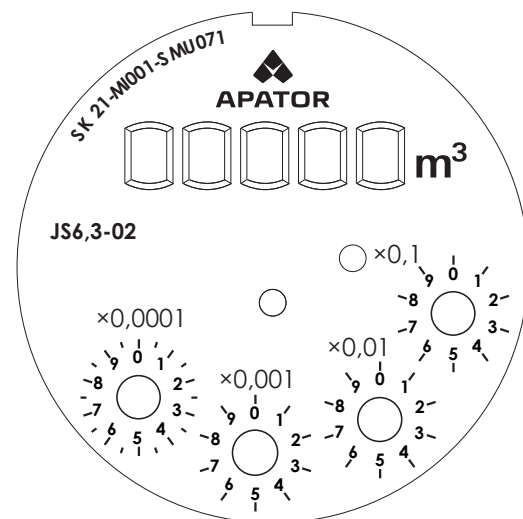

## Regulatory and standards compliance

- Directive 2014/32/EC of the European Parliament and of the Council of 26 February 2014 on the harmonisation of the laws of the Member States relating to the making available on the market of measuring instruments
- OIML R 49-1:2006 – Water meters intended for the metering of cold potable water and hot water. Part 1: Metrological and technical requirements
- OIML R 49-2:2013 – Water meters intended for the metering of cold potable water and hot water. Part 2: Test methods
- OIML R 49-3:2013 – Water meters intended for the metering of cold potable water and hot water. Part 3: Test report format
- EN 14154-1:2005+A2:2011 – Water meters. Part 1: General requirements
- EN 14154-2:2005+A2:2011 – Water meters. Part 2: Installation and conditions of use
- EN 14154-3:2005+A2:2011 – Water meters. Part 3: Test methods and equipment
- EN ISO 4064-1:2017 – Water meters for cold potable water and hot water. Part 1: Metrological and technical requirements
- EN ISO 4064-2:2017 – Water meters for cold potable water and hot water. Part 2: Test methods
- EN ISO 4064-5:2017 – Water meters for cold potable water and hot water. Part 5: Installation requirements
- EC type examination certificate no. SK 21-MI001-SMUU071
- Classification of environmental climate and mechanical conditions: Class B (ref. PN-ISO 4064-1:2014 (E))
- Classification of mechanical environment conditions: Class M1 (ref. Polish Regulation Dz.U. 2007.3.27)
- Classification of electromagnetic environment conditions: Class E1 (ref. Polish Regulation Dz.U. 2007.3.27)

All materials of the JS Master C+ IP68/IP65 water meters have PZH-NIH Hygiene Certificates for use with potable water.

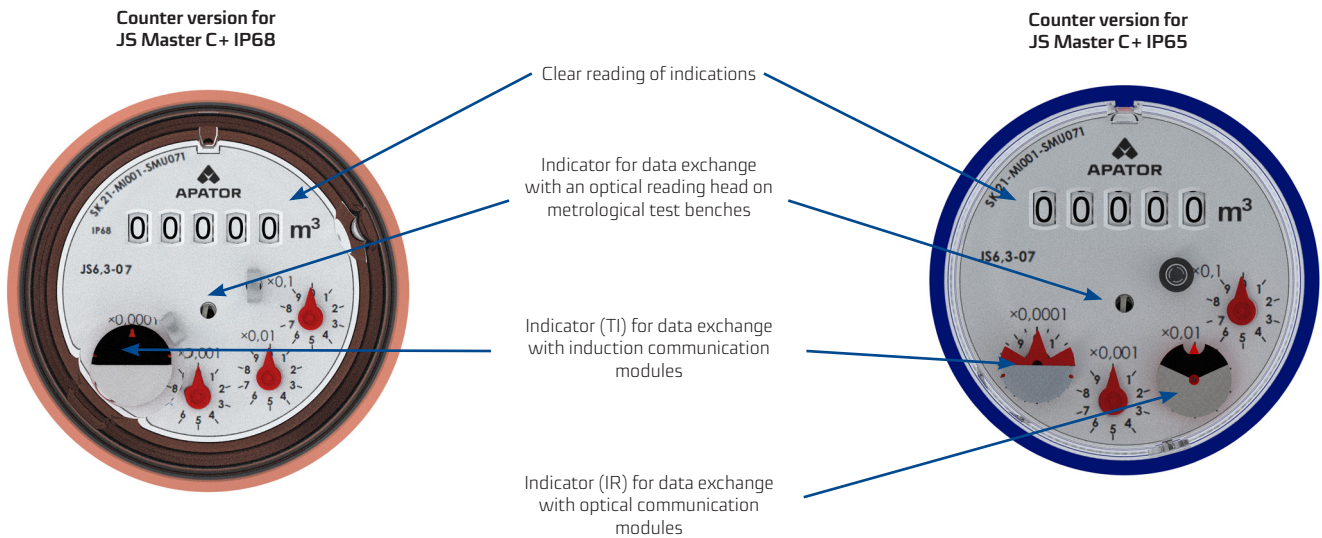

Table 1. Technical data

Parameter			JS Master C+ IP68/IP65			
			JS6,3-02* JS6,3-07** JS6,3-XX***	JS10-G1¼-02* JS10-G1¼-07** JS10-G1¼-XX***	JS10-02* JS10-07** JS10-XX***	JS16-02* JS16-07** JS16-XX***
Nominal diameter	DN	mm	25	25	32	40
Permanent flow rate	Q <sub>3</sub>	m <sup>3</sup> /h	6,3	10		16
Maximum flow rate	Q <sub>4</sub>	m <sup>3</sup> /h	7,875	12,5		20
Transitional flow rate	cold water	H↑R160 V,H→R63	Q <sub>2</sub>	dm <sup>3</sup> /h	63	
					160	
Minimum flow rate	cold water	H↑R160 V,H→R63	Q <sub>1</sub>	dm <sup>3</sup> /h	40	
					100	
Starting flow	–	dm <sup>3</sup> /h	13	21		31
Q <sub>2</sub> /Q <sub>1</sub> ratio	–	–	1.6			
Temperature class (rated operating temperature)	–	–	T30 / T50			
Flow profile sensitivity class	–	–	U0, D0			
Indicating range	–	m <sup>3</sup>	99,999			
Reading resolution	–	m <sup>3</sup>	0.00005			
Maximum pressure	P <sub>max</sub>	MPa	1.6			
Maximum pressure loss	Δp	kPa	63			
Maximum permissible error range: Q <sub>2</sub> ≤ Q ≤ Q <sub>4</sub>	ε	%	±2 for 0.1 to 30°C cold water ±3 for > 30°C water			
Maximum permissible error range: Q <sub>1</sub> ≤ Q < Q <sub>2</sub>	ε	%	±5			
NK reed relay pulse transmitter	–	dm <sup>3</sup> /pulse	10 (standard pulse rate); 100			100 (standard pulse rate); 10
Inlet and outlet pipe end threads	G	Inch	G1¼	G1¼	G1½	G2
	h	mm	36			
	H	mm	115			
	H1	mm	123			
Height	H2	mm	200			
	L	mm	260	260		300
Length	I	mm	380			440
	Weight (w/o connection fittings)	W/o NK transmitter	–	kg	2.0	2.2
With NK transmitter		–	kg	2.2	2.4	2.7

Versions:

\* Version **-02** – IP65-rated counter mechanism; supports readout with induction communication modules (Ti) and optical communication modules (IR)

\*\* Version **-07** – IP68-rated counter mechanism sealed with mineral glass enclosure with a copper guard; supports readout with induction communication modules (Ti)

\*\*\* Version **XX-NK** or **NKP** reed relay transmitter; supports reed relay pulse transmitters

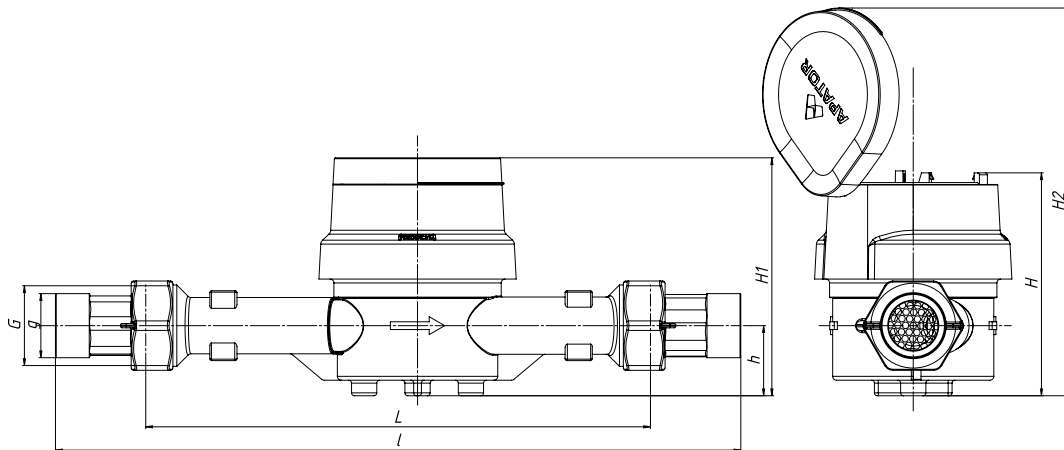

### Connection fittings

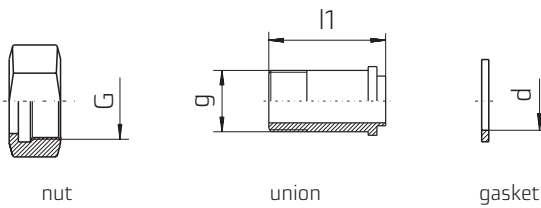

DN	G	g	d	l1
25	1¼"	1"	29	46.5
32	1½"	1¼"	36	56
40	2"	1½"	43	66

Example of the Master C+ IP68 water meters with compatible data communication modules:

### IN-GSM clip-on module, #UTIP (Universal TI Plug)

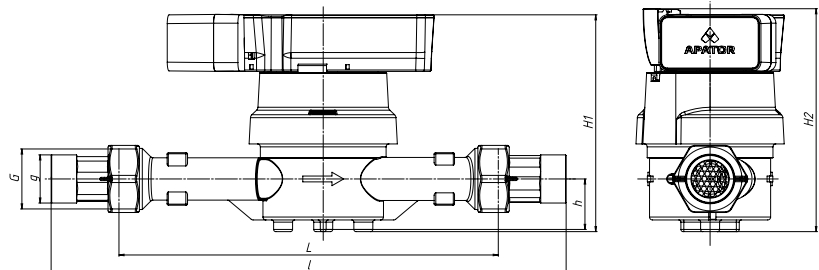
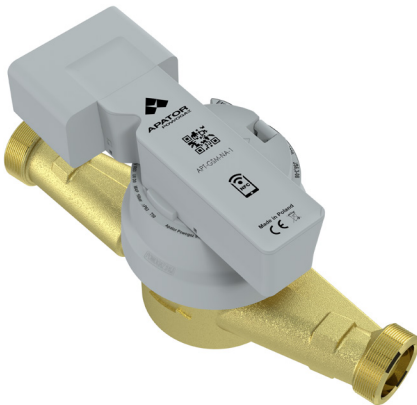

DN	25	32	40
H1	mm	149	
H2	mm	153	

### IN-WMBUS clip-on module, #UTIP (Universal TI Plug)

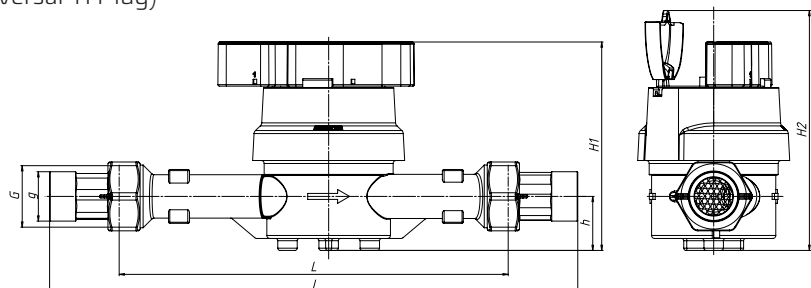

DN	25	32	40
H1	mm	140	
H2	mm	160.5	

Example of the Master C+ IP65 water meters with compatible data communication modules:

**IN-GSM clip-on module with the interface ring**

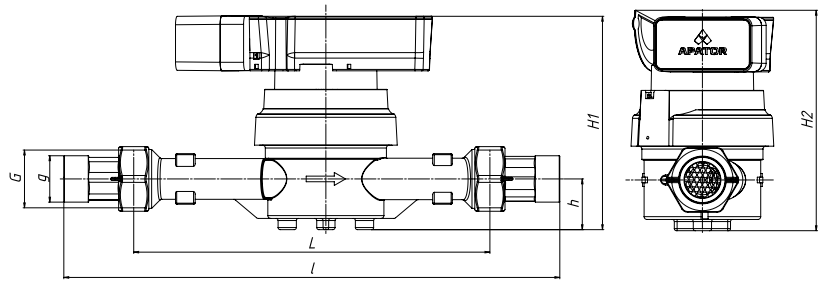

DN		25	32	40
H1	mm		151.85	
H2	mm		156.84	

**IN-WMBUS & IN-PULSE clip-on modules with the interface ring**

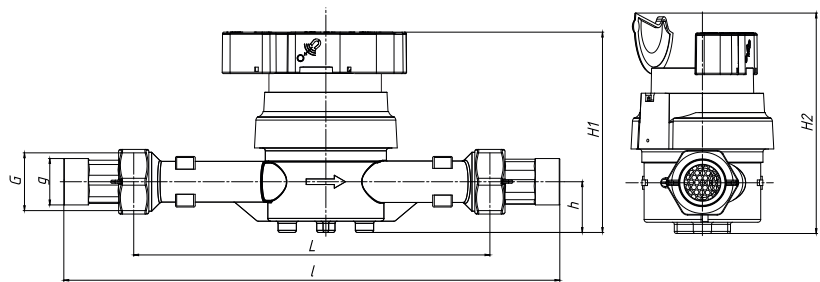

DN		25	32	40
H1	mm		142.55	
H2	mm		156.84	

**Water meter with the reed relay transmitter (NK) installed**

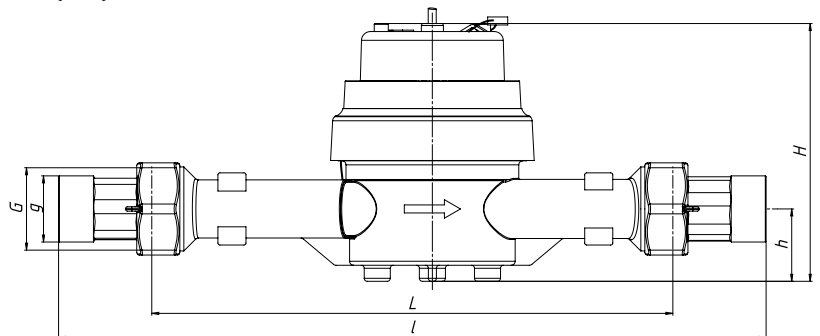

DN		25	32	40
h	mm		36.1	
H	mm		128.6	

### Pressure loss chart

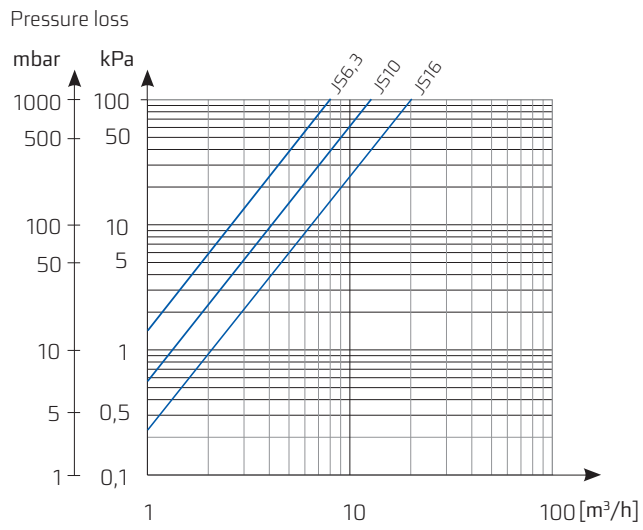

### Typical error chart

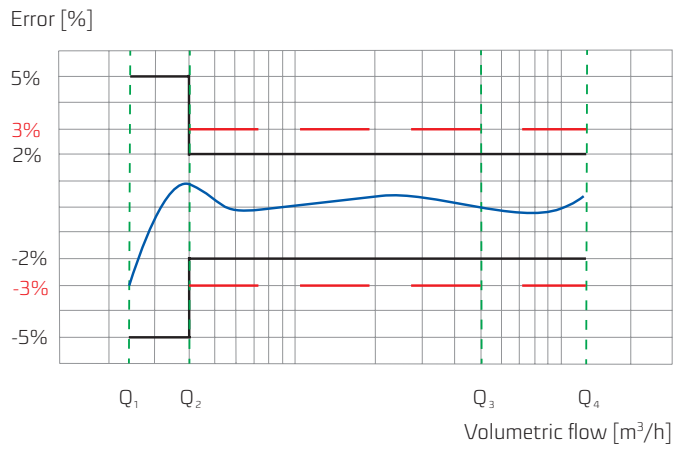

The data presented in the datasheet was correct on the date of publication.  
The manufacturer reserves the right to modify and improve its products without notice.  
This publication is indicative only and should not be construed as a commercial offer under the Polish Civil Code.



**Apator Powogaz S.A.**

Jaryszki 1c, 62-023 Żerniki

**Office:** sekretariat.powogaz@apator.com, tel. +48 61 84 18 101

**Sales/Customer Service:** tel. +48 61 84 18 149

**Customer Service Centre Support:** handel.powogaz@apator.com

**Exports:** export.powogaz@apator.com

**Technical Support:** support.powogaz@apator.com, tel. +48 61 8418 131, 134, 294

**Warranty Claims:** reklamacje.powogaz@apator.com