

NAXOM OP-04-1a

NAXOM OP-04-1b

NAXOM OP-04-2

Wireless M-Bus OMS compatible optical communication modules

The NAXOM: **OP-04-1a**, **OP-04-1b** and **OP-04-2** radio frequency modules are intended for reading and wireless output transmission of the metering data from Apator Powogaz S.A. water meters over the Wireless M-Bus communication protocol. The modules are compatible with OMS equipment. These modules also feature a uniquely extensive local and remote configuration of the operating parameters. The communication module scans the indicator of the connected water meter's counter by detecting the direction of the indicator revolutions. This detection enables remote transmission of the actual indications of the water meter counter. The specified battery life is 12 years maximum, with the standard transmission configuration for a predefined data transmission schedule and environmental conditions (class T50).

Application

The OP-04-1a communication module is intended only for installation on the JS/JS90 1.6÷2.5 Smart series and the OP-04-1b overlay on all JS/JS90 1.6÷4 Smart series single-jet water meters from Apator Powogaz. The module is available in two design versions: model "a" with a ½ AA battery and model "b" with a ⅔ AA battery. The above models fully replace the existing AT-WMBUS-16-2 in terms of functionality. The OP-04-2-communication module is intended for installation on SV-RTK volumetric water meters and available as a model with an AA battery. The communication modules can operate a wide range of equipment, creating a structure for remote reading and data transmission.



OP-04-1a



OP-04-1b



OP-04-2

Module type	Water meter type		
NAXOM OP-04-1a	JS 1,6-02 Smart+ JS 1,6-03 Smart+ JS 2,5-02 Smart+ JS 2,5-03 Smart+ JS 2,5-G1-02 Smart+ JS90 1,6-02 Smart+ JS90 1,6-03 Smart+ JS90 2,5-02 Smart+ JS90 2,5-03 Smart+ JS90 2,5-G1-02 Smart+	JS 1,6-02 Smart C+ JS 1,6-03 Smart C+ JS 2,5-02 Smart C+ JS 2,5-03 Smart C+ JS 2,5-G1-02 Smart C+	JS 1,6-05 Smart D+ JS 2,5-05 Smart D+ JS 2,5-G1-05 Smart D+ JS90 1,6-05 Smart D+ JS90 2,5-05 Smart D+ JS90 2,5-G1-05 Smart D+ JS 1,6-07 Smart D+ JS 2,5-07 Smart D+ JS 2,5-G1-07 Smart D+ JS90 1,6-07 Smart D+ JS90 2,5-07 Smart D+ JS90 2,5-G1-07 Smart D+
NAXOM OP-04-1b	JS 1,6-02 Smart+ JS 1,6-03 Smart+ JS 2,5-02 Smart+ JS 2,5-03 Smart+ JS 2,5-G1-02 Smart+ JS 4-02 Smart+ JS90 1,6-02 Smart+ JS90 1,6-03 Smart+ JS90 2,5-02 Smart+ JS90 2,5-03 Smart+ JS90 2,5-G1-02 Smart+ JS90 4-02 Smart+	JS 1,6-02 Smart C+ JS 1,6-03 Smart C+ JS 2,5-02 Smart C+ JS 2,5-03 Smart C+ JS 2,5-G1-02 Smart C+ JS 4-02 Smart C+	JS 1,6-05 Smart D+ JS 2,5-05 Smart D+ JS 2,5-G1-05 Smart D+ JS 4-05 Smart D+ JS90 1,6-05 Smart D+ JS90 2,5-05 Smart D+ JS90 2,5-G1-05 Smart D+ JS90 4-05 Smart D+ JS 1,6-07 Smart D+ JS 2,5-07 Smart D+ JS 2,5-G1-07 Smart D+ JS 4-07 Smart D+ JS90 1,6-07 Smart D+ JS90 2,5-07 Smart D+ JS90 2,5-G1-07 Smart D+ JS90 4-07 Smart D+
NAXOM OP-04-2	SV-RTK 2,5; SV-RTK 4,0; SV-RTK 16		

Key features

- Compatible with a wide range of single-jet water meters and select volumetric water meters from Apator Powogaz S.A.
- Easy and tamper-free installation on the water meter, even if it has already been deployed for operation
- Quick configuration with mobile equipment
- Real time clock with winter/summer time and leap year features
- Water meter type selection and configurable water meter-related properties
- Five operating modes to enable adjustment of the data transmission interval to the user's individual requirements
- Detection, logging and indication of water usage measurement abnormalities and module performance abnormalities by indication of all events
- Storing and reading the measured volume data from 1 to 16 months
- Supports custom configuration of the data transmission interval
- Water consumption readout with mobile terminals in the readout collector system or using a telemetry network in a stationary system
- Measurement data readouts from water meters are fully immune to all interference from external magnetic fields
- Wireless data transmission driven by the Wireless M-Bus communication protocol
- Compatible with AMR and data transmission structure equipment in compliance with Open Metering System Vol. 3 or Vol. 4
- Data transmission encryption with 128-bit AES-CBC mode 5 for OMS3 or mode 5 or 7 for OMS4.
- Operates on the 868 MHz unlicensed ISM band

Data reading and writing

It enables reading and writing the following data over RF communication:

- water meter number,
- current date,
- operating days,
- operation/transmission times,
- transmission frame contents configuration,
- day of recording the monthly volume,
- current volume,
- volume history,
- current flow rate,
- event details and threshold values,
- event auto-delete configuration.

Event information and historical volume values can be deleted; the communication module can be switched over to the storage mode (all possible events are defined at the events point).

Transmission encryption (AES key)

To ensure confidentiality of the metering data, the RF-transmitted consumption data is protected with the AES-128 + CBC encryption algorithm (which guarantees variance of the transmitted data when there are no changes in the measured volume). The received data can be decrypted if the encryption key is known. The key is 32 alphanumeric characters. The encryption key is also required for reading and writing of the configuration data. A new encryption key can be set up if the current key of the communication module is known.

Volume history

The communication module collects and saves historical volume data for the last 16 months. The volume written day can be configured (day 1 to 28, or the last day of the month). The data frame may contain the historical data from 1 to 16 months back. The service mode allows accessing the whole historical content (irrespective of the months configured to be transmitted in an RF frame).

Events

The communication module can detect, log and show water usage measurement abnormalities and module performance abnormalities by the indication of events. In the communication module's configuration, the custom events are selected where the details should be output in a spontaneous data frame whenever such an event occurs. The events are appended periodically to the data frames. Each next data frame holds the details of the successive, logged event.

The following events have been defined:

Custom events that are relevant to the customer and concern the flow, battery status or operating conditions:

- magnetic field: an external magnetic field was detected,
- disconnected: the communication module has been separated from its water meter,
- zero Flow thresholds: maximum daily volume, maximum total volume over a preset number of days, number of days): a zero flow condition is detected when the total volume over a preset number of days is below the threshold, or when the maximum daily volume is not exceeded on any of the preset days,
- minimum flow rate (thresholds: flow rate, minimum volume): this event is detected when the device records the minimum volume (or a higher volume) at a flow that is below the threshold,
- maximum flow rate (thresholds: flow rate, successive instances of flow over the threshold): this event is detected when a flow above the threshold is recorded over the successive 10-second periods, and the number of those instances is at least the one defined for the threshold,
- reverse flow (threshold: reverse flow volume): this is a reverse flow with a volume that exceeds the threshold.
- water leak (thresholds: water meter start flow, leak time (multiple of 10 minutes)): this event occurs when a continuous flow is detected with a value above the threshold for a preset duration

- battery operating time exceeded (threshold: min. count of operating days): this event occurs when the number of the communication module operating days exceeds the threshold,
- access error (threshold: number of failed attempts to communicate with the module): this event occurs when the number of failed communication attempts exceeds the defined threshold.

Service events that are relevant to the manufacturer. The event emergence and specifics are available to the manufacturer only and not displayed in meter readout apps.

Regulatory and standard compliance

- Compliant with Directive 2014/53/EU of the European Parliament and of the Council of 16 April 2014 on the harmonisation of the laws of the Member States relating to the making available on the market of radio equipment and repealing Directive 1999/5/EC
- Compliant with Directive 2011/65/EU of the European Parliament and of the Council of 8 June 2011 on the restriction of the use of certain hazardous substances in electrical and electronic equipment
- PN-EN 13757-4. Communication systems for meters. Part 4 – Wireless M-Bus communication
- PN-EN 13757-3. Communication systems for meters. Part 3: Application protocols
- ETSI EN 301 489-1 V1.9.2. Electromagnetic compatibility and Radio spectrum Matters (ERM); Electromagnetic Compatibility (EMC) standard for radio equipment and services. Part 1: Common technical requirements
- ETSI EN 300 220-1 V3.1.1. Short Range Devices (SRD) operating in the frequency range 25 MHz to 1,000 MHz Part 1: Technical characteristics and methods of measurement

Specifications

Module	NAXOM OP-04-1a	NAXOM OP-04-1b	NAXOM OP-04-2
Cooperation with water meters	only with water meters: JS/J590 1.6÷2.5 Smart series	all types of water meters: JS/J590 1.6÷4 Smart series	SV-RTK 2,5; SV-RTK 4,0; SV-RTK 16
Communication standard	OMS3 no security, OMS3 security mode 5, OMS4 security mode 5, OMS4 security mode 7		
Power supply	3 V battery, size ½ AA	3 V battery, size ⅔ AA	3 V, battery, size AA
Operating temperature	0°C to 55°C		
Signal output	Internal antenna		
Transmission frequency	868 MHz		
Communication protocol	Wireless M-Bus		
Consumption detection	optical		
Power output	10 mW / 50 Ω		
Power output level stability	+1 dB / -3 dB		
Sensitivity	-108 dBm		
Operating time	12 years max.*		
Outdoor range	350 m		
Ingress protection rating	IP65		
Installation method	Directly on the water meter		
Weight	36 g	43 g	53 g

***configuration-dependent:**

Configuration example: spontaneous data frame standard transmission interval: 70 seconds for 12 hours a day, 5 days a week; 768 seconds at all other hours. Transmission data frame contents: clock time, volume, event flags, water meter number, last 12 months of history, event details. The battery operating life may vary with the actual configuration settings. Contact the manufacturer for detailed information about the specific configuration.

temperature-dependent:

Module operation in the following temperature ranges: 80% of operating time at 30°C maximum; 10% of operating time at 30–40°C; 10% of operating time at 55°C maximum.

The applied temperature profile matches the average temperature profile for the housing sector.

Dimensions

Parameter	Unit	OP-04-1a	OP-04-1b	OP-04-2
h	mm	16.5	16.5	26.1
H	mm	86.6	95.5	140.6
H ₂	mm	67.6	67.6	66.0
H ₃	mm	26.4	34.9	44.1
L	mm	110 (G¾"); 130 (G1")	110 (G¾"); 130 (G1")	110 (G¾"); 130 (G1")

OP-04-1a (1/2 AA battery)

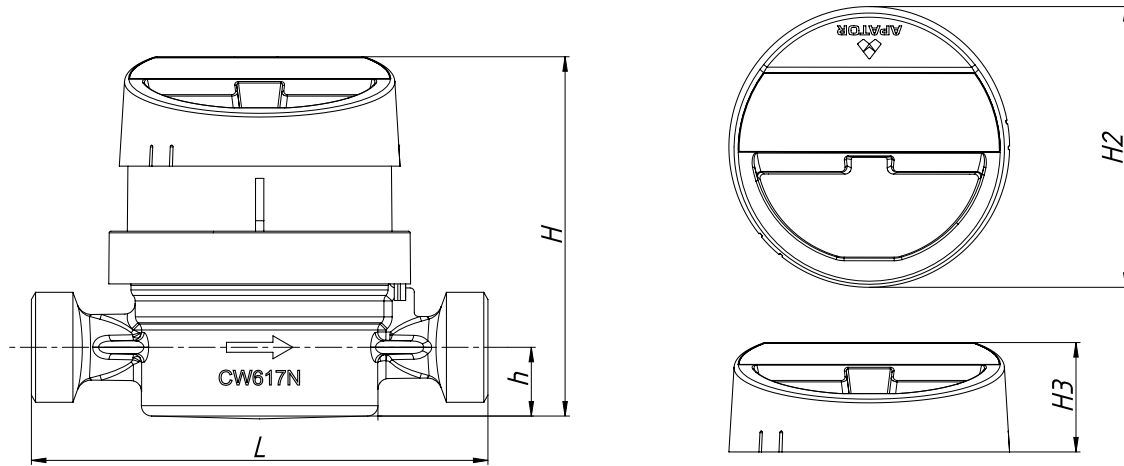

OP-04-1b (2/3 AA battery)

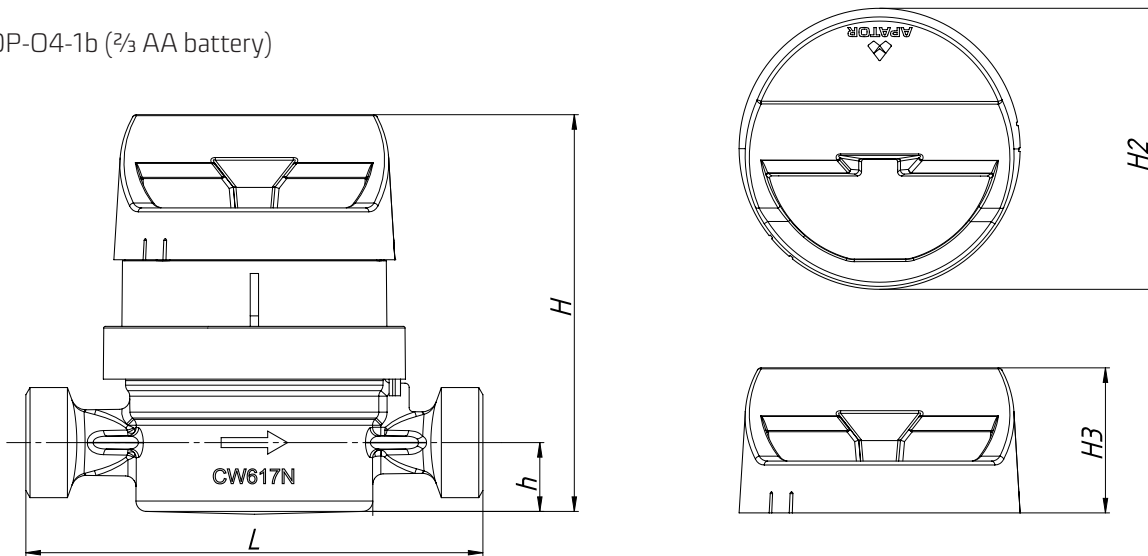

OP-04-2 (AA battery)

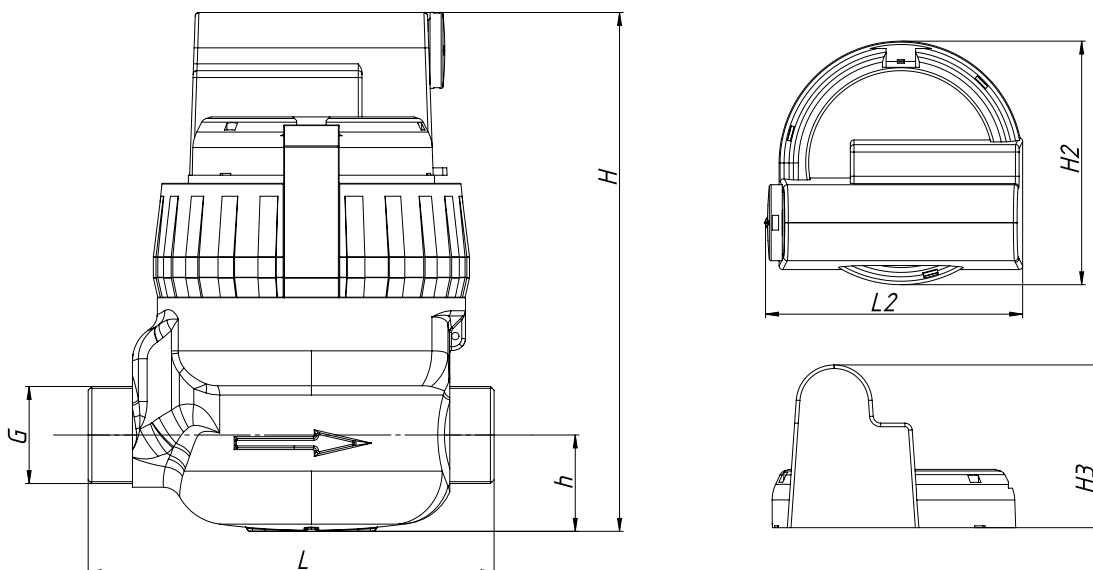

The data here is current on the date of issue.

The manufacturer has the right to modify and improve the products without prior notice.

This publication is intended for information purposes only and shall not be construed as a commercial offer under the Polish Civil Code.



Apator Powogaz S.A.

Jaryszki 1c, 62-023 Żerniki, Poland

Office: sekretariat.powogaz@apator.com, tel. +48 61 84 18 101

Sales / Customer Service: tel.: +48 61 84 18 149

Customer Service Centre Support: handel.powogaz@apator.com

Exports: export.powogaz@apator.com

Technical Support: support.powogaz@apator.com, tel. +48 61 8418 131, 134, 294

Warranty Claims: reklamacje.powogaz@apator.com