

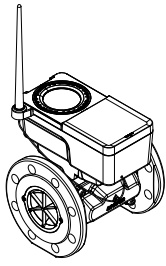

WATER METER TYPES



Ultrasonic water meters with a cast iron body and built-in radio
Ultrimis PRO ULP DN80-100

CE, MID, IP68, WM-Bus, LoRaWAN

ACCESSORIES

Smartphone



Android, NFC

TestBox



Smartphone app

SPIDAP

Android, NFC



SHIPPING AND STORAGE

Protect against shocks and vibration

Store between 10°C and 25°C

SAFE OPERATING CONDITIONS

Do not touch damaged equipment	Do not touch damaged equipment	Risk of crushing	Do not apply extra load to equipment	Install/remove equipment only with shut-off valves closed
Risk of injury during installation, removal, or handling of the equipment	Possible leakage of cold or hot water under high pressure	Do not dispose of equipment with household waste	Prevent access to the equipment by unauthorized persons (including unsupervised children), or persons with reduced mental or physical abilities	Risk of electrolyte leakage
Risk of battery ignition	Do not operate equipment in extreme weather conditions	Do not remove, charge, recharge by other means, disassemble, throw into fire, or short-circuit the battery	Placing the water meter on its flanges may result in it tipping over and causing permanent damage to components, including plastic parts and the antenna connector.	

BASIC INFORMATION

- Max water temperature **50°C**
- Ambient temperature **-10 - 60°C**
- Operating pressure **16 bar**
- Battery life **up to 16 years***
One built-in 3 V DC lithium battery
Lithium content – approx. 3,5 g
- RF connectivity parameters: EU868 MHz do **25 mW** E.R.P.**
- Communication standard: WM-Bus, OMS-compliant
LoRaWAN V1.0.4-compliant
- Communication standard: WM-Bus – radio frame sent at 16-second intervals
LoRaWAN – radio frame sent at 7-hour intervals

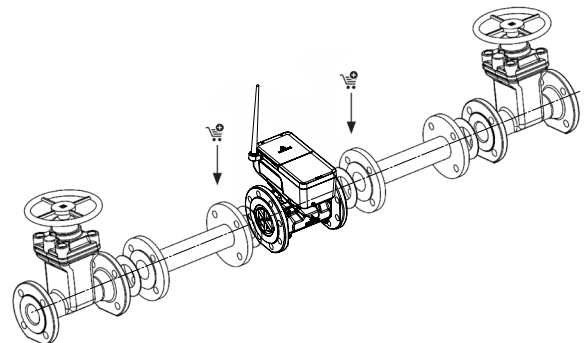

* Depending on the configuration and ambient conditions.

** Applies to the set with the supplied antenna installed in the reference position (antenna mounted magnetically to the device housing).

PRODUCT FEATURES

Exit from shipping mode

- Via NFC
- Minimum flow rate:
 - equivalent flow Q_2 , according to the device's R class, over 1 hour.

Installation of the antenna

Before starting operation, the antenna must be installed – a requirement for proper device operation.

Alarms

- Zero flow: alarm triggered after 30 seconds
- Leakage: flow $> 0,3 \times Q_2$ przez 720 min
- Water main leak (bypass flow): alarm trigger: flow $> Q_4$ for 30 s
- Low battery: lifespan > 1 year
- Tampering detected: enclosure tamper
- Back flow: alarm triggered after > 30 s of back flow time
- Temperature threshold exceeded:
 - T50: $< 2^\circ\text{C}$ or $> 50^\circ\text{C}$

ESSENTIAL INSTALLATION COMPONENTS

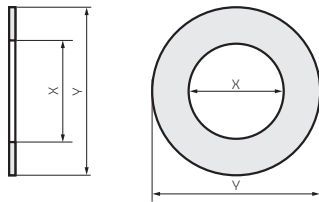

DN	X [cal]	Y [mm]
80	89	142
100	115	162

CLASSIFICATION OF ENVIRONMENTAL CONDITIONS

- Environmental classification – Climate and mechanical conditions: Class **B** (EN ISO 4064: 2014)
- Environmental classification – mechanical conditions: Class **M1** (Directive 2014/32/UE of 26 February 2014)
- Electromagnetic conditions: Class **E1 & E2** (EN ISO 4064: 2014 and Directive 2014/32/UE of 26 February 2014)

COMPATIBILITY AND INSTALLATION REQUIREMENTS

	Water meter installation positions			Flow profile accuracy class	
	Horizontal with the counter pointing upwards	Horizontal with the counter pointing sideways	Vertical with the counter pointing sideways	CE-compliant	Per manufacturer
Ultrimis PRO ULP	H↑	H→	V	U0 D0	U5 D2

* The tolerance of the flow axis position for all meters—horizontal, vertical, and inclined—is $\pm 5^\circ$ in accordance with the PN-EN ISO 4064-2 standard.

** If there is any fitting other than standard connectors before or after the water meter (which may disturb the flow), it is recommended to extend the straight pipe sections: upstream of the meter to $U3 = 3 \times \text{DN}$, and downstream to $D2 = 2 \times \text{DN}$. In the case of fittings that strongly disturb the flow profile, these values can be increased two- to threefold.

CONNECTION EXAMPLE DIAGRAM

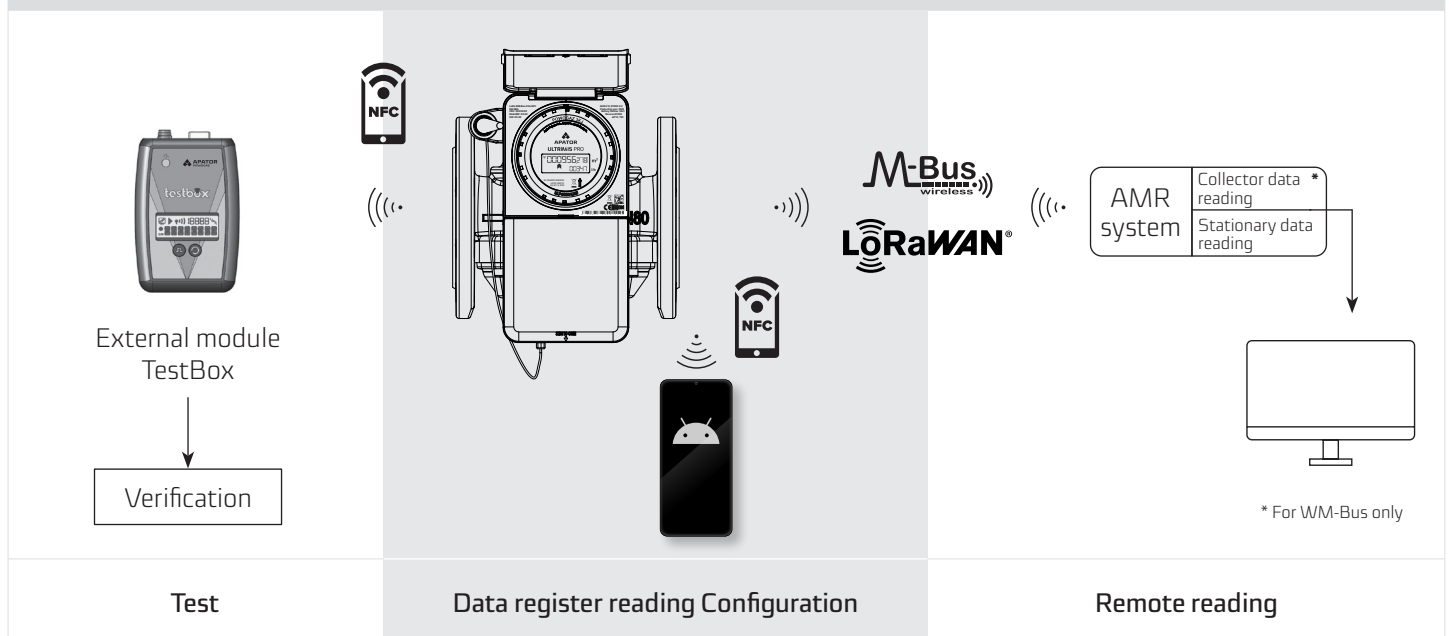



INSTALLATION AND OPERATING RECOMMENDATIONS



This product should be installed by a professional licensed for servicing and operation of water and sewage systems.



Close the upstream and downstream valves before installing/removing the product.

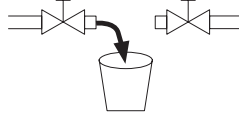

When installing or removing the water meter, place a container to collect the liquid, clean the threaded ends, and flush the system section the water meter will be installed in.

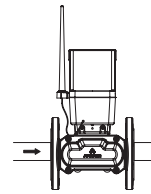

Mind the indicated direction of water flow.

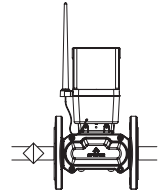

Install a separating filter upstream of the water meter.

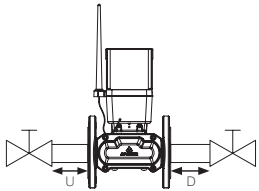

Keep the straight line sections upstream and downstream of the water meter as shown in the table below

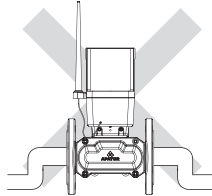

Protect from air pockets; do not install in the highest points of the system.

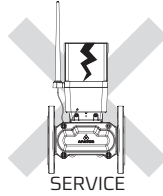

Have the water meter serviced if defective.

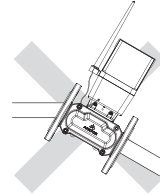

Prevent stresses from misalignment with the pipeline.

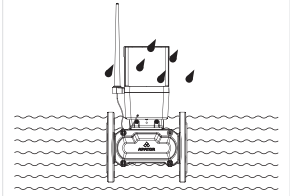

This device is suitable for operation in wet or flooding conditions per IP68

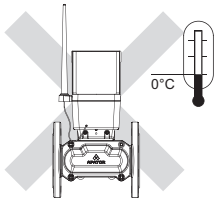

Protect from freezing

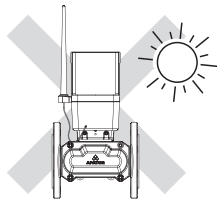

Protect from high temperature and UV light.

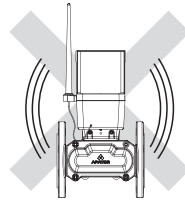

Protect from vibration.

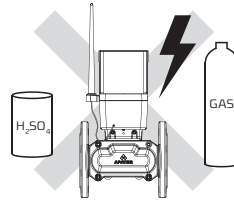

Do not use near sources of acids, gases and/or electrical systems.

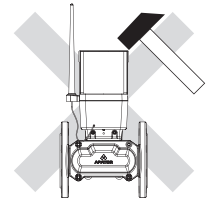

Protect from shocks.

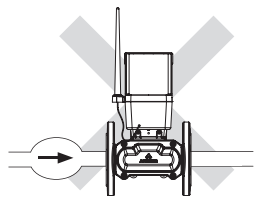

Protect from hydraulic shocks.

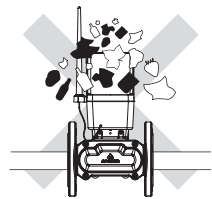

Keep the installation site clean.

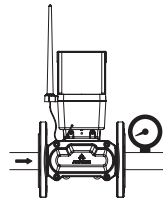

Minimum water meter downstream pressure $P_{min} \geq 0,3$ bar

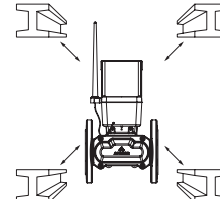

The water meter should be installed in such a way as to maintain the greatest possible distance from metal elements, especially in the area of the antenna.

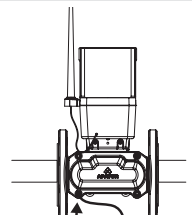

In environments with a high level of electromagnetic interference, the water meter must be grounded by connecting it to the grounding installation. After making the connection, the screw should be retightened to a torque of 10 Nm

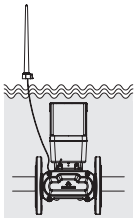

The antenna should be installed above the water level if the water meter is intended for continuous submersion



Do not dispose of the device with household waste. Bring the device to a selective waste collection point. Please recycle.

NOTE: See www.apator.com for detailed information about the operating principle and conditions

WARNINGS:

This manual is the property of Apator Powogaz S.A., and all rights to this document are reserved. Any copying or distribution of this manual is strictly prohibited. As this manual is part of the device, it should be kept with the device to ensure access to information for both the user and qualified service personnel. It is recommended to read this manual before first using the device to ensure safe and proper operation.

Apator Powogaz S.A. shall not be held liable for any personal injuries, indirect damages, or material losses resulting from improper installation or incorrect use of the device, inconsistent with its intended purpose.

PROHIBITED:

The device must be used in accordance with this manual, and any modifications, attempts at self-repair, or improper use of the device are prohibited. In case of malfunction or suspected issues with the device, contact qualified service personnel.

Apator Powogaz S.A. has the right to modify and improve the manufactured equipment without prior notice.



Apator Powogaz S.A.
Jaryski 1c, 62-023 Żerniki
www.apator.com

Office: sekretariat.powogaz@apator.com, tel. +48 61 84 18 101

Sales Department/Customer Service: tel. +48 61 84 18 149

Customer Service Center: handel.powogaz@apator.com

Export: export.powogaz@apator.com

Technical support: support.powogaz@apator.com, tel. +48 61 8418 131, 134, 294

Complaints: reklamacje.powogaz@apator.com